

# High Power Single Thyristor Module

$I_{TRMS} = 928 \text{ A}$   
 $I_{TAV} = 600 \text{ A}$   
 $V_{RRM} = 2000\text{-}2200 \text{ V}$

Preliminary data

$V_{RSM}$ $V_{DSM}$ V	$V_{RRM}$ $V_{DRM}$ V	Type
2100	2000	MCO 600-20io1
2300	2200	MCO 600-22io1

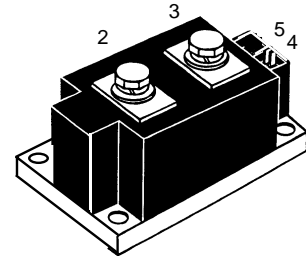
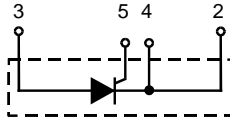

Symbol	Test Conditions	Maximum Ratings
$I_{TRMS}$	$T_{VJ} = T_{VJM}$	928 A
$I_{TAV}$	$T_C = 85^\circ\text{C}$ ; 180° sine	600 A
$I_{TSM}$	$T_{VJ} = 45^\circ\text{C}$ $V_R = 0$	t = 10 ms (50 Hz) 15000 A t = 8.3 ms (60 Hz) 16000 A
	$T_{VJ} = T_{VJM}$ $V_R = 0$	t = 10 ms (50 Hz) 13000 A t = 8.3 ms (60 Hz) 14400 A
$I^2t$	$T_{VJ} = 45^\circ\text{C}$ $V_R = 0$	t = 10 ms (50 Hz) 1125000 A <sup>2</sup> s t = 8.3 ms (60 Hz) 1062000 A <sup>2</sup> s
	$T_{VJ} = T_{VJM}$ $V_R = 0$	t = 10 ms (50 Hz) 845000 A <sup>2</sup> s t = 8.3 ms (60 Hz) 813000 A <sup>2</sup> s
$(di/dt)_{cr}$	$T_{VJ} = T_{VJM}$ repetitive, $I_T = 960 \text{ A}$ f = 50 Hz, $t_p = 200 \mu\text{s}$ $V_D = 2/3 V_{DRM}$	100 A/ $\mu\text{s}$
	$I_G = 1 \text{ A}$ , non repetitive, $I_T = I_{TAVM}$ $di_G/dt = 1 \text{ A}/\mu\text{s}$	500 A/ $\mu\text{s}$
$(dv/dt)_{cr}$	$T_{VJ} = T_{VJM}$ ; $V_{DR} = 2/3 V_{DRM}$ $R_{GK} = \infty$ ; method 1 (linear voltage rise)	1000 V/ $\mu\text{s}$
$P_{GM}$	$T_{VJ} = T_{VJM}$ $t_p = 30 \mu\text{s}$	120 W
	$I_T = I_{TAVM}$ $t_p = 500 \mu\text{s}$	60 W
$P_{GAV}$		30 W
$V_{RGM}$		10 V
$T_{VJ}$		-40...140 °C
$T_{VJM}$		140 °C
$T_{stg}$		-40...125 °C
$V_{ISOL}$	50/60 Hz, RMS t = 1 min	3000 V~
	$I_{ISOL} \leq 1 \text{ mA}$ t = 1 s	3600 V~
$M_d$	Mounting torque (M6)	4.5-7/40-62 Nm/lb.in.
	Terminal connection torque (M8)	11-13/97-115 Nm/lb.in.
Weight	Typical including screws	650 g

## Features

- Direct copper bonded Al<sub>2</sub>O<sub>3</sub> -ceramic with copper base plate
- Planar passivated chips
- Isolation voltage 3600 V~
- UL applied
- Keyed gate/cathode twin pins

## Applications

- Motor control, softstarter
- Power converter
- Heat and temperature control for industrial furnaces and chemical processes
- Lighting control
- Solid state switches

## Advantages

- Improved temperature and power cycling
- Reduced protection circuits

Data according to IEC 60747 and refer to a single thyristor/diode unless otherwise stated. IXYS reserves the right to change limits, test conditions and dimensions

Symbol	Test Conditions	Characteristic Values	
$I_{RRM}$	$T_{VJ} = T_{VJM}; V_R = V_{RRM}$	60	mA
$V_T$	$I_T = 600 \text{ A}; T_{VJ} = 25^\circ\text{C}$	1.15	V
$V_{TO}$	For power-loss calculations only ( $T_{VJ} = T_{VJM}$ )	0.77	V
$r_T$		0.42	m $\Omega$
$V_{GT}$	$V_D = 6 \text{ V}; T_{VJ} = 25^\circ\text{C}$	2	V
	$T_{VJ} = -40^\circ\text{C}$	3	V
$I_{GT}$	$V_D = 6 \text{ V}; T_{VJ} = 25^\circ\text{C}$	300	mA
	$T_{VJ} = -40^\circ\text{C}$	400	mA
$V_{GD}$	$T_{VJ} = T_{VJM}; V_D = 2/3 V_{DRM}$	0.25	V
$I_{GD}$	$T_{VJ} = T_{VJM}; V_D = 2/3 V_{DRM}$	10	mA
$I_L$	$T_{VJ} = 25^\circ\text{C}; V_D = 6 \text{ V}; t_p = 30 \mu\text{s}$ $di_G/dt = 1 \text{ A}/\mu\text{s}; I_G = 1 \text{ A}$	400	mA
$I_H$	$T_{VJ} = 25^\circ\text{C}; V_D = 6 \text{ V}; R_{GK} = \infty$	300	mA
$t_{gd}$	$T_{VJ} = 25^\circ\text{C}; V_D = 1/2 V_{DRM}$ $di_G/dt = 1 \text{ A}/\mu\text{s}; I_G = 1 \text{ A}$	2	$\mu\text{s}$
$t_q$	$T_{VJ} = T_{VJM}; V_R = 100 \text{ V}; V_D = 2/3 V_{DRM}; t_p = 200 \mu\text{s}$ $dv/dt = 50 \text{ V}/\mu\text{s}; I_T = 500 \text{ A}; -di/dt = 10 \text{ A}/\mu\text{s}$	typ. 350	$\mu\text{s}$
$R_{thJC}$	DC current	0.065	K/W
$R_{thJK}$	DC current	0.085	K/W
$d_S$	Creep distance on surface	12.7	mm
$d_A$	Strike distance in air	9.6	mm
$a$	Maximum allowable acceleration	50	m/s <sup>2</sup>

Optional accessories for modules

Keyed Gate/Cathode twin plugs with wire length = 350 mm, gate = yellow, cathode = red

Type **ZY 180 L** (L = Left for pin pair 4/5) { UL 758, style 1385, File E 38136,  
CSA class 5851, guide 460-1-1, appl. 41234

### Dimensions in mm (1 mm = 0.0394")

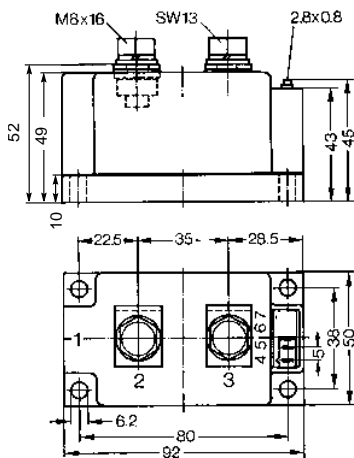

### Peak reverse recovery current versus -di/dt

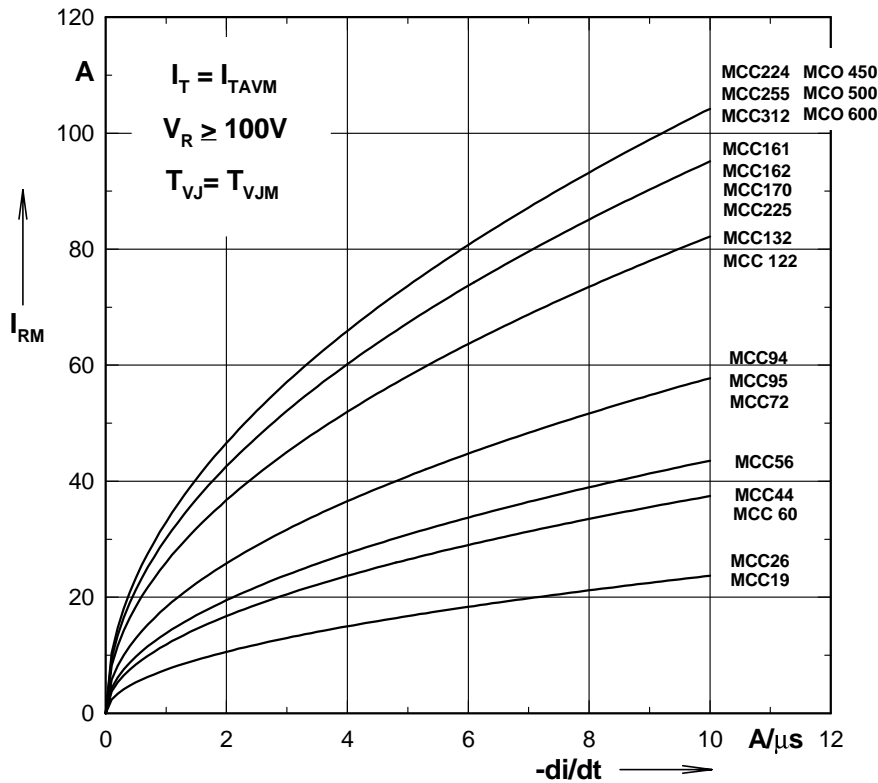

### Recommended RC snubber network against hole storage effect overvoltage

Type	Supply Voltage $V_{VRMS}$		
	$\leq 250 V$	$\leq 400 V$	$\leq 575 V$
MCC/MCD/MDD 19/26	R = 68 $\Omega$ /6 W C = 0.22 $\mu F$	R = 68 $\Omega$ /6 W C = 0.22 $\mu F$	R = 100 $\Omega$ /10 W C = 0.1 $\mu F$
MCC/MCD/MDD 44/56/60/72/94/95	R = 33 $\Omega$ /10 W C = 0.22 $\mu F$	R = 47 $\Omega$ /10 W C = 0.22 $\mu F$	R = 68 $\Omega$ /10 W C = 0.1 $\mu F$
MCC/MCD/MDD/MCO/MDO 122/132/142/161/162/170/ 172/220/225/250/255/310/ 312/450/500/600	R = 33 $\Omega$ /25 W C = 0.47 $\mu F$	R = 33 $\Omega$ /25 W C = 0.47 $\mu F$	R = 47 $\Omega$ /25 W C = 0.1 $\mu F$

#### Conditions

$f = 40 - 60 \text{ Hz}$   
 Short circuit voltage 4-6 %  
 Voltage safety factor 2.5

