

## 18V Multi-Topology LED Driver with Dimming Control

### General Description

The RT8498 is a current-mode LED driver supporting wide input voltage range from 3V to 18V and output voltage up to 18V. With internal 350kHz operating frequency, the size of the external PWM inductor and input/output capacitors can be minimized. High efficiency is achieved by a 100mV current sensing control. LED dimming control can be done from either analog or PWM signal. The RT8498 provides an internal soft-start function to avoid inrush current and thermal shutdown to prevent the device from overheat.

The RT8498 is available in the SOT-23-6 package.

### Ordering Information

RT8498□□

- Package Type  
E : SOT-23-6
- Lead Plating System  
G : Green (Halogen Free and Pb Free)

Note :

Richtek products are :

- ▶ RoHS compliant and compatible with the current requirements of IPC/JEDEC J-STD-020.
- ▶ Suitable for use in SnPb or Pb-free soldering processes

### Marking Information

47=DNN

47= : Product Code  
DNN : Date Code

### Features

- High Voltage : VIN Up to 18V, VOUT Up to 18V
- Built-In 2A Power Switch
- Current-Mode PWM Control
- 350kHz Fixed Switching Frequency
- Analog, PWM Digital or PWM Converting to Analog with One External Capacitor
- Internal Soft-Start to Avoid Inrush Current
- Under-Voltage Lockout
- Internal Over Voltage Protection to Limit Output Voltage
- Cycle-by Cycle Current Limit
- Thermal Shutdown

### Applications

- GPS, Portable DVD Backlight
- Display Cabinet Lamp and Room Lighting
- IP Camera

### Pin Configuration

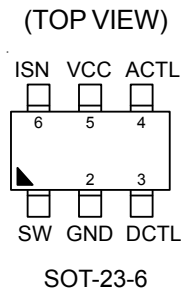

Functional Pin Description

Pin No.	Pin Name	Pin Function
1	SW	Switch node of the PWM converter.
2	GND	Ground.
3	DCTL	Digital dimming control input.
4	ACTL	Analog dimming control input. Effective programming range is 0.65V to 1.2V.
5	VCC	Supply voltage input. For good bypass, connect a low ESR capacitor between this pin and GND.
6	ISN	Current sense input. Voltage threshold between VCC and ISN is 100mV.

Functional Block Diagram

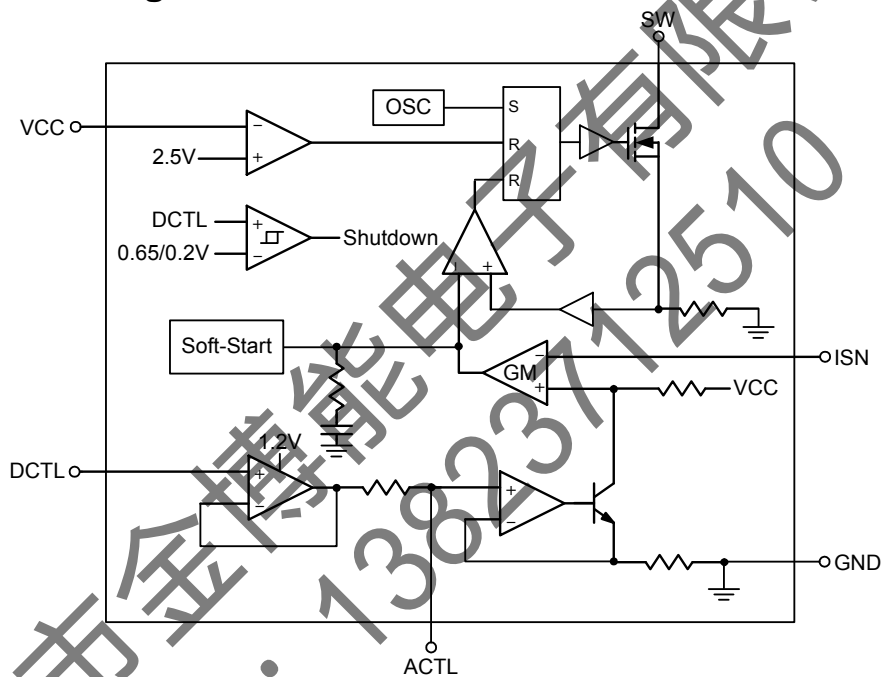

Operation

The RT8498 is specifically designed to be operated in Buck, Boost and Buck-Boost converter applications. This device uses a fixed frequency, current-mode control scheme to provide excellent line and load regulation. The maximum duty ratio of the RT8498 is 100% (typ.), and the minimum on time is 150ns (typ.)

The current through the sense resistor is set by the programmed voltage and the sense resistance. The voltage across the sense resistor can be programmed by the analog or digital signal at the ACTL pin. By adding a 0.47μF filtering capacitor on the ACTL pin, the PWM dimming

signal on DCTL pin will be averaged and converted into analog dimming signal on the ACTL pin.  $V_{ACTL} = 0.65V + 0.55 \times \text{PWM dimming duty ratio}$ . The RT8498 provides protection functions which include over-temperature, and switch current limit to prevent abnormal situations.

**Absolute Maximum Ratings** (Note 1)

- Supply Input Voltage, VCC ----- -0.3V to 21V
- SW Pin Voltage at Switching Off, ISN ----- -0.3V to 21V
- DCTL, ACTL Pin Voltage ----- -0.3V to 21V
- Power Dissipation, P<sub>D</sub> @ T<sub>A</sub> = 25°C
- SOT-23-6 ----- 0.48W
- Package Thermal Resistance (Note 2)
- SOT-23-6, θ<sub>JA</sub> ----- 208.2°C/W
- Junction Temperature ----- 150°C
- Lead Temperature (Soldering, 10 sec.) ----- 260°C
- Storage Temperature Range ----- -65°C to 150°C
- ESD Susceptibility (Note 3)
- HBM (Human Body Model) ----- 2kV

**Recommended Operating Conditions** (Note 4)

- Supply Input Voltage, VCC ----- 3V to 18V
- Junction Temperature Range ----- -40°C to 125°C
- Ambient Temperature Range ----- -40°C to 85°C

**Electrical Characteristics**

(V<sub>CC</sub> = 12V, No Load on any Output, T<sub>A</sub> = 25°C, unless otherwise specified)

Parameter	Symbol	Test Conditions	Min	Typ	Max	Unit
<b>Overall</b>						
Supply Current	I <sub>VCC</sub>		--	--	3	mA
VIN Under Voltage Lockout Threshold	V <sub>UVLO</sub>	V <sub>IN</sub> rising	2.1	2.55	3	V
		V <sub>IN</sub> falling	1.8	2.2	2.6	
Shutdown Current	I <sub>SHDN</sub>	V <sub>DCTL</sub> < 0.1V	--	--	10	μA
Enable Voltage	Logic-High	V <sub>DCTL_H</sub>	0.65	--	--	V
	Logic-Low	V <sub>DCTL_L</sub>	--	--	0.2	
<b>Current Sense Amplifier</b>						
Input Threshold (V <sub>VCC</sub> - V <sub>ISN</sub> )		V <sub>ACTL</sub> ≥ 1.25V	96	100	104	mV
Input Current	I <sub>ISN</sub>	V <sub>ISN</sub> = 12V	--	20	--	μA
<b>LED Dimming</b>						
Analog Dimming ACTL Pin Input Current	I <sub>ACTL</sub>	0.65 ≤ V <sub>ACTL</sub> ≤ 3V	-2	--	--	μA
LED Maximum Current on Threshold at ACTL	V <sub>ACTL_ON</sub>	(V <sub>VCC</sub> - V <sub>ISN</sub> ) = 100mV	--	1.33	1.4	V
LED Current Off Threshold at ACTL	V <sub>ACTL_OFF</sub>		0.57	0.65	0.72	V
DCTL Input Current	I <sub>DCTL</sub>	0.3V ≤ V <sub>DCTL</sub> ≤ 5V	--	0.5	--	μA

Parameter		Symbol	Test Conditions	Min	Typ	Max	Unit
DCTL Input Voltage	Logic-High	V <sub>DCTL_H</sub>		2	--	--	V
	Logic-Low	V <sub>DCTL_L</sub>		--	--	0.1	
<b>PWM Boost Converter</b>							
Switching Frequency		f <sub>sw</sub>		--	350	--	kHz
SW R <sub>DS(ON)</sub>				--	0.1	--	Ω
SW Current Limit		I <sub>LIM_SW</sub>		2	2.5	--	A
Over Voltage Protection		V <sub>CC_OVP</sub>		18.3	19.6	20.9	V
Over Voltage Hysteresis				--	0.6	--	V
<b>Temperature Protection</b>							
Thermal Shutdown Temperature		T <sub>SD</sub>		--	150	--	°C
Thermal Shutdown Hysteresis		ΔT <sub>SD</sub>		--	10	--	°C

**Note 1.** Stresses beyond those listed “Absolute Maximum Ratings” may cause permanent damage to the device. These are stress ratings only, and functional operation of the device at these or any other conditions beyond those indicated in the operational sections of the specifications is not implied. Exposure to absolute maximum rating conditions may affect device reliability.

**Note 2.**  $\theta_{JA}$  is measured under natural convection (still air) at  $T_A = 25^\circ\text{C}$  with the component mounted on a high effective-thermal-conductivity four-layer test board on a JEDEC 51-7 thermal measurement standard.

**Note 3.** Devices are ESD sensitive. Handling precaution is recommended.

**Note 4.** The device is not guaranteed to function outside its operating conditions.

深圳市金博能电子科技有限公司  
 张生 · 13823712510

Typical Application Circuit

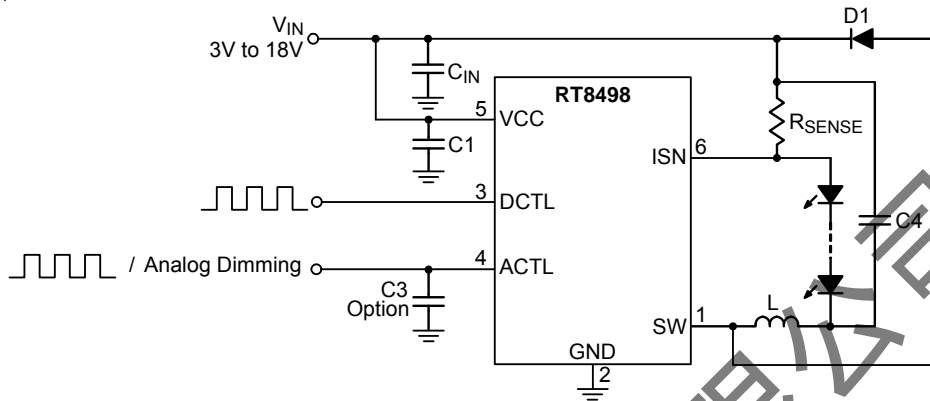

Figure 1. Buck Configuration

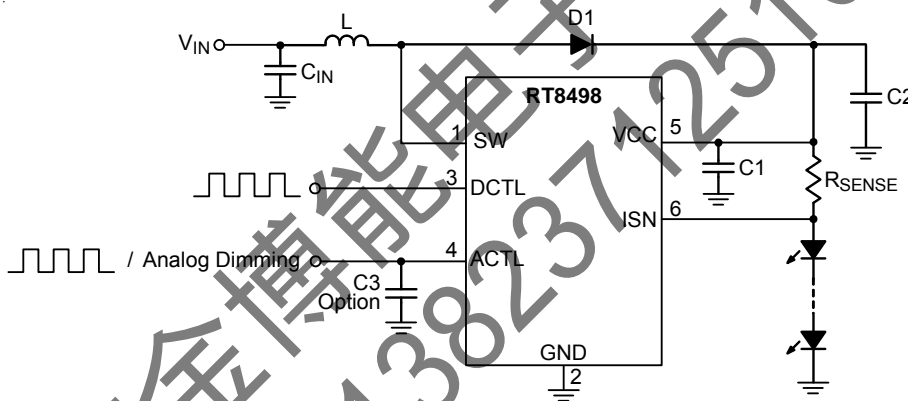

Figure 2. Boost Configuration

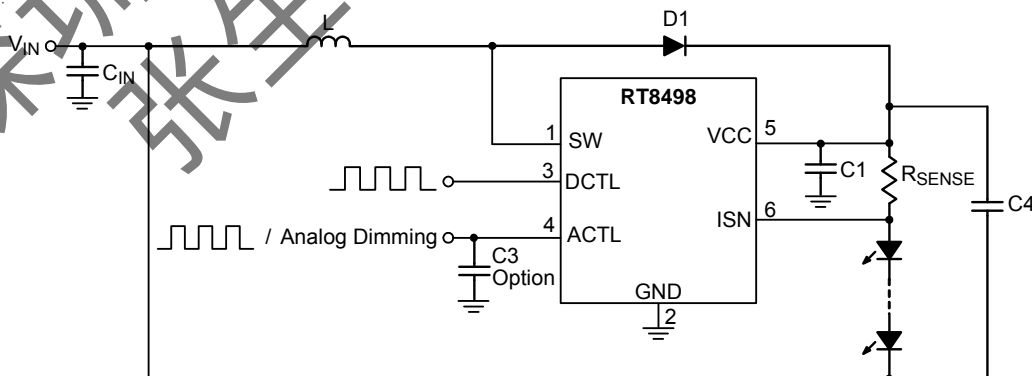
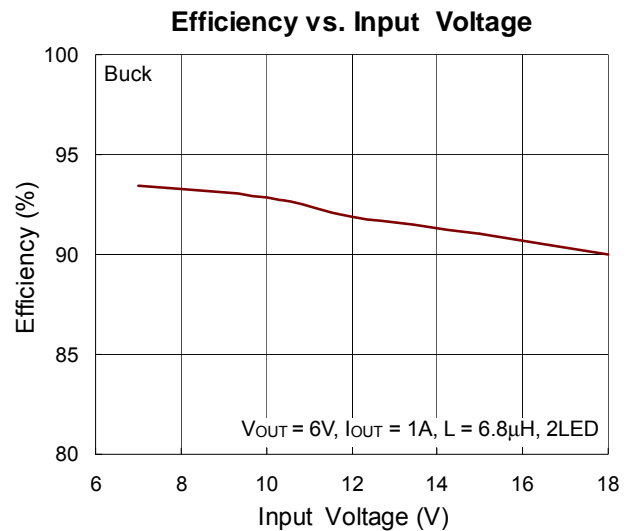
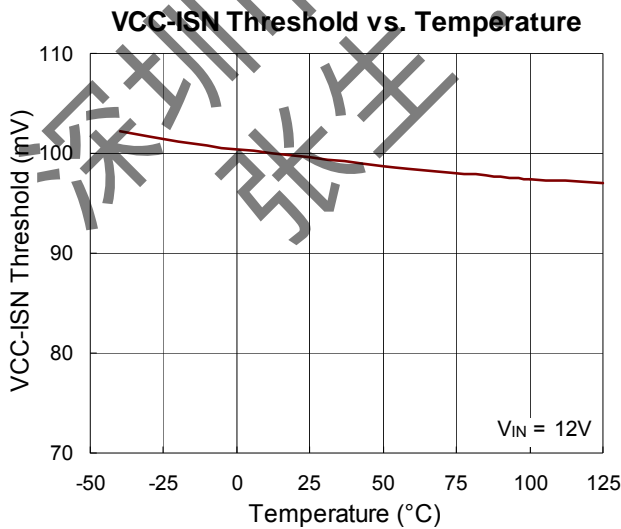
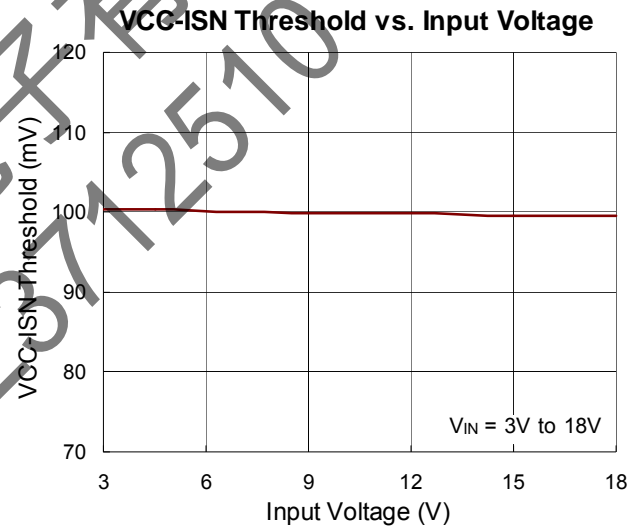
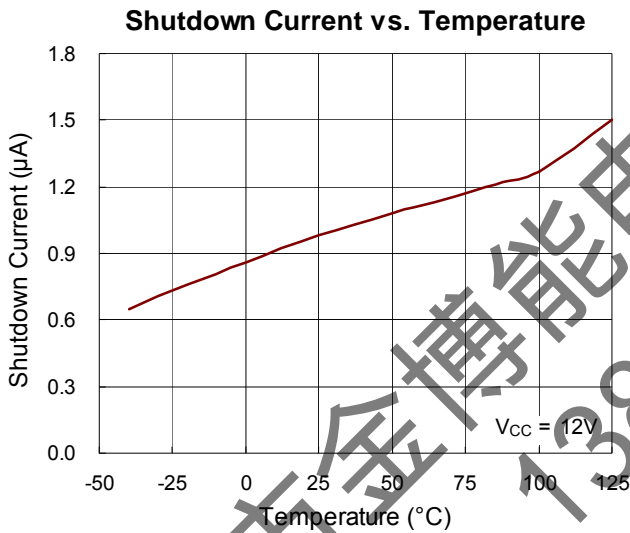
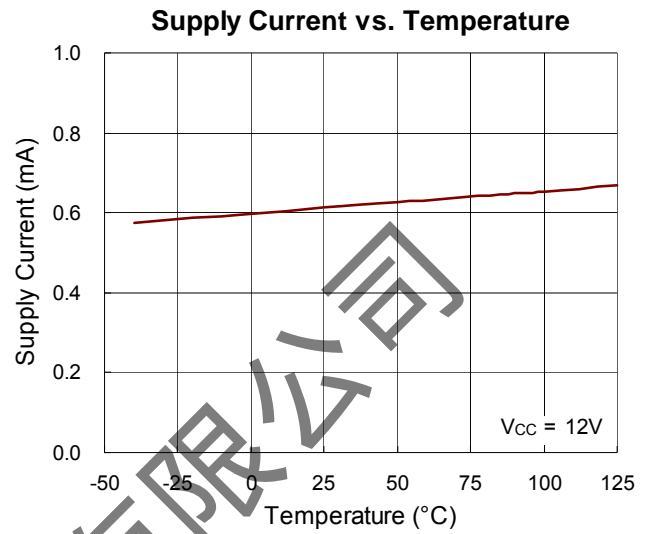
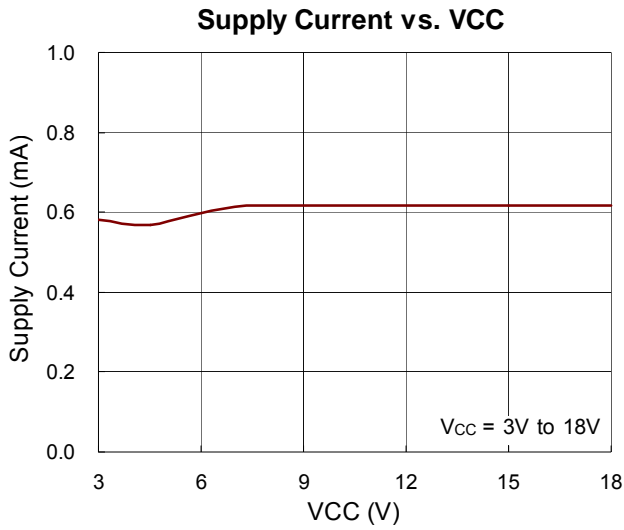
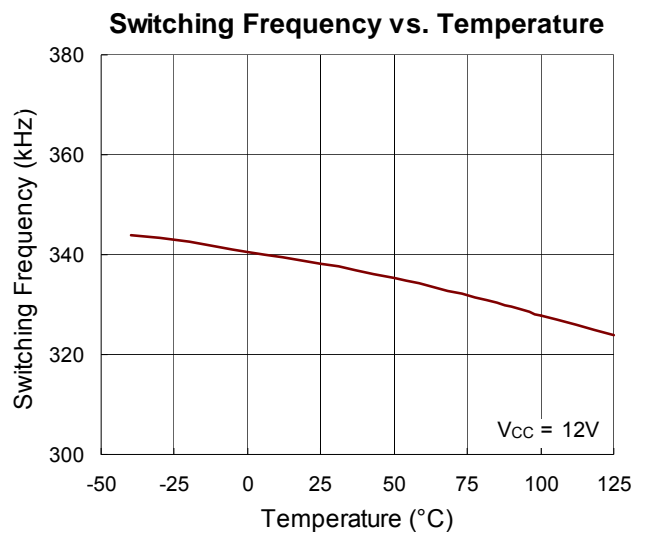
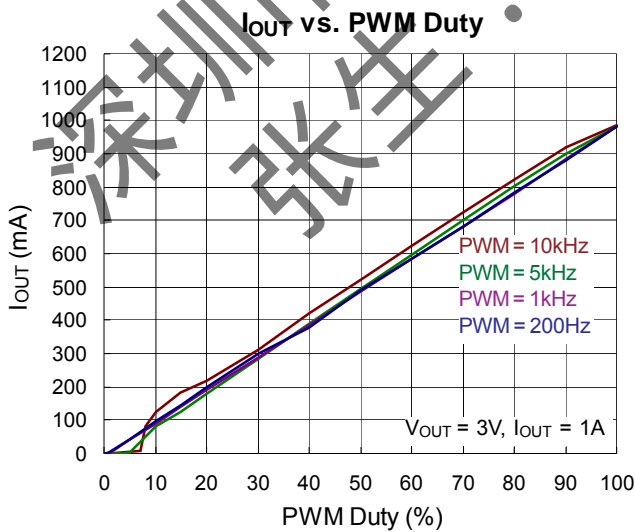
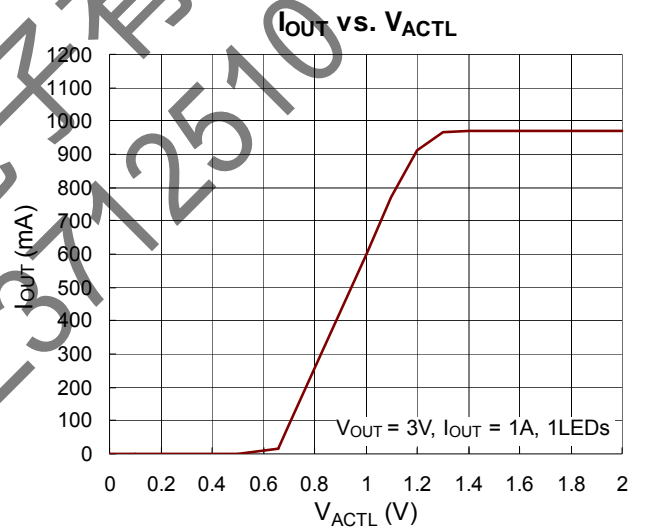
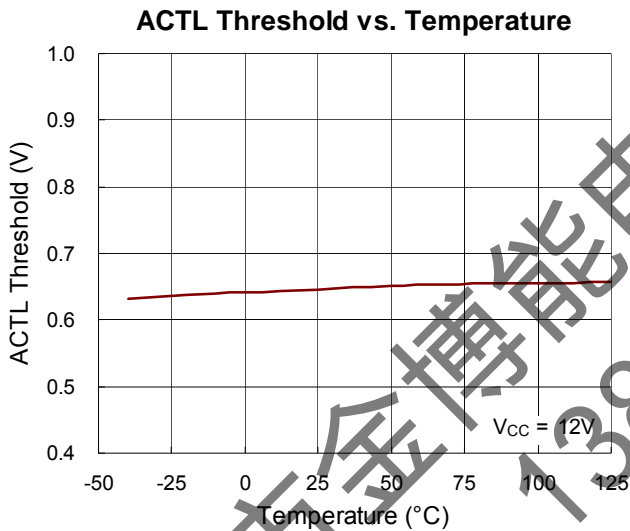
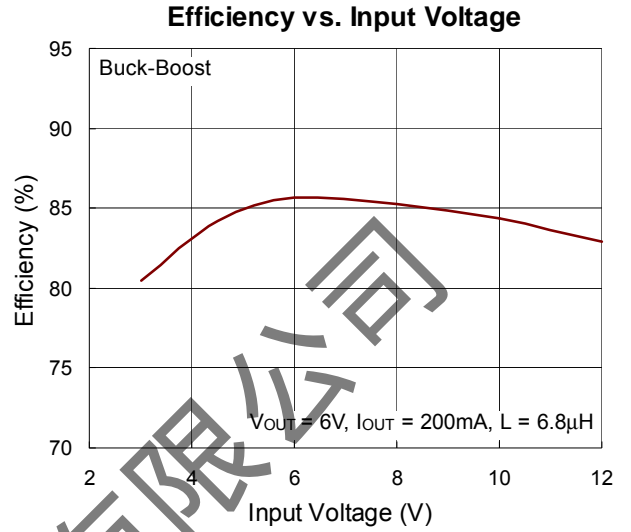
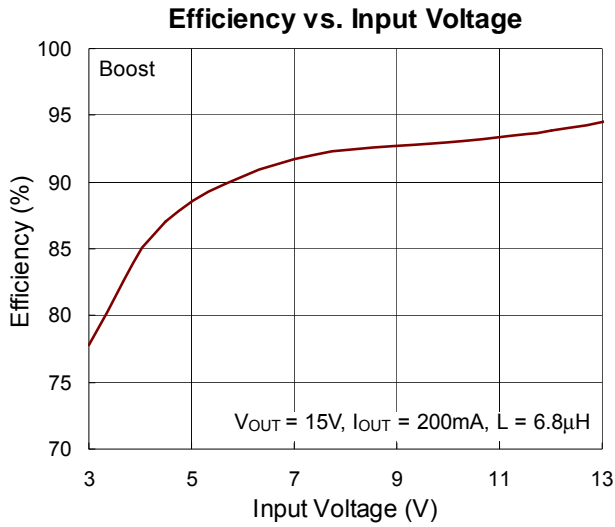

Figure 3. Buck-Boost Configuration

Typical Operating Characteristics





Power On from VIN

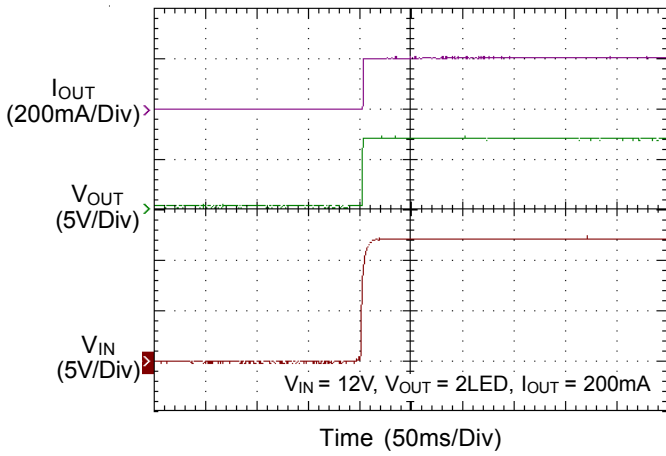

Power Off from VIN

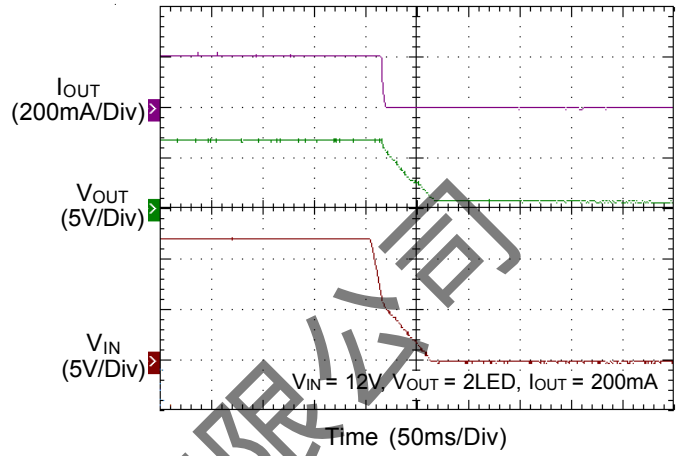

Power On from EN

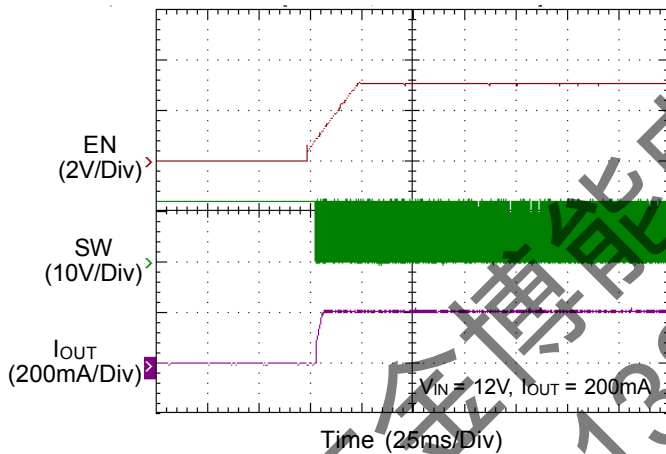

Power Off from EN

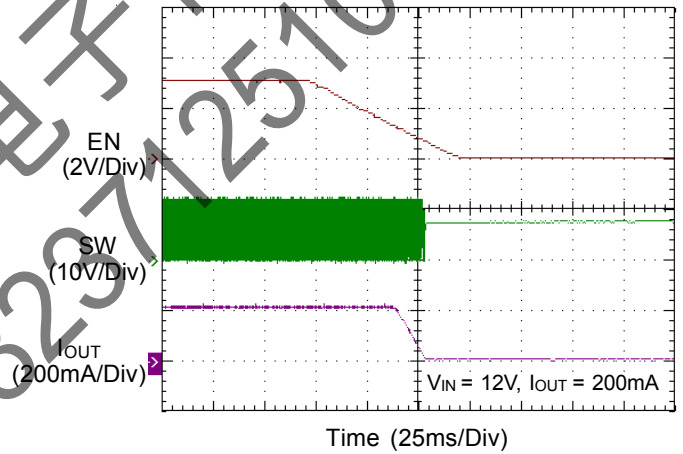

Start Up

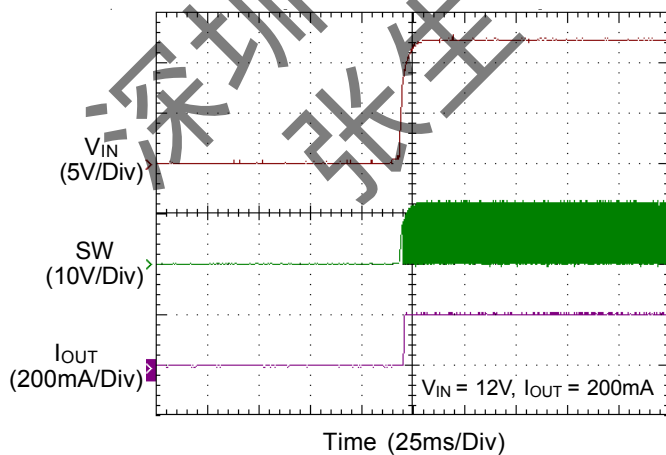

Shutdown

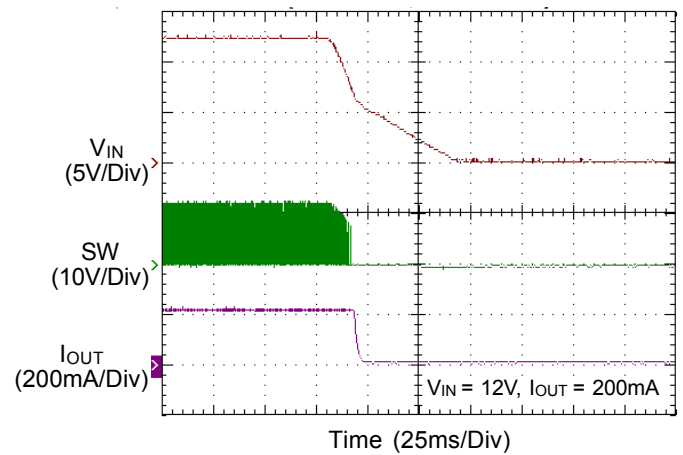



## Application Information

The RT8498 is specifically designed to be operated in Buck converter applications. This device uses a fixed frequency, current-mode control scheme to provide excellent line and load regulation.

### LED Current Setting

The LED current can be calculated by the following equation :

$$I_{LED(MAX)} = \frac{(V_{VCC} - V_{ISN})}{R_{SENSE}}$$

where  $(V_{VCC} - V_{ISN})$  is the voltage between the VCC and ISN pins (100mV typ. if ACTL dimming is not applied) and the  $R_{SENSE}$  is the resistor between the VCC and ISN pins.

### Current Limit

The RT8498 can limit the peak switch current with its internal over-current protection feature. In normal operation, the power switch is turned off when the switch current hits the loop-set value. The over-current protection function will turn off the power switch independent of the loop control when the peak switch current reaches around 2.5A (typ.).

### Over-Temperature Protection

The RT8498 has over-temperature protection (OTP) function to prevent the excessive power dissipation from overheating. The OTP function will shut down switching operation when the die junction temperature exceeds 150°C. The chip will automatically start to switch again when the die junction temperature cools off.

### Inductor Selection

Choose an inductor that can handle the necessary peak current without saturating and ensure that the inductor has a low DCR (copper-wire resistance) to minimize  $I^2R$  power losses. Inductor manufacturers specify the maximum current rating as the current where the inductance falls to certain percentage of its nominal value, typically 65%. In Multiple-Topology application where the transition between discontinuous and continuous modes

occurs, the value of the required output inductor, L, can be approximated by the following equation :

For Buck application :

$$L = \left[ \frac{V_{OUT}}{f \times \Delta I_L} \right] \times \left[ 1 - \frac{V_{OUT}}{V_{IN(MAX)}} \right]$$

The ripple current  $\Delta I_L$  and peak current  $I_{PEAK}$  can be calculated :

$$\Delta I_L = \left[ \frac{V_{OUT}}{f \times L} \right] \times \left[ 1 - \frac{V_{OUT}}{V_{IN}} \right]$$

$$I_{PEAK} = I_{OUT} + \frac{\Delta I_L}{2}$$

For Boost application :

$$L = \left[ \frac{V_{IN}}{f \times \Delta I_L} \right] \times \left[ 1 - \frac{V_{IN}}{V_{OUT}} \right]$$

The ripple current  $\Delta I_L$  and peak current  $I_{PEAK}$  can be calculated :

$$\Delta I_L = \left[ \frac{V_{IN}}{f \times L} \right] \times \left[ 1 - \frac{V_{IN}}{V_{OUT}} \right]$$

$$I_{PEAK} = \left[ \frac{I_{OUT} \times V_{OUT}}{\eta \times V_{IN}} \right] + \frac{\Delta I_L}{2}$$

For Buck-Boost application :

$$L = \left[ \frac{V_{OUT}}{\Delta I_L \times f} \right] \times \left[ 1 - \frac{V_{OUT}}{V_{IN} + V_{OUT}} \right]$$

The ripple current  $\Delta I_L$  and peak current  $I_{PEAK}$  can be calculated :

$$\Delta I_L = \left[ \frac{V_{OUT}}{L \times f} \right] \times \left[ 1 - \frac{V_{OUT}}{V_{IN} + V_{OUT}} \right]$$

$$I_{PEAK} = \left[ \frac{(V_{IN} + V_{OUT}) \times I_{OUT}}{\eta \times V_{IN}} \right] + \frac{\Delta I_L}{2}$$

where,

$V_{OUT}$  = output voltage.

$V_{IN}$  = input voltage.

$I_{OUT}$  = LED current.

$f$  = switching frequency.

$\eta$  = efficiency

### Schottky Diode Selection

The Schottky diode, with their low forward voltage drop and fast switching speed, is necessary for the RT8498 applications. In addition, power dissipation, reverse voltage rating and pulsating peak current are important parameters of the Schottky diode that must be considered. The diode's average current rating must exceed the average output current. The diode conducts current only when the power switch is turned off (typically less than 50% duty cycle).

### Thermal Considerations

The junction temperature should never exceed the absolute maximum junction temperature  $T_{J(MAX)}$ , listed under Absolute Maximum Ratings, to avoid permanent damage to the device. The maximum allowable power dissipation depends on the thermal resistance of the IC package, the PCB layout, the rate of surrounding airflow, and the difference between the junction and ambient temperatures. The maximum power dissipation can be calculated using the following formula :

$$P_{D(MAX)} = (T_{J(MAX)} - T_A) / \theta_{JA}$$

where  $T_{J(MAX)}$  is the maximum junction temperature,  $T_A$  is the ambient temperature, and  $\theta_{JA}$  is the junction-to-ambient thermal resistance.

For continuous operation, the maximum operating junction temperature indicated under Recommended Operating Conditions is 125°C. The junction-to-ambient thermal resistance,  $\theta_{JA}$ , is highly package dependent. For a SOT-23-6 package, the thermal resistance,  $\theta_{JA}$ , is 208.2°C/W on a standard JEDEC 51-7 high effective thermal-conductivity four-layer test board. The maximum power dissipation at  $T_A = 25^\circ\text{C}$  can be calculated as below :

$$P_{D(MAX)} = (125^\circ\text{C} - 25^\circ\text{C}) / (208.2^\circ\text{C/W}) = 0.48\text{W for a SOT-23-6 package.}$$

The maximum power dissipation depends on the operating ambient temperature for the fixed  $T_{J(MAX)}$  and the thermal resistance,  $\theta_{JA}$ . The derating curves in Figure 4 allows the designer to see the effect of rising ambient temperature on the maximum power dissipation.

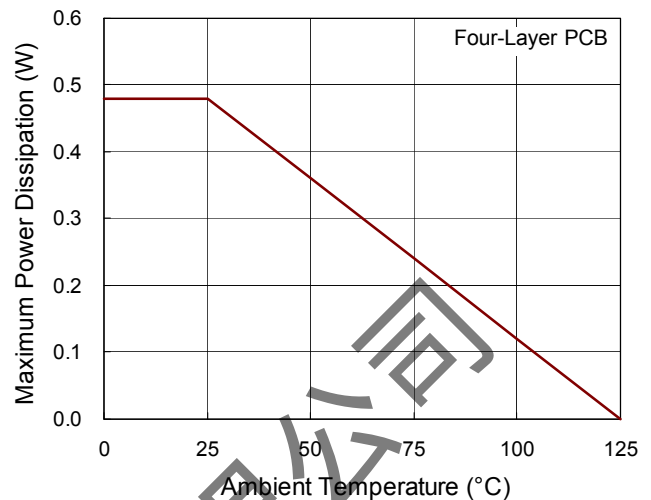

Figure 4. Derating Curve of Maximum Power Dissipation

### Layout Considerations

PCB layout is very important when designing power switching converter circuits. Some recommended layout guide lines are as follows :

- ▶ The power components L, D1 and C4 must be placed as close to each other as possible to reduce the ac current loop area. The PCB trace between power components must be as short and wide as possible due to large current flow through these traces during operation.
- ▶ The input capacitor C1 must be placed as close to the VCC pin as possible.

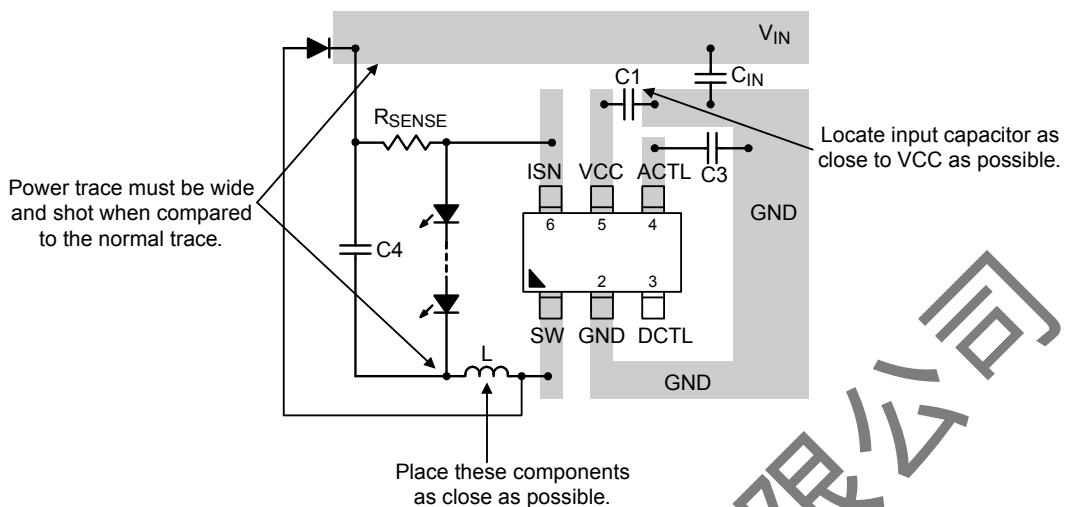
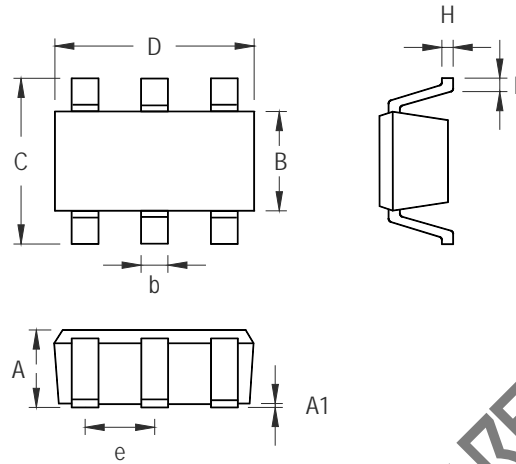

Figure 5. PCB Layout Guide

深圳市金博能电子有限公司  
张生：13823712510

Outline Dimension



Symbol	Dimensions In Millimeters		Dimensions In Inches	
	Min	Max	Min	Max
A	0.889	1.295	0.031	0.051
A1	0.000	0.152	0.000	0.006
B	1.397	1.803	0.055	0.071
b	0.250	0.560	0.010	0.022
C	2.591	2.997	0.102	0.118
D	2.692	3.099	0.106	0.122
e	0.838	1.041	0.033	0.041
H	0.080	0.254	0.003	0.010
L	0.300	0.610	0.012	0.024

SOT-23-6 Surface Mount Package

Richtek Technology Corporation

14F, No. 8, Tai Yuen 1<sup>st</sup> Street, Chupei City  
 Hsinchu, Taiwan, R.O.C.  
 Tel: (8863)5526789

Richtek products are sold by description only. Richtek reserves the right to change the circuitry and/or specifications without notice at any time. Customers should obtain the latest relevant information and data sheets before placing orders and should verify that such information is current and complete. Richtek cannot assume responsibility for use of any circuitry other than circuitry entirely embodied in a Richtek product. Information furnished by Richtek is believed to be accurate and reliable. However, no responsibility is assumed by Richtek or its subsidiaries for its use; nor for any infringements of patents or other rights of third parties which may result from its use. No license is granted by implication or otherwise under any patent or patent rights of Richtek or its subsidiaries.