



# Optical Sensor Product Data Sheet LTR-507ALS-01

Spec No.: DS86-2013-0014

Effective Date: 07/09/2014

Revision: A

**LITE-ON DCC**

**RELEASE**

BNS-OD-FC001/A4

## Optical Sensor LTR-507ALS-01

### Description

The LTR-507ALS-01 is an integrated I2C digital light sensor [ALS] and proximity sensor [PS] with built-in LED driver, in a miniature chip lead-free surface mount package. This device converts light intensity to a digital output signal capable of direct I2C interface. It provides a linear response over a wide dynamic range and is well suited to applications under high ambient brightness. With built-in proximity sensor, LTR-507ALS-01 offers the feature to detect object at a user configurable distance of typical 50cm Gray Card.

The device supports an interrupt feature that removes the need to poll the sensor for a reading which improves system efficiency. The device also supports several features that help to minimize the occurrence of false triggering. This CMOS design and factory-set one time trimming capability ensure minimal device-to-device variations for ease of manufacturability to the end customers.

### Application

To control display backlight and/or object detection in

- Mobile Devices: Mobile phone, PDA
- Computing Devices: Notebook PC, Desktop Monitor
- Consumer Devices: LCD/PDP TV backlight systems, Cameras, Personal Navigation Device, Digital Photo Frame
- Dashboard

### Features

- I2C interface (Standard mode@100kbit/s, Fast Mode@400kbit/s and High Speed Mode@3.4Mbit/s)
- Built-in temperature compensation circuit
- Programmable independent thresholds and interrupts
- Low active power consumption with shutdown mode
- Supply voltage range from 2.4V to 3.6V capable of 1.7 V logic voltage
- Operating temperature range from -40°C to +85°C
- RoHS and Halogen free compliant
- **Light Sensor Features**
  - Close to human eye spectral response
  - 4 Gain Range Selections
  - Works under different light source conditions
  - Automatically rejects 50/60Hz lightings flicker
- **Proximity Sensor Features**
  - Built-in LED driver and detector
  - Programmable LED drive settings
  - 11-bit effective resolution
  - High ambient light suppression

### Ordering Information

Part Number	Packaging Type	Package	Quantity
LTR-507ALS-01	Tape and Reel	8-pin chip lead package	2000

**Optical Sensor  
LTR-507ALS-01**

**1. Outline Dimensions**

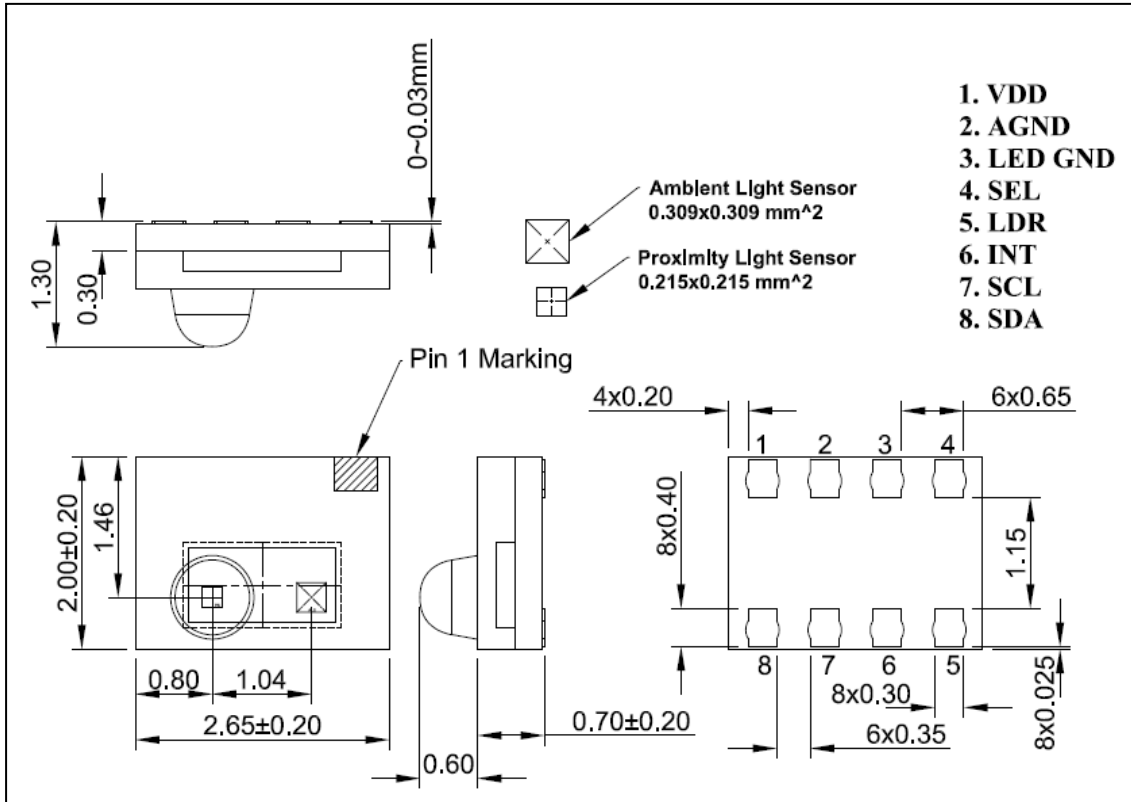

**Note:**

- All dimensions are in millimeters

### 2. Functional Block Diagram

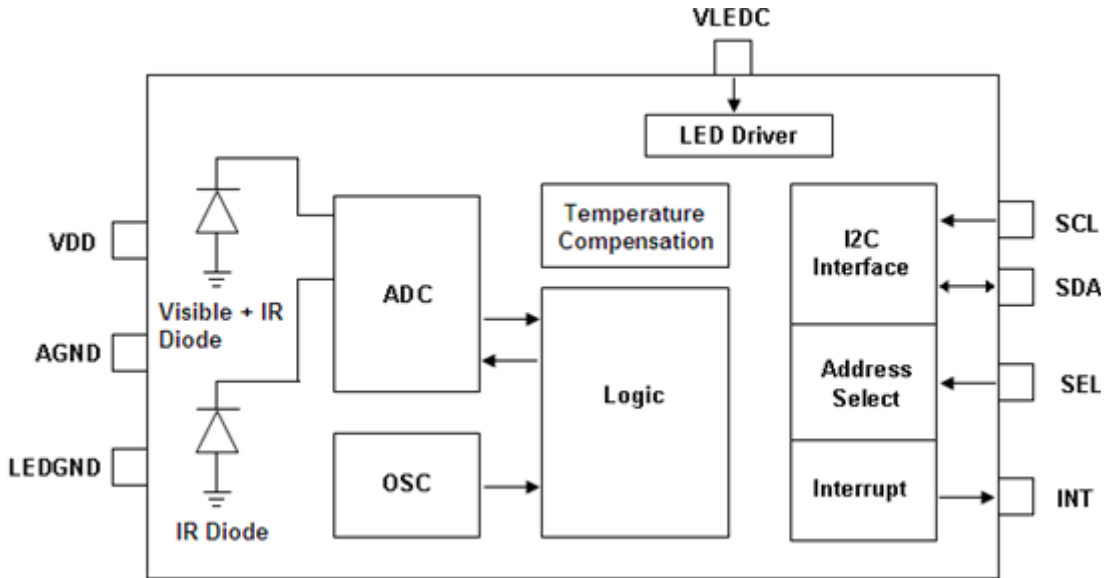

### 3. Application Circuit

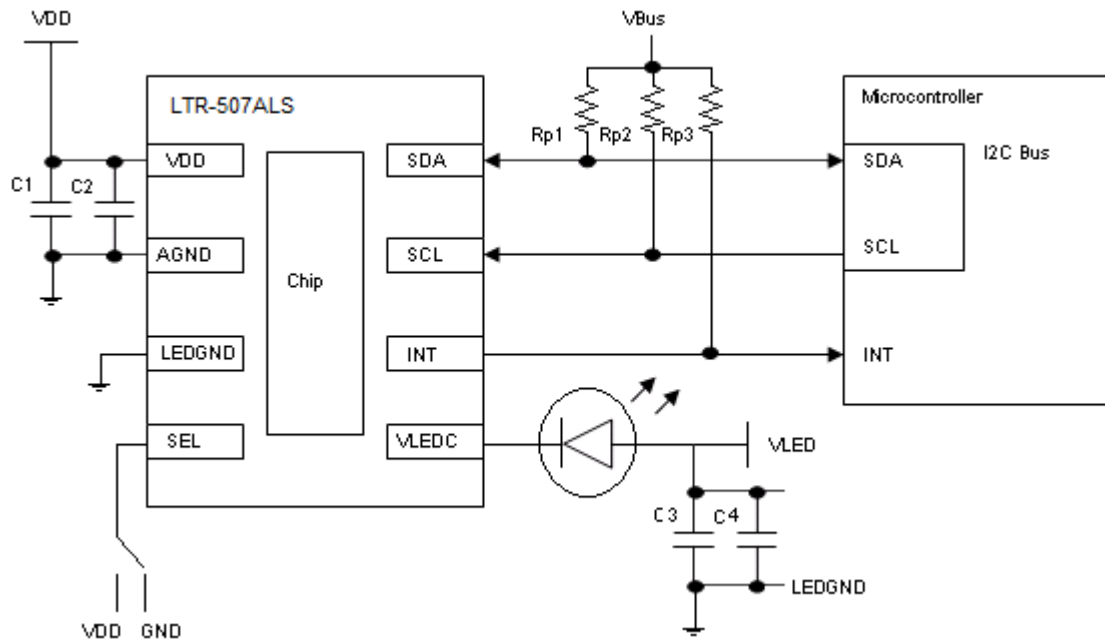

## Optical Sensor LTR-507ALS-01

**I/O Pins Configuration Table**

Pin	I/O Type	Symbol	Description
1		VDD	Supply Voltage
2		AGND	Analog Ground
3		LEDGND	LED GND
4	I	SEL	I2C address selection
5	I	VLEDC	To connect to LED Cathode.
6	O	INT	Level Interrupt pin. Active LOW for interrupt. This pin is an open drain.
7	I	SCL	I2C serial clock

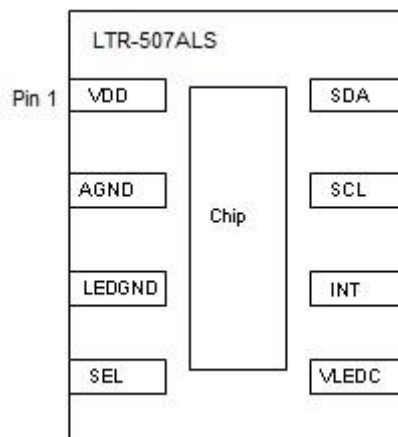

8	I/O	SDA	I2C serial data
---	-----	-----	-----------------

### Recommended Application Circuit Components

Component	Recommended Value
Rp1, Rp2, Rp3 [1]	1 kΩ to 10 kΩ
C1, C3	0.1uF
C2, C4	4.7uF

#### Notes:

[1] Selection of pull-up resistors value is dependent on bus capacitance values. For more details, please refer to I2C Specifications: [http://www.nxp.com/documents/user\\_manual/UM10204.pdf](http://www.nxp.com/documents/user_manual/UM10204.pdf)

[2] IR LED = LTE-C249

### 4. Rating and Specification

#### 4.1. Absolute Maximum Rating at Ta=25°C

Parameter	Symbol	Rating	Unit
Supply Voltage	VDD	4.5	V
I2C Address Pin Voltage	SEL	-0.2 to 4.5	V
I2C Bus Pin Voltage	SCL, SDA	-0.2 to 4.5	V
I2C Bus Pin Current	SCL, SDA	10	mA
Storage Temperature	T <sub>stg</sub>	-40 to 100	°C

Note: Exceeding these ratings could cause damage to the sensor. All voltages are with respect to ground. Currents are positive into, negative out of the specified terminal.

#### 4.2. Recommended Operating Conditions

Description	Symbol	Min.	Typ.	Max.	Unit
Supply Voltage	VDD	2.4		3.6	V
LED Supply Voltage	V <sub>LED</sub>	2.5		4.35	V
I2C Bus Pin Voltage	V <sub>bus</sub>	1.7		3.6	V
I2C Bus Input Pin High Voltage	VIH_SCL, VIH_SDA	1.3			V
I2C Bus Input Pin Low Voltage	VIL_SCL, VIL_SDA			0.3	V
Operating Temperature	T <sub>ope</sub>	-40		85	°C

#### 4.3. Electrical & Optical Specifications

All specifications are at VDD = 3.0V, T<sub>ope</sub> = 25°C, unless otherwise noted.

Parameter	Min.	Typ.	Max.	Unit	Condition
Active Supply Current			220	uA	Active Mode, T <sub>ope</sub> = 25°C
Standby Current			5	uA	Standby / Sleep Mode
Initial Startup Time	100			ms	(Note 1)
Wakeup Time from Standby			10	ms	(Note 1)

## Optical Sensor LTR-507ALS-01

### 4.4. Characteristics Ambient Sensor

Parameter	Min.	Typ.	Max.	Unit	Condition
Full Scale ADC Count	0		65535	count	
Dark ADC Count	0		3	count	E = 0 lux, Dynamic range 1
CH1 Count	90		180	count	E=200 lux white LED (10K color temperature), Dynamic range 1, 1 to 64kux, 16 bit ADC
CH2 Count	25		55	count	E=200 lux white LED (10K color temperature), Dynamic range 1, 1 to 64kux, 16 bit ADC
Gain 2x	-5%		5%		Dynamic range 1
Gain 100x	-5%		5%		Dynamic range 1
Gain 200x	-5%		5%		Dynamic range 1

### 4.5. Characteristics Proximity Sensor

Parameter	Min.	Typ.	Max.	Unit	Condition
Full Scale ADC Count			2047	count	
Peak Sensitivity		850		nm	
Detection Distance		50		cm	18% Gray card IR LED=LTE-C249, 127 IR pulses
Ambient Light Suppression			50k	lux	Direct sunlight
LED Pulse Count	1		255	pulses	
LED Pulse Frequency	30k		100k	Hz	Increment of 10k Hz
LED Duty Cycle		50%		%	Fixed at 50% Duty Cycle
LED Peak Current		5		mA	LED Peak Current = 000
		10		mA	LED Peak Current = 001
		20		mA	LED Peak Current = 010
		50		mA	LED Peak Current = 011
	65		130	mA	LED Peak Current = 100/101/110/111

**Notes:**

1. Startup Sequence

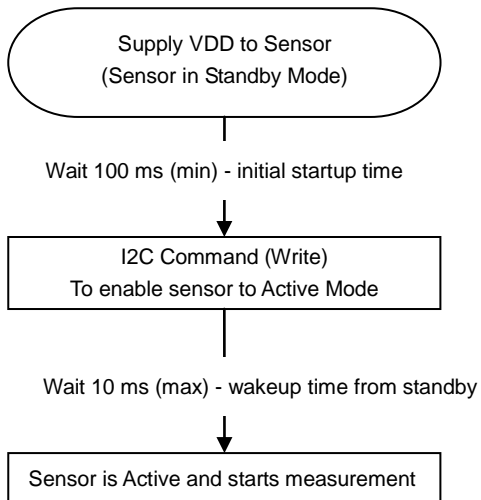



4.6. Typical Performance Curve, VDD = 3.0V, Ta=25°C

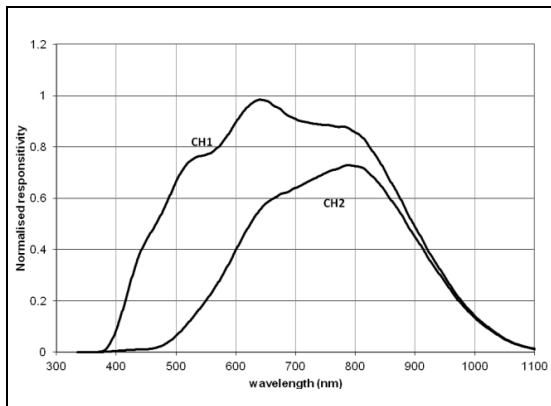

Figure 4.1 : Spectral responsivity.

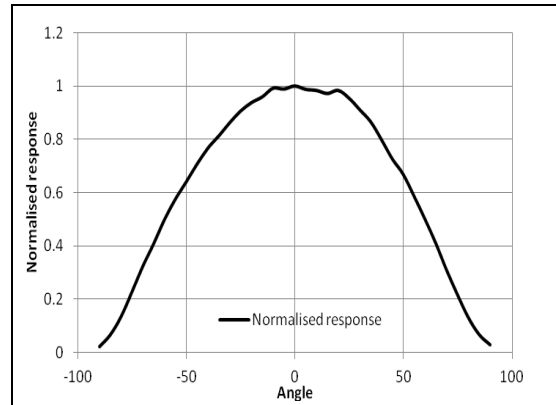

Figure 4.2 : Ambient sensor angular displacement.

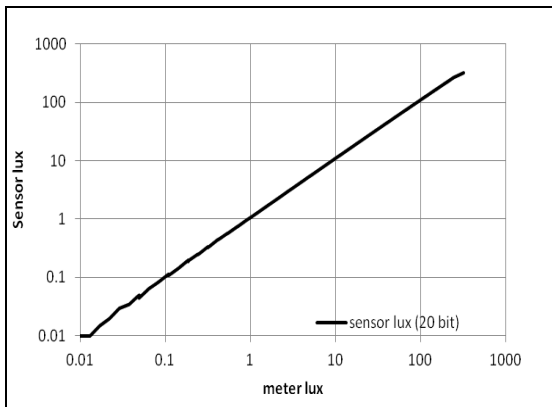

Figure 4.3: Sensor lux versus meter lux with low lux white LED source, Gain 4.

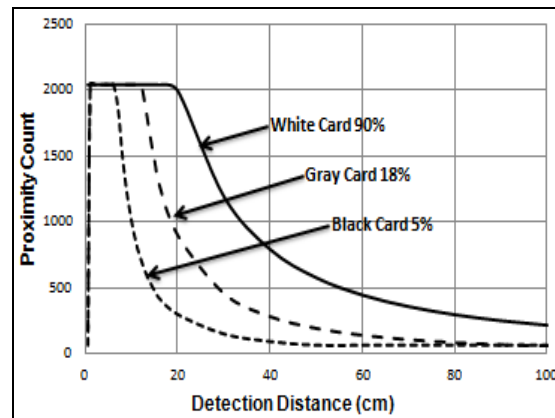

Figure 4.4 : Proximity ADC output versus detection distance (127 pulses).

## Optical Sensor LTR-507ALS-01

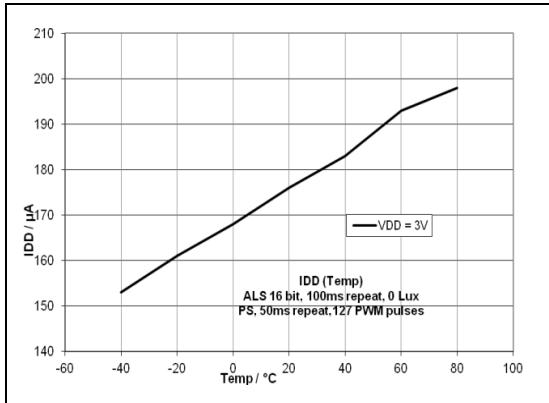

Figure 4.5 : Supply current versus temperature sensing

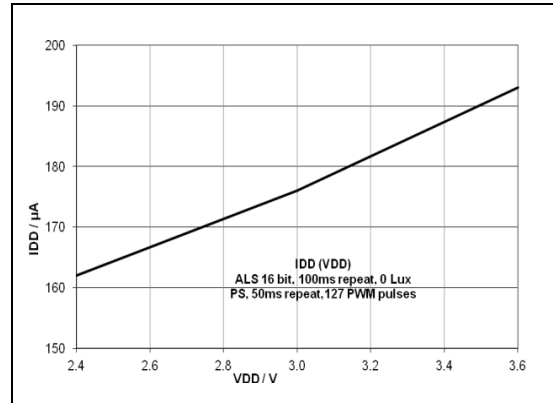
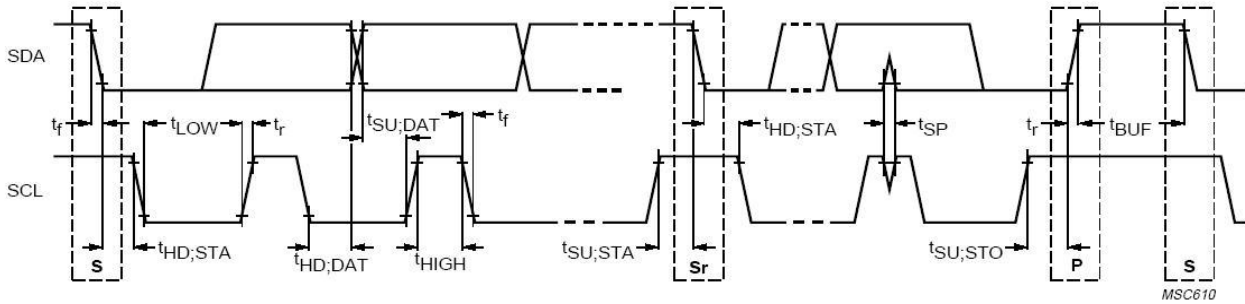

Figure 4.6: Supply current versus supply voltage

### 4.7. AC Electrical Characteristics

All specifications are at VBus = 1.7V, T<sub>ope</sub> = 25°C, unless otherwise noted.

Parameter	Symbol	Min	Fast (Min)	Unit	
SCL clock frequency	$f_{SCL}$	100	400	3400	KHz
Bus free time between a STOP and START condition	$t_{BUF}$	1.3			us
Hold time (repeated) START condition. After this period, the first clock pulse is generated	$t_{HD;STA}$	0.6			us
LOW period of the SCL clock	$t_{LOW}$	1.3			us
HIGH period of the SCL clock	$t_{HIGH}$	0.6			us
Set-up time for a repeated START condition	$t_{SU;STA}$	0.6			us
Set-up time for STOP condition	$t_{SU;STO}$	0.6			us
Rise time of both SDA and SCL signals	$t_r$	30	300		ns
Fall time of both SDA and SCL signals	$t_f$	30	300		ns
Data hold time	$t_{HD;DAT}$	0	0.9		us
Data setup time	$t_{SU;DAT}$	100			ns
Pulse width of spikes which must be suppressed by the input filter	$t_{SP}$	0	50		ns



Definition of timing for I<sup>2</sup>C bus

## 5. Principle of Operation

### 5.1. I2C Protocol

#### 5.1.1. I2C Write Protocol (type 1)

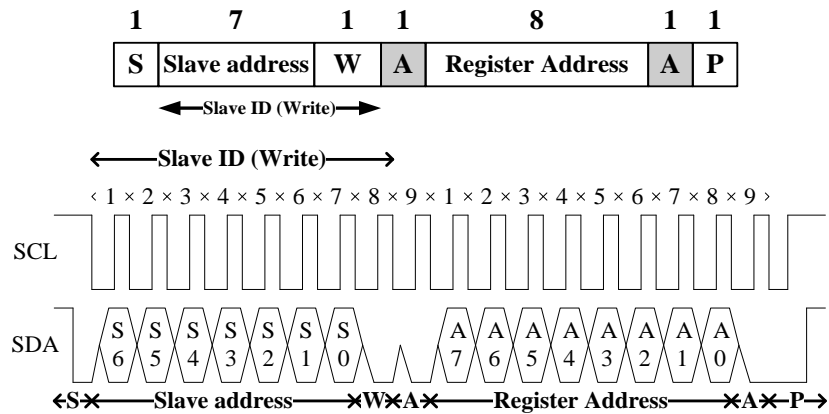

### 5.1.2. I2C Write Protocol (type 2)

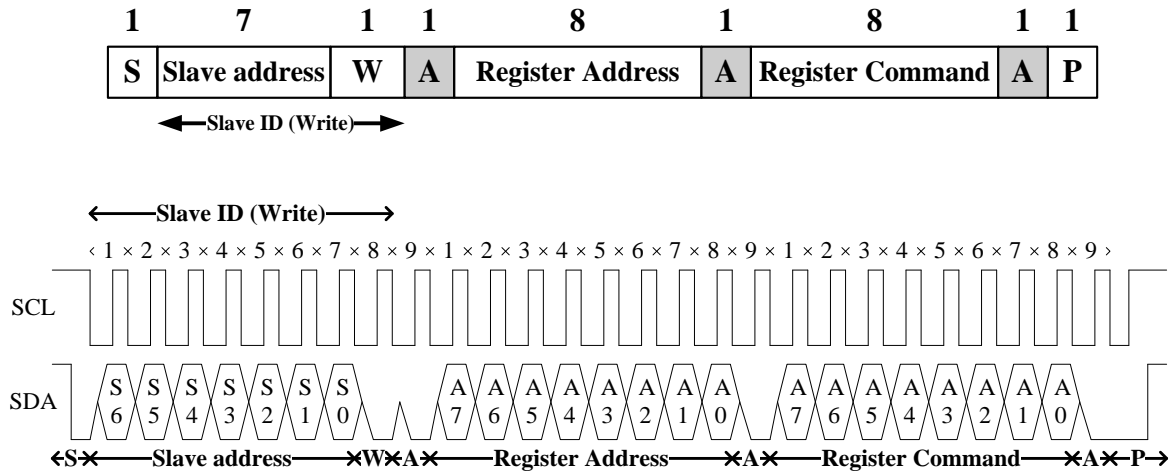

### 5.1.3. I2C Read Protocol

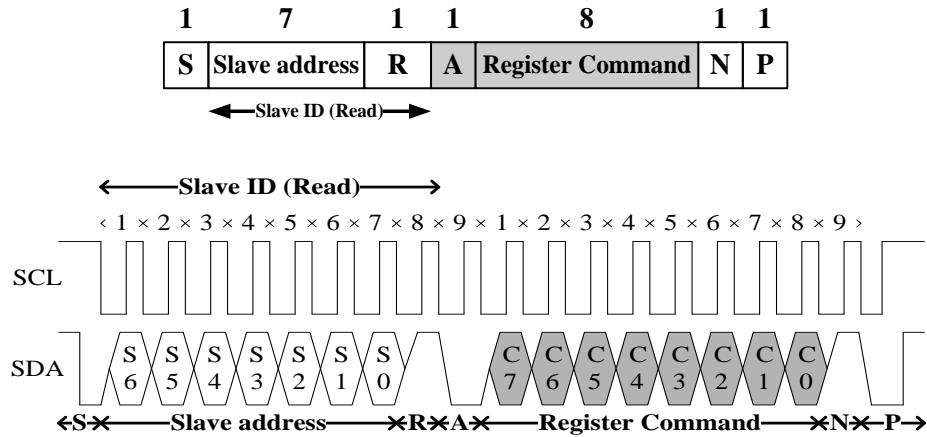

**Optical Sensor  
LTR-507ALS-01**

5.1.4. I2C Read (Combined format) Protocol

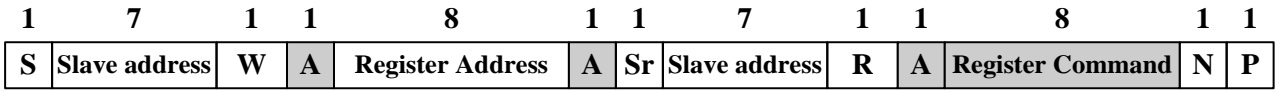

← Slave ID (Write) →

← Slave ID (Read) →

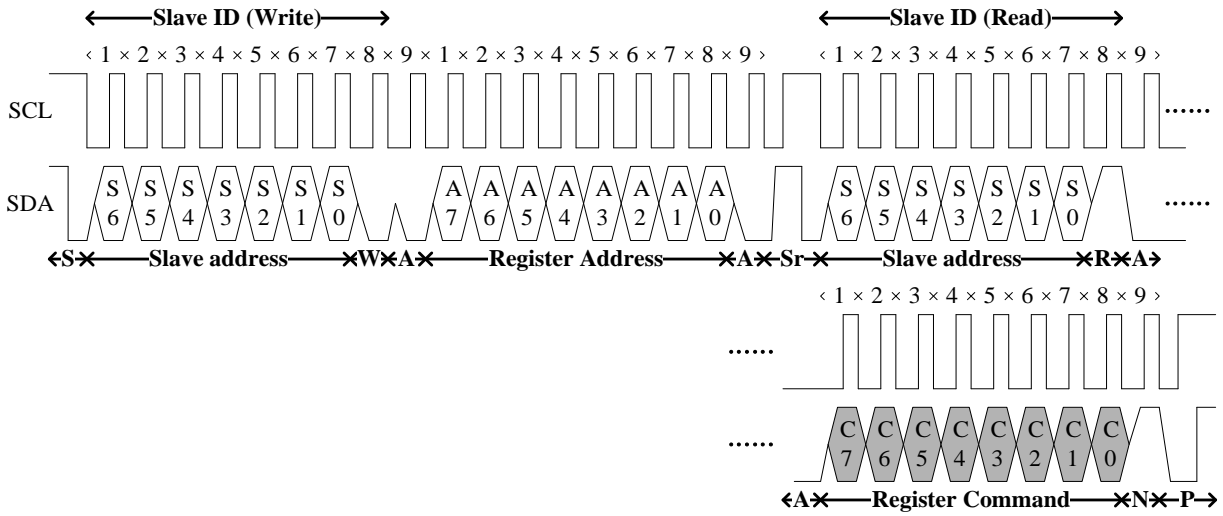

- A** Acknowledge (0 for an ACK)
- S** Start condition
- P** Stop condition
- W** Write (0 for writing)
- Slave-to-master

- N** Non-Acknowledge(1 for an NACK)
- Sr** Repeated Start condition
- R** Read (1 for read)
- Master-to-Slave

### 5.2. I2C Slave Address

The device offers three slave addresses that are selectable via pin 4 (SEL). The slave addresses are 7 bits. A read/write bit should be appended to the slave address by the master device to properly communicate with the device.

(1) SEL Pin is "GND" :

I <sup>2</sup> C Slave Address (SEL = GND)									
Command Type	(0x3AH)							W/R	value
	Bit 7	Bit 6	Bit 5	Bit 4	Bit 3	Bit 2	Bit 1	Bit 0	
Write	0	1	1	1	0	1	0	0	0x74H
Read	0	1	1	1	0	1	0	1	0x75H

(2) SEL Pin is "VDD" :

I <sup>2</sup> C Slave Address (SEL = VDD)									
Command Type	(0x3BH)							W/R	value
	Bit 7	Bit 6	Bit 5	Bit 4	Bit 3	Bit 2	Bit 1	Bit 0	
Write	0	1	1	1	0	1	1	0	0x76H
Read	0	1	1	1	0	1	1	1	0x77H

(3) SEL Pin is "Float" :

I <sup>2</sup> C Slave Address (SEL = Float)									
Command Type	(0x23H)							W/R	value
	Bit 7	Bit 6	Bit 5	Bit 4	Bit 3	Bit 2	Bit 1	Bit 0	
Write	0	1	0	0	0	1	1	0	0x46H
Read	0	1	0	0	0	1	1	1	0x47H

### 6. Register Set

Address	R / W	Register Name	Description	Reset Value
0x80	R / W	ALS_CONTR	ALS operation mode control SW reset	0x00
0x81	R / W	PS_CONTR	PS operation mode control	0x0C
0x82	R / W	PS_LED	PS LED setting	0x6B
0x83	R / W	PS_N_PULSES	PS number of pulses	0x7F
0x84	R / W	PS_MEAS_RATE	PS measurement rate in active mode	0x03
0x85	R / W	ALS_MEAS_RATE	ALS measurement rate in active mode	0x82
0x86	R	PART_ID	Part Number ID and Revision ID	0x91
0x87	R	MANUFAC_ID	Manufacturer ID	0x05
0x88	R	ALS_DATA_0	Direct ALS measurement, lower byte	0x00
0x89	R	ALS_DATA_1	Direct ALS measurement, upper byte	0x00
0x8A	R	ALS_PS_STATUS	ALS and PS new data status	0x00
0x8B	R	PS_DATA_0	PS measurement data, lower byte	0x00
0x8C	R	PS_DATA_1	PS measurement data, upper byte	0x00
0x8D	R	ALS_DATA_CH1_0	ALS measurement CH1 data, lower byte	0x00
0x8E	R	ALS_DATA_CH1_1	ALS measurement CH1 data, mid byte	0x00
0x8F	R	ALS_DATA_CH1_2	ALS measurement CH1 data, upper byte	0x00
0x90	R	ALS_DATA_CH2_0	ALS measurement CH2 data, lower byte	0x00
0x91	R	ALS_DATA_CH2_1	ALS measurement CH2 data, mid byte	0x00
0x92	R	ALS_DATA_CH2_2	ALS measurement CH2 data, upper byte	0x00
0x93	R / W	ALS_COEFF1_DATA_0	Coefficient for Clear diode, lower byte	0x80
0x94	R / W	ALS_COEFF1_DATA_1	Coefficient for Clear diode, upper byte	0x03
0x95	R / W	ALS_COEFF2_DATA_0	Coefficient for IR diode, lower byte	0xC8
0x96	R / W	ALS_COEFF2_DATA_1	Coefficient for IR diode, upper byte	0xFB
0x97	R / W	ALS_IRF_CUT_OFF	ALS cut-off limit of IR factor	0xD0
0x98	R / W	INTERRUPT	Interrupt settings	0x08
0x99	R / W	PS_THRES_UP_0	PS interrupt upper threshold, lower byte	0xFF
0x9A	R / W	PS_THRES_UP_1	PS interrupt upper threshold, upper byte	0x07
0x9B	R / W	PS_THRES_LOW_0	PS interrupt lower threshold, lower byte	0x00

## Optical Sensor LTR-507ALS-01

0x9C	R / W	PS_THRES_LOW_1	PS interrupt lower threshold, upper byte	0x00
0x9E	R / W	ALS_THRES_UP_0	ALS interrupt upper threshold, lower byte	0xFF
0x9F	R / W	ALS_THRES_UP_1	ALS interrupt upper threshold, upper byte	0xFF
0xA0	R / W	ALS_THRES_LOW_0	ALS interrupt lower threshold, lower byte	0x00
0xA1	R / W	ALS_THRES_LOW_1	ALS interrupt lower threshold, upper byte	0x00
0xA4	R / W	INTERRUPT PERSIST	ALS / PS Interrupt persist setting	0x00



## Optical Sensor LTR-507ALS-01

### 6.1. ALS\_CONTR Register (Address: 0x80)

The ALS\_CONTR register controls the ALS operation modes and software (SW) reset for the sensor. The ALS sensor can be set to either standby mode or active mode. At either of these modes, the I2C circuitry is always active. The default mode after power up is standby mode. During standby mode, there is no ALS measurement performed but I2C communication is allowed to enable read/write to all the registers

0x80	ALS_CONTR (default = 0x00)							
	Bit 7	Bit 6	Bit 5	Bit 4	Bit 3	Bit 2	Bit 1	Bit 0
	<i>Reserved</i>			<i>ALS Gain</i>		<i>SW Reset</i>	<i>ALS Mode</i>	<i>Reserved</i>

Field	BITS	Description
Reserved	7:5	Must write as 0
ALS Gain	4:3	00: Dynamic Range 1 (1 lux to 64k lux) (1 lux / count) (default) 01: Dynamic Range 2 (0.5 lux to 32k lux) (0.5 lux / count) 10: Dynamic Range 3 (0.02 lux to 640 lux) (0.01 lux / count) 11: Dynamic Range 4 (0.01 lux to 320 lux) (0.005 lux / count)
SW Reset	2	0: Software reset is NOT started (default) 1: Software reset is started, default value after reset is 0
ALS Mode	1	0: Standby Mode (default) 1: Active Mode
Reserved	0	Must write as 0

### 6.2. PS\_CONTR Register (0x81)

The PS\_CONTR register controls the PS operation modes. The PS sensor can be set to either standby mode or active mode. At either of these modes, the I2C circuitry is always active. The default mode after power up is standby mode. During standby mode, there is no ALS measurement performed but I2C communication is allowed to enable read/write to all the registers.

0x81	PS_CONTR (default = 0x0C)							
	Bit 7	Bit 6	Bit 5	Bit 4	Bit 3	Bit 2	Bit 1	Bit 0
	<i>Reserved</i>				<i>PS Gain</i>		<i>PS Mode</i>	<i>Reserved</i>

Field	BITS	Description
Reserved	7:4	Must write as 0
PS Gain	3:2	Must write as 11
PS Mode	1	0: Standby Mode (default) 1: Active Mode
Reserved	0	Must write as 0

### 6.3. PS\_LED Register (0x82)

The PS\_LED register controls the LED pulse modulation frequency, LED current duty cycle and LED peak current.

0x82	PS_LED (default = 0x6B)							
	Bit 7	Bit 6	Bit 5	Bit 4	Bit 3	Bit 2	Bit 1	Bit 0
	<i>LED Pulse Frequency</i>			<i>LED Duty Cycle</i>		<i>LED Peak Current</i>		

Field	BITS	Description
LED Pulse Frequency	7:5	000: 30k Hz 001: 40k Hz 010: 50k Hz 011: 60k Hz (default) 100: 70k Hz 101: 80k Hz 110: 90k Hz 111: 100k Hz
LED Duty Cycle	4:3	Must write as 01
LED Peak Current	2:0	000: 5mA 001: 10mA 010: 20mA 011: 50mA (default) Others: 100mA

### 6.4. PS\_N\_Pulses Register (0x83)

The PS\_N\_Pulses register controls the number of LED pulses to be emitted.

0x83	PS_N_Pulses (default = 0x7F)							
	Bit 7	Bit 6	Bit 5	Bit 4	Bit 3	Bit 2	Bit 1	Bit 0
	<i>LED Pulse Count</i>							

Field	BITS	Description
LED Pulse Count	7:0	0000 0000: Number of pulses = 0 0000 0001: Number of pulses = 1 0000 0010: Number of pulses = 2 ... 0111 1111: Number of pulses = 127 (default) ... 1111 1110: Number of pulses = 254 1111 1111: Number of pulses = 255

### 6.5. PS\_MEAS\_RATE Register (0x84)

The PS\_MEAS\_RATE register controls the timing of the periodic measurements of the PS in active mode. PS Measurement Repeat Rate is the interval between PS\_DATA registers update.

0x84	PS_MEAS_RATE (default = 0x03)							
	Bit 7	Bit 6	Bit 5	Bit 4	Bit 3	Bit 2	Bit 1	Bit 0
	<i>Reserved</i>					<i>PS Measurement Repeat Rate</i>		

Field	BITS	Description
Reserved	7:3	Must write as 0
PS Measurement Repeat Rate	2:0	000: 12.5ms (ALS will be disabled automatically) 001: 50ms 010: 70ms 011: 100ms (default) 100: 200ms 101: 500ms 110: 1000ms 111: 2000ms

## Optical Sensor LTR-507ALS-01

### 6.6. ALS\_MEAS\_RATE Register (0x85)

The ALS\_MEAS\_RATE register controls the ALS ADC resolution (bit width) and ALS Measurement Repeat Rate. The integration time is depends on selected ADC bit width. ALS Measurement Repeat Rate is the interval between ALS\_DATA registers update.

ALS Measurement Repeat Rate must be larger than the ALS Integration Time. If ALS Measurement Repeat Rate is set to be smaller than ALS Integration Time, it will automatically be reset to be larger than ALS Integration Time by the IC internally.

0x85	ALS_MEAS_RATE (default = 0x82)							
	Bit 7	Bit 6	Bit 5	Bit 4	Bit 3	Bit 2	Bit 1	Bit 0
	ADC Resolution / Bit Width			Reserved		ALS Measurement Repeat Rate		

Field	BITS	Description
ADC Resolution / Bit Width	7:5	000: 20 bit (Integration Time = 1200ms) 001: 19 bit (Integration Time = 600ms) 010: 18 bit (Integration Time = 300ms) 011: 17 bit (Integration Time = 150ms) 100: 16 bit (Integration Time = 75ms) (default) 101: 12 bit (Integration Time = 4.685ms) 110: 8 bit (Integration Time = 292us) 111: 4 bit (Integration Time = 18us)
Reserved	4:3	Must write as 0
ALS Measurement Repeat Rate	2:0	000: 100ms 001: 200ms 010: 500ms (default) 011: 1000ms Others: 2000ms

### 6.7. PART\_ID Register (0x86) (Read Only)

The PART\_ID register defines the part number and revision identification of the sensor.

0x86	PART_ID (default = 0x91)							
	Bit 7	Bit 6	Bit 5	Bit 4	Bit 3	Bit 2	Bit 1	Bit 0
	Part Number ID				Revision ID			

Field	BITS	Description
Part Number ID	7:4	0x09H
Revision ID	3:0	0x01H

### 6.8. MANUFAC\_ID Register (0x87) (Read Only)

The MANUFAC\_ID register defines the manufacturer identification of the sensor.

0x87	MANUFAC_ID (default = 0x05)							
	Bit 7	Bit 6	Bit 5	Bit 4	Bit 3	Bit 2	Bit 1	Bit 0
	<i>Manufacturer ID</i>							

Field	BITS	Description
Manufacturer ID	7:0	0x05H

### 6.9. ALS\_DATA Register (0x88 / 0x89) (Read Only)

The final ALS converted lux data are expressed as a 16-bit data spread over two registers. The ALS\_DATA\_0 and ALS\_DATA\_1 registers provide the lower and upper byte respectively. This 16-bit data equals to illuminance in lux. When the I2C read operation starts, both the registers are locked until the I2C read operation is completed. This will ensure that the data in the registers is from the same measurement even if an additional integration cycle ends during the read operation. New measurement data is stored into temporary registers and the ALS\_DATA registers are updated as soon as there is no on-going I2C read operation.

0x88	ALS_DATA_0 (default = 0x00)							
	Bit 7	Bit 6	Bit 5	Bit 4	Bit 3	Bit 2	Bit 1	Bit 0
	<i>LS Data Low</i>							

0x89	ALS_DATA_1 (default = 0x00)							
	Bit 7	Bit 6	Bit 5	Bit 4	Bit 3	Bit 2	Bit 1	Bit 0
	<i>LS Data High</i>							

Field	Addr	BITS	Description
ALS Data Low	0x88	7:0	ALS ADC lower byte data
ALS Data High	0x89	7:0	ALS ADC upper byte data

### 6.10. ALS\_PS\_STATUS Register (0x8A) (Read Only)

The ALS\_PS\_STATUS register stores the information about interrupt status and ALS and PS data status. New data means data has not been read yet. When the measurement is completed and data is written to the data register, the data status bit will be set to logic 1. When the ALS\_PS\_STATUS register is read, the data status bit will be set to logic 0.

Interrupt status determines if the ALS and PS interrupt criteria are met. It will check if the ALS or PS measurement data is outside of the range defined by the upper and lower threshold limits.

0x8A	ALS_PS_STATUS (default = 0x00)							
	Bit 7	Bit 6	Bit 5	Bit 4	Bit 3	Bit 2	Bit 1	Bit 0
	<i>Reserved</i>		<i>Interrupt Source</i>		<i>ALS Interrupt Status</i>	<i>ALS Data Status</i>	<i>PS Interrupt Status</i>	<i>PS Data Status</i>

Field	BITS	Description
Reserved	7:6	Do not care
Interrupt Source	5:4	00: No interrupt event 01: Interrupt is triggered by PS 10: Interrupt is triggered by ALS 11: Reserved
ALS Interrupt Status	3	0: ALS interrupt is clear or not yet triggered 1: ALS interrupt is triggered
ALS Data Status	2	0: ALS measurement data is old data (Data has been read) 1: ALS measurement data is new data (Data has not been read)
PS Interrupt Status	1	0: PS interrupt is clear or not yet triggered 1: PS interrupt is triggered
PS Data Status	0	0: PS measurement data is old data (Data has been read) 1: PS measurement data is new data (Data has not been read)

### 6.11. PS\_DATA\_0 Register (0x8B / 0x8C) (Read Only)

The PS ADC channel data are expressed as a 11-bit data spread over two registers. The PS\_DATA\_0 and PS\_DATA\_1 registers provide the lower and upper byte respectively. When the I2C read operation starts, both the registers are locked

## Optical Sensor LTR-507ALS-01

until the I2C read operation is completed. This will ensure that the data in the registers is from the same measurement even if an additional integration cycle ends during the read operation. New measurement data is stored into temporary registers and the PS\_DATA registers are updated as soon as there is no on-going I2C read operation.

0x8B	PS_DATA_0 (default = 0x00)							
	Bit 7	Bit 6	Bit 5	Bit 4	Bit 3	Bit 2	Bit 1	Bit 0
	<i>PS Data Low</i>							

0x8C	PS_DATA_1 (default = 0x00)							
	Bit 7	Bit 6	Bit 5	Bit 4	Bit 3	Bit 2	Bit 1	Bit 0
	<i>Reserved</i>			<i>Valid</i>	<i>Reserved</i>		<i>PS Data High</i>	

Field	Addr	BITS	Description
PS Data Low	0x8B	7:0	PS ADC lower byte data
Reserved	0x8C	7:5	Do not care
Valid	0x8C	4	0: Valid PS data 1: Overflow PS data
Reserved	0x8C	3	Do not care
PS Data High	0x8C	2:0	PS ADC upper byte data

### 6.12. ALS\_DATA\_CH1 Register (0x8D / 0x8E / 0x8F) (Read Only)

The ALS ADC channel 1 data is the 4...20 bit ADC output data of the clear diode. The data format is MSB aligned depending on the programmed ADC resolution. When the I2C read operation starts, both the registers are locked until the I2C read operation is completed. This will ensure that the data in the registers is from the same measurement even if an additional integration cycle ends during the read operation. New measurement data is stored into temporary registers and the ALS\_DATA registers are updated as soon as there is no on-going I2C read operation.

0x8D	ALS_DATA_CH1_0 (default = 0x00)							
	Bit 7	Bit 6	Bit 5	Bit 4	Bit 3	Bit 2	Bit 1	Bit 0
	<i>ALS Data Ch1_0</i>				<i>Reserved</i>			

0x8E	ALS_DATA_CH1_1 (default = 0x00)							
	Bit 7	Bit 6	Bit 5	Bit 4	Bit 3	Bit 2	Bit 1	Bit 0
	<i>ALS Data Ch1_1</i>							
0x8F	ALS_DATA_CH1_2 (default = 0x00)							
	Bit 7	Bit 6	Bit 5	Bit 4	Bit 3	Bit 2	Bit 1	Bit 0
	<i>ALS Data Ch1_2</i>							

Field	Addr	BITS	Description
ALS Data Ch1_0	0x8D	7:4	ALS ADC channel 1 data least significant data byte, bit 4 is the LSB of the 20-bit data
ALS Data Ch1_0	0x8D	3:0	Do not care
ALS Data Ch1_1	0x8E	7:0	ALS ADC channel 1 data mid significant data byte
ALS Data Ch1_2	0x8F	7:0	ALS ADC channel 1 data most significant data byte, bit 7 is MSB of the 20-bit data

### 6.13. ALS\_DATA\_CH2 Register (0x90 / 0x91 / 0x92) (Read Only)

The ALS ADC channel 2 data is the 4...20 bit ADC output data of the IR diode. The data format is MSB aligned depending on the programmed ALS resolution. When the I2C read operation starts, both the registers are locked until the I2C read operation is completed. This will ensure that the data in the registers is from the same measurement even if an additional integration cycle ends during the read operation. New measurement data is stored into temporary registers and the ALS\_DATA registers are updated as soon as there is no on-going I2C read operation.

0x90	ALS_DATA_CH2_0 (default = 0x00)							
	Bit 7	Bit 6	Bit 5	Bit 4	Bit 3	Bit 2	Bit 1	Bit 0
	<i>ALS Data Ch2_0</i>				<i>Reserved</i>			

0x91	ALS_DATA_CH2_1 (default = 0x00)							
	Bit 7	Bit 6	Bit 5	Bit 4	Bit 3	Bit 2	Bit 1	Bit 0
	<i>ALS Data Ch2_1</i>							



0x92	ALS_DATA_CH2_2 (default = 0x00)							
	Bit 7	Bit 6	Bit 5	Bit 4	Bit 3	Bit 2	Bit 1	Bit 0
	ALS Data Ch2_2							

Field	Addr	BITS	Description
ALS Data Ch2_0	0x90	7:4	ALS ADC channel 2 data least significant data byte, bit 4 is the LSB of the 20-bit data
ALS Data Ch2_0	0x90	3:0	Do not care
ALS Data Ch2_1	0x91	7:0	ALS ADC channel 2 data mid significant data byte
ALS Data Ch2_2	0x92	7:0	ALS ADC channel 2 data most significant data byte, bit 7 is MSB of the 20-bit data

### 6.14. ALS\_COEFF1 Register (0x93 / 0x94)

The ALS\_COEFF1 is the 16-bit coefficient for the Ch1 diode to calculate the illuminance in lux. When the I2C read operation starts, both the registers are locked until the I2C read operation is completed. This will ensure that the data in the registers is from the same measurement even if an additional integration cycle ends during the read operation. New measurement data is stored into temporary registers and the ALS\_COEFF1 registers are updated as soon as there is no on-going I2C read operation.

0x93	ALS_COEFF1_0 (default = 0x80)							
	Bit 7	Bit 6	Bit 5	Bit 4	Bit 3	Bit 2	Bit 1	Bit 0
	ALS Coeff1_0							

0x94	ALS_COEFF1_1 (default = 0x03)							
	Bit 7	Bit 6	Bit 5	Bit 4	Bit 3	Bit 2	Bit 1	Bit 0
	ALS Coeff1_1							

Field	Addr	BITS	Description
ALS COEFF1_0	0x93	7:0	ALS coefficient 1 data least significant data byte, bit 0 is the LSB of the 16-bit data
ALS COEFF1_1	0x94	7:0	ALS coefficient 1 data most significant data byte, bit 7 is MSB of the 16-bit data

### 6.15. ALS\_COEFF2 Register (0x95 / 0x96)

The ALS\_COEFF2 is the 16-bit coefficient for the Ch2 diode to calculate the illuminance in lux. These coefficients are programmable to be optimized for different input filters and light spectra. When the I2C read operation starts, both the registers are locked until the I2C read operation is completed. This will ensure that the data in the registers is from the same measurement even if an additional integration cycle ends during the read operation. New measurement data is stored into temporary registers and the ALS\_COEFF2 registers are updated as soon as there is no on-going I2C read operation.

0x95	ALS_COEFF2_0 (default = 0xC8)							
	Bit 7	Bit 6	Bit 5	Bit 4	Bit 3	Bit 2	Bit 1	Bit 0
	<i>ALS Coeff2_0</i>							

0x96	ALS_COEFF2_1 (default = 0xFB)							
	Bit 7	Bit 6	Bit 5	Bit 4	Bit 3	Bit 2	Bit 1	Bit 0
	<i>ALS Coeff2_1</i>							

Field	Addr	BITS	Description
ALS COEFF2_0	0x95	7:0	ALS coefficient 2 data least significant data byte, bit 0 is the LSB of the 16-bit data
ALS COEFF2_1	0x96	7:0	ALS coefficient 2 data most significant data byte, bit 7 is MSB of the 16-bit data

### 6.16. ALS\_IRF\_CUT\_OFF Register (0x97)

The ALS\_IRF\_CUT\_OFF is the ALS cut off limit of IR factor. When the IR factor exceeds the cut-off limit, the output value will be logic '0'. This limit is also adjustable.

0x97	ALS_IRF_CUT_OFF (default = 0xD0)							
	Bit 7	Bit 6	Bit 5	Bit 4	Bit 3	Bit 2	Bit 1	Bit 0
	<i>ALS IRF Cut Off</i>							

Field	Addr	BITS	Description
ALS IRF Cut Off	0x97	7:0	If ADCIR / ADCCLEAR > ALS IRF Cut Off, ALS_DATA = 0

### 6.17. INTERRUPT Register (0x98)

The INTERRUPT register controls the operation of the interrupt pin and functions. When the Interrupt Mode is set to 00, the INT output pin 2 is inactive / disabled and will not trigger any interrupt. However at this condition, the ALS\_PS\_STATUS register will still be updated.

0x98	INTERRUPT (default = 0x08)							
	Bit 7	Bit 6	Bit 5	Bit 4	Bit 3	Bit 2	Bit 1	Bit 0
	Reserved				Output Mode	Interrupt Polarity	Interrupt Mode	

Field	BITS	Description
Reserved	7:4	Must write as 0
Output Mode	3	0: INT output pin 2 is latched and kept in triggered state until ALS_PS_STATUS register is read 1: INT output pin 2 is updated after every measurement (default)
Interrupt Polarity	2	0: INT output pin 2 is considered active when it is a logic 0 (default) 1: INT output pin 2 is considered active when it is a logic 1
Interrupt Mode	1:0	00: INT output pin 2 is inactive / high impedance state (default) 01: Only PS measurement can trigger interrupt 10: Only ALS measurement can trigger interrupt 11: Both ALS and PS measurement can trigger interrupt

### 6.18. PS\_THRES Register (0x99 / 0x9A / 0x9B / 0x9C)

The PS\_THRES\_UP and PS\_THRES\_LOW registers determines the upper and lower limit of the interrupt threshold value respectively. These two values form a range and the interrupt function compares if the measurement value in PS\_DATA registers is inside or outside the range. The interrupt function is active if the measurement data is outside the range defined by the upper and lower limits. The data format for PS\_THRES must be the same as PS\_DATA registers.

0x99	PS_THRES_UP_0 (default = 0xFF)							
	Bit 7	Bit 6	Bit 5	Bit 4	Bit 3	Bit 2	Bit 1	Bit 0
	PS Upper Threshold Low							

## Optical Sensor LTR-507ALS-01

0x9A	PS_THRES_UP_1 (default = 0x07)							
	Bit 7	Bit 6	Bit 5	Bit 4	Bit 3	Bit 2	Bit 1	Bit 0
	<i>Reserved</i>					<i>PS Upper Threshold High</i>		

**PS\_THRES\_LOW** is a 16-bit lower threshold limits made up of two 8 bits register as shown below.

0x9B	PS_THRES_LOW_0 (default = 0x00)							
	Bit 7	Bit 6	Bit 5	Bit 4	Bit 3	Bit 2	Bit 1	Bit 0
	<i>PS Lower Threshold Low</i>							

0x9C	PS_THRES_LOW_1 (default = 0x00)							
	Bit 7	Bit 6	Bit 5	Bit 4	Bit 3	Bit 2	Bit 1	Bit 0
	<i>Reserved</i>					<i>PS Lower Threshold High</i>		

Field	Addr	BITS	Description
PS Upper Threshold Low	0x99	7:0	PS upper threshold lower byte
Reserved	0x9A	7:3	Do not care
PS Upper Threshold High	0x9A	2:0	PS upper threshold upper byte
PS Lower Threshold Low	0x9B	7:0	PS lower threshold lower byte
Reserved	0x9C	7:3	Do not care
PS Lower Threshold High	0x9C	2:0	PS lower threshold upper byte

### 6.19. ALS\_THRES Register (0x9E / 0x9F / 0xA0 / 0xA1)

The ALS\_THRES\_UP and ALS\_THRES\_LOW registers determines the upper and lower limit of the interrupt threshold value respectively. These two values form a range and the interrupt function compares if the measurement value in ALS\_DATA registers is inside or outside the range. The interrupt function is active if the measurement data is outside the range defined by the upper and lower limits. The data format for ALS\_THRES must be the same as ALS\_DATA registers.

## Optical Sensor LTR-507ALS-01

0x9E	ALS_THRES_UP_0 (default = 0xFF)							
	Bit 7	Bit 6	Bit 5	Bit 4	Bit 3	Bit 2	Bit 1	Bit 0
	<i>ALS Upper Threshold Low</i>							

0x9F	ALS_THRES_UP_1 (default = 0xFF)							
	Bit 7	Bit 6	Bit 5	Bit 4	Bit 3	Bit 2	Bit 1	Bit 0
	<i>ALS Upper Threshold High</i>							

**ALS\_THRES\_LOW** is a 16-bit lower threshold limits made up of two 8 bits register as shown below.

0xA0	ALS_THRES_LOW_0 (default = 0x00)							
	Bit 7	Bit 6	Bit 5	Bit 4	Bit 3	Bit 2	Bit 1	Bit 0
	<i>ALS Lower Threshold Low</i>							
0xA1	ALS_THRES_LOW_1 (default = 0x00)							
	Bit 7	Bit 6	Bit 5	Bit 4	Bit 3	Bit 2	Bit 1	Bit 0
	<i>ALS Lower Threshold High</i>							

Field	Addr	BITS	Description
ALS Upper Threshold Low	0x9E	7:0	ALS upper threshold lower byte
ALS Upper Threshold High	0x9F	7:0	ALS upper threshold upper byte
ALS Lower Threshold Low	0xA0	7:0	ALS lower threshold lower byte
ALS Lower Threshold High	0xA1	7:0	ALS lower threshold upper byte

### 6.20. INTERRUPT PERSIST Register (0xA4)

The INTERRUPT PERSIST register controls the N number of times the measurement data is outside the range defined by the upper and lower threshold limits before asserting the INT output pin 2.

## Optical Sensor LTR-507ALS-01

0xA4	INTERRUPT PERSIST (default = 0x00)							
	Bit 7	Bit 6	Bit 5	Bit 4	Bit 3	Bit 2	Bit 1	Bit 0
	<i>PS Persist</i>				<i>ALS Persist</i>			

Field	BITS	Description
PS Persist	7:4	0000: Every PS measurement data will generate an interrupt (default) 0001: 1 consecutive PS measurement data outside the range 0010: 2 consecutive PS measurement data outside the range ... 1111: 15 consecutive PS measurement data outside the range
ALS Persist	3:0	0000: Every ALS measurement data will generate an interrupt (default) 0001: 1 consecutive ALS measurement data outside the range 0010: 2 consecutive ALS measurement data outside the range ... 1111: 15 consecutive ALS measurement data outside the range

### 7. Pseudo Codes Examples

#### PS LED Registers

// The PS LED Registers define the LED pulse modulation frequency and peak current.  
// Default setting is 0x6B (60kHz, 50mA).

Slave\_Addr = 0x23

// Slave address of LTR-507 device

#### // Set LED Pulse Freq 30kHz (with default peak curr 50mA)

Register\_Addr = 0x82  
Command = 0x0B

// PS\_LED register  
// For Pulse Freq = 30kHz  
// For Pulse Freq = 40kHz, Command = 0x2B  
// For Pulse Freq = 50kHz, Command = 0x4B  
// For Pulse Freq = 60kHz, Command = 0x6B  
// For Pulse Freq = 70kHz, Command = 0x8B  
// For Pulse Freq = 80kHz, Command = 0xAB  
// For Pulse Freq = 90kHz, Command = 0xCB  
// For Pulse Freq = 100kHz, Command = 0xEB

WriteByte(Slave\_Addr, Register\_Addr, Command)

#### // Set LED Peak Current 5mA (with default pulse freq 60kHz)

Register\_Addr = 0x82  
Command = 0x68

// PS\_LED register  
// Peak Current = 5mA  
// For Peak Current = 10mA, Command = 0x69  
// For Peak Current = 20mA, Command = 0x6A  
// For Peak Current = 50mA, Command = 0x6B  
// For Peak Current = 100mA, Command = 0x6C, 0x6D, 0x6E, 0x6F

WriteByte(Slave\_Addr, Register\_Addr, Command)

#### PS\_N\_Pulses Register

// The PS\_N\_Pulses Registers controls the number of LED pulses to be emitted.  
// Default setting is 0x7F (127pulses).

Slave\_Addr = 0x23

// Slave address of LTR-507 device

#### // Set LED Pulses to 64 Pulses

Register\_Addr = 0x83  
Command = 0x40

// PS\_N\_Pulses register  
// For PS pulses = 64,  
// For PS pulses = 0, Command = 0x00  
// For PS pulses = 1, Command = 0x01  
// For PS pulses = 2, Command = 0x02  
// .....  
// For PS pulses = 254, Command = 0xFE  
// For PS pulses = 255, Command = 0xFF

WriteByte(Slave\_Addr, Register\_Addr, Command)

#### PS Measurement Rate

// The PS\_MEAS\_RATE register controls the PS measurement rate which define the interval between PS\_DATA update.  
// Default setting of the register is 0x03 (Repeat rate 100ms)

Slave\_Addr = 0x23

// Slave address of LTR-507 device

#### // Set PS Repeat Rate 12.5ms

Register\_Addr = 0x84  
Command = 0x00

// PS\_MEAS\_RATE register  
// Meas rate = 12.5ms  
// For Meas rate = 50ms, Command = 0x01  
// For Meas rate = 70ms, Command = 0x02  
// For Meas rate = 100ms, Command = 0x03  
// For Meas rate = 200ms, Command = 0x04  
// For Meas rate = 500ms, Command = 0x05

## Optical Sensor LTR-507ALS-01

// For Meas rate = 1000ms, Command = 0x06  
// For Meas rate = 2000ms, Command = 0x07

WriteByte(Slave\_Addr, Register\_Addr, Command)

### ALS Measurement Rate

// The ALS\_MEAS\_RATE register controls the ALS ADC resolution (bit width) and ALS measurement rate.  
// Default setting of the register is 0x82 (Bit width 16bit, repeat rate 500ms)

Slave\_Addr = 0x23 // Slave address of LTR-507 device

#### // Set ALS ADC Resolution 20bits (with default repeat rate 500ms)

Register\_Addr = 0x85 // ALS\_MEAS\_RATE register  
Command = 0x02 // Bit width = 20bit,  
// Bit width = 19bit, Command = 0x22  
// Bit width = 18bit, Command = 0x42  
// Bit width = 17bit, Command = 0x62  
// Bit width = 16bit, Command = 0x82  
// Bit width = 12bit, Command = 0xA2  
// Bit width = 8bit, Command = 0xC2  
// Bit width = 4bit, Command = 0xE2

WriteByte(Slave\_Addr, Register\_Addr, Command)

#### // Set ALS Repeat Rate 100ms (with default bit width 16bit)

Register\_Addr = 0x85 // ALS\_MEAS\_RATE register  
Command = 0x80 // Meas rate = 100ms  
// Meas rate = 200ms, Command = 0x81  
// Meas rate = 500ms, Command = 0x82  
// Meas rate = 1000ms, Command = 0x83  
// Meas rate = 2000ms, Command = 0x84, 0x85, 0x86, 0x87

WriteByte(Slave\_Addr, Register\_Addr, Command)

### Interrupt Registers

// The Interrupt register controls the operation of the interrupt pins and function.  
// The default value for this register is 0x08 (Interrupt inactive)

Slave\_Addr = 0x23 // Slave address of LTR-507 device

#### // Set Interrupt to Active (with active low polarity and output pin2 will be updated after every measurement)

Register\_Addr = 0x98 // Interrupt Register address  
Command = 0x0B // Both ALS and PS can trigger,  
// Only PS trigger, Command = 0x07  
// Only ALS trigger, Command = 0x06

WriteByte(Slave\_Addr, Register\_Addr, Command)

#### // Set Interrupt Output Mode (with both ALS and PS triggered and with active low polarity)

Register\_Addr = 0x98 // Interrupt Register address  
Command = 0x03 // Output pin2 is latched and kept triggered until ALS\_PS\_STATUS  
register is read  
// For output pin2 is updated after every measurement,  
Command = 0x0B

WriteByte(Slave\_Addr, Register\_Addr, Command)

#### // Set Interrupt Polarity to Active High // (with both ALS and PS triggered and output pin2 is updated after every measurement)

Register\_Addr = 0x98 // Interrupt Register address  
Command = 0x0F // Output pin2 is active high,  
// For Output pin2 is active low, Command = 0x0B

WriteByte(Slave\_Addr, Register\_Addr, Command)



## Optical Sensor LTR-507ALS-01

### PS Threshold Registers

// The PS\_THRES\_UP and PS\_THRES\_LOW registers determines the upper and lower limit of the interrupt threshold // value.  
// Following example illustrates the setting of the PS threshold window of decimal values of 200 (lower threshold) and // 1000 (upper threshold).

```
Slave_Addr = 0x23 // Slave address of LTR-559 device

// Upper Threshold Setting (decimal 1000)
PS_THRES_UP_0 = 0x99 // PS Upper Threshold Low Byte Register address
PS_THRES_UP_1 = 0x9A // PS Upper Threshold High Byte Register address
Data1 = 1000 >> 8 // To convert decimal 1000 into two eight bytes register values
Data0 = 1000 & 0xFF
WriteByte(Slave_Addr, PS_Upp_Threshold_Reg_0, Data0)
WriteByte(Slave_Addr, PS_Upp_Threshold_Reg_1, Data1)

// Lower Threshold Setting (decimal 200)
PS_THRES_LOW_0 = 0x9B // PS Lower Threshold Low Byte Register address
PS_THRES_LOW_1 = 0x9C // PS Lower Threshold High Byte Register address
Data1 = 200 >> 8 // To convert decimal 200 into two eight bytes register values
Data0 = 200 & 0xFF
WriteByte(Slave_Addr, PS_Low_Threshold_Reg_0, Data0)
WriteByte(Slave_Addr, PS_Low_Threshold_Reg_1, Data1)
```

### ALS Threshold Registers

// The ALS\_THRES\_UP and ALS\_THRES\_LOW registers determines the upper and lower limit of the interrupt threshold // value.  
// Following example illustrates the setting of the ALS threshold window of decimal values of 200 (lower threshold) and // 1000 (upper threshold).

```
Slave_Addr = 0x23 // Slave address of LTR-507 device

// Upper Threshold Setting (decimal 1000)
ALS_THRES_UP_0 = 0x9E // ALS Upper Threshold Low Byte Register address
ALS_THRES_UP_1 = 0x9F // ALS Upper Threshold High Byte Register address
Data1 = 1000 >> 8 //To convert decimal 1000 into two eight bytes register values
Data0 = 1000 & 0xFF
WriteByte(Slave_Addr, ALS_THRES_UP_0, Data0)
WriteByte(Slave_Addr, ALS_THRES_UP_1, Data1)

// Lower Threshold Setting (decimal 200)
ALS_THRES_LOW_0 = 0xA0 // ALS Lower Threshold Low Byte Register address
ALS_THRES_LOW_1 = 0xA1 // ALS Lower Threshold High Byte Register address
Data1 = 200 >> 8 //To convert decimal 200 into two eight bytes register values
Data0 = 200 & 0xFF
WriteByte(Slave_Addr, ALS_THRES_LOW_0, Data0)
WriteByte(Slave_Addr, ALS_THRES_LOW_1, Data1)
```

### Interrupt Persist Register

// The INTERRUPT PERSIST register controls the N number of times the measurement data is out of the threshold range // for both ALS and PS before asserting the INT output pin 2.  
// The default setting is 0x00 (Every PS and/or ALS measurement data will generate an interrupt).

```
Slave_Addr = 0x23 // Slave address of LTR-507 device

// Set PS Persist 5 (with ALS persist 0)
Register_Addr = 0xA4 // INTERRUPT PERSIST register
Command = 0x50 // PS persist = 5
```

## Optical Sensor LTR-507ALS-01

```
// For PS persist = 0, Command = 0x00
// For PS persist = 1, Command = 0x10
// For PS persist = 2, Command = 0x20
// .....
// For PS persist = 15, Command = 0xF0
```

```
WriteByte(Slave_Addr, Register_Addr, Command)
```

### // Set ALS Persist 5 (with PS persist 0)

```
Register_Addr = 0xA4
Command = 0x05
```

```
// INTERRUPT PERSIST register
// ALS persist = 5
// For ALS persist = 0, Command = 0x00
// For ALS persist = 1, Command = 0x01
// For ALS persist = 2, Command = 0x02
// .....
// For ALS persist = 15, Command = 0x0F
```

```
WriteByte(Slave_Addr, Register_Addr, Command)
```

## Control Registers

```
// The Control Registers define the operating modes and gain settings of the ALS and PS of LTR-507.
// It is recommended that Control Register for ALS (0x80) and PS (0x81) to be set at the end of the sequence.
// This is to ensure all register settings are the same for all started measurement.
// Default settings are 0x00 for ALS register and 0x0C for PS register (both in Standby mode after power up).
```

```
Slave_Addr = 0x23
```

```
// Slave address of LTR-507 device
```

### // Enable ALS

```
Register_Addr = 0x80
Command = 0x02
```

```
// ALS_CONTR register
// For Dynamic Range 1 (1 to 64klux)
// For Dynamic Range 2 (0.5 to 32klux), Command = 0x05
// For Dynamic Range 3 (0.02 to 640lux), Command = 0x10
// For Dynamic Range 4 (0.01 to 320lux), Command = 0x18
```

```
WriteByte(Slave_Addr, Register_Addr, Command)
```

### // Enable PS

```
Register_Addr = 0x81
Command = 0x0E
```

```
// PS_CONTR register
```

```
WriteByte(Slave_Addr, Register_Addr, Command)
```

## Data Registers (Read Only)

```
// The ALS and PS Data Registers contain the ADC output data.
// These registers should be read as a group, with the lower address being read first.
```

```
Slave_Addr = 0x23
```

```
// Slave address of LTR-507 device
```

### // Read ALS\_DATA

```
Register_Addr = 0x88
ReadByte(Slave_Addr, Register_Addr, Data0)
Register_Addr = 0x89
ReadByte(Slave_Addr, Register_Addr, Data1)
```

```
// ALS ADC low byte address
// ALS ADC high byte address
```

```
ALS_ADC_Data = (Data1 << 8) | Data0
```

```
// Combining lower and upper bytes to give 16-bit ALS ADC data
// (Direct conversion to illuminance in lux).
```

```
Slave_Addr = 0x23
```

```
// Slave address of LTR-507 device
```

### // Read PS\_DATA

```
Register_Addr = 0x8B
ReadByte(Slave_Addr, Register_Addr, Data0)
Register_Addr = 0x8C
ReadByte(Slave_Addr, Register_Addr, Data1)
```

```
// PS_DATA low byte address
// PS_DATA high byte address
```

## Optical Sensor LTR-507ALS-01

```
PS_ADC_Data = ((Data1 << 8) | Data0) & 07FF // Combining lower and upper bytes to give 11-bit PS data
Validity_PS_Data = Data0 & 0x08 // Validity_PS_Data = 0x00 → Valid PS data
// Validity_PS_Data = 0x08 → Overflow PS data
```

### // Read PS Data Validity Bit

```
Register_Addr = 0x8B // PS_DATA low byte address
ReadByte(Slave_Addr, Register_Addr, Data0) // Bit 4 = 0 = Valid PS data,
Validity_PS_Data = Data0 & 0x08 // Bit 4 = 1 = Overflow PS data
```

### ALS and PS Status Register (Read Only)

// The ALS\_PS\_STATUS Register contains the information on Interrupt, ALS and PS data availability status.

```
Slave_Addr = 0x23 // Slave address of LTR-507 device
```

### // Read Status Register

```
Register_Addr = 0x8A // ALS_PS_STATUS register address
ReadByte(Slave_Addr, Register_Addr, Data)
```

```
Interrupt_Source = Data & 0x30 // Interrupt_Status = 0x00 → No Interrupt
// Interrupt_Status = 0x10 → PS Interrupt
// Interrupt_Status = 0x20 → ALS Interrupt
```

```
ALS and PS Data Status = Data & 0x05 // NewData_Status = 0x00 → No New Data
// NewData_Status = 0x04 → ALS New Data
// NewData_Status = 0x01 → PS New Data
// NewData_Status = 0x05 → Both New Data
```

```
ALS and PS Interrupt_Status = Data & 0x0A // NewData_Status = 0x08 → ALS interrupt is triggered
// NewData_Status = 0x02 → PS interrupt is triggered
// NewData_Status = 0x0A → Both interrupts are triggered
```

### ALS Data Registers (Read Only)

// The ALS Data Registers contain the ADC output data for the respective channel.  
// These registers should be read as a group, with the lower address being read first.

```
Slave_Addr = 0x23 // Slave address of LTR-507 device
```

### // Read ALS\_DATA\_CH1

```
Register_Addr = 0x8D // ALS_DATA_CH1 low byte address
ReadByte(Slave_Addr, Register_Addr, Data0)
Register_Addr = 0x8E // ALS_DATA_CH1 mid byte address
ReadByte(Slave_Addr, Register_Addr, Data1)
Register_Addr = 0x8F // ALS_DATA_CH1 high byte address
ReadByte(Slave_Addr, Register_Addr, Data2)
```

```
ALS_CH1_Data = ((Data 2 << 16) | (Data1 << 8) | Data0) >> 4) // Combining low, mid, and high bytes to give 20-bit ALS CH1 data
```

### // Read ALS\_DATA\_CH2

```
Register_Addr = 0x90 // ALS_DATA_CH2 low byte address
ReadByte(Slave_Addr, Register_Addr, Data0)
Register_Addr = 0x91 // ALS_DATA_CH2 mid byte address
ReadByte(Slave_Addr, Register_Addr, Data1)
Register_Addr = 0x92 // ALS_DATA_CH2 high byte address
ReadByte(Slave_Addr, Register_Addr, Data2)
```

```
ALS_CH2_Data = ((Data 2 << 12) | (Data1 << 4) | (Data0 >> 4)) // Combining low, mid, and high bytes to give 20-bit ALS CH2 data
```

### 8. Recommended Lead-free Reflow Profile

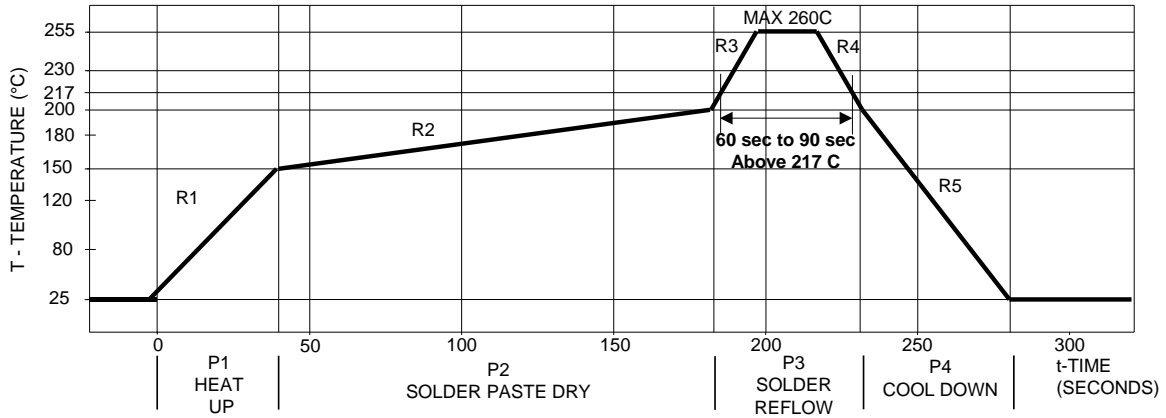

Process Zone	Symbol	$\Delta T$	Maximum $\Delta T/\Delta t$ or Duration
Heat Up	P1, R1	25°C to 150°C	3°C/s
Solder Paste Dry	P2, R2	150°C to 200°C	100s to 180s
Solder Reflow	P3, R3	200°C to 260°C	3°C/s
	P3, R4	260°C to 200°C	-6°C/s
Cool Down	P4, R5	200°C to 25°C	-6°C/s
Time maintained above liquidus point, 217°C		> 217°C	60s to 90s
Peak Temperature		260°C	-
Time within 5°C of actual Peak Temperature		> 255°C	20s
Time 25°C to Peak Temperature		25°C to 260°C	8mins

It is recommended to perform reflow soldering no more than twice.

### 9. Moisture Proof Packaging

All LTR-507ALS-01 are shipped in moisture proof package. Once opened, moisture absorption begins. This part is compliant to JEDEC J-STD-033A Level 3.

#### 9.1 Time from Unsealing to Soldering

After removal from the moisture barrier bag, the parts should be stored at the recommended storage conditions and soldered within seven days. When the moisture barrier bag is opened and the parts are exposed to the recommended storage conditions for more than seven days, the parts must be baked before reflow to prevent damage to the parts.

##### 9.1.1 Recommended Storage Conditions

<b>Storage Temperature</b>	10°C to 30°C
<b>Relative Humidity</b>	Below 60% RH

##### 9.1.2 Baking Conditions

Package	Temperature	Time
In Reels	60°C	48 hours
In Bulk	100°C	4 hours

Baking should only be done once.

10. Recommended Land Pattern and Metal Stencil Aperture

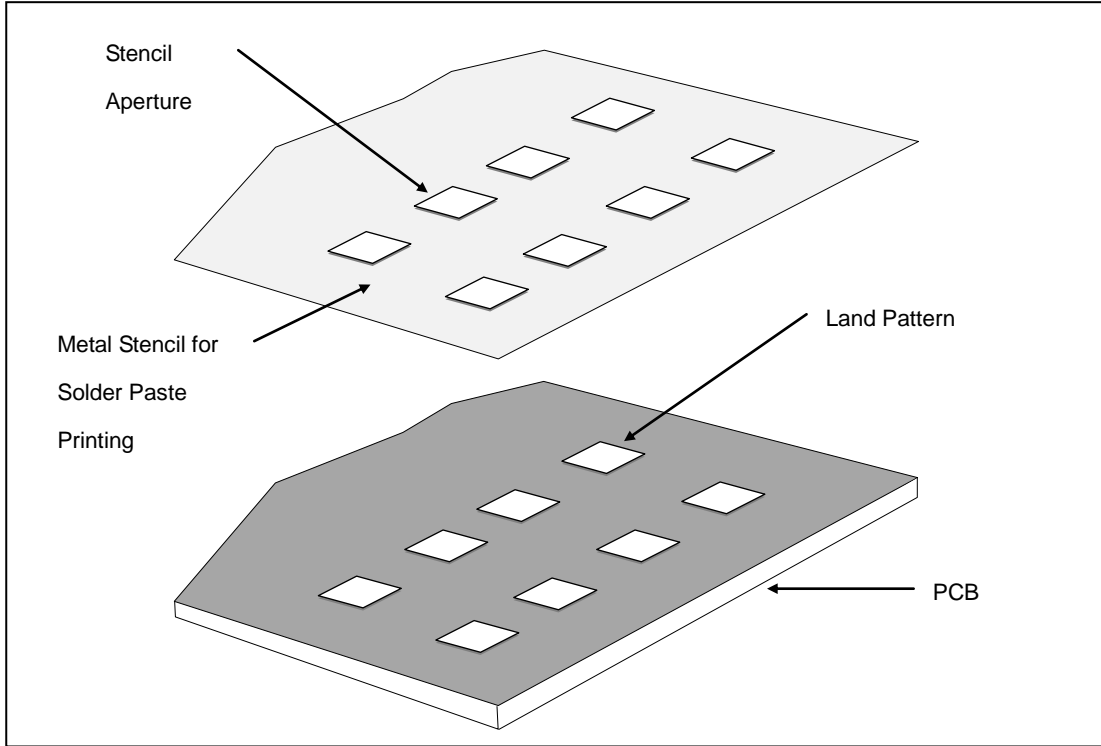

10.1 Recommended Land Pattern

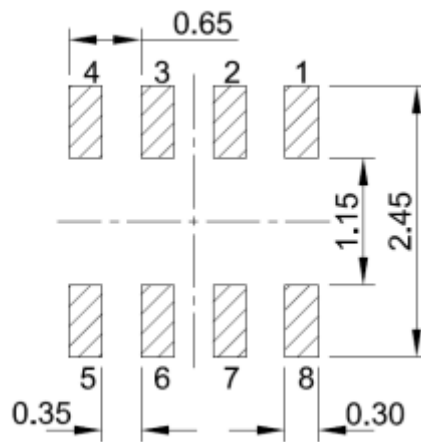

Note:

1. All dimensions are in millimeters

### 10.2 Recommended Metal Stencil Aperture

It is recommended that the metal stencil used for solder paste printing has a thickness (t) of 0.11mm (0.004 inches / 4 mils) or 0.127mm (0.005 inches / 5 mils).

The stencil aperture opening is recommended to be 0.3mm x 0.65mm which has the same dimension as the land pattern. This is to ensure adequate printed solder paste volume and yet no shorting.

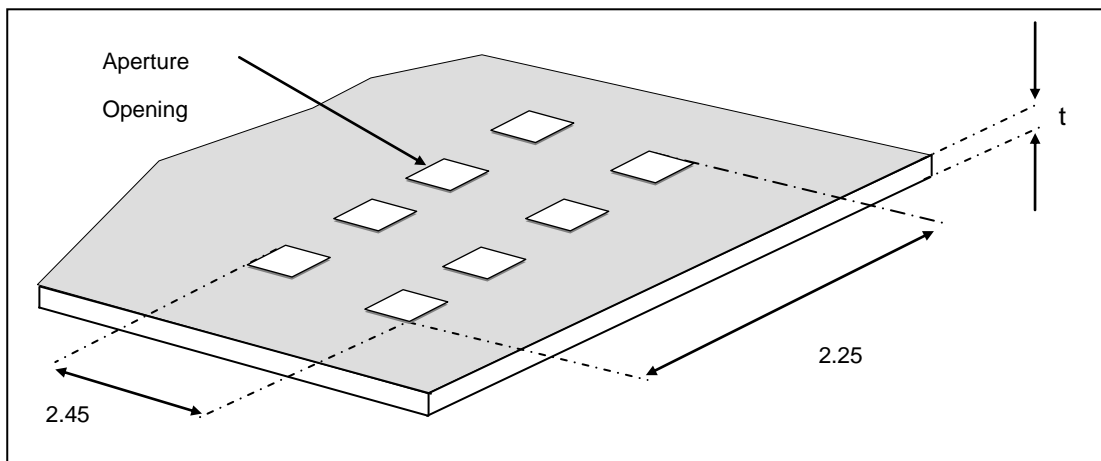

**Note:**

1. All dimensions are in millimeters

## Optical Sensor LTR-507ALS-01

### 11. Package Dimension for Tape and Reel

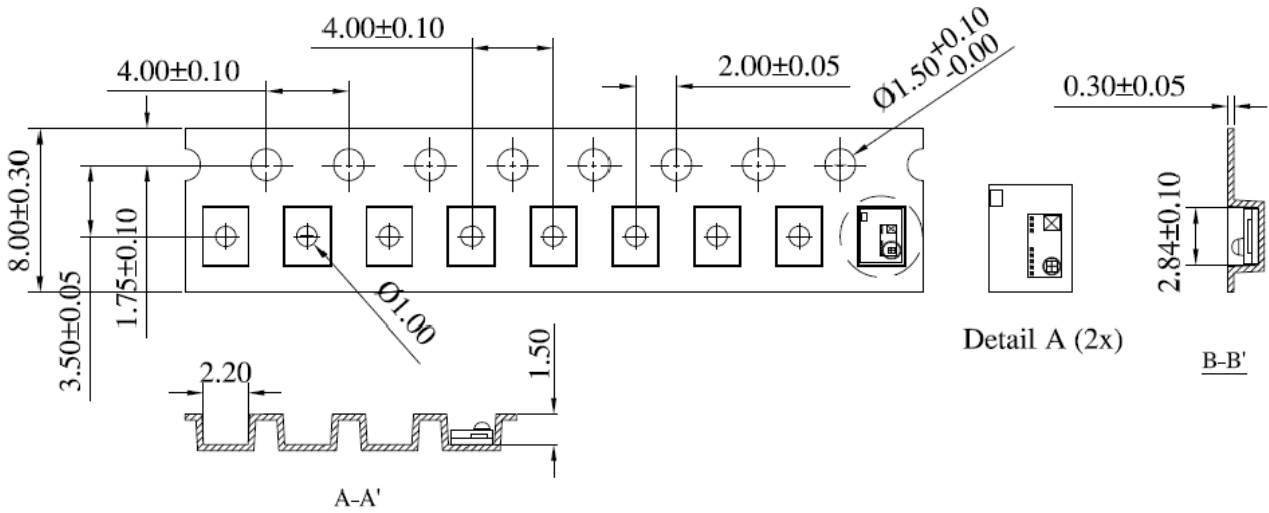

#### 11.1 Package Dimension of Reel

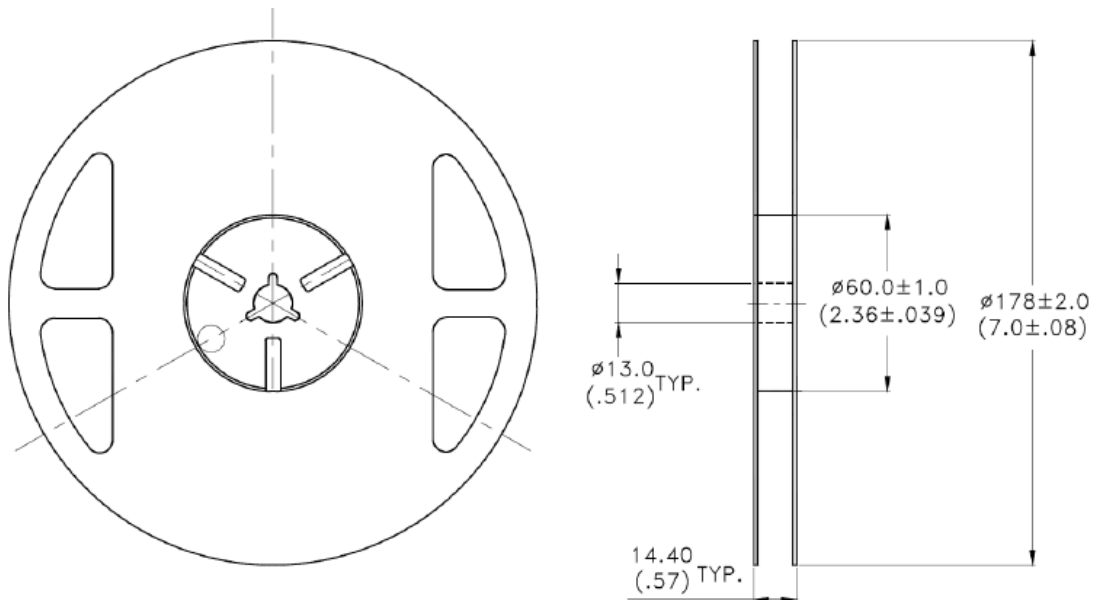

#### Notes:

1. All dimensions are in millimeters (inches)
2. Empty component pockets sealed with top cover tape
3. 7 inch reel - 2000 pieces per reel