

Power System Basis Chip with High Speed CAN transceiver

The 33907_8 devices are multi-output, power supply, integrated circuit, including HSCAN transceiver, dedicated to the automotive market.

Multiple switching and linear voltage regulators, including low power mode are available with various wake-up capabilities. An advanced power management scheme is implemented to maintain high efficiency over wide input voltages and output current ranges.

The 33907_8 includes enhanced safety features, with multiple fail-safe outputs, becoming a full part of a safety oriented system partitioning, to reach a high integrity safety level.

The built-in enhanced high speed CAN interface fulfills the ISO11898-2 and -5 standards. Local and bus failure diagnostics, protection, and fail-safe operation mode are provided. This device is powered by SMARTMOS technology.

Features

- Highly flexible SMPS pre-regulator, allowing two topologies: non-inverting buck-boost or standard buck
- Switching mode power supply (SMPS) dedicated to MCU core supply, 1.2 V or 3.3 V delivering up to 1.5 A
- Linear voltage regulator dedicated to MCU A/D reference voltage or I/Os supply (VCCA). 5.0 V or 3.3 V
- Linear voltage regulator dedicated to auxiliary functions, or to a sensor supply (VCCA tracker or independent 5.0 V / 3.3 V)
- Multiple wake-up sources in low power mode: CAN and/or IOs
- Battery voltage sensing & MUX output terminal
- Enhanced safety block associated with fail-safe outputs
- Six configurable I/Os

33907_08

POWER SYSTEM BASIS CHIP

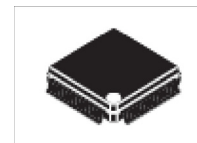

AE SUFFIX (PB-FREE)
98ASA00173D
48-PIN LQFP-EP

Applications

- Electrical power steering
- Engine management
- Battery management
- Active suspension
- Gear box
- Transmission
- Electrical Vehicle (EV), Hybrid Electrical Vehicle (HEV)
- Advanced driver assistance systems

Archive Information

Archive Information

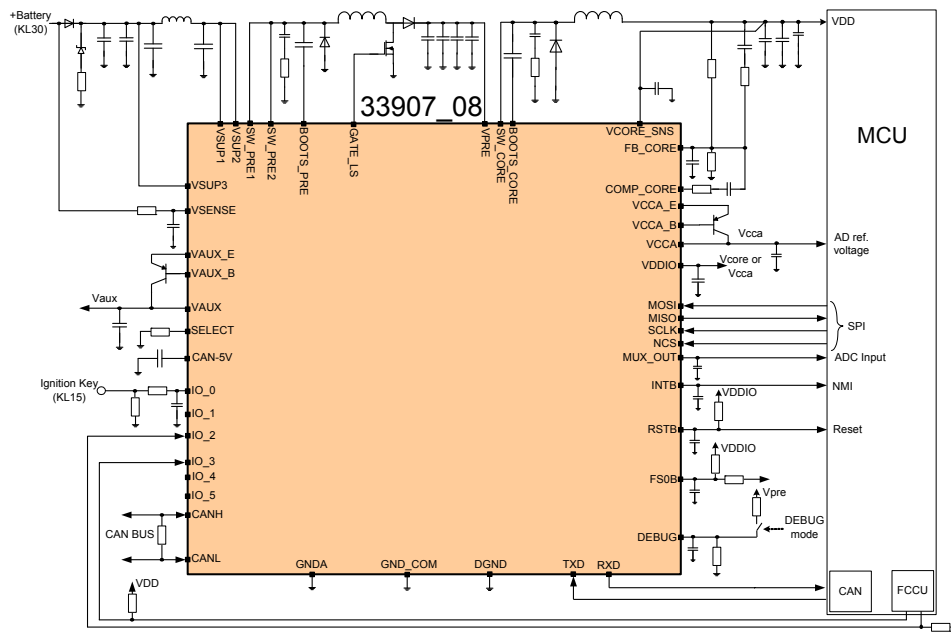

Figure 1. Simplified Application Diagram - Buck Boost Configuration

* This document contains certain information on a new product. Specifications and information herein are subject to change without notice.
© Freescale Semiconductor, Inc., 2013 - 2014. All rights reserved.

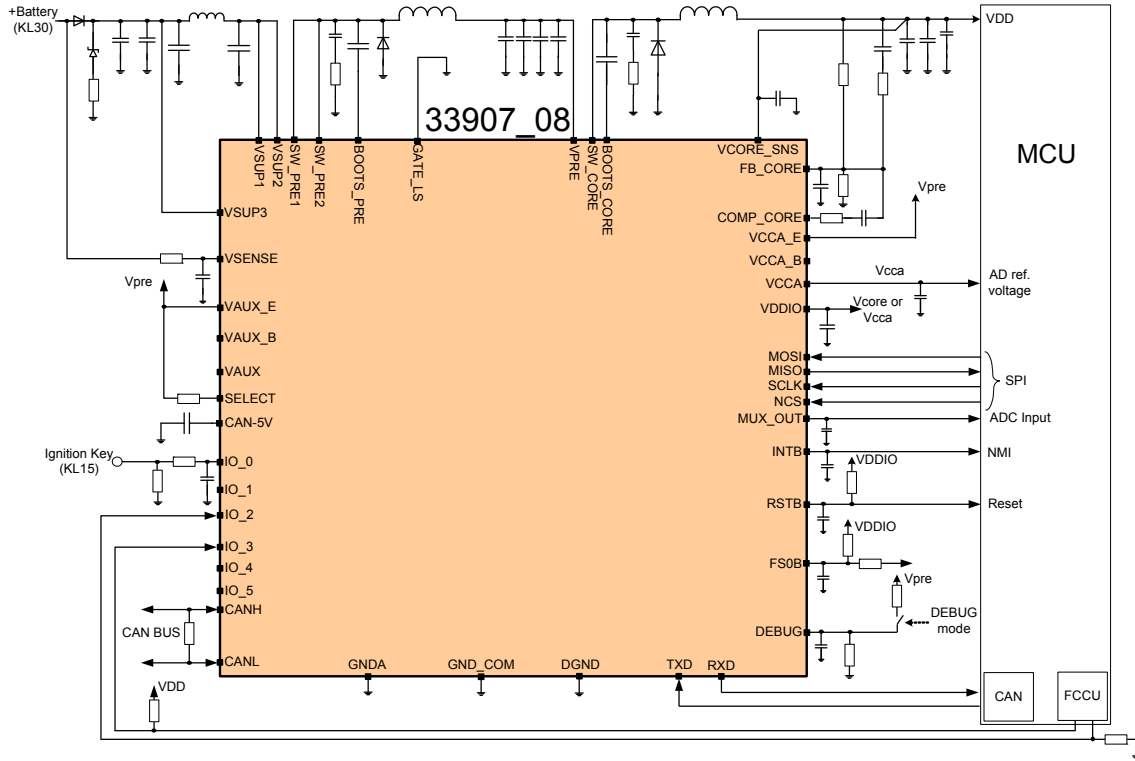

Figure 2. Simplified Application Diagram - Buck Configuration, V_{AUX} not used, $V_{CCA} = 100 \text{ mA}$

1 Orderable Parts

Table 1. Orderable Part Variations

| Part Number ⁽¹⁾ | V _{CORE} | Temperature (T _A) | Package |
|----------------------------|--|-------------------------------|-------------------------|
| MC33907AE | V _{CORE} Output Current Capability in Normal Mode Page 12 | -40 to 125 °C | 48-pin LQFP exposed pad |
| MC33908AE | | | |

Notes

1. To order parts in Tape & Reel, add the R2 suffix to the part number.

2 Internal Block Diagram

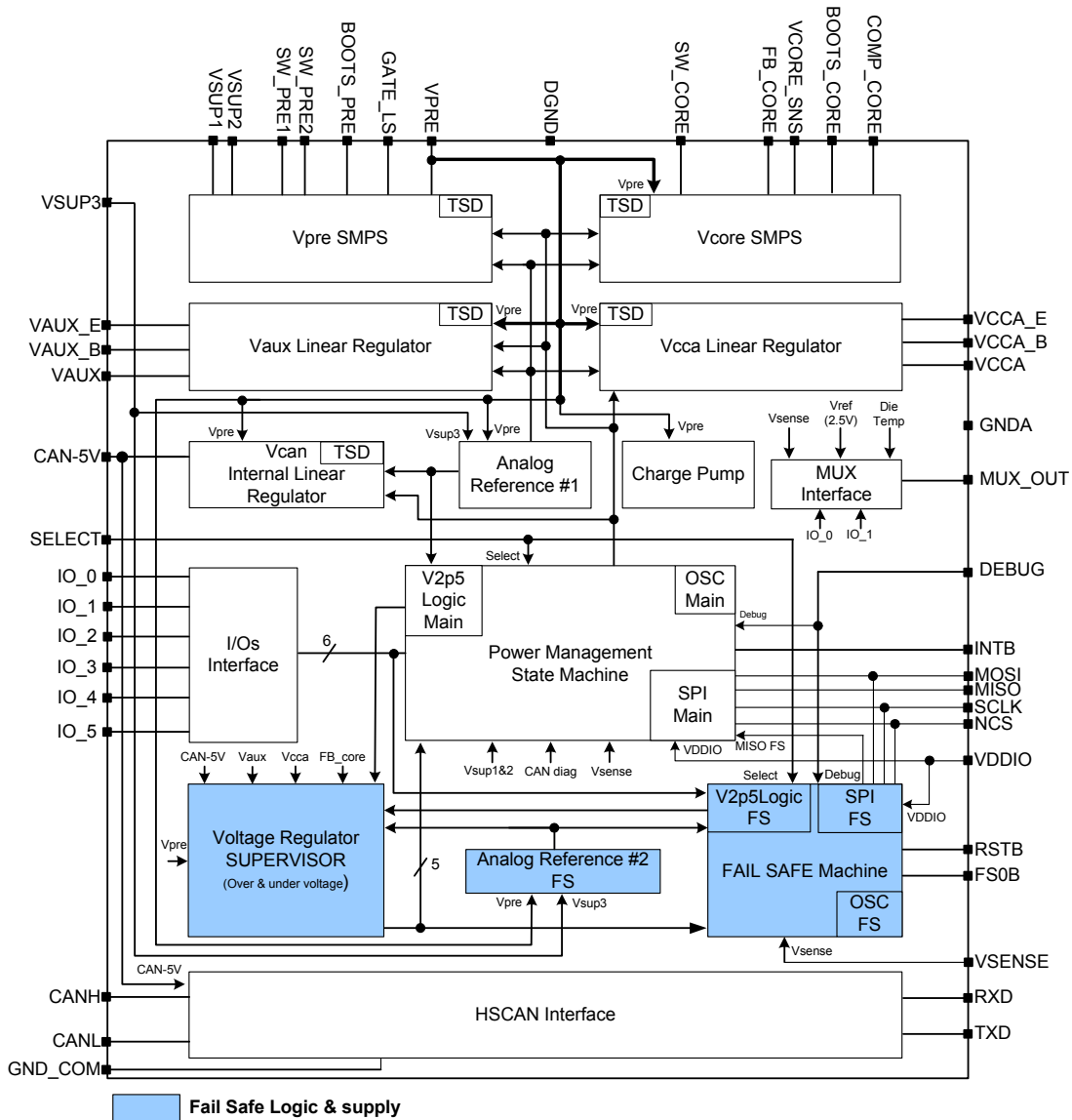

Figure 3. MC33907_08 Simplified Internal Block Diagram

Table of Contents

| | | |
|------|---|----------|
| 1 | Orderable Parts | Page 3 |
| 2 | Internal Block Diagram | Page 4 |
| 3 | Pin connections | Page 6 |
| 3.1 | Pinout Diagram for 33907_8 | Page 6 |
| 3.2 | Pin Definitions | Page 6 |
| 4 | General Product Characteristics | Page 9 |
| 4.1 | Maximum Ratings | Page 9 |
| 4.2 | Static Electrical Characteristics | Page 11 |
| 4.3 | Dynamic Electrical Characteristics | Page 20 |
| 5 | Functional Description | Page 25 |
| 5.1 | Introduction | Page 25 |
| 5.2 | Functional Pin Description | Page 25 |
| 6 | Functional Device Operation | Page 30 |
| 6.1 | Mode and State Description of MAIN State Machine | Page 30 |
| 6.2 | Mode and State Description of Fail-safe State Machine | Page 31 |
| 6.3 | Functional State Diagram | Page 33 |
| 6.4 | Fail-safe Machine | Page 34 |
| 6.5 | Fail-safe Machine State Diagram | Page 34 |
| 6.6 | Watchdog Operation | Page 35 |
| 6.7 | Wrong Watchdog Refresh Handling | Page 37 |
| 6.8 | Startup Sequence | Page 48 |
| 7 | Serial Peripheral Interface | Page 50 |
| 7.1 | High Level Overview | Page 50 |
| 7.2 | Detail Operation | Page 51 |
| 7.3 | Detail of Register Mapping | Page 55 |
| 8 | List of Interruptions and Description | Page 98 |
| 9 | Typical Applications | Page 100 |
| 10 | Packaging | Page 102 |
| 10.1 | Package Mechanical Dimensions | Page 102 |
| 11 | Revision History | Page 106 |

Archive Information

Archive Information

3 Pin connections

3.1 Pinout Diagram for 33907_8

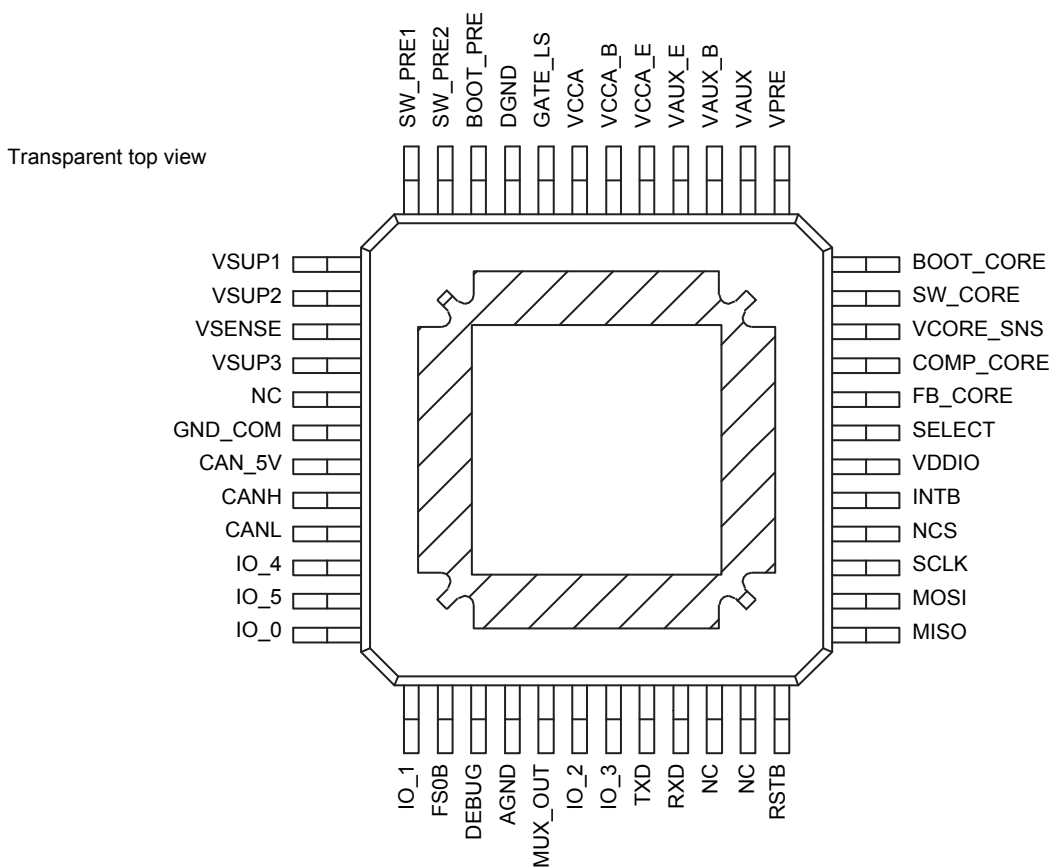

Figure 4. 33907_8 Pinout

3.2 Pin Definitions

A functional description of each pin can be found in the functional pin description section beginning on [page 25](#).

Table 2. 33907_8 Pin Definition

| Pin | Pin Name | Type | Definition |
|-----------|----------|------|---|
| 1 | VSUP1 | A_IN | Power supply of the device. An external reverse battery protection diode in series is mandatory |
| 2 | VSUP2 | A_IN | Second power supply. Also protected by the external reverse battery protection diode used for VSUP1 |
| 3 | VSENSE | A_IN | Sensing of the battery voltage. Must be connected prior to the reverse battery protection diode. |
| 4 | VSUP3 | A_IN | Third power supply dedicated to the device supply. Also protected by the external reverse battery protection diode used for VSUP1. Shall be connected between the reverse protection diode and the input PI filter. |
| 5, 22, 23 | NC | N/A | Not connected. Pins must be left open. |

Table 2. 33907_8 Pin Definition

| Pin | Pin Name | Type | Definition |
|----------|-----------|---------------|---|
| 6 | GND_COM | GROUND | Dedicated ground for CAN |
| 7 | CAN_5V | A_OUT | Output voltage for the embedded CAN interface |
| 8 | CANH | A_IN/OUT | HSCAN output High |
| 9 | CANL | A_IN/OUT | HSCAN output Low |
| 10 11 | IO_4:5 | D_IN A_OUT | Can be used as digital input (load dump proof) with wake-up capability or as an output gate driver Digital input: Pin status can be read through the SPI. Can be used to monitor error signals from another IC for safety purposes. Wake-up capability: Can be selectable to wake-up on a rising or falling edge, or on a transition Output gate driver: Can drive a logic level low side NMOS transistor. Controlled by the SPI. |
| 12 13 | IO_0:1 | A_IN D_IN | Can be used as analog or digital input (load dump proof) with wake-up capability (selectable) Analog input: Pin status can be read through the MUX output terminal Digital input: Pin status can be read through the SPI. Can be used to monitor error signals from another IC for safety purposes Wake-up capability: Can be selectable to wake-up on a rising or falling edge, or on a transition |
| 14 | FS0B | D_OUT | Output of the safety block (active low). The pin is asserted low at startup and when a fault condition is detected. Open drain structure. |
| 15 | DEBUG | D_IN | Debug mode entry input |
| 16 | AGND | GROUND | Analog ground connection |
| 17 | MUX_OUT | A_OUT | Multiplexed output to be connected to a MCU ADC. Selection of the analog parameter is available at MUX-OUT through the SPI. |
| 18 19 | IO_2:3 | D_IN | Digital input pin with wake-up capability (logic level compatible) Digital INPUT: Pin status can be read through the SPI. Can be used to monitor error signals from MCU for safety purposes. Wake-up capability: Can be selectable to wake-up on a rising or falling edge, or on a transition. |
| 20 | TXD | D_IN | Transceiver input from the MCU which controls the state of the HSCAN bus |
| 21 | RXD | D_OUT | Receiver output which reports the state of the HSCAN bus to the MCU |
| 24 | RSTB | D_OUT | This output is asserted low when the safety block reports a failure. The main function is to reset the MCU. Reset input voltage is also monitored in order to detect external reset and fault condition. Open drain structure. |
| 25 | MISO | D_OUT | SPI bus. Master Input Slave Output |
| 26 | MOSI | D_IN | SPI bus. Master Output Slave Input |
| 27 | SCLK | D_IN | SPI Bus. Serial clock |
| 28 | NCS | D_IN | No Chip Select (Active low) |
| 29 | INTB | D_OUT | This output pin generates a low pulse when an Interrupt condition occurs. Pulse duration is configurable |
| 30 | VDDIO | A_IN | Input voltage for MISO output buffer. Allows voltage compatibility with MCU I/Os. |
| 31 | SELECT | D_IN | Hardware selection pin for VAUX and VCCA output voltages |
| 32 | FB_CORE | A_IN | VCORE voltage feedback. Input of the error amplifier. |
| 33 | COMP_CORE | A_IN | Compensation network. Output of the error amplifier. |
| 34 | VCORE_SNS | A_IN | Vcore output voltage sense |
| 35 | SW_CORE | A_IN | VCORE switching point |
| 36 | BOOT_CORE | A_IN/OUT | Bootstrap capacitor for VCORE internal NMOS gate drive |

Table 2. 33907_8 Pin Definition

| Pin | Pin Name | Type | Definition |
|-----|----------|----------|---|
| 37 | VPRE | A_OUT | VPRE output voltage |
| 38 | VAUX | A_OUT | VAUX output voltage. External PNP ballast transistor. Collector connection |
| 39 | VAUX_B | A_OUT | VAUX voltage regulator. External PNP ballast transistor. Base connection |
| 40 | VAUX_E | A_OUT | VAUX voltage regulator. External PNP ballast transistor. Emitter connection |
| 41 | VCCA_E | A_OUT | VCCA voltage regulator. External PNP ballast transistor. Emitter connection |
| 42 | VCCA_B | A_OUT | VCCA voltage regulator. External PNP ballast transistor. Base connection |
| 43 | VCCA | A_OUT | VCCA output voltage. External PNP ballast transistor. Collector connection |
| 44 | GATE_LS | A_OUT | Low side MOSFET gate drive for "Non-inverting Buck-boost" configuration |
| 45 | DGND | GROUND | Digital ground connection |
| 46 | BOOT_PRE | A_IN/OUT | Bootstrap capacitor for the VPRE internal NMOS gate drive |
| 47 | SW_PRE2 | A_IN | Second pre-regulator switching point |
| 48 | SW_PRE1 | A_IN | Pre-regulator switching point |

4 General Product Characteristics

4.1 Maximum Ratings

Table 3. Maximum Ratings

All voltages are with respect to ground, unless otherwise specified. Exceeding these ratings may cause a malfunction or permanent damage to the device.

| Ratings | Symbol | Value | Unit | Notes |
|--|-------------------|------------------------|------|-------|
| ELECTRICAL RATINGS | | | | |
| DC Voltage at Power Supply Pins | $V_{SUP1/2/3}$ | -1.0 to 40 | V | |
| DC voltage between VSUP1, 2, and VSUP3 ($V_{SUP1,2} > V_{SUP3}$) | $V_{SUP1/2/3}$ | 0.0 to 4.0 | V | |
| DC Voltage at Battery Sense Pin | V_{SENSE} | -14 to 40 | V | |
| DC Voltage at SW_PRE1 and SW_PRE2 Pins | $V_{SW1, 2}$ | -1.0 to 40 | V | |
| DC Voltage at VPRE Pin | V_{PRE} | -0.3 to 8 | V | |
| DC Voltage at Gate_LS pin | V_{GATE_LS} | -0.3 to 8 | V | |
| DC Voltage at BOOT_PRE pin | V_{BOOT_PRE} | -1.0 to 50 | V | |
| DC Voltage at SW_CORE pin | V_{SW_CORE} | -1.0 to 8.0 | V | |
| DC Voltage at VCORE_SNS pin | V_{CORE_SNS} | 0.0 to 8.0 | V | |
| DC Voltage at BOOT_CORE pin | V_{BOOT_CORE} | 0.0 to 15 | V | |
| DC Voltage at FB_CORE pin | V_{FB_CORE} | -0.3 to 2.5 | V | |
| DC Voltage at COMP_CORE pin | V_{COMP_CORE} | -0.3 to 2.5 | V | |
| DC Voltage at VAUX_E, VAUX_B pin | $V_{AUX_E,B}$ | -0.3 to 40 | V | |
| DC Voltage at VAUX pin | V_{AUX} | -2.0 to 40 | V | |
| DC Voltage at VCCA_B, VCCA_E pin | $V_{CCA_B,E}$ | -0.3 to 8.0 | V | |
| DC Voltage at VCCA pin | V_{CCA} | -0.3 to 8.0 | V | |
| DC Voltage at VDDIO | V_{DDIO} | -0.3 to 8.0 | V | |
| DC Voltage at FS0B (with ext R mandatory) | V_{FS0} | -0.3 to 40 | V | |
| DC Voltage at DEBUG | V_{DEBUG} | -0.3 to 40 | V | |
| DC Voltage at IO_0:1; 4:5 (with ext R = 5.1 k Ω in series mandatory) | $V_{IO_0,1,4,5}$ | -0.3 to 40 | V | |
| DC Voltage at INTB, RSTB, MISO, MOSI, NCS, SCLK, MUX_OUT, RXD, TXD, IO_2, IO_3 | V_{DIG} | -0.3 to $V_{DDIO}+0.3$ | V | |
| DC Voltage at SELECT | V_{SELECT} | -0.3 to 8.0 | V | |
| DC Voltage on CANL, CANH | V_{BUS_CAN} | -27 to 40 | V | |
| DC voltage on CAN_5 V | V_{CAN_5V} | -0.3 to 8.0 | V | |
| IOs maximum current capability | I_{IO} | -5.0 to 5.0 | mA | |

Table 3. Maximum Ratings (continued)

All voltages are with respect to ground, unless otherwise specified. Exceeding these ratings may cause a malfunction or permanent damage to the device.

| Ratings | Symbol | Value | Unit | Notes |
|---|----------------|-------|------|-------|
| ESD Voltage | | | | |
| Human Body Model (JESD22/A114) - 100 pF, 1.5 kΩ | | | | |
| • All pins | $V_{ESD-HBM1}$ | ±2.0 | kV | |
| • VSUP1, VSUP2, VSUP3, VSENSE, IO_0:1, IO_4:5, FS0B, DEBUG | $V_{ESD-HBM2}$ | ±3.5 | kV | |
| • VAUX versus AGND | $V_{ESD-HBM3}$ | ±4.0 | kV | |
| • CANH, CANL | $V_{ESD-HBM4}$ | ±6.0 | kV | |
| Charge Device Model (JESD22/C101): | | | | |
| • All Pins | $V_{ESD-CDM1}$ | ±500 | V | |
| • Corner Pins | $V_{ESD-CDM2}$ | ±750 | V | |
| System level ESD (Gun Test) | | | | |
| • VSUP1, VSUP2, VSUP3, VSENSE, VAUX, IO_0:1, IO_4:5, FS0B | | | | |
| 330 Ω / 150 pF Unpowered According to IEC61000-4-2: | $V_{ESD-GUN1}$ | ±8.0 | kV | |
| 330 Ω / 150 pF Unpowered According to OEM LIN, CAN, FLEXRAY Conformance | $V_{ESD-GUN2}$ | ±8.0 | kV | |
| 2.0 kΩ / 150 pF Unpowered According to ISO10605.2008 | $V_{ESD-GUN3}$ | ±8.0 | kV | |
| 2.0 kΩ / 330 pF Powered According to ISO10605.2008 | $V_{ESD-GUN4}$ | ±8.0 | kV | |
| • CANH, CANL | | | | |
| 330 Ω / 150 pF Unpowered According to IEC61000-4-2: | $V_{ESD-GUN5}$ | ±15 | kV | |
| 330 Ω / 150 pF Unpowered According to OEM LIN, CAN, FLEXRAY Conformance | $V_{ESD-GUN6}$ | ±12 | kV | |
| 2.0 kΩ / 150 pF Unpowered According to ISO10605.2008 | $V_{ESD-GUN7}$ | ±15 | kV | |
| 2.0 kΩ / 330 pF Powered According to ISO10605.2008 | $V_{ESD-GUN8}$ | ±15 | kV | |

THERMAL RATINGS

| | | | | |
|----------------------|-----------|------------|----|--|
| Ambient Temperature | T_A | -40 to 125 | °C | |
| Junction Temperature | T_J | -40 to 150 | °C | |
| Storage Temperature | T_{STG} | -55 to 150 | °C | |

THERMAL RESISTANCE

| | | | | |
|--|-----------------------|-----|------|-----|
| Thermal resistance junction to ambient | $R_{\theta JA}$ | 32 | °C/W | (2) |
| Thermal resistance junction to Case Top | $R_{\theta JCTOP}$ | 23 | °C/W | (3) |
| Thermal resistance junction to Case Bottom | $R_{\theta JCBOTTOM}$ | 1.3 | °C/W | (4) |

Notes

- Per JEDEC JESD51-6 with the board (JESD51-7) horizontal.
- Thermal resistance between the die and the case top surface as measured by the cold plate method (MIL SPEC - 883 Method 1012.1).
- Thermal resistance between the die and the solder pad on the bottom of the package based on simulation without any interface resistance.

4.2 Static Electrical Characteristics

Table 4. Operating Range

$T_{CASE} = -40$ to 125 °C, unless otherwise specified. $V_{SUP} = V_{SUP_UV_L}$ to 40 V, unless otherwise specified. All voltages referenced to ground. When $28\text{ V} < V_{SUP} < 40\text{ V}$, thermal dissipation must be considered (Figure 22).

| Symbol | Parameter | Min | Typ | Max | Unit | Notes |
|--|--|--------------------|---|------|------|-------|
| POWER SUPPLY | | | | | | |
| I_{SUP} | Power Supply Current in Normal Mode ($V_{sup} > V_{sup_uv_7}$) | 2.0 | – | 13.0 | mA | |
| I_{SUP_LPOFF1} | Power Supply Current in LPOFF (14 V, @ $T_A = 25$ °C) | – | 32 | – | μA | |
| I_{SUP_LPOFF2} | Power Supply Current in LPOFF (18 V, @ $T_A = 80$ °C) | – | 42 | 60 | μA | |
| V_{SNS_UV} | Power Supply Undervoltage Warning | – | 8.5 | – | V | |
| $V_{SNS_UV_HYST}$ | Power Supply Undervoltage Hysteresis | 0.1 | – | – | V | |
| $V_{SUP_UV_7}$ | Power Supply Undervoltage Lockout (power-up) | 7.0 | – | 8.2 | V | |
| $V_{SUP_UV_5}$ | Power Supply Undervoltage Lockout (power-up) | – | – | 5.6 | V | |
| $V_{SUP_UV_L}$ | Power Supply Undervoltage Lockout (falling - Boost config.) | – | – | 2.7 | V | |
| $V_{SUP_UV_L_B}$ | Power Supply Undervoltage Lockout (falling - Buck config.) | – | – | 4.6 | V | |
| $V_{SUP_UV_HYST}$ | Power Supply Undervoltage Lockout Hysteresis | – | 0.1 | – | V | (5) |
| V_{PRE} VOLTAGE PRE-REGULATOR | | | | | | |
| V_{PRE} | V_{PRE} Output Voltage <ul style="list-style-type: none"> Buck mode ($V_{SUP} > V_{sup_uv_7}$) Buck mode ($V_{SUP_UV_7} \geq V_{SUP} \geq 4.6\text{ V}$) Boost mode ($V_{SUP} \geq 2.7\text{ V}$) | 6.25 | – | 6.75 | V | |
| | | $V_{PRE_UV_4P3}$ | $V_{SUP} - R_{DS(on)_PRE} \cdot I_{PRE}$ | – | | |
| | | 6.0 | – | 7.0 | | |
| I_{PRE} | V_{PRE} Maximum Output Current Capability <ul style="list-style-type: none"> Buck or Boost with $V_{SUP} > V_{SUP_UV_7}$ Buck with $V_{SUP_UV_7} \geq V_{SUP} \geq 4.6\text{ V}$ Boost with $V_{SUP_UV_7} \geq V_{SUP} \geq 6.0\text{ V}$ Boost with $6.0\text{ V} \geq V_{SUP} \geq 4.0\text{ V}$ Boost with $4.0\text{ V} \geq V_{SUP} \geq 2.7\text{ V}$ | 2.0 | – | – | A | (5) |
| | | 0.5 | 2.0 | – | | |
| | | 2.0 | – | – | | |
| | | 1.0 | – | – | | |
| | | 0.3 | – | – | | |
| I_{PRE_LPOFF} | V_{PRE} Maximum Output Current Capability in LPOFF at low V_{sup} voltage <ul style="list-style-type: none"> Buck with $V_{SUP_UV_7} \geq V_{SUP} \geq 4.6\text{ V}$ Boost with $V_{SUP_UV_7} \geq V_{SUP} \geq 6.0\text{ V}$ Boost with $6.0\text{ V} \geq V_{SUP} \geq 4.0\text{ V}$ Boost with $4.0\text{ V} \geq V_{SUP} \geq 2.7\text{ V}$ | 0.050 | – | – | A | (5) |
| | | 2.0 | – | – | | |
| | | 1.0 | – | – | | |
| | | 0.3 | – | – | | |
| I_{PRE_LIM} | V_{PRE} Output Current Limitation with $V_{sup} \leq 28\text{V}$ | 3.5 | – | – | A | |
| I_{PRE_OC} | V_{PRE} Overcurrent Detection Threshold (in buck mode only) with $V_{SUP} \leq 28\text{ V}$ | 5.0 | – | – | A | |
| V_{PRE_UV} | V_{PRE} Undervoltage Detection Threshold (Falling) | 5.5 | – | 6.0 | V | |
| $V_{PRE_UV_HYST}$ | V_{PRE} Undervoltage Hysteresis | 0.05 | – | 0.15 | V | (5) |
| $V_{PRE_UV_4P3}$ | V_{PRE} Shut-off Threshold (Falling - buck mode) | 4.2 | – | 4.5 | V | |

Notes

5. Guaranteed by design.

Table 4. Operating Range (continued)

$T_{CASE} = -40$ to 125 °C, unless otherwise specified. $V_{SUP} = V_{SUP_UV_L}$ to 40 V, unless otherwise specified. All voltages referenced to ground. When 28 V $< V_{SUP} < 40$ V, thermal dissipation must be considered (Figure 22).

| Symbol | Parameter | Min | Typ | Max | Unit | Notes |
|--|---|---------------------|------------|------------------|------|----------|
| V_{PRE} VOLTAGE PRE-REGULATOR (CONTINUED) | | | | | | |
| V _{PRE_UV_4P3_HYST} | V _{PRE} Shut-off Hysteresis | 0.05 | – | 0.15 | V | (6) |
| R _{DSON_PRE} | V _{PRE} Pass Transistor On Resistance with $V_{SUP} \leq 28$ V | – | – | 200 | mΩ | |
| L _{IR_VPRE} | V _{PRE} Line Regulation | – | 20 | – | mV | (6) |
| LOR _{VPRE_BUCK} | V _{PRE} Load Regulation for $C_{OUT} = 57$ μF I _{PRE} from 50 mA to 2.0 A - Buck mode | – | 100 | – | mV | (6) |
| LOR _{VPRE_BOOST} | V _{PRE} Load Regulation for $C_{OUT} = 57$ μF I _{PRE} from 50 mA to 2.0 A - Boost mode | – | 500 | – | mV | (6) |
| V _{PRE_LL_H} V _{PRE_LL_L} | V _{PRE} Pulse Skipping Thresholds | – – | 200 180 | – – | mV | |
| T _{WARN_PRE} | V _{PRE} Thermal Warning Threshold | – | 125 | – | °C | |
| T _{SD_PRE} | V _{PRE} Thermal Shutdown Threshold | 160 | – | – | °C | |
| T _{SD_PRE_HYST} | V _{PRE} Thermal Shutdown Hysteresis | – | 10 | – | °C | (6) |
| V _{SUP_IPFF} | I _{PPF} Input Voltage detection | 18 | – | 24 | V | |
| V _{SUP_IPFF_HYST} | I _{PPF} Input Voltage hysteresis | 0.2 | – | – | V | |
| I _{PRE_IPFF_PK} | I _{PPF} High Side Peak current detection with $V_{SUP} \leq 28$ V | 1.7 | – | – | A | |
| V _{G_LS_OH} | LS Gate driver High output voltage (I _{OUT} = 50 mA) | V _{PRE} -1 | – | V _{PRE} | V | |
| V _{G_LS_OL} | LS Gate driver Low Level (I _{OUT} = 50 mA) | – | – | 0.5 | V | |
| V_{CORE} VOLTAGE REGULATOR | | | | | | |
| V _{CORE_FB} | V _{CORE} Feedback Input Voltage | 0.784 | 0.8 | 0.816 | V | |
| I _{CORE} | V _{CORE} Output Current Capability in Normal Mode • MC33907 • MC33908 | – – | – – | 0.8 1.5 | A | |
| I _{CORE_LIM_10} I _{CORE_LIM_20} | V _{CORE} Output Current Limitation • MC33907 • MC33908 | 1.0 1.8 | – – | 2.0 3.5 | A | |
| R _{DSON_CORE} | V _{CORE} Pass Transistor On Resistance | – | – | 200 | mΩ | |
| LOR _{VCORE_1.2} | V _{CORE} Transient Load regulation - 1.2 V range | -60 | – | 60 | mV | (6), (7) |
| LOR _{VCORE_3.3} | V _{CORE} Transient Load regulation - 3.3 V range | -100 | – | 100 | mV | (6), (7) |
| T _{WARN_CORE} | V _{CORE} Thermal Warning Threshold | – | 125 | – | °C | |
| T _{SD_CORE} | V _{CORE} Thermal Shutdown Threshold | 160 | – | – | °C | |
| T _{SD_CORE_HYST} | V _{CORE} Thermal Shutdown Hysteresis | – | 10 | – | °C | (6) |

Notes

- Guaranteed by design.
- $C_{OUT} = 40$ μF, I_{CORE} = 10 mA to 1.5 A, dI_{CORE}/dt ≤ 2.0 A/μs

Table 4. Operating Range (continued)

$T_{CASE} = -40$ to 125 °C, unless otherwise specified. $V_{SUP} = V_{SUP_UV_L}$ to 40 V, unless otherwise specified. All voltages referenced to ground. When 28 V $< V_{SUP} < 40$ V, thermal dissipation must be considered (Figure 22).

| Symbol | Parameter | Min | Typ | Max | Unit | Notes |
|--|---|--------|-----|--------|------|-------|
| V_{CCA} VOLTAGE REGULATOR | | | | | | |
| V _{CCA} | V _{CCA} Output Voltage <ul style="list-style-type: none"> 5.0 V config. with Internal ballast at 100 mA 5.0 V config with external ballast at 200 mA 5.0 V config with external ballast at 300 mA 3.3 V config with Internal ballast at 100 mA 3.3 V config with external ballast at 200 mA 3.3 V config with external ballast at 300 mA | 4.95 | 5.0 | 5.05 | V | (8) |
| | | 4.9 | 5.0 | 5.1 | | |
| | | 4.85 | 5.0 | 5.15 | | |
| | | 3.2505 | 3.3 | 3.3495 | | (8) |
| | | 3.234 | 3.3 | 3.366 | | |
| | | 3.201 | 3.3 | 3.399 | | |
| I _{CCA_IN} | V _{CCA} Output Current (int. MOSFET) | – | – | 100 | mA | |
| I _{CCA_OUT} | V _{CCA} Output Current (external PNP) | – | – | 300 | mA | |
| I _{CCA_LIM_INT} | V _{CCA} Output Current Limitation (int. MOSFET) | 100 | – | 675 | mA | |
| I _{CCA_LIM_OUT} | V _{CCA} Output Current Limitation (external PNP) | 300 | – | 675 | mA | |
| I _{CCA_LIM_FB} | V _{CCA} Output Current Limitation Foldback | 80 | – | 200 | mA | |
| V _{CCA_LIM_FB} | V _{CCA} Output Voltage Foldback Threshold | 0.5 | – | 1.1 | V | |
| V _{CCA_LIM_HYST} | V _{CCA} Output Voltage Foldback Hysteresis | 0.07 | – | 0.3 | V | |
| I _{CCA_BASE_SC} | V _{CCA} Base Current Capability (internal pull-up) | – | 20 | 30 | mA | |
| I _{CCA_BASE_SK} | V _{CCA} Base Current Capability (Current sink) | 20 | 65 | – | mA | |
| T _{WARN_CCA} | V _{CCA} Thermal Warning Threshold (int. ballast only) | – | 125 | – | °C | |
| T _{SD_CCA} | V _{CCA} Thermal Shutdown Threshold (int. ballast only) | 160 | – | – | °C | |
| T _{SD_CCA_HYST} | V _{CCA} Thermal Shutdown Hysteresis | – | 10 | – | °C | (9) |
| LORT _{VCCA} | V _{CCA} Transient Load Regulation <ul style="list-style-type: none"> I_{CCA} = 10 mA to 100 mA (internal MOSFET) I_{CCA} = 10 mA to 300 mA (external ballast) | – | – | 1.0 | % | (9) |

Notes

- External PNP gain within 150 to 450
- Guaranteed by design.

Table 4. Operating Range (continued)

$T_{CASE} = -40$ to 125 °C, unless otherwise specified. $V_{SUP} = V_{SUP_UV_L}$ to 40 V, unless otherwise specified. All voltages referenced to ground. When 28 V $< V_{SUP} < 40$ V, thermal dissipation must be considered (Figure 22).

| Symbol | Parameter | Min | Typ | Max | Unit | Notes |
|--------|-----------|-----|-----|-----|------|-------|
|--------|-----------|-----|-----|-----|------|-------|

VAUX VOLTAGE REGULATOR

| | | | | | | |
|--|---|----------|--------|-----------|----|------|
| V_{AUX_5} | V_{AUX} Output Voltage (5.0 V configuration) | 4.85 | 5.0 | 5.15 | V | |
| V_{AUX_33} | V_{AUX} Output Voltage (3.3 V configuration) | 3.2 | 3.3 | 3.4 | V | |
| V_{AUX_TRK} | V_{AUX} Tracking Error (V_{AUX_5} and V_{AUX_33}) | -15 | - | +15 | mV | |
| I_{AUX_OUT} | V_{AUX} Output Current | - | - | 300 | mA | |
| I_{AUX_LIM} | V_{AUX} Output Current Limitation | 300 | - | 700 | mA | |
| $I_{AUX_LIM_FB}$ | V_{AUX} Output Current Limitation Foldback | 100 | - | 530 | mA | |
| $V_{AUX_LIM_FB}$ | V_{AUX} Output Voltage Foldback Threshold | 0.5 | - | 1.1 | V | |
| $V_{AUX_LIM_HYST}$ | V_{AUX} Output Voltage Foldback Hysteresis | 0.05 | - | 0.3 | V | |
| $I_{AUX_BASE_SC}$ $I_{AUX_BASE_SK}$ | V_{AUX} Base Current Capability | - 7.0 | - - | -7.0 - | mA | |
| TSD_{AUX} | V_{AUX} Thermal Shutdown Threshold | 160 | - | - | °C | |
| TSD_{AUX_HYST} | V_{AUX} Thermal Shutdown Hysteresis | - | 10 | - | °C | (10) |
| LOR_{VAUX} | V_{AUX} Static Load Regulation ($I_{AUX_OUT} = 10$ to 300 mA) | - | 15 | - | mV | (10) |
| $LORT_{VAUX}$ | V_{AUX} Transient Load Regulation • $I_{AUX_OUT} = 10$ mA to 300 mA | - | - | 1.0 | % | (10) |

5V-CAN VOLTAGE REGULATOR

| | | | | | | |
|---------------------|--|------|-----|------|----|------|
| V_{CAN} | V_{CAN} Output Voltage $V_{SUP} > 6.0$ V in Buck mode $V_{SUP} > V_{SUP_UV_L}$ in Boost mode | 4.8 | 5.0 | 5.2 | V | |
| I_{CAN_OUT} | V_{CAN} Output Current | - | - | 100 | mA | |
| I_{CAN_LIM} | V_{CAN} Output Current Limitation | 100 | - | 250 | mA | |
| TSD_{CAN} | V_{CAN} Thermal Shutdown Threshold | 160 | - | - | °C | |
| TSD_{CAN_HYST} | V_{CAN} Thermal Shutdown Hysteresis | - | 10 | - | °C | (10) |
| V_{CAN_UV} | V_{CAN} Undervoltage Detection Threshold | 4.25 | - | 4.8 | V | |
| $V_{CAN_UV_HYST}$ | V_{CAN} Undervoltage Hysteresis | 0.07 | - | 0.22 | V | |
| V_{CAN_OV} | V_{CAN} Overvoltage Detection Threshold | 5.2 | - | 5.55 | V | |
| $V_{CAN_OV_HYST}$ | V_{CAN} Overvoltage Hysteresis | 0.07 | - | 0.22 | V | |
| LOR_{VCAN} | V_{CAN} Load Regulation (from 0 to 50 mA) | - | 100 | - | mV | (10) |

Notes

10. Guaranteed by design.

Table 4. Operating Range (continued)

$T_{CASE} = -40$ to 125 °C, unless otherwise specified. $V_{SUP} = V_{SUP_UV_L}$ to 40 V, unless otherwise specified. All voltages referenced to ground. When 28 V $< V_{SUP} < 40$ V, thermal dissipation must be considered (Figure 22).

| Symbol | Parameter | Min | Typ | Max | Unit | Notes |
|---|--|------|------|-------|------|-------|
| FAIL-SAFE MACHINE VOLTAGE SUPERVISOR | | | | | | |
| V_{PRE_OV} | V_{PRE} Overvoltage Detection Threshold | 7.2 | – | 8.0 | V | |
| $V_{PRE_OV_HYST}$ | V_{PRE} Overvoltage Hysteresis | – | 0.1 | – | V | (11) |
| $V_{CORE_FB_UV}$ | V_{CORE} FB Undervoltage Detection Threshold | 0.67 | – | 0.773 | V | |
| $V_{CORE_FB_UV_D}$ | V_{CORE} FB Undervoltage Detection Threshold - Degraded mode | 0.45 | – | 0.58 | V | |
| $V_{CORE_FB_UV_HYST}$ | V_{CORE} FB Undervoltage Hysteresis | 10 | – | 27 | mV | (11) |
| $V_{CORE_FB_OV}$ | V_{CORE} FB Overvoltage Detection Threshold | 0.84 | – | 0.905 | V | |
| $V_{CORE_FB_OV_HYST}$ | V_{CORE} FB Overvoltage Hysteresis | 10 | – | 30 | mV | (11) |
| I_{PD_CORE} | V_{CORE} Internal Pull-down Current | 5.0 | 12 | 25 | mA | |
| $V_{CCA_UV_5}$ | V_{CCA} Undervoltage Detection Threshold (5.0 V config) | 4.5 | – | 4.75 | V | |
| $V_{CCA_UV_5D}$ | V_{CCA} Undervoltage Detection Threshold (Degraded 5.0 V) | 3.0 | – | 3.2 | V | |
| $V_{CCA_UV_33}$ | V_{CCA} Undervoltage Detection Threshold (3.3 V config) | 3.0 | – | 3.2 | V | |
| $V_{CCA_UV_HYST}$ | V_{CCA} Undervoltage Hysteresis | – | 0.07 | – | V | (11) |
| $V_{CCA_OV_5}$ | V_{CCA} Overvoltage Detection Threshold (5.0 V config) | 5.25 | – | 5.5 | V | |
| $V_{CCA_OV_33}$ | V_{CCA} Overvoltage Detection Threshold (3.3 V config) | 3.4 | – | 3.6 | V | |
| $V_{CCA_OV_HYST}$ | V_{CCA} Overvoltage Hysteresis | – | 0.15 | – | V | (11) |
| R_{PD_CCA} | V_{CCA} Internal Pull-down Resistor (enabled when V_{CCA} is switched off) | 50 | – | 160 | Ω | |
| $V_{AUX_UV_5}$ | V_{AUX} Undervoltage Detection Threshold (5.0 V config) | 4.5 | – | 4.75 | V | |
| $V_{AUX_UV_5D}$ | V_{AUX} Undervoltage Detection Threshold (Degraded 5.0 V) | 3.0 | – | 3.2 | V | |
| $V_{AUX_UV_33}$ | V_{AUX} Undervoltage Detection Threshold (3.3 V config) | 3.0 | – | 3.2 | V | |
| $V_{AUX_UV_HYST}$ | V_{AUX} Undervoltage Hysteresis | – | 0.07 | – | V | (11) |
| $V_{AUX_OV_5}$ | V_{AUX} Overvoltage Detection Threshold (5.0 V config) | 5.25 | – | 5.5 | V | |
| $V_{AUX_OV_33}$ | V_{AUX} Overvoltage Detection Threshold (3.3 V config) | 3.4 | – | 3.6 | V | |
| $V_{AUX_OV_HYST}$ | V_{AUX} Overvoltage Hysteresis | – | 0.07 | – | V | (11) |
| R_{PD_AUX} | V_{AUX} Internal Pull-down Resistor | 50 | – | 170 | Ω | |

Notes

- 11. Guaranteed by design.

Table 4. Operating Range (continued)

$T_{CASE} = -40$ to 125 °C, unless otherwise specified. $V_{SUP} = V_{SUP_UV_L}$ to 40 V, unless otherwise specified. All voltages referenced to ground. When 28 V $< V_{SUP} < 40$ V, thermal dissipation must be considered (Figure 22).

| Symbol | Parameter | Min | Typ | Max | Unit | Notes |
|--|--|-----------------|--------|-----------|------|-------|
| FAIL-SAFE OUTPUTS | | | | | | |
| V_{RSTB_OL} | Reset Low Output Level ($I_{RSTB} = 2.0$ mA and 2.0 V $< V_{SUP} < 40$ V) | – | – | 0.5 | V | (12) |
| I_{RSTB_LIM} | Reset Output Current Limitation | 12 | – | 25 | mA | |
| V_{RSTB_IL} | External Reset Detection Threshold (falling) | 1.0 | – | | V | |
| V_{RSTB_IH} | External Reset Detection Threshold (rising) | – | – | 2.0 | V | |
| $V_{RSTB_IN_HYST}$ | External Reset Input Hysteresis | 0.2 | – | – | V | |
| V_{FS0B_OL} | FS0B low Output Level ($I_{FS0b} = 2.0$ mA) | – | – | 0.5 | V | |
| I_{FS0B_LK} | FS0B Input Current Leakage ($V_{FS0B} = 28$ V) | – | – | 1.0 | μA | |
| I_{FS0B_LIM} | FS0B Output Current Limitation | 6.0 | – | 12 | mA | |
| MULTI-PURPOSE IOS | | | | | | |
| ANALOG INPUT | | | | | | |
| $V_{IO_ANA_WD}$ | Measurable Input Voltage (wide range) | 3.0 | – | 19 | V | |
| $V_{IO_ANA_TG}$ | Measurable Input Voltage (tight range) | 3.0 | – | 9.0 | V | |
| $I_{IO_IN_ANA}$ | Input Current | – | – | 100 | μA | |
| DIGITAL INPUT | | | | | | |
| V_{IO_IH} | High Input Voltage Detection Threshold (IO_0:1, IO_4:5) • Min Limit = 2.7 V at $V_{SUP} = 40$ V | 2.6 | – | – | V | |
| V_{IO23_IH} | High Input Voltage Detection Threshold (IO_2, IO_3) | 2.0 | – | – | V | |
| V_{IO_IL} | Digital Low Input Level (IO_0:1; IO_4:5) | – | – | 2.1 | V | |
| V_{IO_HYST} | Input Voltage Hysteresis (IO_0:1, IO_4:5) | 50 | 120 | 500 | mV | (13) |
| V_{IO23_IL} | Digital Low Input Level (IO_2, IO_3) | – | – | 0.9 | V | |
| V_{IO23_HYST} | Input Voltage Hysteresis (IO_2, IO_3) | 200 | 450 | 700 | mV | (13) |
| $I_{IO_IN_0:1}$ | Input Current for IO_0:1 | -5.0 | – | 100 | μA | |
| $I_{IO_IN_2:5}$ | Input Current for IO_2:5 | -5.0 | – | 5.0 | μA | |
| $I_{IO_IN_LPOFF}$ | Input Current for IO_0:5 in LPOFF | -1.0 | – | 1.0 | μA | |
| OUTPUT GATE DRIVER | | | | | | |
| V_{IO_OH} | High Output Level at $I_{IO_OUT} = -2.5$ mA | $V_{PRE} - 1.5$ | – | V_{PRE} | V | |
| V_{IO_OL} | Low Output Level at $I_{IO_OUT} = +2.5$ mA | 0.0 | – | 1.0 | V | |
| $V_{IO_OUT_SK}$ $V_{IO_OUT_SC}$ | Output Current Capability | 2.5 – | – – | – -2.5 | mA | |

Notes

12. For $V_{SUP} < 2.0$ V, all supplies are already off and external pull-up on RSTB (e.g V_{CORE} or V_{CCA}) pulls the line down.
13. Guaranteed by design.

Table 4. Operating Range (continued)

$T_{CASE} = -40$ to 125 °C, unless otherwise specified. $V_{SUP} = V_{SUP_UV_L}$ to 40 V, unless otherwise specified. All voltages referenced to ground. When 28 V $< V_{SUP} < 40$ V, thermal dissipation must be considered (Figure 22).

| Symbol | Parameter | Min | Typ | Max | Unit | Notes |
|--------|-----------|-----|-----|-----|------|-------|
|--------|-----------|-----|-----|-----|------|-------|

ANALOG MULTIPLEXER

| | | | | | | |
|---------------------|--|-------|------|-------|-------|------|
| V_{AMUX_ACC} | Voltage Sense Accuracy (V_{SNS} , IO_0, IO_1) using 5.1 k Ω resistor | -5.0 | – | 5.0 | % | (14) |
| $V_{AMUX_WD_5}$ | Divider Ratio (wide input voltage range) at $V_{DDIO} = 5.0$ V | – | 5.0 | – | | |
| $V_{AMUX_WD_3P3}$ | Divider Ratio (wide input voltage range) at $V_{DDIO} = 3.3$ V | – | 7.0 | – | | |
| $V_{AMUX_TG_5}$ | Divider Ratio (tight input voltage range) at $V_{DDIO} = 5.0$ V | – | 2.0 | – | | |
| $V_{AMUX_TG_3P3}$ | Divider Ratio (tight input voltage range) at $V_{DDIO} = 3.3$ V | – | 3.0 | – | | |
| V_{AMUX_REF1} | Internal Voltage Reference with 6.0 V $< V_{SUP} < 19$ V | 2.475 | 2.5 | 2.525 | V | |
| V_{AMUX_REF2} | Internal Voltage Reference with $V_{SUP} \leq 6.0$ V or $V_{SUP} \geq 19$ V | 2.468 | 2.5 | 2.532 | V | |
| $V_{AMUX_TP_CO}$ | Internal Temperature Sensor Coefficient | – | 9.9 | – | mV/°C | |
| V_{AMUX_TP} | Temperature Sensor mux_output Voltage (at $T_J = 165$ °C) | 2.08 | 2.15 | 2.22 | V | (15) |

INTERRUPT

| | | | | | | |
|----------------|--|---|----|-----|------------|--|
| V_{INTB_OL} | Low output level ($I_{INT} = 2.5$ mA) | – | – | 0.5 | V | |
| R_{PU_INT} | Internal pull-up resistor (connected to VDDIO) | – | 10 | – | K Ω | |
| I_{INT_LK} | Input leakage current | – | – | 1 | μ A | |

CAN TRANSCEIVER**CAN LOGIC INPUT PIN (TXD)**

| | | | | | | |
|-----------------|---|-----------------------|----|-----------------------|------------|--|
| V_{TXD_IH} | TXD High Input Threshold | $0.7 \times V_{DDIO}$ | – | – | V | |
| V_{TXD_IL} | TXD Low Input Threshold | – | – | $0.3 \times V_{DDIO}$ | V | |
| $TXD_{PULL-UP}$ | TXD Main Device Pull-up | 20 | 33 | 50 | K Ω | |
| TXD_{LK} | TXD Input Leakage Current, $V_{TXD} = V_{DDIO}$ | -1.0 | – | 1.0 | μ A | |

CAN LOGIC OUTPUT PIN (RXD)

| | | | | | | |
|-----------------|--|--------------------|---|-----|---|--|
| V_{RXD_OL1} | Low Level Output Voltage ($I_{RXD} = 250$ μ A) | – | – | 0.4 | V | |
| V_{RXD_OL2} | Low Level Output Voltage ($I_{RXD} = 1.5$ mA) | – | – | 0.9 | V | |
| V_{OUT_HIGH} | High Level Output Voltage ($I_{RXD} = -250$ μ A, $V_{DDIO} = 3.0$ V to 5.5 V) | $V_{DDIO} - 0.4$ V | – | – | V | |

Notes

- If a higher resistor value than recommended is used, the accuracy degrades.
- Guaranteed by design.

Table 4. Operating Range (continued)

$T_{CASE} = -40$ to 125 °C, unless otherwise specified. $V_{SUP} = V_{SUP_UV_L}$ to 40 V, unless otherwise specified. All voltages referenced to ground. When 28 V $< V_{SUP} < 40$ V, thermal dissipation must be considered (Figure 22).

| Symbol | Parameter | Min | Typ | Max | Unit | Notes |
|-------------------------------------|--|-------------|------------|-------------|------------|-------|
| CAN OUTPUT PINS (CANH, CANL) | | | | | | |
| DIFF_COM_MODE | Differential Input Comparator Common Mode Range | -12 | – | 12 | V | |
| $V_{IN_DIFF_SLEEP}$ | Differential Input Voltage Threshold in Sleep Mode | 0.5 | – | 0.9 | V | |
| V_{IN_HYST} | Differential Input Hysteresis (in Tx, Rx mode) | 50 | – | – | mV | |
| R_{IN_CHCL} | CANH, CANL Input Resistance | 5.0 | – | 50 | k Ω | |
| R_{IN_DIFF} | CAN Differential Input Resistance | 10 | – | 100 | k Ω | |
| R_{IN_MATCH} | Input Resistance Matching | -3.0 | – | 3.0 | % | |
| V_{CANH} | CANH Output Voltage ($45 \Omega < R_{BUS} < 65 \Omega$) • TX dominant state • TX recessive state | 2.75 2.0 | – 2.5 | 4.5 3.0 | V | |
| V_{CANL} | CANL Output Voltage ($45 \Omega < R_{BUS} < 65 \Omega$) • TX dominant state • TX recessive state | 0.5 2.0 | – 2.5 | 2.25 3.0 | V | |
| $V_{OH}-V_{OL}$ | Differential Output Voltage • TX dominant state ($45 \Omega < R_{BUS} < 65 \Omega$) • TX recessive state | 1.5 -50 | 2.0 0.0 | 3.0 50 | V mV | |
| $I_{CANL-SK}$ | CANL Sink Current Under Short-circuit Condition ($V_{CANL} \leq 12$ V, CANL driver ON, TXD low) | 40 | – | 100 | mA | |
| $I_{CANH-SC}$ | CANH Source Current Under Short-circuit Condition ($V_{CANH} = -2.0$ V, CANH driver ON, TXD low) | -100 | – | -40 | mA | |
| $R_{INSLEEP}$ | CANH, CANL Input Resistance Device Supplied and in CAN Sleep Mode | 5.0 | – | 50 | k Ω | |
| V_{CANLP} | CANL, CANH Output Voltage in Sleep Modes. No Termination load. | -0.1 | 0.0 | 0.1 | V | |
| I_{CAN} | CANH, CANL Input Current, Device Unsupplied, V_{SUP} and V_{IO} connected to GND • $V_{CANH}, V_{CANL} = 5.0$ V | -10 | – | 10 | μ A | |
| T_{OT} | Overtemperature Detection | 160 | – | – | °C | |
| T_{HYST} | Overtemperature Hysteresis | -10 | – | +20 | °C | |

DIGITAL INTERFACE

| | | | | | | |
|---------------|--|------------------|-----|-----|------------|--|
| $MISO_H$ | High Output Level on MISO ($I_{MISO} = 1.5$ mA) | $V_{DDIO} - 0.4$ | – | – | V | |
| $MISO_L$ | Low Output Level on MISO ($I_{MISO} = 2.0$ mA) | – | – | 0.4 | V | |
| I_{MISO} | Tri-state Leakage Current ($V_{DDIO} = 5.0$ V) | -5.0 | – | 5.0 | μ A | |
| V_{DDIO} | Supply Voltage for MISO Output Buffer | 3.0 | – | 5.5 | V | |
| SPI_{LK} | SCLK,NCS,MOSI Input Current | -1.0 | – | 1.0 | μ A | |
| V_{SPI_IH} | SCLK,NCS,MOSI High Input Threshold | 2.0 | – | – | V | |
| V_{SPI_IL} | SCLK,NCS,MOSI Low Input Threshold | – | – | 0.8 | V | |
| R_{SPI} | NCS,MOSI Internal Pull-up (pull-up to V_{DDIO}) | 200 | 400 | 800 | K Ω | |

Table 4. Operating Range (continued)

$T_{CASE} = -40$ to 125 °C, unless otherwise specified. $V_{SUP} = V_{SUP_UV_L}$ to 40 V, unless otherwise specified. All voltages referenced to ground. When $28\text{ V} < V_{SUP} < 40\text{ V}$, thermal dissipation must be considered ([Figure 22](#)).

| Symbol | Parameter | Min | Typ | Max | Unit | Notes |
|-----------------|------------------------------|------|------|------|---------------|-------|
| DEBUG | | | | | | |
| V_{DEBUG_IL} | Low Input Voltage Threshold | 2.1 | 2.35 | 2.6 | V | |
| V_{DEBUG_IH} | High Input Voltage Threshold | 4.35 | 4.6 | 4.97 | V | |
| I_{DEBUG_LK} | Input Leakage Current | -10 | – | 10 | μA | |

4.3 Dynamic Electrical Characteristics

Table 5. Dynamic Electrical Characteristics

$T_{CASE} = -40$ to 125 °C, unless otherwise specified. $V_{SUP} = V_{SUP_UV_L}$ to 40 V, unless otherwise specified. All voltages referenced to ground. When $28\text{ V} < V_{SUP} < 40\text{ V}$, thermal dissipation must be considered ([Figure 22](#)).

| Symbol | Parameter | Min | Typ | Max | Unit | Notes |
|---------------------------------|--|-----|-----|-----|------|-------|
| DIGITAL INTERFACE TIMING | | | | | | |
| f_{SPI} | SPI Operation Frequency (50% DC) | 0.5 | – | 8.0 | MHz | |
| t_{MISO_TRANS} | MISO Transition Speed, 20 - 80% • $V_{DDIO} = 5.0\text{ V}$, $C_{LOAD} = 50\text{ pF}$ • $V_{DDIO} = 5.0\text{ V}$, $C_{LOAD} = 150\text{ pF}$ | 5.0 | – | 30 | ns | |
| | | 5.0 | – | 50 | | |
| t_{CLH} | Minimum Time SCLK = HIGH | 62 | – | – | ns | |
| t_{CLL} | Minimum Time SCLK = LOW | 62 | – | – | ns | |
| t_{PCLD} | Propagation Delay (SCLK to data at 10% of MISO rising edge) | – | – | 30 | ns | |
| t_{CSDV} | NCS = LOW to Data at MISO Active | – | – | 75 | ns | |
| t_{SCLCH} | SCLK Low Before NCS Low (setup time SCLK to NCS change H/L) | 75 | – | – | ns | |
| t_{HCLCL} | SCLK Change L/H after NCS = low | 75 | – | – | ns | |
| t_{SCLD} | SDI Input Setup Time (SCLK change H/L after MOSI data valid) | 40 | – | – | ns | |
| t_{HCLD} | SDI Input Hold Time (MOSI data hold after SCLK change H/L) | 40 | – | – | ns | |
| t_{SCLCL} | SCLK Low Before NCS High | 100 | – | – | ns | |
| t_{HCLCH} | SCLK High After NCS High | 100 | – | – | ns | |
| t_{PCHD} | NCS L/H to MISO at High-impedance | – | – | 75 | ns | |
| t_{ONNCS} | NCS Min. High Time | 500 | – | – | ns | |
| t_{NCS_MIN} | NCS Filter Time | 10 | – | 40 | ns | |

Table 5. Dynamic Electrical Characteristics (continued)

$T_{CASE} = -40$ to 125 °C, unless otherwise specified. $V_{SUP} = V_{SUP_UV_L}$ to 40 V, unless otherwise specified. All voltages referenced to ground. When 28 V < $V_{SUP} < 40$ V, thermal dissipation must be considered (Figure 22).

| Symbol | Parameter | Min | Typ | Max | Unit | Notes |
|--------|-----------|-----|-----|-----|------|-------|
|--------|-----------|-----|-----|-----|------|-------|

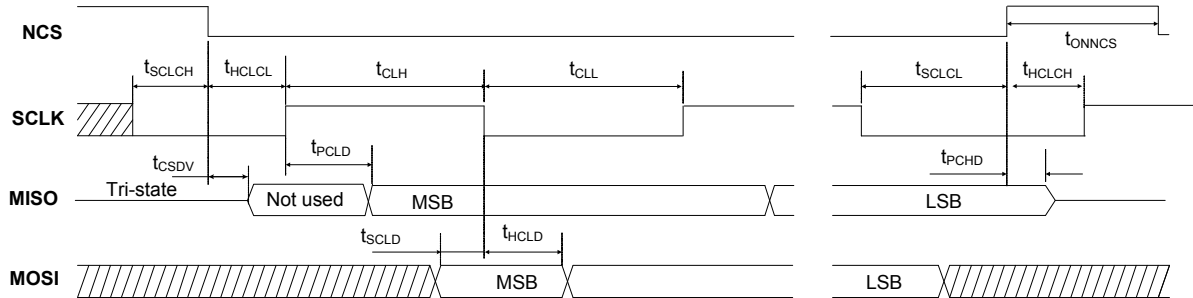

Figure 5. SPI Timing Diagram

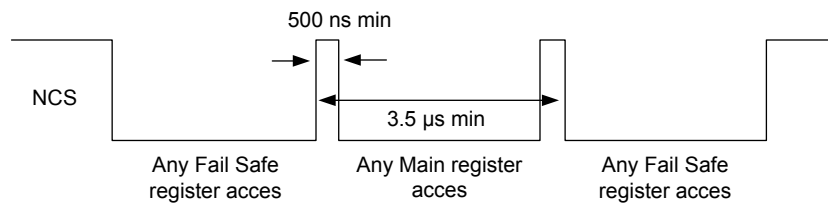

Figure 6. Register Access Restriction

Table 5. Dynamic Electrical Characteristics (continued)

$T_{CASE} = -40$ to 125 °C, unless otherwise specified. $V_{SUP} = V_{SUP_UV_L}$ to 40 V, unless otherwise specified. All voltages referenced to ground. When 28 V $< V_{SUP} < 40$ V, thermal dissipation must be considered (Figure 22).

| Symbol | Parameter | Min | Typ | Max | Unit | Notes |
|--------|-----------|-----|-----|-----|------|-------|
|--------|-----------|-----|-----|-----|------|-------|

CAN DYNAMIC CHARACTERISTICS

| | | | | | | |
|------------------|--|-----|-----|-----|---------|------|
| t_{DOUT} | TXD Dominant State Timeout | 0.8 | – | 5.0 | ms | |
| t_{DOM} | Bus Dominant Clamping Detection | 0.8 | – | 5.0 | ms | |
| t_{LOOP} | Propagation Loop Delay TXD to RXD • $R_{LOAD} = 120$ Ω , C between CANH and CANL = 100 pF, C at RxD < 15 pF | – | – | 255 | ns | |
| t_{1PWU} | Single Pulse Wake-up Time | 0.5 | – | 5.0 | μ s | |
| t_{3PWU} | Multiple Pulse Wake-up Time | 0.5 | – | 1.0 | μ s | |
| t_{3PTO1} | Multiple Pulse Wake-up Timeout (120 μ s bit selection) | 110 | 120 | – | μ s | |
| t_{3PTO2} | Multiple Pulse Wake-up Timeout (360 μ s bit selection) | 350 | 360 | – | μ s | |
| t_{CAN_READY} | Delay to enable CAN by SPI Command (NCS rising edge) to CAN to Transmit (device in normal mode and CAN interface in TxRx mode) | – | – | 100 | μ s | (16) |

FAIL-SAFE STATE MACHINE

| | | | | | | |
|----------------------------|--|-----|---|-----|---------|--|
| OSC _{FSSM} | Oscillator | 400 | – | 500 | kHz | |
| CLK _{FS_MIN} | Fail-safe Oscillator Monitoring | 150 | – | – | kHz | |
| t_{IC_ERR} | IO_0:5 Filter Time | 4.0 | – | 20 | μ s | |
| t_{ACK_FS} | Acknowledgement Counter (used for IC error handling IO_1 and IO_5) | 7.0 | – | 9.7 | ms | |
| T _{DFS_recovery} | IO_0 filter time to recover from deep reset and fail state | 0.8 | – | 1.3 | ms | |

FAIL-SAFE OUTPUT

| | | | | | | |
|-----------------------|---|-----|------|------|---------|--|
| t_{RSTB_FB} | RSTB feedback filter time | 8.0 | – | 15 | μ s | |
| t_{FSOB_FB} | FS0B feedback filter time | 8.0 | – | 15 | μ s | |
| t_{RSTB_BLK} | RSTB feedback blanking time | 180 | – | 320 | μ s | |
| t_{FSOB_BLK} | FS0B feedback blanking time | 180 | – | 320 | μ s | |
| t_{RSTB_POR} | Reset delay time (after a Power On Reset or from LPOFF) | 12 | 15.9 | 23.6 | ms | |
| t_{RSTB_LG} | Reset duration (long pulse) | 8.0 | – | 10 | ms | |
| t_{RSTB_ST} | Reset duration (short pulse) | 1.0 | – | 1.3 | ms | |
| t_{RSTB_IN} | External Reset delay time | 8.0 | – | 15 | μ s | |
| T _{FS_FB} | RSTB, FS0B Feedback Filter Time | 8.0 | – | 15 | μ s | |
| T _{DIAG_SC} | Fail-safe Output Diagnostic Counter (FS0B) | 550 | – | 800 | μ s | |

VSUP VOLTAGE SUPPLY

| | | | | | | |
|-----------------------|--------------------------|------|---|-----|------------|--|
| DV _{SUP} /DT | Supply Voltage Slew Rate | -2.0 | – | 2.0 | V/ μ s | |
|-----------------------|--------------------------|------|---|-----|------------|--|

Notes

16. For proper CAN operation, TXD must be set to high level before CAN being enabled by SPI, and must remain high for at least T_{CAN_READY}

Table 5. Dynamic Electrical Characteristics (continued)

$T_{CASE} = -40$ to 125 °C, unless otherwise specified. $V_{SUP} = V_{SUP_UV_L}$ to 40 V, unless otherwise specified. All voltages referenced to ground. When 28 V $< V_{SUP} < 40$ V, thermal dissipation must be considered ([Figure 22](#)).

| Symbol | Parameter | Min | Typ | Max | Unit | Notes |
|--|--|----------|--------|--------|------|-------|
| V_{PRE} VOLTAGE PRE-REGULATOR | | | | | | |
| f _{SW_PRE} | V _{PRE} Switching Frequency | 418 | 440 | 462 | kHz | |
| t _{SW_PRE} | V _{SW_PRE} On and Off Switching Time | – | – | 30 | ns | (17) |
| t _{PRE_SOFT} | V _{PRE} Soft Start Duration (C _{OUT} ≤ 100 μF) | 500 | – | 700 | μs | |
| t _{PRE_BLK_LIM} | V _{PRE} Current Limitation Blanking Time | 200 | – | 600 | ns | |
| t _{PRE_OC} | V _{PRE} Overcurrent Filtering Time | 30 | – | 120 | ns | (17) |
| t _{PRE_UV} | V _{PRE} Undervoltage Filtering Time | 20 | – | 40 | μs | |
| t _{PRE_UV_4p3} | V _{PRE} Shut-off Filtering Time | 3.0 | – | 6.0 | μs | |
| d _{IPRE/DT} | V _{PRE} Load Regulation Variation | – | – | 25 | A/ms | (17) |
| t _{PRE_WARN} | V _{PRE} Thermal Warning Filtering Time | 30 | – | 40 | μs | |
| t _{PRE_TSD} | V _{PRE} Thermal Detection Filtering Time | 1.3 | – | – | μs | |
| t _{V_{SUP}_IPFF} | I _{PF} Input Voltage Filtering Time | 1.0 | – | 4.0 | μs | |
| t _{PRE_IPFF} | I _{PF} High Side Peak Current Filter Time | 100 | – | 300 | ns | |
| t _{LS_RISE/FALL} | LS Gate Voltage Switching Time (I _{OUT} = 300 mA) | – | – | 50 | ns | |
| V_{SENSE} VOLTAGE REGULATOR | | | | | | |
| t _{V_{SNS}_UV} | V _{SNS} Undervoltage Filtering Time | 1.0 | – | 3.0 | μs | |
| V_{CORE} VOLTAGE REGULATOR | | | | | | |
| t _{CORE_BLK_LIM} | V _{CORE} Current Limitation Blanking Time | 20 | – | 40 | ns | |
| f _{SW_CORE} | V _{CORE} Switching Frequency | 2.28 | 2.4 | 2.52 | MHz | |
| t _{SW_CORE} | V _{SW_CORE} On and Off Switching Time | 6.0 | – | 12 | ns | |
| V _{CORE_SOFT} | V _{CORE} Soft Start (C _{OUT} = 100 μF max) | – | – | 10 | V/ms | |
| t _{CORE_WARN} | V _{CORE} Thermal Warning Filtering Time | 30 | – | 40 | μs | |
| t _{CORE_TSD} | V _{CORE} Thermal Detection Filtering Time | 0.5 | – | – | μs | |
| V_{CCA} VOLTAGE REGULATOR | | | | | | |
| t _{CCA_LIM} | V _{CCA} Output Current Limitation Filter Time | 1.0 | – | 3.0 | μs | |
| t _{CCA_LIM_OFF1} t _{CCA_LIM_OFF2} | V _{CCA} Output Current Limitation Duration | 10 50 | – – | – – | ms | |
| t _{CCA_WARN} | V _{CCA} Thermal Warning Filtering Time | 30 | – | 40 | μs | |
| t _{CCA_TSD} | V _{CCA} Thermal Detection Filter Time (int. MOSFET) | 1.5 | – | – | μs | |
| dI _{LOAD} /dt | V _{CCA} Load Transient | – | 2.0 | – | A/ms | (17) |
| V _{CCA_SOFT} | V _{CCA} Soft Start (5.0 V and 3.3 V) | – | – | 50 | V/ms | |

Notes

17. Guaranteed by characterization.

Table 5. Dynamic Electrical Characteristics (continued)

$T_{CASE} = -40$ to 125 °C, unless otherwise specified. $V_{SUP} = V_{SUP_UV_L}$ to 40 V, unless otherwise specified. All voltages referenced to ground. When 28 V < V_{SUP} < 40 V, thermal dissipation must be considered (Figure 22).

| Symbol | Parameter | Min | Typ | Max | Unit | Notes |
|--------|-----------|-----|-----|-----|------|-------|
|--------|-----------|-----|-----|-----|------|-------|

V_{AUX} VOLTAGE REGULATOR

| | | | | | | |
|--|--|----------|--------|--------|------|------|
| t_{AUX_LIM} | V _{AUX} Output Current Limitation Filter Time | 1.0 | – | 3.0 | µs | |
| $t_{AUX_LIM_OFF1}$ $t_{AUX_LIM_OFF2}$ | V _{AUX} Output Current Limitation Duration | 10 50 | – – | – – | ms | |
| t_{AUX_TSD} | V _{AUX} Thermal Detection Filter Time | 1.5 | – | – | µs | |
| dl_{AUX}/dt | V _{AUX} Load Transient | – | 2.0 | – | A/ms | (18) |
| V_{AUX_SOFT} | V _{AUX} Soft Start (5.0 V and 3.3 V) | – | – | 50 | V/ms | |

5V-CAN VOLTAGE REGULATOR

| | | | | | | |
|----------------|--|-----|-----|-----|------|------|
| t_{CAN_LIM} | Output Current Limitation Filter Time | 2.0 | – | 4.0 | µs | |
| t_{CAN_TSD} | V _{CAN} Thermal Detection Filter Time | 1.0 | – | – | µs | |
| t_{CAN_UV} | V _{CAN} Undervoltage Filtering Time | 4.0 | – | 6.0 | µs | |
| t_{CAN_OV} | V _{CAN} Overvoltage Filtering Time | 100 | – | 200 | µs | |
| dl_{CAN}/dt | V _{CAN} Load Transient | – | 100 | – | A/ms | (18) |

FAIL-SAFE MACHINE VOLTAGE SUPERVISOR

| | | | | | | |
|----------------|--|-----|---|-----|----|--|
| t_{PRE_OV} | V _{PRE} Overvoltage Filtering Time | 128 | – | 234 | µs | |
| t_{CORE_UV} | V _{CORE} FB Undervoltage Filtering Time | 4.0 | – | 10 | µs | |
| t_{CORE_OV} | V _{CORE} FB Overvoltage Filtering Time | 128 | – | 234 | µs | |
| t_{CCA_UV} | V _{CCA} Undervoltage Filtering Time | 4.0 | – | 10 | µs | |
| t_{CCA_OV} | V _{CCA} Overvoltage Filtering Time | 128 | – | 234 | µs | |
| t_{AUX_UV} | V _{AUX} Undervoltage Filtering Time | 4.0 | – | 10 | µs | |
| t_{AUX_OV} | V _{AUX} Overvoltage Filtering Time | 128 | – | 234 | µs | |

MULTI-PURPOSE IOS

DIGITAL INPUT

| | | | | | | |
|--------------|-------------------------------|-----|---|-----|-----|--|
| F_{IO_IN} | Digital Input Frequency Range | 0.0 | – | 100 | kHz | |
|--------------|-------------------------------|-----|---|-----|-----|--|

ANALOG MULTIPLEXER

| | | | | | | |
|------------------|---|---|---|----|----|--|
| t_{MUX_READY} | SPI Selection to Data Ready to be Sampled on Mux_out • $V_{DDIO} = 5.0$ V, $C_{MUX_OUT} = 1.0$ nF | – | – | 10 | µs | |
|------------------|---|---|---|----|----|--|

INTERRUPT

| | | | | | | |
|----------------|-----------------------------|-----|---|---|----|--|
| t_{INTB_LG} | INTB Pulse Duration (long) | 100 | – | – | µs | |
| t_{INTB_ST} | INTB Pulse Duration (short) | 25 | – | – | µs | |

FUNCTIONAL SATE MACHINE

| | | | | | | |
|---------------|---|----|----|----|----|--|
| t_{WU_GEN} | General Wake-up Signal Deglitch Time (for IO wu signal) | 50 | 70 | 90 | µs | |
|---------------|---|----|----|----|----|--|

Notes

18. Guaranteed by characterization.

5 Functional Description

5.1 Introduction

The 33907_8 is the third generation of the System Basis Chip, combining:

- High efficiency switching voltage regulator for MCU, and linear voltage regulators for integrated CAN interface, external ICs such as sensors, and accurate reference voltage for A to D converters.
- Built in enhanced high speed CAN interface (ISO11898-2 and -5), with local and bus failure diagnostic, Protection and Fail-safe operation mode.
- Low power mode, with ultra low current consumption.
- Various wake-up capabilities
- Enhanced safety features with multiple fail-safe outputs and scheme.

5.2 Functional Pin Description

5.2.1 Power Supply(VSUP1, VSUP2, VSUP3)

VSUP1 and VSUP2 are the inputs pins for internal supply dedicated to SMPS regulators. VSUP3 is the input pin for internal voltage reference. VSUP1, 2, and 3 are robust against ISO7637 pulses.

5.2.2 VSENSE Input (VSENSE)

This pin must be connected to the battery line (before the reverse battery protection diode), via a serial resistor. It incorporates a threshold detector to sense the battery voltage, and provide a battery early warning. It also includes a resistor divider to measure the VSENSE voltage via the MUX-OUT pin. VSENSE pin is robust against ISO7637 pulse.

5.2.3 VCORE Output (1.2 V, 3.3 V)

On 33907 and 33908 product versions, the VCORE block is an SMPS regulator. The main difference between both versions is the current capability of the V_{CORE} regulator.

On 33907 and 33908 product versions, the voltage regulator is a step down DC-DC converter operating in voltage control mode. The output voltage is selectable (1.2 V or 3.3 V) through an external resistor divider connected between V_{CORE} and the feedback pin (FB_Core) ([Figure 1](#)). The stability of the converter is done externally, by using the COMP_Core pin.

5.2.4 VAUX OUTPUT, 5.0 V, 3.3 V Selectable

The VAUX pin provides an auxiliary output voltage (5.0 V, 3.3 V) selectable through an external resistor connected to SELECT pin. It uses an external PNP ballast transistor for flexibility and power dissipation constraints.

The VAUX output voltage regulator can be used as “sensor supply” (external ECU supply) or “auxiliary supply” (local ECU supply).

Overcurrent, overvoltage, and undervoltage detectors are provided.

V_{AUX} can be turned ON or OFF (if not configured as safety critical) via a SPI command. V_{AUX} overcurrent and overvoltage information disables V_{AUX} , reported in the dedicated register, and generates an Interrupt.

V_{AUX} is enabled by default.

5.2.5 VCCA Output, 5.0 V or 3.3 V Selectable

The VCCA voltage regulator is used to provide an accurate voltage output (5.0 V, 3.3 V) selectable through an external resistor connected to the SELECT pin.

The VCCA output voltage regulator can be configured using an internal ballast transistor delivering very good accuracy (+/- 1% for 5 V configuration and +/- 1.5% for 3.3 V configuration), with a limited current capability (100 mA) for an Analog to Digital converter, or with an external PNP transistor, giving higher current capability with lower output voltage accuracy when using a local ECU supply.

Overcurrent, overvoltage, and undervoltage detectors are provided.

VCCA can be turned ON or OFF (if not configured as safety critical) via a SPI command. VCCA overcurrent (with the use of external PNP only) and overvoltage information disables VCCA. Diagnostics are reported in the dedicated register and generate an Interrupt.

VCCA is enabled by default.

5.2.6 SELECT Input (VCCA, VAUX Voltage Configuration)

VCCA and VAUX output voltage configurations are set by connecting an external resistor between SELECT pin and Ground.

According to the value of this resistor, the voltage of VCCA and VAUX are configured after each Power On Reset, and after a wake-up event when device is in LPOFF. Information latches until the next hardware configuration read.

Regulator voltage values can be read on the dedicated register via the SPI.

Table 6. VCCA/VAUX Voltage Selection

| V _{CCA} (V) | V _{AUX} (V) | R Select | Recommended value |
|----------------------|----------------------|-----------------|-------------------|
| 3.3 | 3.3 | <7.0 KΩ | 5.1 KΩ ±5.0% |
| 5.0 | 5.0 | 10.8 << 13.2 KΩ | 12 KΩ ±5.0% |
| 3.3 | 5.0 | 21.6 << 26.2 KΩ | 24 KΩ ±5.0% |
| 5.0 | 3.3 | 45.9 << 56.1 KΩ | 51 KΩ ±5.0% |

When V_{AUX} is not used, the output V_{CCA} voltage configuration is set using an external resistor connected between the SELECT and the VPRE pin.

Table 7. VCCA Voltage Selection (VAUX not used)

| V _{CCA} (V) | R select | Recommended Value |
|----------------------|-----------------|-------------------|
| 3.3 | <7.0 KΩ | 5.1 KΩ ±5.0% |
| | 21.6 << 26.2 KΩ | 24 KΩ ±5.0% |
| 5.0 | 10.8 << 13.2 KΩ | 12 KΩ ±5.0% |
| | 45.9 << 56.1 KΩ | 51 KΩ ±5.0% |

5.2.7 Debug Input (Entering In Debug Mode)

The DEBUG pin allows the product to enter Debug mode.

To activate the Debug mode, voltage applied to the DEBUG pin must be within the V_{DEBUG_IL} and V_{DEBUG_IH} range at startup. If the voltage applied to DEBUG pin is out of these limits, before V_{CORE} ramp-up, the device settles into Normal mode.

When the Debug mode is activated, the FS0B output is asserted low at startup.

As soon as the FS0B is released to "high" via SPI (Good WD answer and FS_OUT writing) this pin is never activated whatever the fault is reported.

In debug mode, any errors from watchdog are ignored (No reset and No fail-safe), even if the whole functionality of the watchdog is kept ON (Seed, LFSR, Wd_refresh counter, WD error counter). This allows an easy debug of the hardware and software routines (i.e. SPI commands).

When the Debug mode is activated, the CAN transceiver is set to Normal operation mode. This allows communication with the MCU, in case SPI communication is not available (case of MCU not programmed).

To exit Debug mode, the pin must be tied to ground through an external pull-down resistor. A Power On Reset occurs.

5.2.8 5 V-CAN Voltage Regulator

5 V-CAN voltage regulator is a linear regulator fully dedicated to the internal HSCAN interface. An external capacitor is required. Overcurrent, overvoltage, and undervoltage detectors are provided. During overvoltage, the 5 V-CAN regulator switches off. Information is reported in the dedicated register and this generates an Interrupt. The 5 V-CAN regulator is enabled by default.

5.2.9 Multiplexer Output Mux_out

The MUX_OUT pin (Figure 7) delivers analog voltage to the MCU ADC input. The voltage to be delivered to MUX_OUT is selected via the SPI, from one of the following parameters:

- V_{SENSE}
- VIO_O
- VIO_1
- Internal 2.5 V reference
- Die temperature sensor T (°C) = $V_{mux_Out} * 165 / 2.15$

Voltage range at MUX_OUT is from GND to VDDIO (3.3 V or 5.0 V)

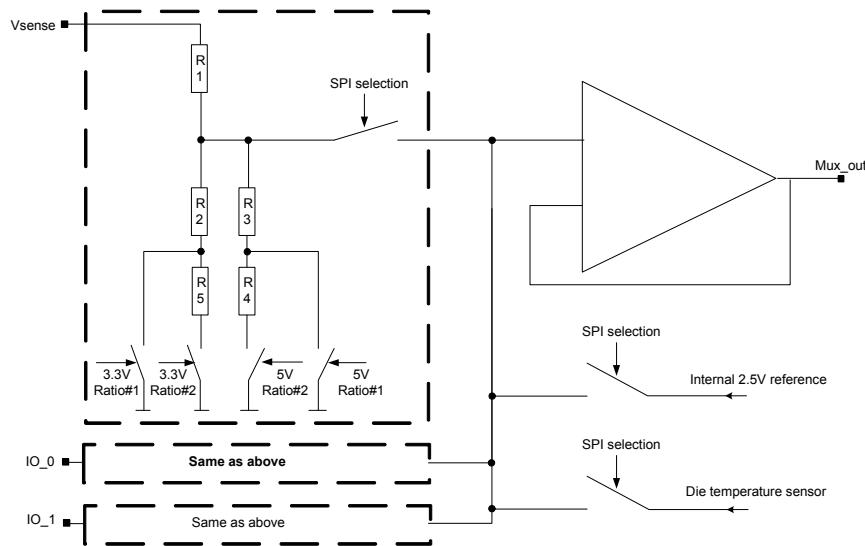

Figure 7. Simplified Analog Multiplexer Block Diagram

5.2.10 CANH, CANL, RXD, TXD

These are the pins of the high speed CAN physical interface.

The CAN interface is connected to the MCU via the RXD and TXD pins.

The HSCAN also exhibits wake-up capability with a very low current consumption.

5.2.11 INTERRUPT (INTB)

The INTB output pin generates a low pulse when an Interrupt condition occurs. The INTB behavior as well as the pulse duration are set through the SPI during INIT phase.

5.2.12 I/O pins (I/O_0:I/O_6)

The 33907_8 includes six multi-purpose I/Os (I/O_0 to I/O_5).

I/O_0, I/O_1, I/O_4, and I/O_5 are load dump proof and robust against ISO7637 pulses. An external serial resistor must be connected to those pins. I/O_2 and I/O_3 are not load dump proof.

Table 8. I/Os Configuration

| I/O Number | Analog Input | Digital Input | Wake-up Capability | Output Gate Driver |
|------------|--------------|---------------|--------------------|--------------------|
| IO_0 | X | X | X | |
| IO_1 | X | X | X | |
| IO_2 | | X | X | |
| IO_3 | | X | X | |
| IO_4 | | X | X | X |
| IO_5 | | X | X | X |

- IO_0:1 are selectable as follows:
 - Analog input (load dump proof) sent to the MCU through the MUX_OUT pin.
 - Wake-up input on the rising or falling edge or based on the previous state.
 - Digital input (logic level) sent to the MCU through the SPI.
 - Safety purpose:** Digital input (logic level) to perform an IC error monitoring (both IO_0 AND IO_1 are used if configured as safety inputs).
- IO_2:3 are selectable as follows:
 - Digital input (logic level) sent to the MCU through the SPI.
 - Wake-up input (logic level) on the rising or falling edge or based on the previous state.
 - Safety purpose:** Digital input (logic level) to monitor MCU error signals (both IO_2 AND IO_3 are used if configured as safety inputs).
 - Only bi-stable protocol is available.

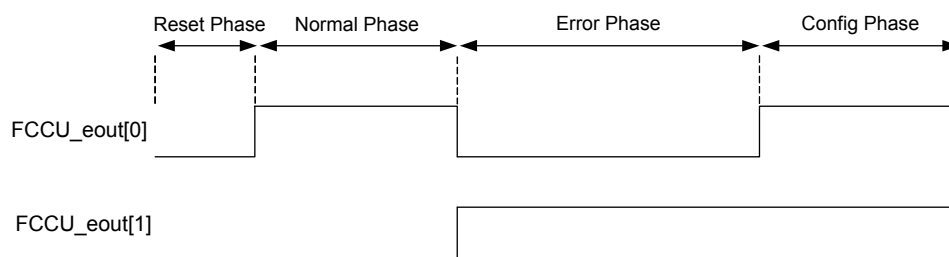

Figure 8. IO_2:3 MCU Error Monitoring: Bi-stable Protocol

- IO_4:5 are selectable as follows:
 - Digital input (logic level) sent to the MCU through the SPI.
 - Wake-up input (load dump proof) on rising or falling edge or based on previous state.
 - Output gate driver for LS logic level MOSFET.
 - Safety purpose:** Digital input (logic level) to perform an IC error monitoring (both IO_4 AND IO_5 are used if configured as safety inputs).

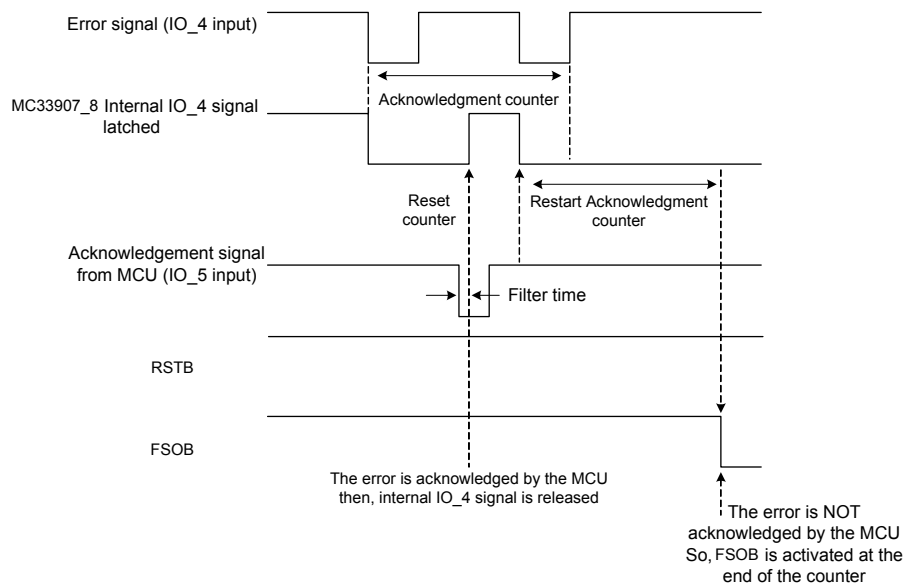

Figure 9. External Error Signal Handling

5.2.13 SAFE Output PINs (FS0B, RSTB)

FS0B is asserted low when a fault event occurs (See [Faults Triggering FS0B Activation on page 42](#)). The objective of this pin is to drive an electrical safe circuitry to deactivate the whole system and set the ECU in a protected and known state.

An external pull-up circuitry is mandatory connected to VDDIO or VSUP3. If pull-up is connected to VSUP3, the value of this pull-up must be above 10 kohm.

After each power on reset or after each wake-up event (LPOFF) the FS0B pin is asserted low. Then the MCU can decide to release the FS0B pin, when the application is ready to start.

The RSTB pin must be connected to MCU and is active low. An external pull-up resistor must be connected to VDDIO.

In default configuration, the RST delay time has three possible values depending of the mode and product configuration:

- The longest one is used automatically following a Power On Reset or when resulting from LPOFF mode (Low Power Off).
- The two reset durations are then available in the INIT_FSSM1 register, which are 1.0 ms and 10 ms. The configured duration is finally used in the normal operation when a fault occurs leading to a reset activation. The INIT_FSSM1 register is available (writing) in the INIT FS phase.

5.2.14 Pre-regulator (VPRE)

A highly flexible SMPS pre-regulator is implemented in the 33907_8. It can be configured as "Non-inverting Buck-boost converter" ([Figure 24](#)) or "Standard Buck converter" ([Figure 23](#)), depending of the external configuration (Low Side connection). The configuration is detected automatically during start-up sequence.

The SMPS pre-regulator is working in current mode control and the compensation network is fully integrated in the device. The high side switching MOSFET is also integrated to make the current control easier.

The pre-regulator delivers a voltage output of 6.5 V, which is used internally.

Overcurrent, overvoltage, and undervoltage detectors are provided.

6 Functional Device Operation

6.1 Mode and State Description of MAIN State Machine

The device has several operation modes. The transition and conditions to enter or leave each mode are illustrated in the functional state diagram ([Figure 10](#)). Two state machines are working in parallel. The Main state machine is in charge of the power management (V_{PRE} , V_{CORE} , V_{AUX} , V_{CCA} ,...) and the fail-safe state machine is in charge of all the safety aspect (WD, RSTB, FS0B,...).

6.1.1 Buck or Buck Boost Configuration

An external low side logic level MOSFET (N-type) is required to operate in “Non-inverting buck-boost converter”. The connection of the external MOSFET is detected automatically during the start-up phase.

If the low side is not connected (GATE_LS pin connected to PGND), the product is configured as a standard buck converter.

6.1.2 VPRE ON

Pre-regulator is an SMPS regulator. In this phase, the pre-regulator is switched ON and a softstart with a specified duration is started to control the V_{PRE} output capacitor charge.

6.1.3 Select Pin Configuration

This phase is detecting the required voltage level on V_{AUX} and V_{CCA} , according to resistor value connected between the SELECT pin and ground. If the SELECT pin is connected to V_{PRE} via the resistor, it disables the V_{AUX} regulator at start-up.

6.1.4 VCORE/VAUX/VCCA ON

In this stage, the three regulators are switched ON at the same time with a specified soft start duration.

6.1.5 INIT Main

This mode is automatically entered after the device is “Powered ON”. When RSTB is released, initialization phase starts where the device can be configured via the SPI.

During INIT phase, some registers can only be configured in this mode (refer to [Table 12](#) and [Table 13](#)). Other registers can be written in this mode, and also in Normal mode.

Once the INIT registers configurations are complete, a last register called “INIT INT” must be configured to switch to Normal mode. Writing data in this register (even same default values), automatically locks the INIT registers, and the product switches automatically to Normal mode in the Main state machine.

6.1.6 Normal

In this mode, all device functions are available. This mode is entered by a SPI command from the INIT phase by writing in the INIT INT register.

While in Normal mode, the device can be set to Low power mode (LPOFF) using secured SPI command.

6.1.7 Low Power Mode OFF - LPOFF Sleep

Entering in Low Power mode OFF - SLEEP is only available if the product is in Normal mode by sending a secured SPI command. In this mode, all the regulators are turned OFF and the MCU connected to V_{CORE} regulator is unpowered.

Once the 33907_8 is in LPOFF SLEEP, the device monitors external events to wake-up and leave the Low Power mode. The wake-up events can occur and depending of the device configuration from:

- CAN
- I/Os inputs

When a wake-up event is detected, the device starts the main state machine again by detecting the V_{PRE} configuration (BUCK or BUCK-BOOST), the wake-up source is reported to the dedicated SPI register, and the Fail-safe state machine is also restarted.

Finally, after the wake-up event, the regulators are turned ON and the MCU operation restarts, and the initialization phase is accessible again.

6.1.8 Low Power Mode OFF - LPOFF V_{PRE_UV}

LPOFF- V_{PRE_UV} is entered when the device is in the INIT or Normal mode, and if the V_{PRE} voltage level is passing the $V_{PRE_UV_L_4P3}$ threshold (4.3 V instead of 6.5 V) due to a problem on V_{PRE} .

As the device is in LPOFF, all the regulators are switched OFF. After 1.0 ms the device attempts to recover by switching ON the V_{PRE} again.

6.1.9 Low Power Mode OFF - LPOFF DEEP FS

LPOFF DEEP FS is entered during start-up if the Power On Reset of the Fail-safe machine is not rising and if the key is OFF. In this mode, all regulators are OFF and to exit this mode, a high level on IO_0 is required (often connected to key ON key OFF signal).

LPOFF DEEP FS is also entered if the RSTB pin is asserted low within 8.0 s.

6.2 Mode and State Description of Fail-safe State Machine

6.2.1 LBIST

Included in the fail-safe machine, the Logic Built In Self Test (LBIST) verifies the correct functionality of the FSSM at start-up. The fail-safe state machine is fully checked and if an issue is reported, the device does not start and the RSTB stays low to finally go in LPOFF DEEP FS.

LBIST is run at start-up and after each wake-up event when device is in LPOFF mode.

6.2.2 Select Pin Configuration

This phase detects the required voltage level on VAUX and VCCA, according to the resistor value connected between the SELECT pin and ground, in case VAUX is used or the SELECT pin and V_{PRE} , if VAUX is not used in the application.

This mode is the equivalent mode seen in the main state machine. Difference is in the fail-safe machine. This detection is used to internally set the UV/OV threshold on VCCA and VAUX for the voltage supervision.

6.2.3 ABIST

Included in the fail-safe machine, the Analog Built In Self Test (ABIST) verifies the correct functionality of the analog part of the device, like the voltage supervisor (overvoltage and undervoltage detection) and the fail-safe output feedback (RSTB and FS0B). The ABIST is run at start-up and after each wake-up event when device is in LPOFF mode.

6.2.4 Release RSTB

In this state, the device releases the RSTB pin.

6.2.5 INIT FS

This mode is automatically entered after the device is “powered on” and only if Built Self Tests (Logic and Analog) have been passed successfully. This INIT FS mode starts as soon as RSTB is released (means no “Activate RST” faults are present and no external reset is requested). Faults leading to an “Activate RST” are described in [Watchdog Refresh Counter](#).

In this mode, the device can be configured via the SPI within a maximum time of 256 ms, including first watchdog refresh.

Some registers can only be configured in this mode and is locked when leaving INIT FS mode (refer to [Table 12](#) and [Table 13](#)).

It is recommended, to configure first the device before sending the first WD refresh.

As soon as the first good watchdog refresh is sent by the MCU, the device leaves this mode and goes into Normal WD mode.

6.2.6 Normal WD is Running

In this mode, the device is now waits for a periodic watchdog refresh, coming from the MCU within a specific configured window timing.

Configuration of the watchdog window period can be set during INIT FS phase or in this mode.

This mode is exited if there are consecutive bad watchdog refreshes, or if there is an external reset request.

6.2.7 RST Delay

When the reset pin is asserted low by the device, a delay runs, to release the RSTB, if there is no more faults present.

The reset low duration time is configurable via the SPI in the INIT_FSSM1 register, which is accessible (writing) only in the INIT FS phase. All the sources of reset are available in the [Watchdog Refresh Counter](#).

6.3 Functional State Diagram

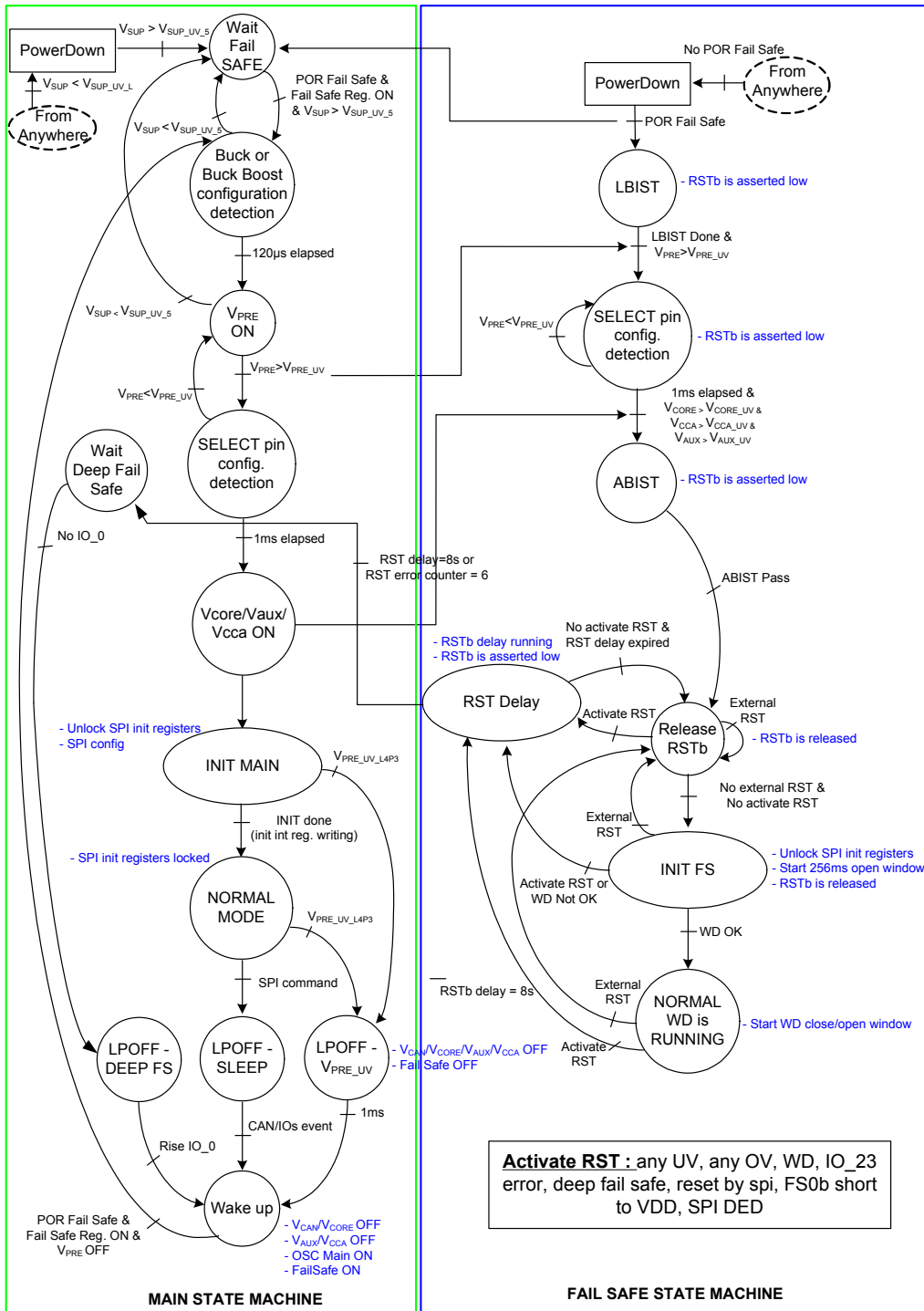

Figure 10. Simplified State Diagram

Archive Information

Archive Information

6.4 Fail-safe Machine

To fulfill safety critical applications, the 33907_8 integrates a dedicated Fail-safe machine (FSM). The FSM is composed of three main sub-blocks: the Voltage Supervisor (VS), the Fail-safe State Machine (FSSM), and the Fail-safe Output driver (FSO). The FSM is electrically independent from the rest of the circuitry, to avoid common cause failure.

For this reason, the FSM has its own voltage regulators (analog and digital), dedicated bandgap, and its own oscillator.

Three power supply pins (VSUP 1, 2, & 3) are used to overtake a pin lift issue. The internal voltage regulators are directly connected on VSUP (one bonding wire per pin is used). Additionally, the ground connection is redundant as well to avoid any loss of ground.

All the voltages generated in the device are monitored by the voltage supervisor (under & overvoltage) due to a dedicated internal voltage reference (different from the one used for the voltage regulators). The result is reported to the MCU through the SPI and delivered to the Fail-safe state machine (FSSM) for action. The FSSM has its own voltage regulator and oscillator. All the safety relevant signals feed the FSSM, which handles the error handling and controls the fail-safe outputs.

There are two fail-safe outputs: RSTB (asserted low to reset the MCU), and FS0B (asserted low to control any fail-safe circuitry).

The Fail-safe machine is in charge of bringing and maintaining the application in a fail-safe state. Four sub fail-safe states are implemented to handle the different kinds of failures, and to give a chance for the system to come back to a normal state.

6.5 Fail-safe Machine State Diagram

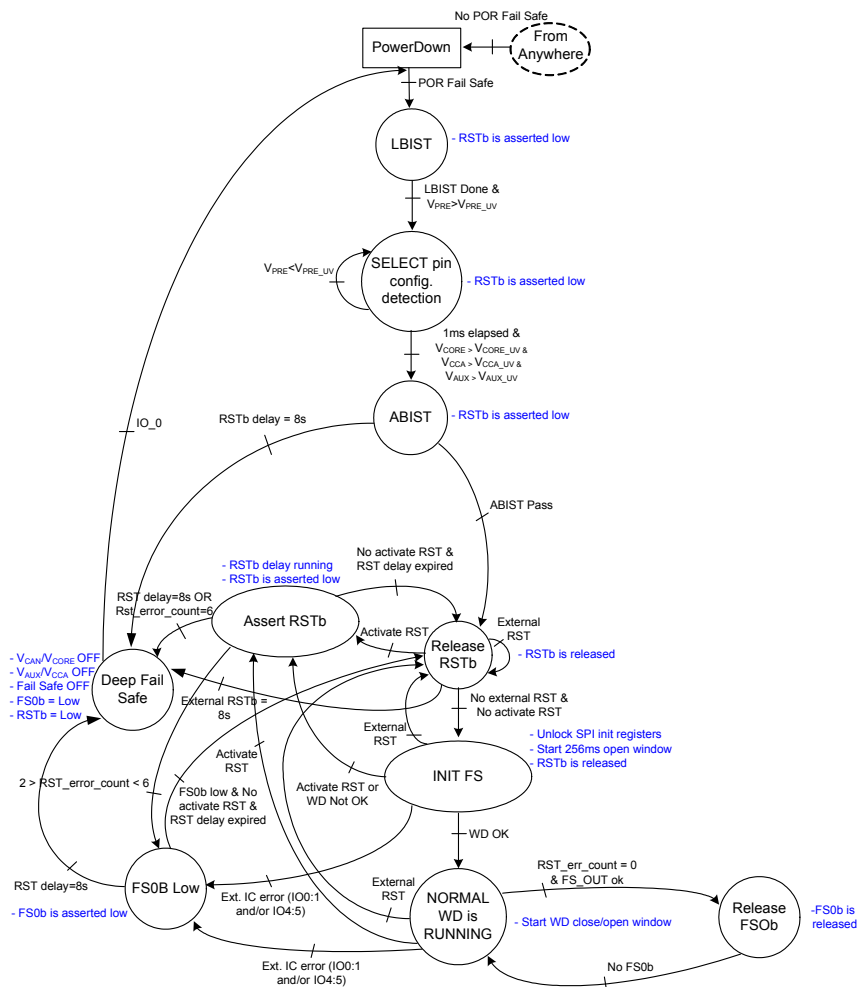

Figure 11. Simplified Fail-safe State Diagram

6.6 Watchdog Operation

A windowed watchdog is implemented in the PowerSBC and is based on "question/answer" principle. The watchdog must be continuously triggered by the MCU in the open watchdog window, otherwise an error is generated. The error handling and watchdog operations are managed by the Fail-safe state machine. For debugging purpose, this functionality can be inhibited by setting the right voltage on the DEBUG pin at start-up.

The watchdog window duration is selectable through the SPI during the INIT FS phase or in normal mode. The following values are available: 1.0 ms, 2.0 ms, 3.0 ms, 4.0 ms, 6.0 ms, 8.0 ms, 12 ms, 16.0 ms, 24 ms, 32 ms, 64 ms, 128 ms, 256 ms, 512 ms, 1024 ms. The watchdog can also be inhibited through the SPI register to allow "reprogramming" (ie.at vehicle level through CAN).

An 8-bit pseudo-random word is generated, due to a Linear Feedback Shift Register implemented in the PowerSBC. The MCU sends the seed of the LFSR during the INIT phase and then uses it to perform a pre-defined calculation. The result is sent through the SPI during the "open" watchdog window and verified by the PowerSBC. When the result is right, the LFSR is incremented and the watchdog window is restarted. When the result is wrong, the WD error counter is incremented, the watchdog window is restarted, and an INTB is generated. Any access to the WD register during the "closed" watchdog window is considered a wrong WD refresh.

6.6.1 Normal Operation (First Watchdog Refresh)

At power up, when the RSTB is released as high (after around 13 ms), the INIT phase starts for a maximum duration of 256 ms and this is considered as a fully open watchdog window. During this initialization phase the MCU sends the seed for the LFSR, or uses the default LFSR value generated by the PowerSBC (0xB2), available in the WD_LFSR register (Table 73).

Using this LFSR, the MCU performs a simple calculation based on this formula: the result of this calculation is based on the LFSR default value: 0x4D.

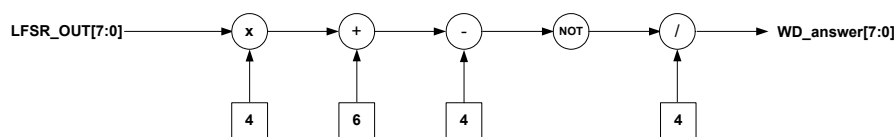

Figure 12. Watchdog Answer Calculation

The MCU sends the results in the WD answer register (Table 75).

When the watchdog is properly refreshed during the open window, the 256 ms open window is stopped and the initialization phase is finished. A new LFSR value is generated and available in the WD_LFSR register (Table 73).

If the watchdog refresh is wrong or if the watchdog is not refreshed during this 256 ms open window (INIT FS phase), the device asserts the reset low and the RSTB error counter is incremented by "1".

After a good watchdog refresh, the device enters the Normal WD refresh mode, where open and closed windows are defined either by the configuration made during initialization phase in the watchdog window register (Table 71), or by the default value already present in this register (3.0 ms).

6.6.2 Normal Watchdog Refresh

The watchdog must be refreshed during every open window of the window period configured in the register Table 71.

Any WD refresh restarts the window. This ensures the synchronization between MCU and PowerSBC.

The duration of the "window" is selectable through the SPI with no access restriction, means the window duration can be changed in the INIT phase or Normal mode. The duty cycle of the window is set to 50% and is not modifiable.

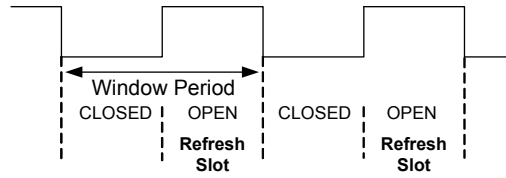

Figure 13. Windowed Watchdog

6.6.3 Watchdog in Debug Mode

When the device is in debug mode (entered via the DEBUG pin), the watchdog continues to operate, but does not affect the device operation by asserting a reset or fail-safe pins. For the user, operation appears without the watchdog. If needed and to debug the watchdog itself, the user can operate as in Normal mode and check LFSR values, the watchdog refresh counter, the watchdog error counter, and reset counter. This allows the user to debug their software and ensure a good watchdog strategy in the application.

6.7 Wrong Watchdog Refresh Handling

Error counters and strategy are implemented in the device to manage wrong watchdog refreshes from the MCU.

According to consecutive numbers of wrong watchdog refreshes, the device can decide to assert the RSTB only, or to go in deep fail-safe mode where only a Power On Reset or a transition on IO_O helps the system to recover.

6.7.1 Watchdog error counter

The watchdog error counter is implemented in the device to filter the incorrect watchdog refresh. Each time a watchdog failure occurs, the device increments this counter by 2. The WD error counter is decremented by 1 each time the watchdog is properly refreshed. This principle ensures that a cyclic “OK/NOK” behavior converges to a failure detection.

To allow flexibility in the application, the maximum value of this counter is configurable in the INIT_WD register, but only when device is in INIT FS mode.

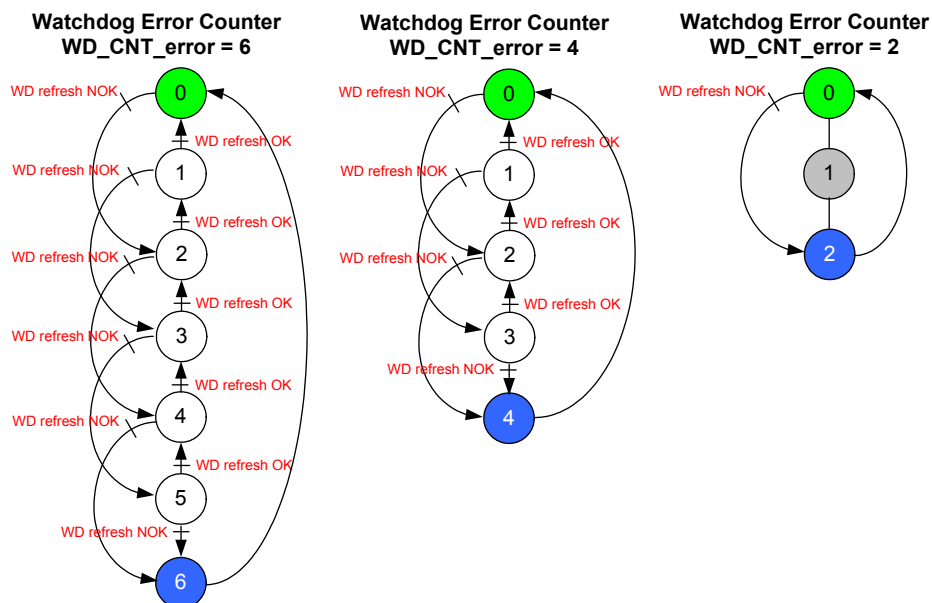

Figure 14. Watchdog Error Counter Configuration (Init_WD register, Bits WD_CNT_error_1:0)

6.7.2 Watchdog Refresh Counter

The watchdog refresh counter is used to decrement the RST error counter. Each time the watchdog is properly refreshed, the watchdog refresh counter is incremented by “1”.

Each time the watchdog refresh counter reaches “6” and if next WD refresh is also good, the RST error counter is decremented by “1” (case with WD_CNT_refresh_1:0 configured at 6).

Whatever the position is in the watchdog refresh counter, each time there is a wrong refresh watchdog, the watchdog refresh counter is reseted to “0”.

To allow flexibility in the application, the maximum value of this watchdog refresh counter is configurable in the INIT_WD register, but only when device is in INIT FS mode.

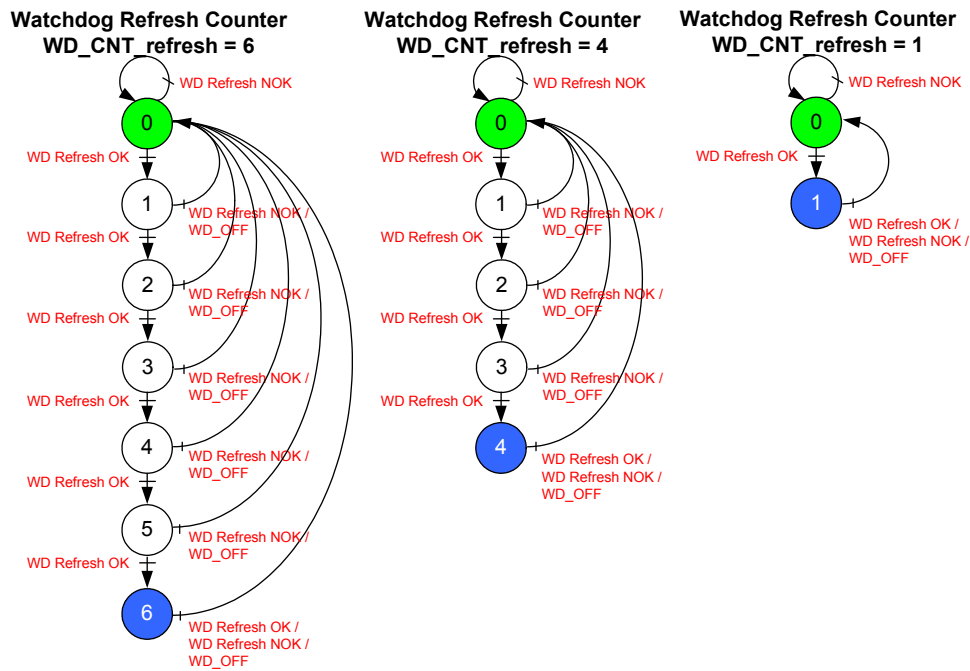

Figure 15. Watchdog Refresh Counter Configuration (Init_WD register, WD_CNT_refresh_1:0)

Table 9. Watchdog Error Table

| | | WINDOW | |
|-----|----------------|----------|--------|
| | | CLOSED | OPEN |
| SPI | BAD Key | WD_NOK | WD_NOK |
| | GOOD Key | WD_NOK | WD_OK |
| | None (timeout) | No_issue | WD_NOK |

Any access to the watchdog register during the “closed” watchdog window is considered as a wrong watchdog refresh. Watchdog timeout, meaning no WD refresh during closed or open windows, is considered as a wrong WD refresh.

6.7.3 Reset Error Counter

The reset error counter manages the reset events and counts the number of resets occurring in the application. This counter is incremented not only for the reset linked to consecutive wrong refresh watchdogs, but also for other sources of reset (undervoltage, overvoltage, external reset).

The RST error counter is incremented by 1, each time a reset is generated.

The reset error counter has two output values (intermediate and final). The intermediate output value is used to handle the transition from reset (RSTB is asserted low) to reset and fail where RSTB and FS0B are activated. The final value is used to handle the transition from reset and fail to deep reset and fail (Deep fail-safe mode), where regulators are off, reset and FS0B are activated, and a power on reset or a transition on IO_0 is needed to recover.

The intermediate value of the reset error counter is configurable to “1” or “3” using the RSTB_err_FS bit in the INIT FSSM2 register (Table 69).

If RSTB_err_FS is set to “0”, it means the device activates FS0B when the reset error counter reaches level “3”.

If RSTB_err_FS is set to “1”, it means the device activates FS0B when the reset error counter reaches level “1”.

This configuration must be done during INIT FS phase.

The final value of the reset error counter is based on the intermediate configuration.

- RSTB_err_FS = 0 / Intermediate = 3; Final = 6 (Figure 16). When reset error counter reaches 6, the device goes into deep reset and fails.
- RSTB_err_FS = 1 / Intermediate = 1; Final = 2 (Figure 17). When reset error counter reaches 2, the device goes into deep reset and fails.

In any condition, if the RSTB is asserted LOW for a duration longer than eight seconds, the device goes into deep reset and fails.

Conditions that leads to an incrementation of the RSTB error counter, and according to the product configuration are:

- Watchdog error counter = 6
- Watchdog refresh NOK during INIT phase or Watchdog timeout
- IO_23 error detection (FCCU)
- Undervoltage
- Overvoltage
- FS0B shorted to VDD
- SPI DED
- Reset request by the SPI
- External reset

Conditions leading to a transition go to FS, according to the product configuration are:

- IO_01/IO_23/IO_45 error detection
- Undervoltage
- Overvoltage
- Analog BIST fail
- SPI DED
- RSTB shorted to high

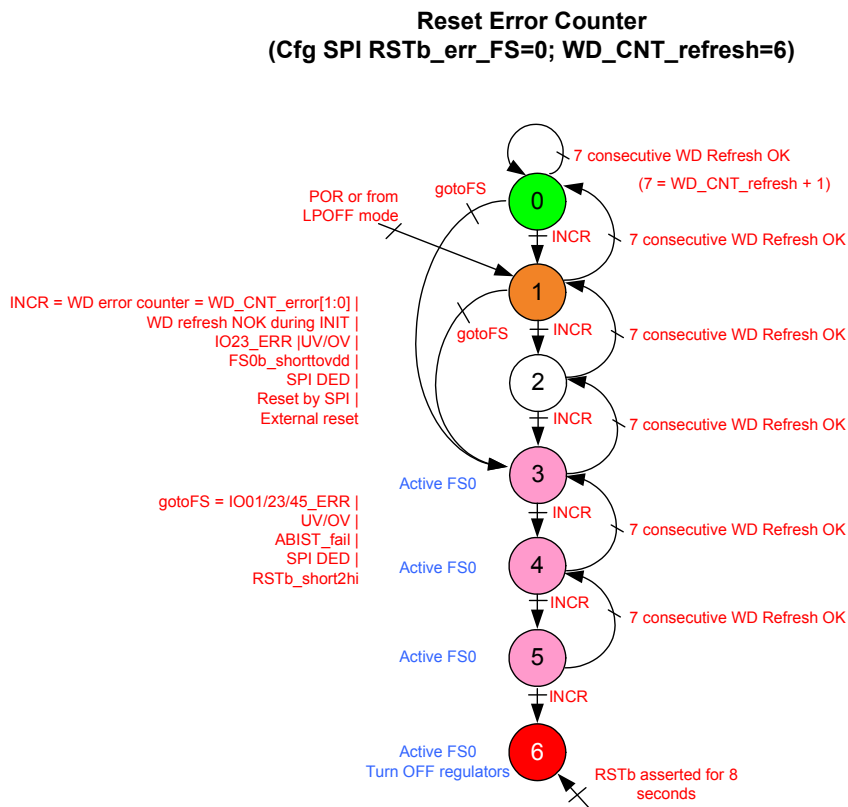

Reset Error Counter
(Cfg SPI RSTb_err_FS=1; WD_CNT_refresh=6)

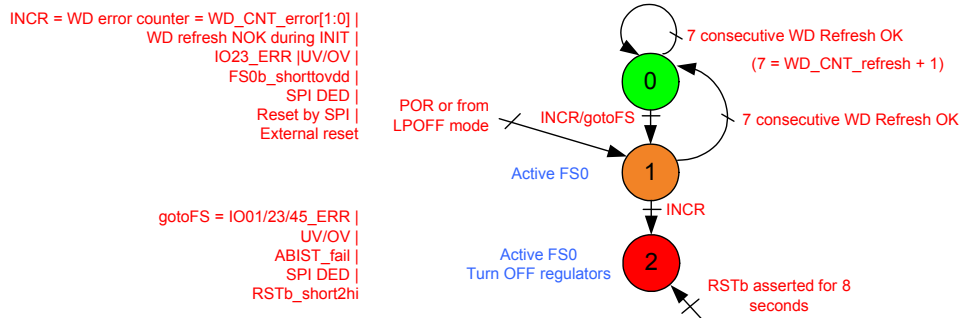

Figure 17. RSTB Error Counter(RSTb_err_FS = 1)

6.7.4 RST Error Counter at Start-up or Resuming from LPOFF Mode

At start-up or when resuming from LPOFF mode the reset error counter starts at level 1 and FS0B is asserted low. To remove activation of FS0B, the RST error counter must go back to value “0” (seven consecutive good watchdog refresh decreases the reset error counter down to 0) and a right command is sent to FS_OUT register (Figure 20).

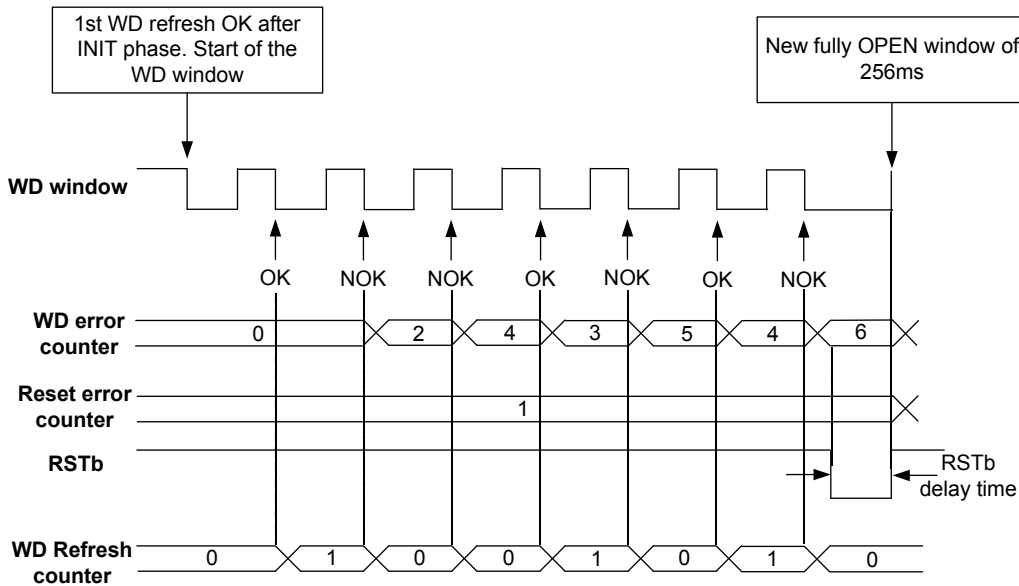

Figure 18. Example of WD Operation Generating a Reset (WD_error_cnt = 6)

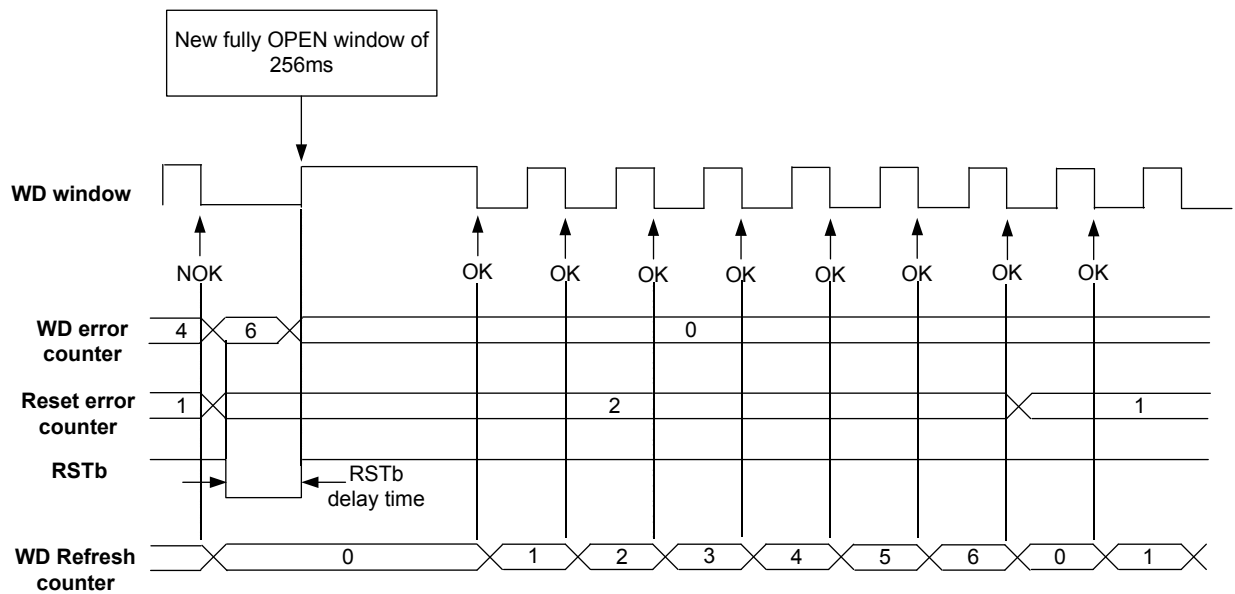

Figure 19. Example of WD Operation Leading a Decrement of the Reset Error Counter (WD_refresh_cnt = 6)

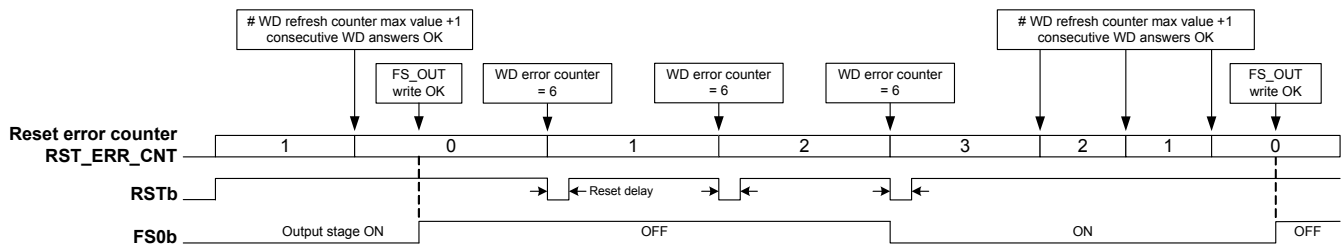

Figure 20. Reset Error Counter and FS0B DEACTIVATION Sequence (RSTB_err_FS = 0 & WD_CNT_error1:0 = 6)

6.7.5 Fail-safe Output (FS0B) De-activation

When the fail-safe output FS0B is asserted low by the device due to a fault, some conditions must be validated before allowing the FS0B pin to be de-activated by the device.

These conditions are:

- Fault is removed
- Reset error counter must be at "0"
- FS_OUT register must be filled with the right value.

6.7.6 Faults Triggering FS0B Activation

The activation of the FS0B is clearly dependent on the product configuration, but the following items can be settled:

- IO_01/IO_23/IO_45 error detection
- Undervoltage
- Overvoltage
- Analog BIST fail (not configurable)
- SPI DED (not configurable)
- RSTB shorted to high (not configurable)
- RSTB error counter level

6.7.7 SPI DED

Some SPI registers affect some safety critical aspects of the fail-safe functions, and thus are required to be protected against SEU (Single Event Upset). Only fail-safe registers are concerned.

During INIT FS mode, access to fail-safe registers for product configuration is open. Then once the INIT FS phase is over, the Hamming circuitry is activated to protect registers content.

At this stage, if there is 1 single bit flip, the detection is made due to hamming code, and the error is corrected automatically (fully transparent for the user), and a flag is sent. If there are two errors (DED - Dual Error Detection), the detection is made due to hamming code but detected errors cannot be corrected. Flag is sent, RSTB and FS0B are activated.

6.7.8 FS_OUT Register

When fault is removed and reset error counter changes back to level "0", a right word must be filled in the FS_OUT register. The value is dependant on the current WD_LFSR.

LSB and MSB must be swapped and negative operation per bit must be applied.

| | | | | | | | | |
|--------------|-----------------|-----------------|-----------------|-----------------|-----------------|-----------------|-----------------|-----------------|
| WD_LFSR_7:0= | b7 | b6 | b5 | b4 | b3 | b2 | b1 | b0 |
| FS_OUT_7:0 = | $\overline{b0}$ | $\overline{b1}$ | $\overline{b2}$ | $\overline{b3}$ | $\overline{b4}$ | $\overline{b5}$ | $\overline{b6}$ | $\overline{b7}$ |

Figure 21. FS_OUT Register Based on LFSR Value

6.7.9 INPUT VOLTAGE RANGE

Due to the flexibility of the pre-regulator, the device can cover a wide battery input voltage range. However, a more standard voltage range can still be covered using only the Buck configuration.

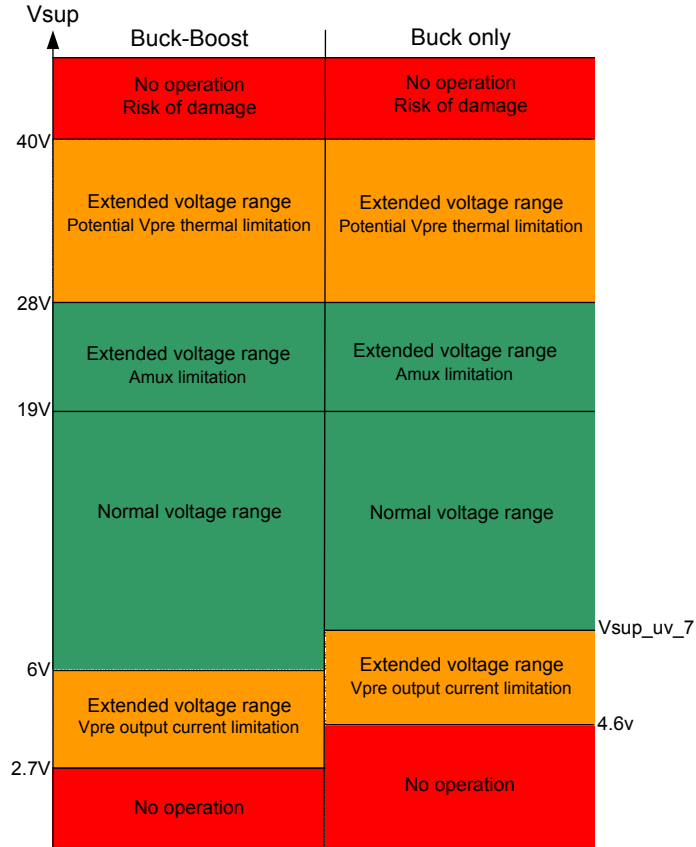

Figure 22. Input Voltage Range

- $V_{SUP} > 28\text{ V}$: Potential V_{PRE} thermal limitation
RDSON, Current limitation and Overcurrent detection are specified for $V_{SUP} < 28\text{ V}$
- $V_{SUP} < 19\text{ V}$: Mux_out limitation
IO_0 and IO_1 maximum analog input voltage range is 19 V
Internal 2.5 V reference voltage accuracy degraded
- Buck only, $V_{SUP} < V_{SUP_UV_7}$:
CAN communication is guaranteed for $V_{SUP} > 6.0\text{ V}$
For V_{CCA} and V_{AUX} 5.0 V configuration, under voltage triggers at low V_{SUP} (refer to $V_{CCA_UV_5}$ and $V_{AUX_UV_5}$)

6.7.10 V_{pre} Voltage Pre-regulator

A highly flexible SMPS pre-regulator is implemented in the 33907_8. Depending on the input voltage requirement, the device can be configured as “Non-inverting Buck-boost converter” (Figure 24) or “Standard Buck converter” (Figure 23). An external low side MOSFET (N-type) is required to operate in “Non-inverting Buck-boost converter”. The connection of the external MOSFET is detected automatically during the start-up phase.

The converter operates in Current Control mode in any configuration. The high side switching MOSFET is integrated to make the current control easier. The PWM frequency is fixed at 440 kHz typical. The compensation network is fully integrated. The output voltage (V_{PRE}) is regulated between 6.0 V and 7.0 V.

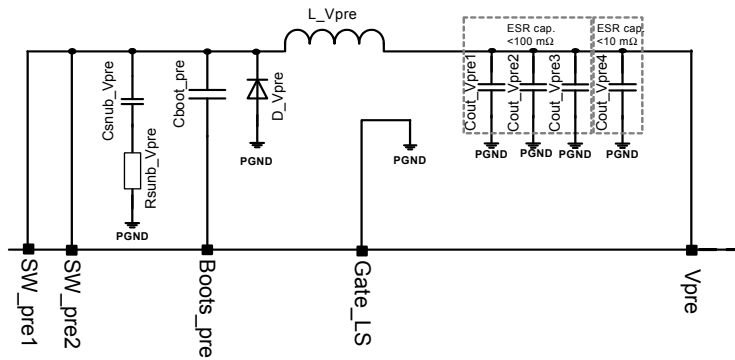

Figure 23. Pre-regulator: Buck configuration

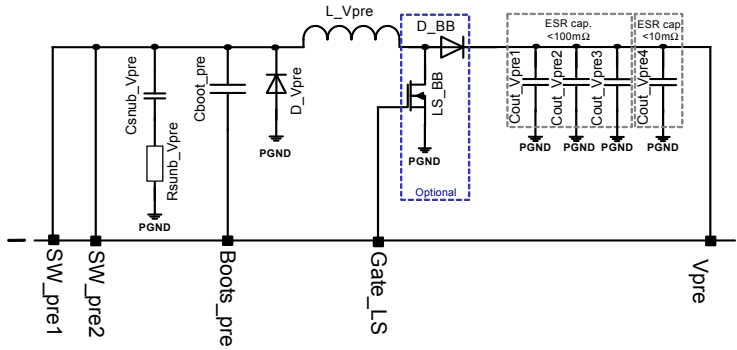

Figure 24. Pre-regulator: Buck Boost configuration

Transition between buck mode and boost mode is based on hysteresis (Figure 25).

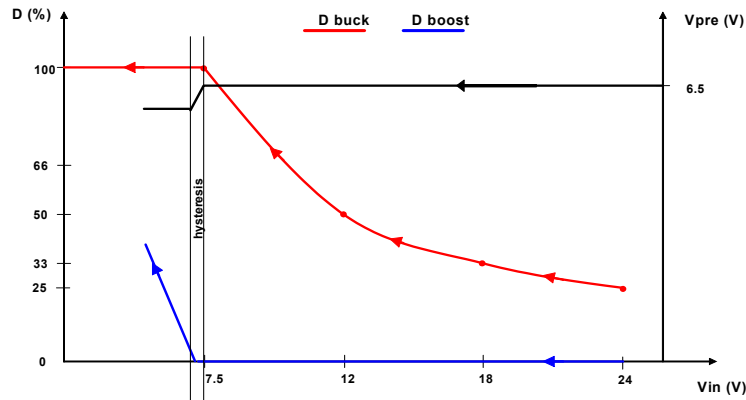

Figure 25. Transition between Buck and Boost

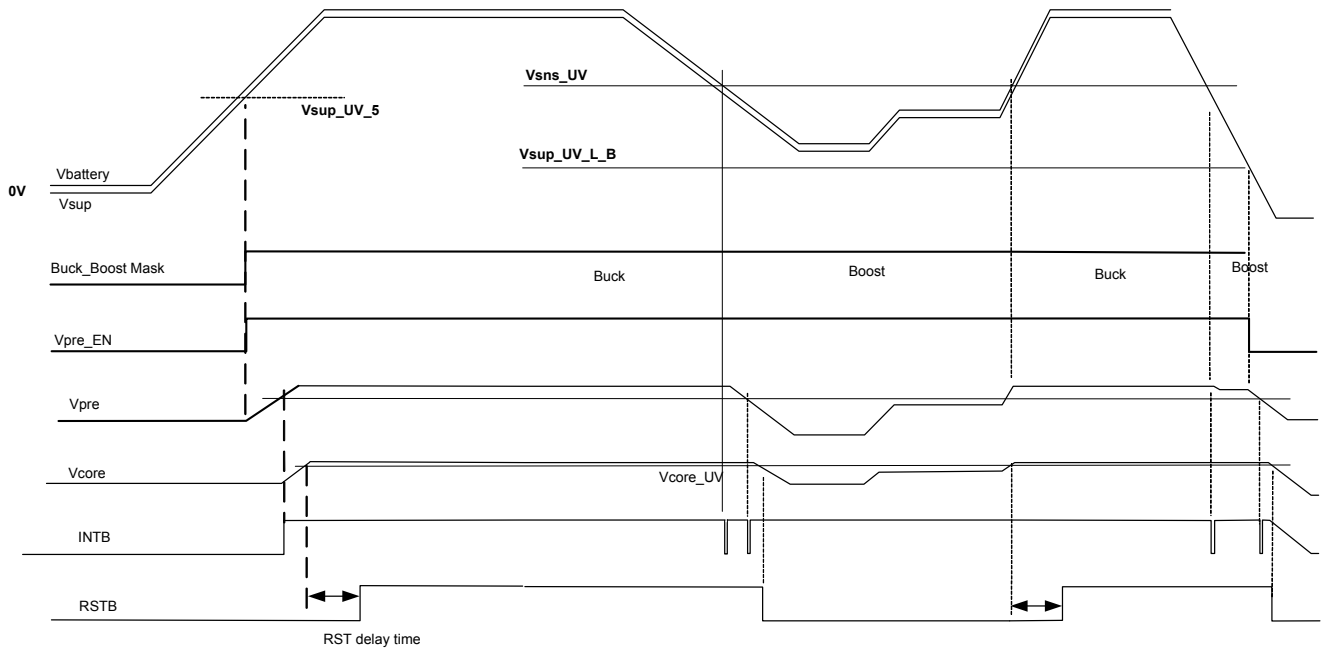

Figure 26. Buck Configuration Power-up and Power-down

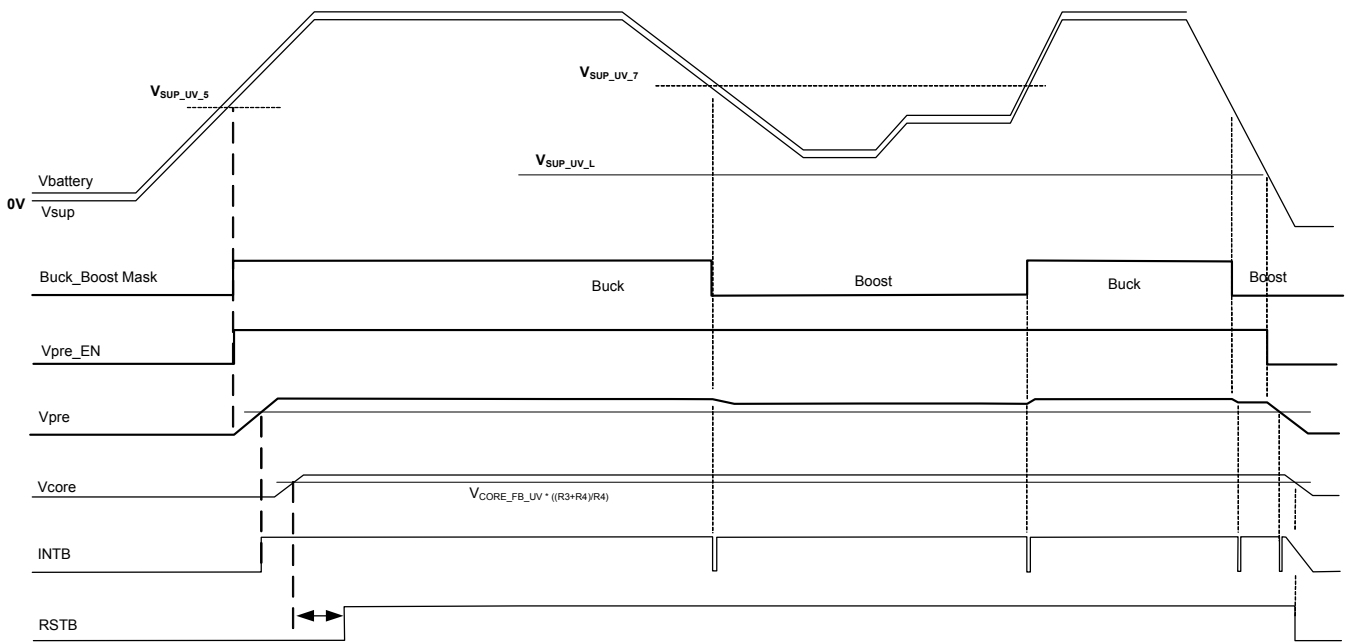

Figure 27. Buck Boost Configuration Power-up and Power-down

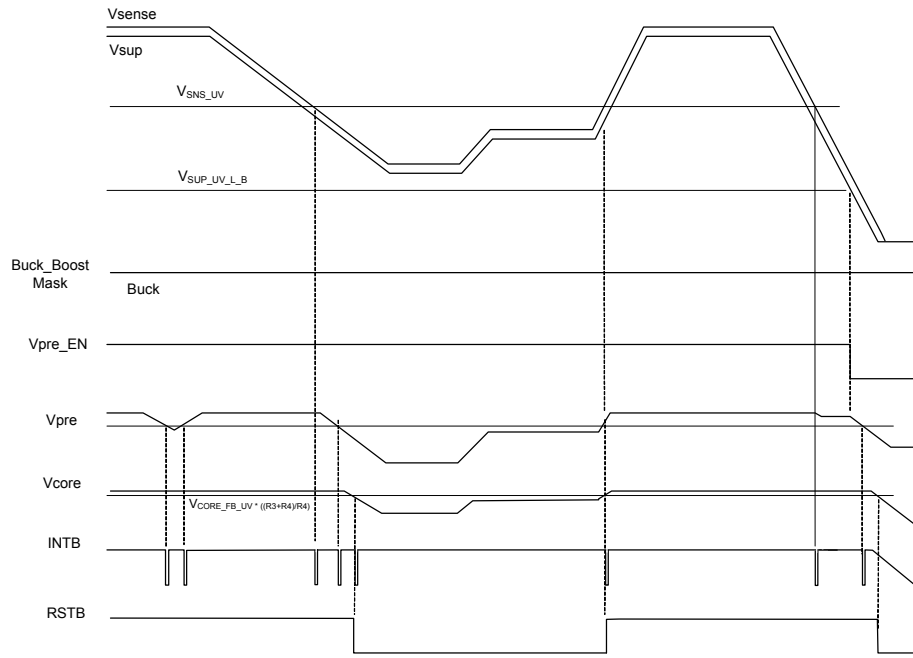

Figure 28. Behavior During a Cranking (Buck Configuration)

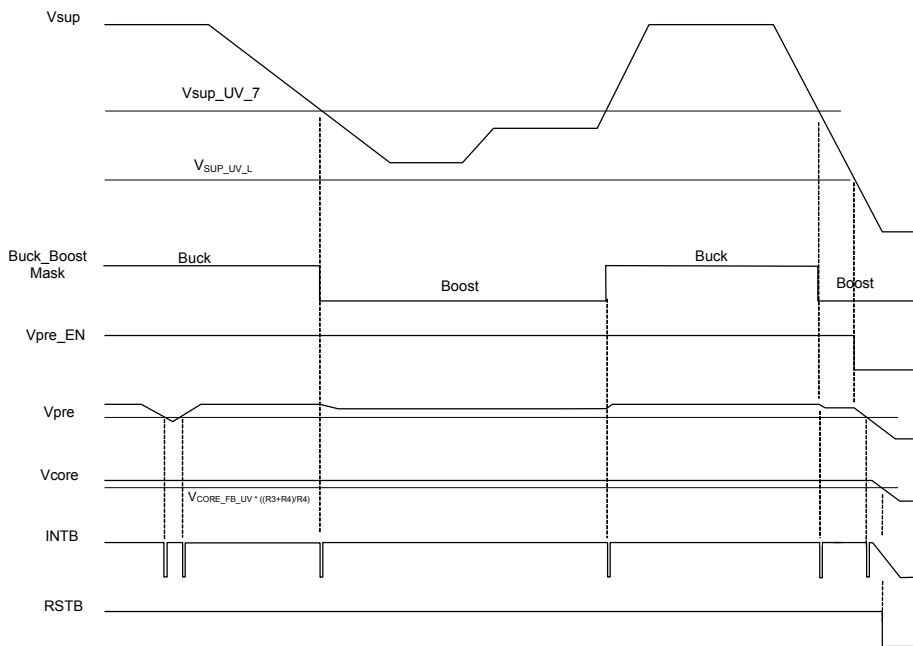

Figure 29. Behavior During a Cranking (Buck Boost Configuration)

In order to improve the efficiency, the converter switches automatically to burst mode in light load condition. Moreover, the battery voltage sensing (V_{SENSE}) is used to manage the load dump condition. An input power feed forward function is also implemented to minimize the switching losses during the load dump.

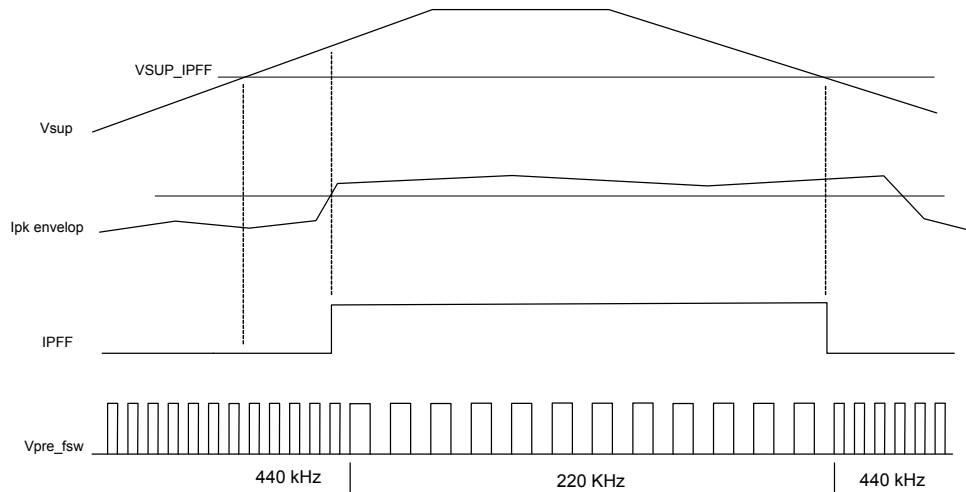

Figure 30. Input Power Feed Forward Principle

6.7.11 V_{core} Voltage Regulator

This voltage regulator is a step-down DC-DC converter operating in Voltage Control mode. The switching MOSFET is integrated. The PWM frequency is fixed at 2.4 MHz typical. The high side MOSFET is integrated in the device. The output voltage is configured for 1.2 V and 3.3 V, due to an external resistor divider connected between V_{CORE} and the feedback pin (FB-CORE) (Figure 34). The expected accuracy is $\pm 2.0\%$. The output current is up to 0.8 A for the 33907 and 1.5 A for the 33908 device. The stability of the overall converter is done externally by the pin COMP_CORE.

In order to improve the efficiency, the converter switches automatically in burst mode in light load condition.

6.7.12 Charge Pump and Bootstrap

Both switching MOSFETs of V_{PRE} and V_{CORE} SMPS are driven by external bootstrap capacitors. Additionally, a charge pump is implemented to ensure 100% duty cycle for both converters. Each converter uses a 100 nF external capacitor minimum to operate properly.

6.7.13 V_{CCA} Voltage Regulator

V_{CCA} is a linear voltage regulator mainly dedicated to supply the MCU I/Os, especially the ADC. The output voltage is selectable at 5.0 V or 3.3 V. Since this output voltage can be used to supply MCU I/Os, the output voltage selection is done using an external resistor connected to the SELECT pin and ground if V_{AUX} is used. When V_{AUX} is not used, the resistor is connected between the SELECT pin and V_{PRE} .

The expected accuracy is $\pm 1\%$ for 5 V configuration and $\pm 1.5\%$ for 3.3 V configuration with an output current capability at 100 mA.

An external PNP transistor is used to boost the current capability up to 300 mA. When an external PNP is used, the connection is detected automatically during the start-up sequence of the PowerSBC. In such condition, the internal pass transistor is switched OFF and all the current is driven through the external PNP to reduce the internal power dissipation. The output voltage accuracy with an external PNP is reduced to $\pm 3.0\%$. The V_{CCA} output voltage is used as a reference for the Auxiliary voltage supply (V_{AUX}) when used as sensor supply output.

6.7.14 V_{AUX} Voltage Regulator

V_{AUX} is a highly flexible linear voltage regulator either as an auxiliary supply dedicated to additional device in the ECU or as a sensor supply (i.e. outside the ECU). As an auxiliary supply, the output voltage is selectable between 5.0 V, 3.3 V. Since this voltage rail can be used to supply IOs, the selection is done with an external resistor connected between the SELECT pin and ground.

In such case, the expected accuracy is $\pm 3.0\%$. The output current capability is up to 300 mA. An external PNP transistor must be used (no internal current capability).

As a sensor supply rail, the output voltage is selectable between 5.0 V and 3.3 V.

Moreover V_{CCA} can be used as reference for the sensor supply used as tracker. The selection is also done during the INIT phase and secured. The tracking accuracy is expected to be ± 15 mV.

6.8 Startup Sequence

In order to provide a safe and well known startup sequence, the 33907_8 includes an undervoltage lock-out. This undervoltage lock-out is only applicable when the device is under a Power-On-Reset condition, which means the initial condition is $V_{SUP} < V_{SUP_UV_L}$ (i.e. below 2.7 V max). In all the other conditions (i.e. LPOFF), the device is able to operate (and therefore to (re)start) down to $V_{SUP_UV_L}$. The other different voltage rails automatically start, as described in the following figure.

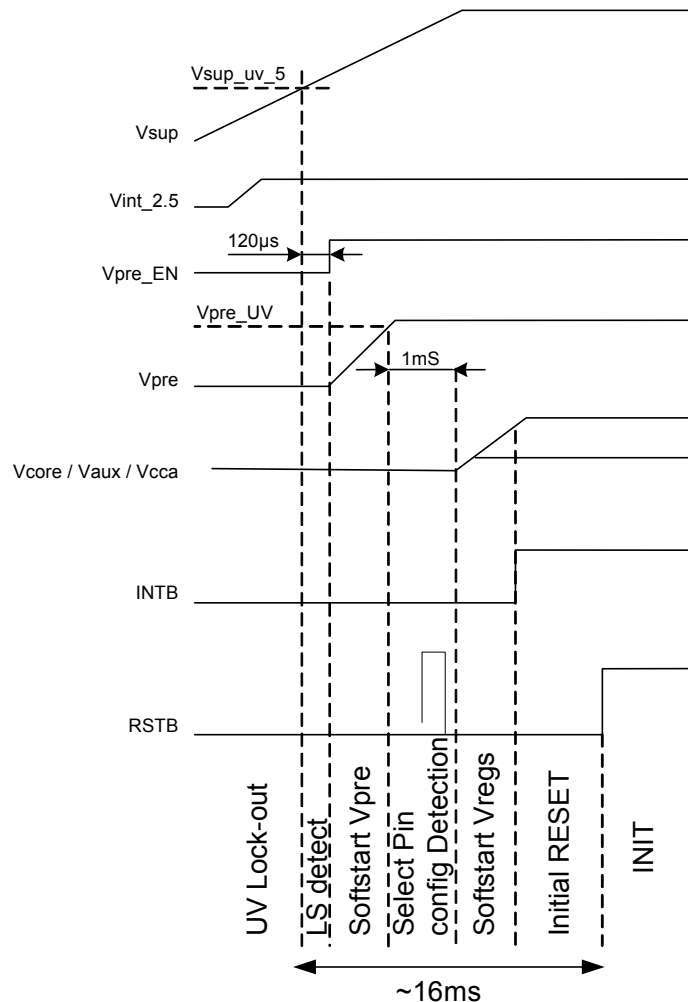

Figure 31. Start-up Scheme

The final value of V_{AUX} and V_{CCA} depends on the hardware configuration (resistor values on the SELECT pin). It takes around 13 ms to release the RSTB. RSTB can be pulled low after those 13 ms by the MCU, if it is not ready to run after power up.

7 Serial Peripheral Interface

7.1 High Level Overview

7.1.1 SPI

The device is using a 16 bits SPI, with the following arrangement:

MOSI, Master Out Slave In bits:

- Bit 15 read/write
- Bit 14 Main or fail-safe register target
- bit 13 to 9 (A4 to A0) to select the register address. Bit 8 is a parity bit in write mode, Next bit (=0) in read mode.
- bit7 to 0 (D7 to D0): control bits

MISO, Master IN Slave Out bits:

- bits 15 to 8 (S15 to S8) are device status bits
- bits 7 to 0(Do7 to Do0) are either extended device status bits, device internal control register content or device flags.

[Figure 32](#) is an overview of the SPI implementation.

7.1.2 Parity Bit 8 Calculation:

The parity is used for write to register command (bit 15,14 = 01). It is calculated based on the number of logic ones contained in bits 15-9,7-0 sequence (this is the whole 16 bits of the write command except bit 8).

Bit 8 must be set to 0 if the number of 1 is odd.

Bit 8 must be set to 1 if the number of 1 is even.

7.1.3 Device Status on MISO

When a write operation is performed to store data or control bit into the device, MISO pin reports a 16 bit fixed device status composed of 2 bytes: Device Fixed Status (bits 15 to 8) + extended Device Status (bits 7 to 0). In a read operation, MISO reports the fixed device status (bits 15 to 8), and the next 8 bits are content of the selected register. A standard serial peripheral interface (SPI) is integrated to allow bi-directional communication between the 33907_8 and the MCU. The SPI is used for configuration and diagnostic purposes.

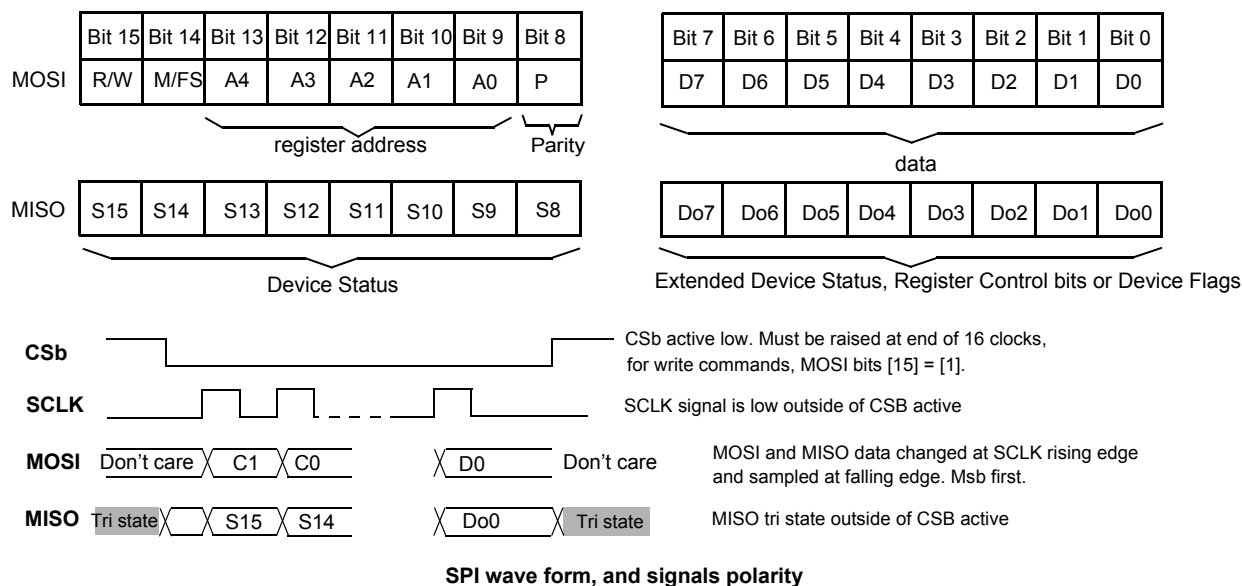

Figure 32. SPI Overview

The device contains several registers. Their address is coded on 7 bits (bits 15 to 9). Each register controls or reports part of the device function. Data can be written to the register, to control the device operation or set default value or behavior. Every register can also be read back in order to ensure that its content (default setting or value previously written) is correct.

7.1.4 Register Description

Although the minimum time between two NCS low sequences is defined by t_{ONNCS} (Figure 33), two consecutive accesses to the fail-safe registers must be done with a 3.5 μ s minimum NCS high time in between.

Although the minimum time between two fail-safe registers accesses is 3.5 μ s, some SPI accesses to the main registers can be done in between (Figure 34)

7.2 Detail Operation

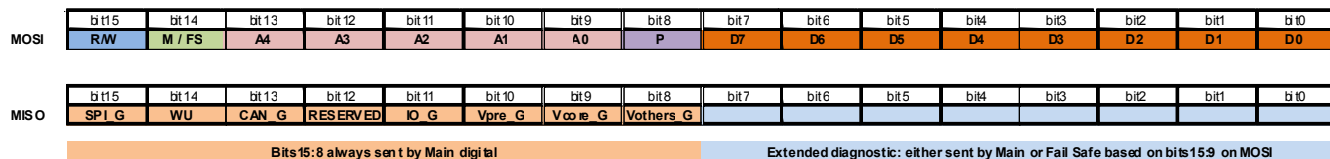

Figure 33. MOSI / MISO SPI Command Organization

Table 10. MOSI Bits Description

| | | |
|--------|-------------|--|
| R / W | Description | Set if it is a READ or WRITE Command |
| | 0 | READ |
| | 1 | WRITE |
| M / FS | Description | Split the addresses between Fail-safe State machine and Main Logic |
| | 0 | Main |
| | 1 | Fail-safe |
| A4:0 | Description | Set the address to Read or Write |
| | 0 | See Register Mapping |
| | 1 | |
| P | Description | Parity bit (only use in Write mode). Set to 0 in Read mode |
| | 0 | Number of "1" (bit15:9 and bit 7:0) is odd |
| | 1 | Number of "1" (bit15:9) and bit 7:0) is even |
| D7:0 | Description | Data in Write mode. Shall be set to 00h in Read mode |
| | 0 | See register details |
| | 1 | |

Table 11. MISO Bits Description

| | | |
|--------|-----------------|---|
| SPI_G | Description | Report an error in the SPI communication |
| | 0 | NO Failure |
| | 1 | Failure |
| | Reset Condition | Power On Reset / When initial event cleared on read |
| WU | Description | Report a wake-up event. Logical OR of ALL wake-up sources |
| | 0 | NO WU event |
| | 1 | WU event |
| | Reset Condition | Power On Reset / When initial event cleared on read |
| CAN_G | Description | Report a CAN event (Diagnostic) |
| | 0 | NO event |
| | 1 | CAN event |
| | Reset Condition | Power On Reset / When initial event cleared on read |
| IO_G | Description | Report a change in IOs state |
| | 0 | NO IO transition |
| | 1 | IO transition |
| | Reset Condition | Power On Reset / When initial event cleared on Read |
| VPRE_G | Description | Report an event from Vpre-regulator and battery monitoring (Status change or failure) |
| | 0 | NO event |
| | 1 | Event occurred |
| | Reset Condition | Power On Reset / When initial event cleared on Read |

Table 11. MISO Bits Description (continued)

| | | |
|------------|-----------------|--|
| V_CORE_G | Description | Report an event from V _{CORE} regulator (Status change or failure) |
| | 0 | NO event |
| | 1 | Event occurred |
| | Reset Condition | Power On Reset / When initial event cleared on Read |
| V_OTHERS_G | Description | Report an event from V _{CCA} , V _{AUX} , or V _{CAN} regulators (Status change or failure) |
| | 0 | NO event |
| | 1 | Event occurred |
| | Reset Condition | Power On Reset / When initial event cleared on Read |

7.2.1 Register Address Table

Table 12 is a list of device registers and addresses coded in bits 13 to 9 in MOSI for main logic.

Table 12. Register Mapping of Main Logic

| Register | Address | | | | | | | Write description | Table Ref |
|---------------|---------|----|----|----|----|----|----------|--|-----------|
| | FS/M | A4 | A3 | A2 | A1 | A0 | Hex | | |
| NOT USED | 0 | 0 | 0 | 0 | 0 | 0 | #0(00h) | N/A | N/A |
| INIT Vreg 1 | 0 | 0 | 0 | 0 | 0 | 1 | #1(01h) | Write during INIT phase then read only | Table 15 |
| INIT Vreg2 | 0 | 0 | 0 | 0 | 1 | 0 | #2(02h) | Write during INIT phase then read only | Table 17 |
| INIT CAN | 0 | 0 | 0 | 0 | 1 | 1 | #3(03h) | Write during INIT phase then read only | Table 19 |
| INIT IO_WU1 | 0 | 0 | 0 | 1 | 0 | 0 | #4(04h) | Write during INIT phase then read only | Table 21 |
| INIT IO_WU2 | 0 | 0 | 0 | 1 | 0 | 1 | #5(05h) | Write during INIT phase then read only | Table 23 |
| INIT INT | 0 | 0 | 0 | 1 | 1 | 0 | #6(06h) | Write during INIT phase then read only | Table 25 |
| NOT USED | 0 | 0 | 0 | 1 | 1 | 1 | #7(07h) | N/A | N/A |
| HW Config | 0 | 0 | 1 | 0 | 0 | 0 | #8(08h) | Read only | Table 27 |
| WU source | 0 | 0 | 1 | 0 | 0 | 1 | #9(09h) | Read only | Table 29 |
| NOT USED | 0 | 0 | 1 | 0 | 1 | 0 | #10(0Ah) | N/A | N/A |
| IO_input | 0 | 0 | 1 | 0 | 1 | 1 | #11(0Bh) | Read only | Table 31 |
| Status Vreg#1 | 0 | 0 | 1 | 1 | 0 | 0 | #12(0Ch) | Read only | Table 33 |
| Status Vreg#2 | 0 | 0 | 1 | 1 | 0 | 1 | #13(0Dh) | Read only | Table 35 |
| Diag Vreg#1 | 0 | 0 | 1 | 1 | 1 | 0 | #14(0Eh) | Read only | Table 37 |
| Diag Vreg#2 | 0 | 0 | 1 | 1 | 1 | 1 | #15(0Fh) | Read only | Table 39 |
| Diag Vreg#3 | 0 | 1 | 0 | 0 | 0 | 0 | #16(10h) | Read only | Table 41 |
| Diag CAN1 | 0 | 1 | 0 | 0 | 0 | 1 | #17(11h) | Read only | Table 43 |
| Diag CAN2 | 0 | 1 | 0 | 0 | 1 | 0 | #18(12h) | Read only | Table 45 |
| Diag SPI | 0 | 1 | 0 | 0 | 1 | 1 | #19(13h) | Read only | Table 48 |
| NOT USED | 0 | 1 | 0 | 1 | 0 | 0 | #20(14h) | N/A | N/A |

Table 12. Register Mapping of Main Logic

| Register | Address | | | | | | | Hex | Write description | Table Ref |
|-------------|---------|----|----|----|----|----|----------|------------------------------|--------------------------|-----------|
| | FS/M | A4 | A3 | A2 | A1 | A0 | | | | |
| MODE | 0 | 1 | 0 | 1 | 0 | 1 | #21(15h) | Write during Normal and Read | Table 50 | |
| Vreg_mode | 0 | 1 | 0 | 1 | 1 | 0 | #22(16h) | Write during Normal and Read | Table 52 | |
| IO_OUT/AMUX | 0 | 1 | 0 | 1 | 1 | 1 | #23(17h) | Write during Normal and Read | Table 54 | |
| CAN Mode | 0 | 1 | 1 | 0 | 0 | 0 | #24(18h) | Write during Normal and Read | Table 56 | |
| CAN Mode 2 | 0 | 1 | 1 | 0 | 0 | 1 | #25(19h) | Write during Normal and Read | Table 58 | |

Table 13 is a list of device registers and addresses coded in bits 13 to 9 in MOSI for Main logic

Table 13. Register Mapping of Fail-safe Logic

| Register | Address | | | | | | | Hex | Write description | Table Ref |
|-------------------|---------|----|----|----|----|----|----------|--|--------------------------|-----------|
| | FS/M | A4 | A3 | A2 | A1 | A0 | | | | |
| INIT Supervisor#1 | 1 | 0 | 0 | 0 | 0 | 1 | #33(21h) | Write during INIT phase then Read only | Table 60 | |
| INIT Supervisor#2 | 1 | 0 | 0 | 0 | 1 | 0 | #34(22h) | Write during INIT phase then Read only | Table 62 | |
| INIT Supervisor#3 | 1 | 0 | 0 | 0 | 1 | 1 | #35(23h) | Write during INIT phase then Read only | Table 64 | |
| INIT FSSM#1 | 1 | 0 | 0 | 1 | 0 | 0 | #36(24h) | Write during INIT phase then Read only | Table 66 | |
| INIT FSSM#2 | 1 | 0 | 0 | 1 | 0 | 1 | #37(25h) | Write during INIT phase then Read only | Table 68 | |
| WD_Window | 1 | 0 | 0 | 1 | 1 | 0 | #38(26h) | Write (No restriction) and Read | Table 70 | |
| WD_LFSR | 1 | 0 | 0 | 1 | 1 | 1 | #39(27h) | Write (No restriction) and Read | Table 72 | |
| WD_answer | 1 | 0 | 1 | 0 | 0 | 0 | #40(28h) | Write (No restriction) and Read | Table 74 | |
| FS_OUT | 1 | 0 | 1 | 0 | 0 | 1 | #41(29h) | Write (No restriction) | Table 76 | |
| RSTb request | 1 | 0 | 1 | 0 | 1 | 0 | #42(2Ah) | Write (No restriction) | Table 78 | |
| INIT WD | 1 | 0 | 1 | 0 | 1 | 1 | #43(2Bh) | Write during INIT phase then Read only | Table 80 | |
| Diag FS1 | 1 | 0 | 1 | 1 | 0 | 0 | #44(2Ch) | Read only | Table 82 | |
| WD_Counter | 1 | 0 | 1 | 1 | 0 | 1 | #45(2Dh) | Read only | Table 84 | |
| Diag_FS2 | 1 | 0 | 1 | 1 | 1 | 0 | #46(2Eh) | Read only | Table 86 | |

7.2.2 Secured SPI Command

Some SPI commands must be secured to avoid unwanted change of the critical bits.

In the fail-safe machine and in the main state machine, the secured bits are calculated from the data bits sent as follows:

Table 14. Secured SPI

| Bit7 | Bit6 | Bit5 | Bit4 | Bit3 | Bit2 | Bit1 | Bit0 |
|--------|--------|--------|--------|----------|---------|----------|----------|
| Data 3 | Data 2 | Data 1 | Data 0 | Secure 3 | Secure2 | Secure 1 | Secure 0 |

- Secure 3 = NOT(Bit5)
- Secure 2 = NOT(Bit4)
- Secure 1 = Bit7
- Secure 0 = Bit6

7.3 Detail of Register Mapping

Default value of the reserved bit must be "0".

7.3.1 Init VREG 1

Table 15. INIT VREG1 Register Configuration

| Write | | | | | | | | | | | | | | | | |
|-------|-------|-------|-------|--------------|-------|--------|-------------|---------------|------|--------------|----------|--------------|------|------|--------------|------|
| | bit15 | bit14 | bit13 | bit12 | bit11 | bit10 | bit9 | bit8 | bit7 | bit6 | bit5 | bit4 | bit3 | bit2 | bit1 | bit0 |
| MOSI | 1 | 0 | 0 | 0 | 0 | 0 | 1 | P | 0 | Reserv ed | Ipff_DIS | Vpre_D IS | 0 | 0 | Reserv ed | 0 |
| MISO | SPI_G | WU | CAN_G | Reserve d | IO_G | Vpre_G | Vcore_ G | Vothers_ G | 0 | Reserv ed | Ipff_DIS | Vpre_D IS | 0 | 0 | Reserv ed | 0 |
| Read | | | | | | | | | | | | | | | | |
| | bit15 | bit14 | bit13 | bit12 | bit11 | bit10 | bit9 | bit8 | bit7 | bit6 | bit5 | bit4 | bit3 | bit2 | bit1 | bit0 |
| MOSI | 0 | 0 | 0 | 0 | 0 | 0 | 1 | 0 | 0 | 0 | 0 | 0 | 0 | 0 | 0 | 0 |
| MISO | SPI_G | WU | CAN_G | Reserve d | IO_G | Vpre_G | Vcore_ G | Vothers_ G | 0 | 1 | Ipff_DIS | Vpre_D IS | 0 | 0 | 1 | 0 |

Table 16. Description and Configuration of the Bits (Default value in blue)

| | | |
|----------|-----------------|--|
| IPFF_DIS | Description | DISABLE the input Power Feed Forward (IPFF) function of Vpre |
| | 0 | ENABLED |
| | 1 | DISABLED |
| | Reset condition | Power On Reset |
| Vpre_DIS | Description | DISABLE Vpre SMPS (in all mode). |
| | 0 | ENABLED |
| | 1 | DISABLED |
| | Reset condition | Power On Reset |

7.3.2 Init Vreg 2

Table 17. INIT VREG2 Register Configuration

| Write | | | | | | | | | | | | | | | | |
|-------|-------|-------|-------|----------|-------|--------|-------------|---------------|------|------------------|--------------|------|--------------|------------------|-----------------|--------------|
| | bit15 | bit14 | bit13 | bit12 | bit11 | bit10 | bit9 | bit8 | bit7 | bit6 | bit5 | bit4 | bit3 | bit2 | bit1 | bit0 |
| MOSI | 1 | 0 | 0 | 0 | 0 | 1 | 0 | P | 0 | Tcca_li m_off | lcca_li m | 0 | reserve d | Taux_li m_off | Vaux_tr k_EN | reserve d |
| MISO | SPI_G | WU | CAN_G | Reserved | IO_G | Vpre_G | Vcore_ G | Vothers_ G | 0 | Tcca_li m_off | lcca_li m | 0 | reserve d | Taux_li m_off | Vaux_tr k_EN | reserve d |

Table 17. INIT VREG2 Register Configuration

| Read | | | | | | | | | | | | | | | | |
|------|-------|-------|-------|----------|-------|--------|---------|-----------|------|--------------|----------|------|----------|--------------|-------------|----------|
| | bit15 | bit14 | bit13 | bit12 | bit11 | bit10 | bit9 | bit8 | bit7 | bit6 | bit5 | bit4 | bit3 | bit2 | bit1 | bit0 |
| MOSI | 0 | 0 | 0 | 0 | 0 | 1 | 0 | 0 | 0 | 0 | 0 | 0 | 0 | 0 | 0 | 0 |
| MISO | SPI_G | WU | CAN_G | Reserved | IO_G | Vpre_G | Vcore_G | Vothers_G | 0 | Tcca_lim_off | lcca_lim | 0 | reserved | Taux_lim_off | Vaux_trk_EN | reserved |

Table 18. INIT VREG2. Description and Configuration of the Bits (Default value in blue)

| | | |
|--------------|-----------------|--|
| Tcca_lim_off | Description | Configure the current limitation duration before regulator is switched off. Only used for external PNP |
| | 0 | 10 ms |
| | 1 | 50 ms |
| | Reset condition | Power On Reset |
| lcca_lim | Description | Configure the current limitation threshold. Only available for external PNP |
| | 0 | lcca_lim_in |
| | 1 | lcca_lim_out |
| | Reset condition | Power On Reset |
| Taux_lim_off | Description | Configure the current limitation duration before regulator is switched off. Only used for external PNP |
| | 0 | 10 ms |
| | 1 | 50 ms |
| | Reset condition | Power On Reset |
| Vaux_trk_EN | Description | Configure Vaux regulator as a tracker |
| | 0 | No tracking. HW configuration is used |
| | 1 | Tracking enabled |
| | Reset condition | Power On Reset |

7.3.3 Init CAN

Table 19. INIT CAN Register Description

| Write | | | | | | | | | | | | | | | | |
|-------|-------|-------|-------|----------|-------|--------|---------|-----------|------|-------------|----------|---------------------|-----------------------|----------|----------|----------|
| | bit15 | bit14 | bit13 | bit12 | bit11 | bit10 | bit9 | bit8 | bit7 | bit6 | bit5 | bit4 | bit3 | bit2 | bit1 | bit0 |
| MOSI | 1 | 0 | 0 | 0 | 0 | 1 | 1 | P | 0 | CAN_wu_conf | Reserved | CAN_T _{OY} | CAN_wu_T _O | reserved | reserved | reserved |
| MISO | SPI_G | WU | CAN_G | Reserved | IO_G | Vpre_G | Vcore_G | Vothers_G | 0 | CAN_wu_conf | Reserved | CAN_T _{OY} | CAN_wu_T _O | reserved | reserved | reserved |
| Read | | | | | | | | | | | | | | | | |
| | bit15 | bit14 | bit13 | bit12 | bit11 | bit10 | bit9 | bit8 | bit7 | bit6 | bit5 | bit4 | bit3 | bit2 | bit1 | bit0 |
| MOSI | 0 | 0 | 0 | 0 | 0 | 1 | 1 | 0 | 0 | 0 | 0 | 0 | 0 | 0 | 0 | 0 |

Table 19. INIT CAN Register Description

| | | | | | | | | | | | | | | | | |
|------|-------|----|-------|--------------|------|--------|-------------|---------------|---|-----------------|---|-------------|---------------|----------|----------|----------|
| MISO | SPI_G | WU | CAN_G | Reserv ed | IO_G | Vpre_G | Vcore_ G | Vothers _G | 0 | CAN_w u_conf | 0 | CAN_T OY | CAN_w u_TO | reserved | reserved | reserved |
|------|-------|----|-------|--------------|------|--------|-------------|---------------|---|-----------------|---|-------------|---------------|----------|----------|----------|

Table 20. INIT CAN. Description and Configuration of the Bits (Default value in blue)

| | | |
|-------------|-----------------|---|
| CAN_wu_conf | Description | Define the CAN wake-up mechanism |
| | 0 | 3 dominant pulses |
| | 1 | Single dominant pulse |
| | Reset condition | Power On Reset |
| CAN_TOY | Description | Configure the CAN block to be compliant with TOYOTA specification |
| | 0 | Standard CAN |
| | 1 | Toyota compliance |
| | Reset condition | Power On Reset |
| CAN_wu_to | Description | Define the CAN wake-up time-out (in case of CAN_wu_conf=0) |
| | 0 | 120 μ s |
| | 1 | 360 μ s |
| | Reset condition | Power On Reset |

7.3.4 INIT IO_WU1

Table 21. INIT IO_WU1 Register Description

| Write | | | | | | | | | | | | | | | | |
|-------|-------|-------|-------|-----------|-------|--------|---------|-----------|--------|--------|--------|--------|--------|--------|--------------|--------------|
| | bit15 | bit14 | bit13 | bit12 | bit11 | bit10 | bit9 | bit8 | bit7 | bit6 | bit5 | bit4 | bit3 | bit2 | bit1 | bit0 |
| MOSI | 1 | 0 | 0 | 0 | 1 | 0 | 0 | P | WU_0_1 | WU_0_0 | WU_1_1 | WU_1_0 | WU_2_1 | WU_2_0 | INT_inh_IO_1 | INT_inh_IO_0 |
| MISO | SPI_G | WU | CAN_G | Reserv ed | IO_G | Vpre_G | Vcore_G | Vothers_G | WU_0_1 | WU_0_0 | WU_1_1 | WU_1_0 | WU-2-1 | WU_2_0 | INT_inh_IO_1 | INT_inh_IO_0 |
| Read | | | | | | | | | | | | | | | | |
| | bit15 | bit14 | bit13 | bit12 | bit11 | bit10 | bit9 | bit8 | bit7 | bit6 | bit5 | bit4 | bit3 | bit2 | bit1 | bit0 |
| MOSI | 0 | 0 | 0 | 0 | 1 | 0 | 0 | 0 | 0 | 0 | 0 | 0 | 0 | 0 | 0 | 0 |
| MISO | SPI_G | WU | CAN_G | Reserv ed | IO_G | Vpre_G | Vcore_G | Vothers_G | WU_0_1 | WU_0_0 | WU_1_1 | WU_1_0 | WU-2-1 | WU_2_0 | INT_inh_IO_1 | INT_inh_IO_0 |

Table 22. INIT IO_WU1. Description and Configuration of the Bits (Default value in blue)

| | | |
|--------------|-----------------|--|
| WU_0_1:0 | Description | Wake-up configuration for IO_0 |
| | 0 0 | NO wake-up capability |
| | 0 1 | Wake-up on rising edge only |
| | 1 0 | Wake-up on falling edge only |
| | 1 1 | Wake-up on any edge |
| | Reset condition | Power On Reset |
| WU_1_1:0 | Description | Wake-up configuration for IO_1 |
| | 0 0 | NO wake-up capability |
| | 0 1 | Wake-up on rising edge only |
| | 1 0 | Wake-up on falling edge only |
| | 1 1 | Wake-up on any edge |
| | Reset condition | Power On Reset |
| WU_2_1:0 | Description | Wake-up configuration for IO_2 |
| | 0 0 | NO wake-up capability |
| | 0 1 | Wake-up on rising edge only |
| | 1 0 | Wake-up on falling edge only |
| | 1 1 | Wake-up on any edge |
| | Reset condition | Power On Reset |
| INT_inh_IO_1 | Description | Inhibit the INT pulse for IO_1. IO_1 masked in IO_G. Avoid INT when used in FS |
| | 0 | INT NOT masked |
| | 1 | INT masked |
| | Reset condition | Power On Reset |

Table 22. INIT IO_WU1. Description and Configuration of the Bits (Default value in blue) (continued)

| | | |
|--------------|-----------------|--|
| INT_inh_IO_0 | Description | Inhibit the INT pulse for IO_0. IO_0 masked in IO_G. Avoid INT when used in FS |
| | 0 | INT NOT masked |
| | 1 | INT masked |
| | Reset condition | Power On Reset |

7.3.5 INIT IO_WU2

Table 23. INIT IO_WU2 Register Description

| Write | | | | | | | | | | | | | | | | |
|-------|-------|-------|-------|-------|-------|-------|------|------|--------|--------|--------|--------|--------|--------|---------------|---------------|
| | bit15 | bit14 | bit13 | bit12 | bit11 | bit10 | bit9 | bit8 | bit7 | bit6 | bit5 | bit4 | bit3 | bit2 | bit1 | bit0 |
| MOSI | 1 | 0 | 0 | 0 | 1 | 0 | 1 | P | WU_3_1 | WU_3_0 | WU_4_1 | WU_4_0 | WU_5_1 | WU_5_0 | INT_inh_IO_23 | INT_inh_IO_45 |

| | | | | | | | | | | | | | | | | |
|------|-------|----|-------|----------|------|--------|---------|-----------|--------|--------|--------|--------|--------|--------|---------------|---------------|
| MISO | SPI_G | WU | CAN_G | Reserved | IO_G | Vpre_G | Vcore_G | Vothers_G | WU_3_1 | WU_3_0 | WU_4_1 | WU_4_0 | WU_5_1 | WU_5_0 | INT_inh_IO_23 | INT_inh_IO_45 |
|------|-------|----|-------|----------|------|--------|---------|-----------|--------|--------|--------|--------|--------|--------|---------------|---------------|

| Read | | | | | | | | | | | | | | | | |
|------|-------|-------|-------|-------|-------|-------|------|------|------|------|------|------|------|------|------|------|
| | bit15 | bit14 | bit13 | bit12 | bit11 | bit10 | bit9 | bit8 | bit7 | bit6 | bit5 | bit4 | bit3 | bit2 | bit1 | bit0 |
| MOSI | 0 | 0 | 0 | 0 | 1 | 0 | 1 | 0 | 0 | 0 | 0 | 0 | 0 | 0 | 0 | 0 |

| | | | | | | | | | | | | | | | | |
|------|-------|----|-------|----------|------|--------|---------|-----------|--------|--------|--------|--------|--------|--------|---------------|---------------|
| MISO | SPI_G | WU | CAN_G | Reserved | IO_G | Vpre_G | Vcore_G | Vothers_G | WU_3_1 | WU_3_0 | WU_4_1 | WU_4_0 | WU_5_1 | WU_5_0 | INT_inh_IO_23 | INT_inh_IO_45 |
|------|-------|----|-------|----------|------|--------|---------|-----------|--------|--------|--------|--------|--------|--------|---------------|---------------|

Table 24. INIT IO_WU2. Description and Configuration of the Bits (Default value in blue)

| | | |
|----------|-----------------|--------------------------------|
| WU_3_1:0 | Description | Wake-up configuration for IO_3 |
| | 0 0 | NO wake-up capability |
| | 0 1 | Wake-up on rising edge only |
| | 1 0 | Wake-up on falling edge only |
| | 1 1 | Wake-up on any edge |
| | Reset condition | Power On Reset |
| WU_4_1:0 | Description | Wake-up configuration for IO_4 |
| | 0 0 | NO wake-up capability |
| | 0 1 | Wake-up on rising edge only |
| | 1 0 | Wake-up on falling edge only |
| | 1 1 | Wake-up on any edge |
| | Reset condition | Power On Reset |

Table 24. INIT IO_WU2. Description and Configuration of the Bits (Default value in blue) (continued)

| | | |
|---------------|-----------------|--|
| WU_5_1:0 | Description | Wake-up configuration for IO_5 |
| | 0 0 | NO wake-up capability |
| | 0 1 | Wake-up on rising edge only |
| | 1 0 | Wake-up on falling edge only |
| | 1 1 | Wake-up on any edge |
| | Reset condition | Power On Reset |
| INT_inh_IO_45 | Description | Inhibit the INT pulse for IO_4 & IO_5. IO_4 & IO_5 masked in IO_G. Avoid INT when used in FS |
| | 0 | INT NOT masked |
| | 1 | INT masked |
| | Reset condition | Power On Reset |
| INT_inh_IO_23 | Description | Inhibit the INT pulse for IO_2 & IO_3. IO_2 & IO_3 masked in IO_G. Avoid INT when used in FS |
| | 0 | INT NOT masked |
| | 1 | INT masked |
| | Reset condition | Power On Reset |

7.3.6 INIT INT

Table 25. INIT INT Register Description

| Write | | | | | | | | | | | | | | | | |
|-------|-------|-------|-------|-------|-------|-------|------|------|--------------|----------|-------------|--------------|--------------|---------------|-----------------|----------|
| | bit15 | bit14 | bit13 | bit12 | bit11 | bit10 | bit9 | bit8 | bit7 | bit6 | bit5 | bit4 | bit3 | bit2 | bit1 | bit0 |
| MOSI | 1 | 0 | 0 | 0 | 1 | 1 | 0 | P | INT_duration | reserved | INT_inh_all | INT_inh_Vsns | INT_inh_Vpre | INT_inh_Vcore | INT_inh_Vothers | reserved |

| | | | | | | | | | | | | | | | | |
|------|-------|----|-------|----------|------|--------|---------|-----------|--------------|---|-------------|--------------|--------------|---------------|-----------------|---|
| MISO | SPI_G | WU | CAN_G | Reserved | IO_G | Vpre_G | Vcore_G | Vothers_G | INT_duration | 0 | INT_inh_all | INT_inh_Vsns | INT_inh_Vpre | INT_inh_Vcore | INT_inh_Vothers | 0 |
|------|-------|----|-------|----------|------|--------|---------|-----------|--------------|---|-------------|--------------|--------------|---------------|-----------------|---|

| Read | | | | | | | | | | | | | | | | |
|------|-------|-------|-------|-------|-------|-------|------|------|------|------|------|------|------|------|------|------|
| | bit15 | bit14 | bit13 | bit12 | bit11 | bit10 | bit9 | bit8 | bit7 | bit6 | bit5 | bit4 | bit3 | bit2 | bit1 | bit0 |
| MOSI | 0 | 0 | 0 | 0 | 1 | 1 | 0 | 0 | 0 | 0 | 0 | 0 | 0 | 0 | 0 | 0 |

| | | | | | | | | | | | | | | | | |
|------|-------|----|-------|----------|------|--------|---------|-----------|--------------|---|-------------|--------------|--------------|---------------|-----------------|---|
| MISO | SPI_G | WU | CAN_G | Reserved | IO_G | Vpre_G | Vcore_G | Vothers_G | INT_duration | 0 | INT_inh_all | INT_inh_Vsns | INT_inh_Vpre | INT_inh_Vcore | INT_inh_Vothers | 0 |
|------|-------|----|-------|----------|------|--------|---------|-----------|--------------|---|-------------|--------------|--------------|---------------|-----------------|---|

Table 26. INIT INT. Description and Configuration of the Bits (Default value in blue)

| | | |
|--------------|-----------------|--|
| INT_duration | Description | Define the duration of the INTerrupt pulse |
| | 0 | 100 μ s |
| | 1 | 25 μ s |
| | Reset condition | Power On Reset |

Table 26. INIT INT. Description and Configuration of the Bits (Default value in blue) (continued)

| | | |
|-----------------|-----------------|---|
| INT_inh_all | Description | Inhibit ALL the INT |
| | 0 | All INT sources |
| | 1 | inhibit ALL INT |
| | Reset condition | Power On Reset |
| INT_inh_Vsns | Description | Inhibit the INT for V _{SNS_UV} |
| | 0 | All INT sources |
| | 1 | inhibit V _{SNS_UV} |
| | Reset condition | Power On Reset |
| INT_inh_Vpre | Description | Inhibit the INT for Vpre status event (cf. register status Vreg1) |
| | 0 | All INT sources |
| | 1 | Vpre status changed INHIBITED |
| | Reset condition | Power On Reset |
| INT_inh_Vcore | Description | Inhibit the INT for Vcore status event (cf. register status Vreg2) |
| | 0 | All INT sources |
| | 1 | Vcore status changed INHIBITED |
| | Reset condition | Power On Reset |
| INT_inh_Vothers | Description | Inhibit the INT for V _{CCA} / V _{AUX} and V _{CAN} status event (cf. register status Vreg2) |
| | 0 | All INT sources |
| | 1 | V _{CCA} / V _{AUX} / V _{CAN} status changed INHIBITED |
| | Reset condition | Power On Reset |

7.3.7 HW Config

Table 27. HW Config Register Description

| Read | | | | | | | | | | | | | | | | |
|------|-------|-------|-------|----------|-------|--------|---------|-----------|-----------|---------------|-----------------|---------|---------|------|------|------|
| | bit15 | bit14 | bit13 | bit12 | bit11 | bit10 | bit9 | bit8 | bit7 | bit6 | bit5 | bit4 | bit3 | bit2 | bit1 | bit0 |
| MOSI | 0 | 0 | 0 | 1 | 0 | 0 | 0 | 0 | 0 | 0 | 0 | 0 | 0 | 0 | 0 | 0 |
| MISO | SPI_G | WU | CAN_G | Reserved | IO_G | Vpre_G | Vcore_G | Vothers_G | LS_detect | Vaux not used | Vcca_PNP_detect | Vcca_HW | Vaux_HW | x | 0 | DBG |

Table 28. HW Config. Description and Configuration of the Bits (Default value in blue)

| | | |
|---------------|-----------------|---|
| LS_detect | Description | Report the hardware configuration of Vpre (Buck only or Buck-Boost) |
| | 0 | Buck-Boost |
| | 1 | Buck only |
| | Reset condition | Power On Reset / Refresh after LPOFF |
| Vaux not used | Description | Report if Vaux is used |
| | 0 | Vaux is used (external PNP is assumed to be connected, Vaux can be switched OFF/ON through SPI) |
| | 1 | Vaux is not used |
| | Reset condition | Power On Reset / Refresh after LPOFF |

Table 28. HW Config. Description and Configuration of the Bits (Default value in blue) (continued)

| | | |
|-----------------|-----------------|--|
| Vcca_PNP_detect | Description | Report the connection of an external PNP on Vcca |
| | 0 | External PNP connected |
| | 1 | Internal MOSFET |
| | Reset condition | Power On Reset / Refresh after LPOFF |
| Vcca_HW | Description | Report the hardware configuration for Vcca |
| | 0 | 3.3 V |
| | 1 | 5 V |
| | Reset condition | Power On Reset / Refresh after LPOFF |
| Vaux_HW 1:0 | Description | Report the hardware configuration for Vaux |
| | 0 | 5 V |
| | 1 | 3.3 V |
| | Reset condition | Power On Reset / Refresh after LPOFF |
| DBG | Description | Report the configuration of the DEBUG mode |
| | 0 | Normal operation |
| | 1 | DEBUG mode selected |
| | Reset condition | Power On Reset / Refresh after LPOFF |

WU SOURCE

Table 29. WU SOURCE Register Description

| Read | | | | | | | | | | | | | | | | |
|------|-------|-------|-------|----------|-------|--------|---------|-----------|---------|---------|---------|---------|---------|---------|---------|--------|
| | bit15 | bit14 | bit13 | bit12 | bit11 | bit10 | bit9 | bit8 | bit7 | bit6 | bit5 | bit4 | bit3 | bit2 | bit1 | bit0 |
| MOSI | 0 | 0 | 0 | 1 | 0 | 0 | 1 | 0 | 0 | 0 | 0 | 0 | 0 | 0 | 0 | 0 |
| MISO | SPI_G | WU | CAN_G | Reserved | IO_G | Vpre_G | Vcore_G | Vothers_G | IO_5_WU | IO_4_WU | IO_3_WU | IO_2_WU | IO_1_WU | IO_0_WU | Vreg_WU | Phy_WU |

Table 30. WU source. Description and Configuration of the Bits (Default value in blue)

| | | |
|---------|-----------------|----------------------------------|
| IO_5_WU | Description | Report a wake-up event from IO_5 |
| | 0 | No Wake-up |
| | 1 | WU event detected |
| | Reset condition | Power On Reset / Read |
| IO_4_WU | Description | Report a wake-up event from IO_4 |
| | 0 | No Wake-up |
| | 1 | WU event detected |
| | Reset condition | Power On Reset / Read |
| IO_3_WU | Description | Report a wake-up event from IO_3 |
| | 0 | No Wake-up |
| | 1 | WU event detected |
| | Reset condition | Power On Reset / Read |
| IO_2_WU | Description | Report a wake-up event from IO_2 |
| | 0 | No Wake-up |
| | 1 | WU event detected |
| | Reset condition | Power On Reset / Read |
| IO_1_WU | Description | Report a wake-up event from IO_1 |
| | 0 | No Wake-up |
| | 1 | WU event detected |
| | Reset condition | Power On Reset / Read |
| IO_0_WU | Description | Report a wake-up event from IO_0 |
| | 0 | No Wake-up |
| | 1 | WU event detected |
| | Reset condition | Power On Reset / Read |
| Phy_WU | Description | Report a wake-up event from CAN |
| | 0 | No Wake-up |
| | 1 | WU event detected |
| | Reset condition | Power On Reset/ Read CAN_wu |

IO INPUT

Table 31. IO INPUT Register Description

| Read | | | | | | | | | | | | | | | | |
|------|-------|-------|-------|----------|-------|--------|---------|-----------|------|------|------|------|------|------|------|------|
| | bit15 | bit14 | bit13 | bit12 | bit11 | bit10 | bit9 | bit8 | bit7 | bit6 | bit5 | bit4 | bit3 | bit2 | bit1 | bit0 |
| MOSI | 0 | 0 | 0 | 1 | 0 | 1 | 1 | 0 | 0 | 0 | 0 | 0 | 0 | 0 | 0 | 0 |
| MISO | SPI_G | WU | CAN_G | Reserved | IO_G | Vpre_G | Vcore_G | Vothers_G | IO_5 | IO_4 | 0 | IO_3 | IO_2 | 0 | IO_1 | IO_0 |

Table 32. IO input. Description and Configuration of the Bits

| | | |
|------|-----------------|--|
| IO_5 | Description | Report IO_5 digital state in Normal mode. No update in LPOFF mode since wake-up features available |
| | 0 | Low |
| | 1 | High |
| | Reset condition | Power On Reset |
| IO_4 | Description | Report IO_4 digital state in Normal mode. No update in LPOFF mode since wake-up features available |
| | 0 | Low |
| | 1 | High |
| | Reset condition | Power On Reset |
| IO_3 | Description | Report IO_3 digital state in Normal mode. No update in LPOFF mode since wake-up features available |
| | 0 | Low |
| | 1 | High |
| | Reset condition | Power On Reset |
| IO_2 | Description | Report IO_2 digital state in Normal mode. No update in LPOFF mode since wake-up features available |
| | 0 | Low |
| | 1 | High |
| | Reset condition | Power On Reset |
| IO_1 | Description | Report IO_1 digital state in Normal mode. No update in LPOFF mode since wake-up features available |
| | 0 | Low |
| | 1 | High |
| | Reset condition | Power On Reset |
| IO_0 | Description | Report IO_0 digital state in Normal mode. No update in LPOFF mode since wake-up features available |
| | 0 | Low |
| | 1 | High |
| | Reset condition | Power On Reset |

STATUS VREG1

Table 33. STATUS VREG1 Register Description

| Read | | | | | | | | | | | | | | | | |
|------|-------|-------|-------|-----------|-------|--------|---------|-----------|------|----------|-----------|------|------------|------|------|------|
| | bit15 | bit14 | bit13 | bit12 | bit11 | bit10 | bit9 | bit8 | bit7 | bit6 | bit5 | bit4 | bit3 | bit2 | bit1 | bit0 |
| MOSI | 0 | 0 | 0 | 1 | 1 | 0 | 0 | 0 | 0 | 0 | 0 | 0 | 0 | 0 | 0 | 0 |
| MISO | SPI_G | WU | CAN_G | Reserve_d | IO_G | Vpre_G | Vcore_G | Vothers_G | IpFF | llim_pre | Twarm_pre | BoB | Vpre_state | 0 | 0 | 0 |

Table 34. Status Vreg1. Description and Configuration of the Bits (Default value in blue)

| | | |
|------------|-----------------|--|
| IpFF | Description | Input Power Feed Forward |
| | 0 | Normal Operation |
| | 1 | Ipff mode activated |
| | Reset condition | Power On Reset / Read |
| llim_pre | Description | Report a current limitation condition on Vpre |
| | 0 | No current limitation ($I_{pre_pk} < I_{pre_lim}$) |
| | 1 | Current limitation ($I_{pre_pk} > I_{pre_lim}$) |
| | Reset condition | Power On Reset / Read |
| Twarm_pre | Description | Report a thermal warning from Vpre |
| | 0 | No thermal warning ($T_j < T_{warm_pre}$) |
| | 1 | Thermal warning ($T_j > T_{warm_pre}$) |
| | Reset condition | Power On Reset / Read |
| BoB | Description | Report a running mode of Vpre |
| | 0 | Buck |
| | 1 | Boost |
| | Reset condition | Power On Reset |
| Vpre_state | Description | Report the activation state of Vpre SMPS |
| | 0 | SMPS OFF |
| | 1 | SMPS ON |
| | Reset condition | Power On Reset |

STATUS VREG2

Table 35. STATUS VREG2 Register Description

| Read | | | | | | | | | | | | | | | | |
|------|-------|-------|-------|----------|-------|--------|---------|-----------|-----------|------------|-------------|-----------|----------|----------|----------|------|
| | bit15 | bit14 | bit13 | bit12 | bit11 | bit10 | bit9 | bit8 | bit7 | bit6 | bit5 | bit4 | bit3 | bit2 | bit1 | bit0 |
| MOSI | 0 | 0 | 0 | 1 | 1 | 0 | 1 | 0 | 0 | 0 | 0 | 0 | 0 | 0 | 0 | 0 |
| MISO | SPI_G | WU | CAN_G | Reserved | IO_G | Vpre_G | Vcore_G | Vothers_G | llim_core | Twarm_core | Vcore_state | Twarm_cca | llim_cca | llim_aux | llim_can | 0 |

Table 36. Status Vreg2. Description and Configuration of the Bits (Default value in blue)

| | | |
|-------------|-----------------|---|
| llim_core | Description | Report a current limitation condition on Vcore |
| | 0 | No current limitation ($I_{core_pk} < I_{core_lim}$) |
| | 1 | Current limitation ($I_{core_pk} > I_{core_lim}$) |
| | Reset condition | Power On Reset / Read |
| Twarm_core | Description | Report a thermal warning from Vcore |
| | 0 | No thermal warning ($T_j < T_{warm_core}$) |
| | 1 | Thermal warning ($T_j > T_{warm_core}$) |
| | Reset condition | Power On Reset / Read |
| Vcore_state | Description | Report the activation state of Vcore SMPS |
| | 0 | SMPS OFF |
| | 1 | SMPS ON |
| | Reset condition | Power On Reset |
| Twarm_cca | Description | Report a thermal warning from Vcca. Available only for internal pass MOSFET |
| | 0 | No thermal warning ($T_j < T_{warm_cca}$) |
| | 1 | Thermal warning ($T_j > T_{warm_cca}$) |
| | Reset condition | Power On Reset |
| llim_cca | Description | Report a current limitation condition on Vcca |
| | 0 | No current limitation ($I_{cca} < I_{cca_lim}$) |
| | 1 | Current limitation ($I_{cca} > I_{cca_lim}$) |
| | Reset condition | Power On Reset / Read |
| llim_aux | Description | Report a current limitation condition on Vaux |
| | 0 | No current limitation ($I_{aux} < I_{aux_lim}$) |
| | 1 | Current limitation ($I_{aux} > I_{aux_lim}$) |
| | Reset condition | Power On Reset / Read |
| llim_can | Description | Report a current limitation condition on Vcan |
| | 0 | NO current limitation ($I_{can} < I_{can_lim}$) |
| | 1 | Current limitation ($I_{can} > I_{can_lim}$) |
| | Reset condition | Power On Reset / Read |

DIAG VREG1

Table 37. DIAG VREG1 Register Description

| Read | | | | | | | | | | | | | | | | |
|------|-------|-------|-------|----------|-------|--------|---------|-----------|---------|-----------|---------|---------|---------|----------|----------|----------|
| | bit15 | bit14 | bit13 | bit12 | bit11 | bit10 | bit9 | bit8 | bit7 | bit6 | bit5 | bit4 | bit3 | bit2 | bit1 | bit0 |
| MOSI | 0 | 0 | 0 | 1 | 1 | 1 | 0 | 0 | 0 | 0 | 0 | 0 | 0 | 0 | 0 | 0 |
| MISO | SPI_G | WU | CAN_G | Reserved | IO_G | Vpre_G | Vcore_G | Vothers_G | Vsns_uv | Vsup_uv_7 | Tsd_pre | Vpre_OV | Vpre_uv | Tsd_core | Vcore_OV | Vcore_uv |

Table 38. Diag Vreg1. Description and Configuration of the Bits (Default value in blue)

| | | |
|-----------|-----------------|---|
| Vsns_uv | Description | Detection of Vbattery below Vsns_uv |
| | 0 | Vbat > Vsns_uv |
| | 1 | Vbat < Vsns_uv |
| | Reset condition | Power On Reset / Read |
| Vsup_uv_7 | Description | Detection of Vsup below Vsup_uv_7 |
| | 0 | Vsup > Vsup_uv_7 |
| | 1 | Vsup < Vsup_uv_7 |
| | Reset condition | Power On Reset / Read |
| Tsd_pre | Description | Thermal shutdown of Vpre |
| | 0 | No TSD (Tj < Tsd_pre) |
| | 1 | TSD occurred (Tj > Tsd_pre) |
| | Reset condition | Power On Reset / Read |
| Vpre_OV | Description | Vpre overvoltage detection |
| | 0 | No overvoltage (Vpre < Vpre_ov) |
| | 1 | Overvoltage detected (Vpre > Vpre_ov) |
| | Reset condition | Power On Reset |
| Vpre_UV | Description | Vpre undervoltage detection |
| | 0 | No undervoltage (Vpre > Vpre_uv) |
| | 1 | Under voltage detected (Vpre < Vpre_uv) |
| | Reset condition | Power On Reset / Read |
| Tsd_core | Description | Thermal shutdown of Vcore |
| | 0 | No TSD (Tj < Tsd_core) |
| | 1 | TSD occurred (Tj > Tsd_core) |
| | Reset condition | Power On Reset / Read |
| Vcore_OV | Description | Vcore overvoltage detection |
| | 0 | No overvoltage (Vcore < Vcore_ov) |
| | 1 | Overvoltage detected (Vcore > Vcore_ov) |
| | Reset condition | Power On Reset / Read |
| Vcore_UV | Description | Vcore undervoltage detection |
| | 0 | No undervoltage (Vcore > Vcore_uv) |
| | 1 | Undervoltage (Vcore < Vcore_uv) |
| | Reset condition | Power On Reset / Read |

DIAG VREG2

Table 39. DIAG VREG2 Register Description

| Read | | | | | | | | | | | | | | | | |
|------|-------|-------|-------|----------|-------|--------|---------|-----------|---------|---------|---------|------|---------|--------------|---------|---------|
| | bit15 | bit14 | bit13 | bit12 | bit11 | bit10 | bit9 | bit8 | bit7 | bit6 | bit5 | bit4 | bit3 | bit2 | bit1 | bit0 |
| MOSI | 0 | 0 | 0 | 1 | 1 | 1 | 1 | 0 | 0 | 0 | 0 | 0 | 0 | 0 | 0 | 0 |
| MISO | SPI_G | WU | CAN_G | Reserved | IO_G | Vpre_G | Vcore_G | Vothers_G | Tsd_Can | Vcan_OV | Vcan_uv | 0 | Tsd_aux | llim_aux_off | Vaux_OV | Vaux_uv |

Table 40. Diag Vreg2. Description and Configuration of the Bits (Default value in blue)

| | | |
|--------------|-----------------|---|
| Tsd_can | Description | Thermal shutdown of Vcan |
| | 0 | NO TSD ($T_j < Tsd_can$) |
| | 1 | TSD occurred ($T_j > Tsd_can$) |
| | Reset condition | Power On Reset / Read |
| Vcan_OV | Description | Vcan Overvoltage detection |
| | 0 | No Overvoltage ($Vcan < Vcan_OV$) |
| | 1 | Overvoltage detected ($Vcan > Vcan_OV$) |
| | Reset condition | Power On Reset / Read |
| Vcan_uv | Description | Vcan undervoltage detection |
| | 0 | No undervoltage ($Vcan > Vcan_uv$) |
| | 1 | Undervoltage detected ($Vcan < Vcan_uv$) |
| | Reset condition | Power On Reset / Read |
| Tsd_aux | Description | Thermal shutdown of Vaux |
| | 0 | No TSD ($T_j < Tsd_aux$) |
| | 1 | TSD occurred ($T_j > Tsd_aux$) |
| | Reset condition | Power On Reset |
| llim_aux_off | Description | Maximum current limitation duration |
| | 0 | $T_limitation < Taux_lim_off$ |
| | 1 | $T_limitation > Taux_lim_off$ |
| | Reset condition | Power On Reset / Read |
| Vaux_OV | Description | Vaux overvoltage detection |
| | 0 | No overvoltage ($Vaux < Vaux_OV$) |
| | 1 | Overvoltage detected ($Vaux > Vaux_OV$) |
| | Reset condition | Power On Reset / Read |
| Vaux_UV | Description | Vaux undervoltage detection |
| | 0 | No undervoltage ($Vaux > Vaux_uv$) |
| | 1 | undervoltage detected ($Vaux < Vaux_uv$) |
| | Reset condition | Power On Reset / Read |

DIAG VREG 3

Table 41. DIAG VREG3 Register Description

| | | | | | | | | | | | | | | | | |
|------|-------|-------|-------|----------|-------|--------|---------|-----------|---------|------|--------------|------|---------|------|---------|------|
| Read | | | | | | | | | | | | | | | | |
| | bit15 | bit14 | bit13 | bit12 | bit11 | bit10 | bit9 | bit8 | bit7 | bit6 | bit5 | bit4 | bit3 | bit2 | bit1 | bit0 |
| MOSI | 0 | 0 | 1 | 0 | 0 | 0 | 0 | 0 | 0 | 0 | 0 | 0 | 0 | 0 | 0 | 0 |
| MISO | SPI_G | WU | CAN_G | Reserved | IO_G | Vpre_G | Vcore_G | Vothers_G | Tsd_cca | 0 | llim-cca_off | 0 | Vcca_OV | 0 | Vcca_UV | 0 |

Table 42. Diag Vreg3. Description and Configuration of the Bits (Default value in blue)

| | | |
|--------------|-----------------|---|
| Tsd_cca | Description | Thermal shutdown of Vcca |
| | 0 | NO TSD ($T_j < Tsd_cca$) |
| | 1 | TSD occurred ($T_j > Tsd_cca$) |
| | Reset condition | Power On Reset / Read |
| llim_cca_off | Description | Maximum current limitation duration. Available only when an external PNP is connected |
| | 0 | $T_limitation < Tcca_lim_off$ |
| | 1 | $T_limitation > Tcca_lim_off$ |
| | Reset condition | Power On Reset / Read |
| Vcca_OV | Description | Vcca overvoltage detection |
| | 0 | No overvoltage ($Vcca < Vcca_OV$) |
| | 1 | Overvoltage detected ($Vcca > Vcca_OV$) |
| | Reset condition | Power On Reset / Read |
| Vcca_UV | Description | Vcca undervoltage detection |
| | 0 | No undervoltage ($Vcca > Vcca_uv$) |
| | 1 | Undervoltage detected ($Vcca < Vcca_uv$) |
| | Reset condition | Power On Reset |

Archive Information

Archive Information

DIAG CAN1

Table 43. DIAG CAN1 Register Description

| Read | | | | | | | | | | | | | | | | |
|------|-------|-------|-------|----------|-------|--------|---------|-----------|-----------|----------|-----------|----------|--------------|------|---------------|--------------|
| | bit15 | bit14 | bit13 | bit12 | bit11 | bit10 | bit9 | bit8 | bit7 | bit6 | bit5 | bit4 | bit3 | bit2 | bit1 | bit0 |
| MOSI | 0 | 0 | 1 | 0 | 0 | 0 | 1 | 0 | 0 | 0 | 0 | 0 | 0 | 0 | 0 | 0 |
| MISO | SPI_G | WU | CAN_G | Reserved | IO_G | Vpre_G | Vcore_G | Vothers_G | CANH_batt | CANH_gnd | CANL_batt | CANL_gnd | CAN_dominant | 0 | RXD_recessive | TXD_dominant |

Table 44. Diag CAN1. Description and Configuration of the Bits (Default value in blue)

| | | |
|---------------|-----------------|--|
| CANH_batt | Description | CANH short circuit to battery detection |
| | 0 | NO failure |
| | 1 | Failure detected |
| | Reset condition | Power On Reset / Read |
| CANH_gnd | Description | CANH short circuit to gnd detection |
| | 0 | NO failure |
| | 1 | Failure detected |
| | Reset condition | Power On Reset / Read |
| CANL_batt | Description | CANL short circuit to battery detection |
| | 0 | NO failure |
| | 1 | Failure detected |
| | Reset condition | Power On Reset / Read |
| CANL_gnd | Description | CANL short circuit to gnd detection |
| | 0 | NO failure |
| | 1 | Failure detected |
| | Reset condition | Power On Reset / Read |
| CAN_dominant | Description | CAN Bus dominant clamping detection |
| | 0 | NO failure |
| | 1 | Failure detected |
| | Reset condition | Power On Reset / Read |
| RXD_recessive | Description | RXD recessive clamping detection (short circuit to 5V) |
| | 0 | NO failure |
| | 1 | Failure detected |
| | Reset condition | Power On Reset / Read |
| TXD_dominant | Description | TXD dominant clamping detection (short circuit to GND) |
| | 0 | NO failure |
| | 1 | Failure detected |
| | Reset condition | Power On Reset / Read |

DIAG CAN2

Table 45. DIAG CAN2 Register Description

| | | | | | | | | | | | | | | | | |
|------|-------|-------|-------|--------------|-------|--------|-------------|---------------|--------------|--------------|------|--------------|--------------|------|------------|------------|
| Read | | | | | | | | | | | | | | | | |
| | bit15 | bit14 | bit13 | bit12 | bit11 | bit10 | bit9 | bit8 | bit7 | bit6 | bit5 | bit4 | bit3 | bit2 | bit1 | bit0 |
| MOSI | 0 | 0 | 1 | 0 | 0 | 1 | 0 | 0 | 0 | 0 | 0 | 0 | 0 | 0 | 0 | 0 |
| MISO | SPI_G | WU | CAN_G | Reserv ed | IO_G | Vpre_G | Vcore_ G | Vothers _G | reserve d | reserve d | 0 | reserve d | reserve d | 0 | CAN_O T | CAN_O C |

Table 46. Diag CAN2. Description and Configuration of the Bits (Default value in blue)

| | | |
|--------|-----------------|-------------------------------|
| CAN_OT | Description | CAN overtemperature detection |
| | 0 | NO failure |
| | 1 | Failure detected |
| | Reset condition | Power On Reset / Read |
| CAN_OC | Description | CAN overcurrent detection |
| | 0 | NO failure |
| | 1 | Failure detected |
| | Reset condition | Power On Reset / Read |

Table 47. Distinguish between CAN Diagnostic and CAN Error

| Register | Bit | Flag Type | Effect |
|-----------|---------------|------------|--------------------------|
| DIAG CAN1 | CANH_batt | Diagnostic | No impact |
| | CANH_gnd | Diagnostic | No impact |
| | CANL_batt | Diagnostic | No impact |
| | CANL_gnd | Diagnostic | No impact |
| | CAN_dominant | Error | Turn OFF CAN transceiver |
| | RXD_recessive | Error | Turn OFF CAN transceiver |
| | TXD_dominant | Error | Turn OFF CAN transceiver |
| DIAG CAN2 | CAN_OT | Error | Turn OFF CAN transceiver |
| | CAN_OC | Diagnostic | No impact |

DIAG SPI

Table 48. DIAG SPI Register Description

| Read | | | | | | | | | | | | | | | | |
|------|-------|-------|-------|--------------|-------|--------|-------------|---------------|---------|------|---------|------|-------------|------|----------------|------|
| | bit15 | bit14 | bit13 | bit12 | bit11 | bit10 | bit9 | bit8 | bit7 | bit6 | bit5 | bit4 | bit3 | bit2 | bit1 | bit0 |
| MOSI | 0 | 0 | 1 | 0 | 0 | 1 | 1 | 0 | 0 | 0 | 0 | 0 | 0 | 0 | 0 | 0 |
| MISO | SPI_G | WU | CAN_G | Reserv ed | IO_G | Vpre_G | Vcore_ G | Vothers _G | SPI_err | 0 | SPI_clk | 0 | SPI_re q | 0 | SPI_pa rity | 0 |

Table 49. Diag SPI. Description and Configuration of the Bits (Default value in blue)

| | | |
|------------|-----------------|---|
| SPI_err | Description | Secured SPI communication check |
| | 0 | No error |
| | 1 | Error detected in the secured bits |
| | Reset condition | Power On Reset / Read |
| SPI_CLK | Description | SCLK error detection |
| | 0 | 16 clock cycles during NCS low |
| | 1 | Wrong number of clock cycles (<16 or > 16) |
| | Reset condition | Power On Reset / Read |
| SPI_req | Description | Invalid SPI access (Wrong Write or Read, Write to INIT registers in normal mode, wrong address) |
| | 0 | No error |
| | 1 | SPI violation |
| | Reset condition | Power On Reset / Read |
| SPI_parity | Description | SPI parity bit error detection |
| | 0 | Parity bit OK |
| | 1 | Parity bit error |
| | Reset condition | Power On Reset / Read |

MODE

Table 50. MODE Register Description

| Write | | | | | | | | | | | | | | | | |
|-------|-------|-------|-------|----------|-------|--------|---------|-----------|----------|----------|------------|-------------|----------|----------|----------|----------|
| | bit15 | bit14 | bit13 | bit12 | bit11 | bit10 | bit9 | bit8 | bit7 | bit6 | bit5 | bit4 | bit3 | bit2 | bit1 | bit0 |
| MOSI | 1 | 0 | 1 | 0 | 1 | 0 | 1 | P | reserved | reserved | Goto_LPOFF | INT_request | Secure_3 | Secure_2 | Secure_1 | Secure_0 |
| MISO | SPI_G | WU | CAN_G | Reserved | IO_G | Vpre_G | Vcore_G | Vothers_G | 0 | 0 | 0 | 0 | INIT | Normal | reserved | reserved |
| Read | | | | | | | | | | | | | | | | |
| | bit15 | bit14 | bit13 | bit12 | bit11 | bit10 | bit9 | bit8 | bit7 | bit6 | bit5 | bit4 | bit3 | bit2 | bit1 | bit0 |
| MOSI | 0 | 0 | 1 | 0 | 1 | 0 | 1 | 0 | 0 | 0 | 0 | 0 | 0 | 0 | 0 | 0 |
| MISO | SPI_G | WU | CAN_G | Reserved | IO_G | Vpre_G | Vcore_G | Vothers_G | 0 | 0 | 0 | 0 | INIT | Normal | reserved | reserved |

Table 51. MODE. Description and Configuration of the Bits (Default value in blue)

| | | |
|-------------|-----------------|---|
| Goto_LPOFF | Description | Configure the device in Low Power mode Vreg OFF (LPOFF) |
| | 0 | No action |
| | 1 | LPOFF mode |
| | Reset condition | Power On Reset |
| INIT | Description | Report if INIT mode of the main logic state machine is entered |
| | 0 | Not in INIT mode |
| | 1 | INIT MODE |
| | Reset condition | Power On Reset |
| Normal | Description | Report if Normal mode of the main logic state machine is entered |
| | 0 | Not in Normal mode |
| | 1 | Normal mode |
| | Reset condition | Power On Reset |
| INT_request | Description | Request for an INT pulse |
| | 0 | No Request |
| | 1 | Request for an INT pulse |
| | Reset condition | Power On Reset |
| Secure 3:0 | Description | Secured bits based on write bits |
| | | secured_3 = NOT(bit5) Secured_2= NOT(bit4) Secured_1=bit7 Secured_0=bit6 |

VREG MODE

Table 52. VREG MODE Register Description

| Write | | | | | | | | | | | | | | | | |
|-------|-------|-------|----------|-------|--------|---------|-----------|----------|----------|----------|----------|----------|----------|----------|----------|----------|
| | bit15 | bit14 | bit13 | bit12 | bit11 | bit10 | bit9 | bit8 | bit7 | bit6 | bit5 | bit4 | bit3 | bit2 | bit1 | bit0 |
| MOSI | 1 | 0 | 1 | 0 | 1 | 1 | 0 | P | Vcore_EN | Vcca_EN | Vaux_EN | Vcan_EN | Secure_3 | Secure_2 | Secure_1 | Secure_0 |
| Read | | | | | | | | | | | | | | | | |
| | bit15 | bit14 | bit13 | bit12 | bit11 | bit10 | bit9 | bit8 | bit7 | bit6 | bit5 | bit4 | bit3 | bit2 | bit1 | bit0 |
| MOSI | 0 | 0 | 1 | 0 | 1 | 1 | 0 | 0 | 0 | 0 | 0 | 0 | 0 | 0 | 0 | 0 |
| MISO | | | | | | | | | | | | | | | | |
| SPI_G | WU | CAN_G | Reserved | IO_G | Vpre_G | Vcore_G | Vothers_G | reserved | reserved | reserved | reserved | reserved | Vcore_EN | Vcca_EN | Vaux_EN | Vcan_EN |

Table 53. VREG MODE. Description and Configuration of the Bits (Default value in blue)

| | | |
|------------|-----------------|---|
| Vcore_EN | Description | Vcore control (Switch OFF not possible if Vcore is SAFETY critical) |
| | 0 | DISABLED |
| | 1 | ENABLED |
| | Reset condition | Power On Reset |
| Vcca_EN | Description | Vcca control (Switch OFF NOT possible if Vcca is SAFETY critical) |
| | 0 | DISABLED |
| | 1 | ENABLED |
| | Reset condition | Power On Reset |
| Vaux_EN | Description | Vaux control (Switch OFF NOT possible if Vaux is SAFETY critical) |
| | 0 | DISABLED |
| | 1 | ENABLED |
| | Reset condition | Power On Reset |
| VCAN_EN | Description | Vcan control |
| | 0 | DISABLED |
| | 1 | ENABLED |
| | Reset condition | Power On Reset |
| Secure 3:0 | Description | Secured bits based on write bits |
| | | secured_3 = NOT(bit5) Secured_2= NOT(bit4) Secured_1=bit7 Secured_0=bit6 |

IO_OUT-AMUX

Table 54. IO_OUT-AMUX Register Description

| Write | | | | | | | | | | | | | | | | |
|-------|-------|-------|-------|-----------|-------|--------|---------|-----------|-------------|------------|-------------|----------|-----------|--------|--------|--------|
| | bit15 | bit14 | bit13 | bit12 | bit11 | bit10 | bit9 | bit8 | bit7 | bit6 | bit5 | bit4 | bit3 | bit2 | bit1 | bit0 |
| MOSI | 1 | 0 | 1 | 0 | 1 | 1 | 1 | P | IO_out_4_EN | IO_out_4 | IO_out_5_EN | IO_out_5 | Reserv ed | Amux_2 | Amux_1 | Amux_0 |
| Read | | | | | | | | | | | | | | | | |
| | bit15 | bit14 | bit13 | bit12 | bit11 | bit10 | bit9 | bit8 | bit7 | bit6 | bit5 | bit4 | bit3 | bit2 | bit1 | bit0 |
| MOSI | 0 | 0 | 1 | 0 | 1 | 1 | 1 | 0 | 0 | 0 | 0 | 0 | 0 | 0 | 0 | 0 |
| MISO | SPI_G | WU | CAN_G | Reserv ed | IO_G | Vpre_G | Vcore_G | Vothers_G | IO_out_4_EN | IO_oo ut_4 | IO_out_5_EN | IO_out_5 | Reserv ed | Amux_2 | Amux_1 | Amux_0 |

Table 55. IO_OUT-AMUX. Description and Configuration of the Bits (Default value in blue)

| | | |
|-------------|-----------------|---|
| IO_out_4_EN | Description | Enable the output gate driver capability for IO_4 |
| | 0 | High impedance (IO_4 configured as input) |
| | 1 | ENABLED (IO_4 configured as output gate driver) |
| | Reset condition | Power On Reset |
| IO_out_4 | Description | Configure IO_4 output gate driver state |
| | 0 | LOW |
| | 1 | HIGH |
| | Reset condition | Power On Reset |
| IO_out_5_EN | Description | Enable the output gate driver capability for IO_5 |
| | 0 | High impedance (IO_5 configured as input) |
| | 1 | ENABLED (IO_5 configured as output gate driver) |
| | Reset condition | Power On Reset |
| IO_out_5 | Description | Configure IO_5 output gate driver state |
| | 0 | LOW |
| | 1 | HIGH |
| | Reset condition | Power On Reset |
| AMUX_2:0 | Description | Select AMUX output |
| | 000 | Vref |
| | 001 | Vsns wide range |
| | 010 | IO_0 wide range |
| | 011 | IO_1 wide range |
| | 100 | Vsns tight range |
| | 101 | IO_0 tight range |
| | 110 | IO_1 tight range |
| | 111 | Die temp. Sense |
| | Reset condition | Power On Reset |

CAN MODE

Table 56. CAN MODE Register Description

| Write | | | | | | | | | | | | | | | | |
|-------|-------|-------|-------|----------|-------|--------|-------------|---------------|----------------|----------------|------------------|--------------|--------------|--------------|------------|--------------|
| | bit15 | bit14 | bit13 | bit12 | bit11 | bit10 | bit9 | bit8 | bit7 | bit6 | bit5 | bit4 | bit3 | bit2 | bit1 | bit0 |
| MOSI | 1 | 0 | 1 | 1 | 0 | 0 | 0 | P | CAN_m ode_1 | CAN_m ode_0 | CAN_a uto_dis | reserve d | reserve d | reserve d | 0 | 0 |
| MISO | SPI_G | WU | CAN_G | Reserved | IO_G | Vpre_G | Vcore_ G | Vothers _G | CAN_m ode_1 | CAN_m ode_0 | CAN_a uto_dis | reserve d | reserve d | reserve d | CAN_w u | reserve d |
| Read | | | | | | | | | | | | | | | | |
| | bit15 | bit14 | bit13 | bit12 | bit11 | bit10 | bit9 | bit8 | bit7 | bit6 | bit5 | bit4 | bit3 | bit2 | bit1 | bit0 |
| MOSI | 0 | 0 | 1 | 1 | 0 | 0 | 0 | 0 | 0 | 0 | 0 | 0 | 0 | 0 | 0 | 0 |
| MISO | SPI_G | WU | CAN_G | Reserved | IO_G | Vpre_G | Vcore_ G | Vothers _G | CAN_m ode_1 | CAN_m ode_0 | CAN_a uto_dis | reserve d | reserve d | reserve d | CAN_w u | reserve d |

Table 57. CAN MODE. Description and Configuration of the Bits (Default value in blue)

| | | |
|--------------|-----------------|--|
| CAN_mode_1:0 | Description | Configure the CAN mode |
| | 00 | Sleep / NO wake up capability |
| | 01 | LISTEN ONLY |
| | 10 | Sleep / Wake-up capability |
| | 11 | Normal operation mode |
| | Reset condition | Power On Reset |
| CAN_auto_dis | Description | Automatic CAN Tx disable |
| | 0 | NO auto disable |
| | 1 | Reset CAN_mode from "11" to "01" on CAN over temp or TXD dominant or RXD recessive event |
| | Reset condition | Power On Reset |
| CAN_wu | Description | Report a wake up event from the CAN |
| | 0 | No wake-up |
| | 1 | wake-up detected |
| | Reset condition | Power On Reset / Read |

Notes

- When the device is in Normal mode, the CAN mode bits cannot be read back by the SPI when the CAN transceiver is configured in Low Power mode.
- CAN mode is automatically configured to "sleep + wake-up capability [10]" if CAN mode was different than "sleep + no wake-up capability [00]" before the device enters in LPOFF. After LPOFF, the initial CAN mode prior to enter LPOFF is restored.

CAN_MODE_2

Table 58. CAN_MODE_2 Register Description

| Write | | | | | | | | | | | | | | | | |
|-------|-------|-------|-------|--------------|-------|--------|-------------|---------------|--------------|--------------|--------------|---------------------|---------------------|--------------|--------------|--------------|
| | bit15 | bit14 | bit13 | bit12 | bit11 | bit10 | bit9 | bit8 | bit7 | bit6 | bit5 | bit4 | bit3 | bit2 | bit1 | bit0 |
| MOSI | 1 | 0 | 1 | 1 | 0 | 0 | 1 | P | reserve d | reserve d | reserve d | Vcan_ OV_Mo n | secure _3 | secure _2 | secure _1 | secure _0 |
| MISO | SPI_G | WU | CAN_G | Reserv ed | IO_G | Vpre_G | Vcore_ G | Vothers _G | Reserv ed | Reserv ed | Reserv ed | Reserv ed | Vcan_ OV_Mo n | Reserv ed | Reserv ed | Reserv ed |

| Read | | | | | | | | | | | | | | | | |
|------|-------|-------|-------|--------------|-------|--------|-------------|---------------|--------------|--------------|--------------|--------------|---------------------|--------------|--------------|--------------|
| | bit15 | bit14 | bit13 | bit12 | bit11 | bit10 | bit9 | bit8 | bit7 | bit6 | bit5 | bit4 | bit3 | bit2 | bit1 | bit0 |
| MOSI | 0 | 0 | 1 | 1 | 0 | 0 | 1 | 0 | 0 | 0 | 0 | 0 | 0 | 0 | 0 | 0 |
| MISO | SPI_G | WU | CAN_G | Reserv ed | IO_G | Vpre_G | Vcore_ G | Vothers _G | Reserv ed | Reserv ed | Reserv ed | Reserv ed | Vcan_ OV_Mo n | Reserv ed | Reserv ed | Reserv ed |

Table 59. CAN_MODE_2. Description and Configuration of the Bits (Default value in blue)

| | | |
|-------------|-----------------|---|
| Vcan_OV_Mon | Description | VCAN OV Monitoring |
| | 0 | OFF. Vcan OV is not monitored. Flag is ignored |
| | 1 | ON. Vcan OV flag is under monitoring. In case of OV the Vcan regulator is switched OFF. |
| | Reset condition | Power On Reset |
| Secure 3:0 | Description | Secured bits based on write bits |
| | | secured_3 = NOT(bit5) Secured_2= NOT(bit4) Secured_1=bit7 Secured_0=bit6 |

INIT SUPERVISOR1

Table 60. INIT SUPERVISOR1 Register Description

| Write | | | | | | | | | | | | | | | | |
|-------|-------|-------|-----------|-------|--------|---------|-----------|------------|------------|------------|---------------|-----------|------------|-----------|-----------|----------|
| | bit15 | bit14 | bit13 | bit12 | bit11 | bit10 | bit9 | bit8 | bit7 | bit6 | bit5 | bit4 | bit3 | bit2 | bit1 | bit0 |
| MOSI | 1 | 1 | 0 | 0 | 0 | 0 | 1 | P | Vcore_FS1 | Vcore_FS_0 | Vcca_FS_1 | Vcca_FS_0 | secure_3 | Secure_2 | Secure_1 | Secure_0 |
| Read | | | | | | | | | | | | | | | | |
| | bit15 | bit14 | bit13 | bit12 | bit11 | bit10 | bit9 | bit8 | bit7 | bit6 | bit5 | bit4 | bit3 | bit2 | bit1 | bit0 |
| MOSI | 0 | 1 | 0 | 0 | 0 | 0 | 1 | 0 | 0 | 0 | 0 | 0 | 0 | 0 | 0 | 0 |
| MISO | | | | | | | | | | | | | | | | |
| SPI_G | WU | CAN_G | Reserv ed | IO_G | Vpre_G | Vcore_G | Vothers_G | SPI_FS_err | SPI_FS_CLK | SPI_FS_Req | SPI_FS_Parity | Vcore_FS1 | Vcore_FS_0 | Vcca_FS_1 | Vcca_FS_0 | |

Table 61. INIT SUPERVISOR1. Description and Configuration of the Bits (Default value in blue)

| | | |
|-------------|-----------------|--|
| Vcore_FS1:0 | Description | Vcore safety input. |
| | 00 | No effect of Vcore_OV and Vcore_uv on RSTb and FSxx |
| | 01 | Vcore_OV DOES HAVE an impact on RSTb and FSxx. Vcore_UV DOES HAVE an impact on RSTb only |
| | 10 | Vcore_OV DOES HAVE an impact on RSTb and FSxx. No effect of Vcore_UV on RSTb and FSxx |
| | 11 | Both Vcore_OV and Vcore_UV DO HAVE an impact on RSTb and FSxx |
| | Reset condition | Power On Reset |
| Vcca_FS1:0 | Description | Vcca safety input. |
| | 00 | No effect of Vcca_OV and Vcca_uv on RSTb and FSxx |
| | 01 | Vcca_OV DOES HAVE an impact on RSTb and FSxx. Vcca_UV DOES HAVE an impact on RSTb only |
| | 10 | Vcca_OV DOES HAVE an impact on RSTb and FSxx. No effect of Vcca_UV on RSTb and FSxx |
| | 11 | Both Vcca_OV and Vcca_UV DO HAVE an impact on RSTb and FSxx |
| | Reset condition | Power On Reset |
| Secure3:0 | Description | Secured bits based on write bits |
| | | secured_3 = NOT(bit5) Secured_2= NOT(bit4) Secured_1=bit7 Secured_0=bit6 |
| SPI_FS_err | Description | Secured SPI communication check |
| | 0 | No error |
| | 1 | Error detected in the secured bits |
| | Reset condition | Power On Reset |
| SPI_FS_CLK | Description | SCLK error detection, concerns internal error in Fail-safe logic only and external errors (at pin level) for both Main and Fail-safe logics. Other errors flagged by SPI_CLK_bit |
| | 0 | 16 clock cycles during NCS low |
| | 1 | Wrong number of clock cycles (<16 or >16) |
| | Reset condition | Power On Reset |

Table 61. INIT SUPERVISOR1. Description and Configuration of the Bits (Default value in blue)

| | | |
|---------------|-----------------|---|
| SPI_FS_Req | Description | Invalid SPI access (Wrong Write or Read, Write to INIT registers in normal mode, wrong address), concerns Fail-safe logic only. |
| | 0 | No error |
| | 1 | SPI violation |
| | Reset condition | Power On Reset |
| SPI_FS_Parity | Description | SPI parity bit error detection, concerns Fail-safe logic only |
| | 0 | Parity bit OK |
| | 1 | Parity bit ERROR |
| | Reset condition | Power On Reset |

INIT SUPERVISOR 2

Table 62. INIT SUPERVISOR2 Register Description

| Write | | | | | | | | | | | | | | | | |
|-------|-------|-------|-------|----------|-------|--------|---------|-----------|------------|------------|------------|---------------|----------|----------|----------|----------|
| | bit15 | bit14 | bit13 | bit12 | bit11 | bit10 | bit9 | bit8 | bit7 | bit6 | bit5 | bit4 | bit3 | bit2 | bit1 | bit0 |
| MOSI | 1 | 1 | 0 | 0 | 0 | 1 | 0 | P | Vaux_FS1 | Vaux_FS0 | 0 | DIS_8s | Secure_3 | Secure_2 | Secure_1 | Secure_0 |
| MISO | SPI_G | WU | CAN_G | Reserved | IO_G | Vpre_G | Vcore_G | Vothers_G | SPI_FS_err | SPI_FS_CLK | SPI_FS_req | SPI_FS_Parity | 0 | DIS_8s | Vaux_FS1 | Vaux_FS0 |

| Read | | | | | | | | | | | | | | | | |
|------|-------|-------|-------|----------|-------|--------|---------|-----------|------------|------------|------------|---------------|------|--------|----------|----------|
| | bit15 | bit14 | bit13 | bit12 | bit11 | bit10 | bit9 | bit8 | bit7 | bit6 | bit5 | bit4 | bit3 | bit2 | bit1 | bit0 |
| MOSI | 0 | 1 | 0 | 0 | 0 | 1 | 0 | 0 | 0 | 0 | 0 | 0 | 0 | 0 | 0 | 0 |
| MISO | SPI_G | WU | CAN_G | Reserved | IO_G | Vpre_G | Vcore_G | Vothers_G | SPI_FS_err | SPI_FS_CLK | SPI_FS_req | SPI_FS_Parity | 0 | DIS_8s | Vaux_FS1 | Vaux_FS0 |

Table 63. INIT SUPERVISOR2. Description and Configuration of the Bits (Default value in blue)

| | | |
|------------|-----------------|--|
| Vaux_FS1:0 | Description | Vaux safety input. |
| | 00 | No effect of Vaux_OV and Vaux_uv on RSTb and FSxx |
| | 01 | Vaux_OV DOES HAVE an impact on RSTb and FSxx. Vaux_UV DOES HAVE an impact on RSTb only |
| | 10 | Vaux_OV DOES HAVE an impact on RSTb and FSxx. No effect of Vaux_UV on RSTb and FSxx |
| | 11 | Both Vaux_OV and Vaux_UV DO HAVE an impact on RSTb and FSxx |
| | Reset condition | Power On Reset |
| DIS_8s | Description | Disable the 8s timer used to enter Deep FAILSAFE mode |
| | 0 | ENABLED |
| | 1 | DISABLED |
| | Reset condition | Power On Reset |
| Secure3:0 | Description | Secured bits based on write bits |
| | | secured_3 = NOT(bit5) Secured_2= NOT(bit4) Secured_1=bit7 Secured_0=bit6 |
| SPI_FS_err | Description | Secured SPI communication check, concerns Fail-safe logic only. |
| | 0 | No error |
| | 1 | Error detected in the secured bits |
| | Reset condition | Power On Reset |
| SPI_FS_CLK | Description | SCLK error detection, concerns internal error in Fail-safe logic only and external errors (at pin level) for both Main and Fail-safe logics. Other errors flagged by SPI_CLK_bit |
| | 0 | 16 clock cycles during NCS low |
| | 1 | Wrong number of clock cycles (<16 or >16) |
| | Reset condition | Power On Reset |

Table 63. INIT SUPERVISOR2. Description and Configuration of the Bits (Default value in blue)

| | | |
|---------------|-----------------|--|
| SPI_FS_Req | Description | Invalid SPI access (Wrong Write or Read, Write to INIT registers in normal mode, wrong address), concerns Fail-safe Logic only |
| | 0 | No error |
| | 1 | SPI violation |
| | Reset condition | Power On Reset |
| SPI_FS_Parity | Description | SPI parity bit error detection, concerns Fail-safe logic only |
| | 0 | Parity bit OK |
| | 1 | Parity bit ERROR |
| | Reset condition | Power On Reset |

INIT SUPERVISOR 3

Table 64. INIT SUPERVISOR3 Register Description

| Write | | | | | | | | | | | | | | | | |
|-------|-------|-------|-----------|-------|--------|---------|-----------|------------|------------|------------|---------------|------|----------|----------|----------|----------|
| | bit15 | bit14 | bit13 | bit12 | bit11 | bit10 | bit9 | bit8 | bit7 | bit6 | bit5 | bit4 | bit3 | bit2 | bit1 | bit0 |
| MOSI | 1 | 1 | 0 | 0 | 0 | 1 | 1 | P | Vcore_5D | Vcca_5D | Vaux_5D | 0 | Secure_3 | Secure_2 | Secure_1 | Secure_0 |
| Read | | | | | | | | | | | | | | | | |
| | bit15 | bit14 | bit13 | bit12 | bit11 | bit10 | bit9 | bit8 | bit7 | bit6 | bit5 | bit4 | bit3 | bit2 | bit1 | bit0 |
| MOSI | 0 | 1 | 0 | 0 | 0 | 1 | 1 | 0 | 0 | 0 | 0 | 0 | 0 | 0 | 0 | 0 |
| MISO | | | | | | | | | | | | | | | | |
| SPI_G | WU | CAN_G | Reserv ed | IO_G | Vpre_G | Vcore_G | Vothers_G | SPI_FS_err | SPI_FS_CLK | SPI_FS_req | SPI_FS_Parity | 0 | Vcore_5D | Vcca_5D | Vaux_5D | |

Table 65. INIT SUPERVISOR3. Description and Configuration of the Bits (Default value in blue)

| | | |
|------------|-----------------|--|
| Vcore_5D | Description | Configure the Vcore undervoltage in degraded mode. Only valid for 5V |
| | 0 | Normal 5 V undervoltage detection threshold (Vcore_uv) |
| | 1 | Degraded mode, i.e lower under voltage detection threshold applied (Vcore_uv_D) |
| | Reset condition | Power On Reset |
| Vcca_5D | Description | Configure the Vcca undervoltage in degraded mode. Only valid for 5V |
| | 0 | Normal 5 V undervoltage detection threshold (Vcca_uv_5) |
| | 1 | Degraded mode, i.e lower under voltage detection threshold applied (Vcca_uv_D) |
| | Reset condition | Power On Reset |
| Vaux_5D | Description | Configure the Vaux undervoltage in degraded mode. Only valid for 5V |
| | 0 | Normal 5 V undervoltage detection threshold (Vaux_uv_5) |
| | 1 | Degraded mode, i.e lower under voltage detection threshold applied (Vaux_uv_5D) |
| | Reset condition | Power On Reset |
| Secure3:0 | Description | Secured bits based on write bits |
| | | secured_3 = NOT(bit5) Secured_2= NOT(bit4) Secured_1=bit7 Secured_0=bit6 |
| SPI_FS_err | Description | Secured SPI communication check, concerns fail-safe logic only |
| | 0 | No error |
| | 1 | Error detected in the secured bits |
| | Reset condition | Power On Reset |
| SPI_FS_CLK | Description | SCLK error detection, concerns internal error in Fail-safe logic only and external errors (at pin level) for both Main and Fail-safe logics. Other errors flagged by SPI_CLK_bit |
| | 0 | 16 clock cycles during NCS low |
| | 1 | Wrong number of clock cycles (<16 or >16) |
| | Reset condition | Power On Reset |

Table 65. INIT SUPERVISOR3. Description and Configuration of the Bits (Default value in blue)

| | | |
|---------------|-----------------|--|
| SPI_FS_Req | Description | Invalid SPI access (Wrong Write or Read, Write to INIT registers in normal mode, wrong address), concerns Fail-Safe Logic only |
| | 0 | No error |
| | 1 | SPI violation |
| | Reset condition | Power On Reset |
| SPI_FS_Parity | Description | SPI parity bit error detection, concerns Fail-safe logic only |
| | 0 | Parity bit OK |
| | 1 | Parity bit ERROR |
| | Reset condition | Power On Reset |

INIT FSSM1

Table 66. INIT FSSM1 Register Description

| Write | | | | | | | | | | | | | | | | |
|-------|-------|-------|----------|-------|--------|---------|-----------|------------|------------|------------|---------------|----------|----------|----------|----------|----------|
| | bit15 | bit14 | bit13 | bit12 | bit11 | bit10 | bit9 | bit8 | bit7 | bit6 | bit5 | bit4 | bit3 | bit2 | bit1 | bit0 |
| MOSI | 1 | 1 | 0 | 0 | 1 | 0 | 0 | P | IO_01_FS | 0 | IO_45_FS | RSTb_low | Secure_3 | Secure_2 | Secure_1 | Secure_0 |
| Read | | | | | | | | | | | | | | | | |
| | bit15 | bit14 | bit13 | bit12 | bit11 | bit10 | bit9 | bit8 | bit7 | bit6 | bit5 | bit4 | bit3 | bit2 | bit1 | bit0 |
| MOSI | 0 | 1 | 0 | 0 | 1 | 0 | 0 | 0 | 0 | 0 | 0 | 0 | 0 | 0 | 0 | 0 |
| MISO | | | | | | | | | | | | | | | | |
| SPI_G | WU | CAN_G | Reserved | IO_G | Vpre_G | Vcore_G | Vothers_G | SPI_FS_err | SPI_FS_CLK | SPI_FS_req | SPI_FS_Parity | IO_01_FS | 0 | IO_45_FS | RSTb_low | |

Table 67. INIT FSSM1. Description and Configuration of the Bits (Default value in blue)

| | | |
|------------|-----------------|--|
| IO_01_FS | Description | Configure the couple of IO_1:0 as safety inputs |
| | 0 | NOT SAFETY |
| | 1 | SAFETY CRITICAL |
| | Reset condition | Power On Reset |
| IO_45_FS | Description | Configure the couple of IO_5:4 as safety inputs |
| | 0 | NOT SAFETY |
| | 1 | SAFETY CRITICAL |
| | Reset condition | Power On Reset |
| RSTb_low | Description | Configure the Rstb LOW duration time |
| | 0 | 10 ms |
| | 1 | 1ms |
| | Reset condition | Power On Reset |
| Secure3:0 | Description | Secured bits based on write bits |
| | | secured_3 = NOT(bit5) Secured_2= NOT(bit4) Secured_1=bit7 Secured_0=bit6 |
| SPI_FS_err | Description | Secured SPI communication check, concerns Fail-safe logic only |
| | 0 | No error |
| | 1 | Error detected in the secured bits |
| | Reset condition | Power On Reset |
| SPI_FS_CLK | Description | SCLK error detection, concerns internal error in Fail-safe logic only and external errors (at pin level) for both Main and Fail-safe logics. Other errors flagged by SPI_CLK_bit |
| | 0 | 16 clock cycles during NCS low |
| | 1 | Wrong number of clock cycles (<16 or >16) |
| | Reset condition | Power On Reset |

Table 67. INIT FSSM1. Description and Configuration of the Bits (Default value in blue)

| | | |
|---------------|-----------------|--|
| SPI_FS_Req | Description | Invalid SPI access (Wrong Write or Read, Write to INIT registers in normal mode, wrong address), concerns Fail-safe logic only |
| | 0 | No error |
| | 1 | SPI violation |
| | Reset condition | Power On Reset |
| SPI_FS_Parity | Description | SPI parity bit error detection, concerns Fail-safe logic only |
| | 0 | Parity bit OK |
| | 1 | Parity bit ERROR |
| | Reset condition | Power On Reset |

INIT FSSM2

Table 68. INIT FSSM2 Register Description

| Write | | | | | | | | | | | | | | | | |
|-------|-------|-------|-------|-----------|-------|--------|---------|-----------|-------------|------------|------------|---------------|-------------|----------|----------|----------|
| | bit15 | bit14 | bit13 | bit12 | bit11 | bit10 | bit9 | bit8 | bit7 | bit6 | bit5 | bit4 | bit3 | bit2 | bit1 | bit0 |
| MOSI | 1 | 1 | 0 | 0 | 1 | 0 | 1 | P | RSTb_err_FS | IO_23_FS | PS | 0 | Secure_3 | Secure_2 | Secure_1 | Secure_0 |
| MISO | SPI_G | WU | CAN_G | Reserv ed | IO_G | Vpre_G | Vcore_G | Vothers_G | SPI_FS_err | SPI_FS_CLK | SPI_FS_req | SPI_FS_Parity | RSTb_err_FS | IO_23_FS | PS | 0 |

| Read | | | | | | | | | | | | | | | | |
|------|-------|-------|-------|-----------|-------|--------|---------|-----------|------------|------------|------------|---------------|-------------|----------|------|------|
| | bit15 | bit14 | bit13 | bit12 | bit11 | bit10 | bit9 | bit8 | bit7 | bit6 | bit5 | bit4 | bit3 | bit2 | bit1 | bit0 |
| MOSI | 0 | 1 | 0 | 0 | 1 | 0 | 1 | 0 | 0 | 0 | 0 | 0 | 0 | 0 | 0 | 0 |
| MISO | SPI_G | WU | CAN_G | Reserv ed | IO_G | Vpre_G | Vcore_G | Vothers_G | SPI_FS_err | SPI_FS_CLK | SPI_FS_req | SPI_FS_Parity | RSTb_err_FS | IO_23_FS | PS | 0 |

Table 69. INIT FSSM2. Description and Configuration of the Bits (Default value in blue)

| | | |
|-------------|-----------------|--|
| IO_23_FS | Description | Configure the couple of IO_3:2 as safety inputs for FCCU monitoring |
| | 0 | NOT SAFETY |
| | 1 | SAFETY CRITICAL |
| | Reset condition | Power On Reset |
| RSTb_err_FS | Description | Configure the values of the RSTb error counter |
| | 0 | intermediate=3; final=6 |
| | 1 | intermediate=1; final=2 |
| | Reset condition | Power On Reset |
| PS | Description | Configure the Fccu polarity |
| | 0 | Fccu_eaout_1:0 active HIGH |
| | 1 | Fccu_eaout_1:0 active LOW |
| | Reset condition | Power On Reset |
| Secure3:0 | Description | Secured bits based on write bits |
| | | secured_3 = NOT(bit5) Secured_2= NOT(bit4) Secured_1=bit7 Secured_0=bit6 |
| SPI_FS_err | Description | Secured SPI communication check, concerns Fail-safe logic only |
| | 0 | No error |
| | 1 | Error detected in the secured bits |
| | Reset condition | Power On Reset |
| SPI_FS_CLK | Description | SCLK error detection, concerns internal error in Fail-safe logic only and external errors (at pin level) for both Main and Fail-safe logics. Other errors flagged by SPI_CLK_bit |
| | 0 | 16 clock cycles during NCS low |
| | 1 | Wrong number of clock cycles (<16 or >16) |
| | Reset condition | Power On Reset |

Table 69. INIT FSSM2. Description and Configuration of the Bits (Default value in blue)

| | | |
|---------------|-----------------|--|
| SPI_FS_Req | Description | Invalid SPI access (Wrong Write or Read, Write to INIT registers in normal mode, wrong address), concerns Fail-safe Logic only |
| | 0 | No error |
| | 1 | SPI violation |
| | Reset condition | Power On Reset |
| SPI_FS_Parity | Description | SPI parity bit error detection, concerns Fail-safe logic only |
| | 0 | Parity bit OK |
| | 1 | Parity bit ERROR |
| | Reset condition | Power On Reset |

WD WINDOW

Table 70. WD WINDOW Register Description

Write

| | bit15 | bit14 | bit13 | bit12 | bit11 | bit10 | bit9 | bit8 | bit7 | bit6 | bit5 | bit4 | bit3 | bit2 | bit1 | bit0 |
|------|-------|-------|-------|--------------|-------|--------|-------------|---------------|----------------|----------------|----------------|-------------------|----------------|----------------|----------------|----------------|
| MOSI | 1 | 1 | 0 | 0 | 1 | 1 | 0 | P | WD_wi ndow3 | WD_wi ndow2 | WD_wi ndow1 | WD_wi ndow0 | Secure _3 | Secure _2 | Secure _1 | Secure _0 |
| MISO | SPI_G | WU | CAN_G | Reserv ed | IO_G | Vpre_G | Vcore_ G | Vothers _G | SPI_FS _err | SPI_FS _CLK | SPI_FS _req | SPI_FS _Parity | WD_wi ndow3 | WD_wi ndow2 | WD_wi ndow1 | WD_wi ndow0 |

Read

| | bit15 | bit14 | bit13 | bit12 | bit11 | bit10 | bit9 | bit8 | bit7 | bit6 | bit5 | bit4 | bit3 | bit2 | bit1 | bit0 |
|------|-------|-------|-------|--------------|-------|--------|-------------|---------------|----------------|----------------|----------------|-------------------|----------------|----------------|----------------|----------------|
| MOSI | 0 | 1 | 0 | 0 | 1 | 1 | 0 | 0 | 0 | 0 | 0 | 0 | 0 | 0 | 0 | 0 |
| MISO | SPI_G | WU | CAN_G | Reserv ed | IO_G | Vpre_G | Vcore_ G | Vothers _G | SPI_FS _err | SPI_FS _CLK | SPI_FS _req | SPI_FS _Parity | WD_wi ndow3 | WD_wi ndow2 | WD_wi ndow1 | WD_wi ndow0 |

Any WRITE command to the WD_window in the Normal mode must be followed by a READ command to verify the correct change of the WD window duration

Table 71. WD Window. Description and Configuration of the Bits (Default value in blue)

| | | |
|-----------------|----------------|---|
| WD_Window_3:0 | Description | Configure the watchdog window duration. Duty cycle if set to 50% |
| | 0000 | DISABLE |
| | 0001 | 1 ms |
| | 0010 | 2 ms |
| | 0011 | 3 ms |
| | 0100 | 4 ms |
| | 0101 | 6 ms |
| | 0110 | 8 ms |
| | 0111 | 12 ms |
| | 1000 | 16 ms |
| | 1001 | 24 ms |
| | 1010 | 32 ms |
| | 1011 | 64 ms |
| | 1100 | 128 ms |
| | 1101 | 256 ms |
| | 1110 | 512 ms |
| | 1111 | 1024 ms |
| Reset condition | Power On Reset | |
| Secure3:0 | Description | Secured bits based on write bits |
| | | secured_3 = NOT(bit5) Secured_2= NOT(bit4) Secured_1=bit7 Secured_0=bit6 |

Table 71. WD Window. Description and Configuration of the Bits (Default value in blue)

| | | |
|---------------|-----------------|---|
| SPI_FS_err | Description | Secured SPI communication check, concerns Fail-safe logic only |
| | 0 | No error |
| | 1 | Error detected in the secured bits |
| | Reset condition | Power On Reset |
| SPI_FS_CLK | Description | SCLK error detection, concerns internal error in Fail-safe logic only and external errors (at pin level) for both Main and Fail-safe logics. Other errors flagged by SPI_CLK bit. |
| | 0 | 16 clock cycles during NCS low |
| | 1 | Wrong number of clock cycles (<16 or >16) |
| | Reset condition | Power On Reset |
| SPI_FS_Req | Description | Invalid SPI access (Wrong Write or Read, Write to INIT registers in normal mode, wrong address), concerns Fail-safe logic only |
| | 0 | No error |
| | 1 | SPI violation |
| | Reset condition | Power On Reset |
| SPI_FS_Parity | Description | SPI parity bit error detection, concerns Fail-safe logic only |
| | 0 | Parity bit OK |
| | 1 | Parity bit ERROR |
| | Reset condition | Power On Reset |

WD_LFSR

Table 72. WD LFSR Register Description

| Write | | | | | | | | | | | | | | | | |
|-------|-------|-------|-------|----------|-------|--------|---------|-----------|------------|------------|------------|------------|------------|------------|------------|------------|
| | bit15 | bit14 | bit13 | bit12 | bit11 | bit10 | bit9 | bit8 | bit7 | bit6 | bit5 | bit4 | bit3 | bit2 | bit1 | bit0 |
| MOSI | 1 | 1 | 0 | 0 | 1 | 1 | 1 | P | WD_LF SR_7 | WD_LF SR_6 | WD_LF SR_5 | WD_LF SR_4 | WD_LF SR_3 | WD_LF SR_2 | WD_LF SR_1 | WD_LF SR_0 |
| MISO | SPI_G | WU | CAN_G | Reserved | IO_G | Vpre_G | Vcore_G | Vothers_G | 0 | 0 | 0 | 0 | 0 | 0 | 0 | 0 |

| Read | | | | | | | | | | | | | | | | |
|------|-------|-------|-------|----------|-------|--------|---------|-----------|------------|------------|------------|------------|------------|------------|------------|------------|
| | bit15 | bit14 | bit13 | bit12 | bit11 | bit10 | bit9 | bit8 | bit7 | bit6 | bit5 | bit4 | bit3 | bit2 | bit1 | bit0 |
| MOSI | 0 | 1 | 0 | 0 | 1 | 1 | 1 | 0 | 0 | 0 | 0 | 0 | 0 | 0 | 0 | 0 |
| MISO | SPI_G | WU | CAN_G | Reserved | IO_G | Vpre_G | Vcore_G | Vothers_G | WD_LF SR_7 | WD_LF SR_6 | WD_LF SR_5 | WD_LF SR_4 | WD_LF SR_3 | WD_LF SR_2 | WD_LF SR_1 | WD_LF SR_0 |

Table 73. WD LFSR. Description and Configuration of the Bits (Default value in blue)

| WD_LFSR_7:0 | Description | WD 8 bits LFSR value. Used to write the seed at any time |
|-----------------|-------------|--|
| 0... | | bit7:bit0: 10110010 default value at startup or after a Power on reset: 0xB2 ⁽²¹⁾ |
| 1... | | |
| Reset condition | | Power On Reset |

Notes

21. Value Bit7:Bit0: 1111 1111 is prohibited.

WD ANSWER

Table 74. WD ANSWER Register Description

| Write | | | | | | | | | | | | | | | | |
|-------|-------|-------|-------|----------|-------|--------|---------|-----------|-------------|-------------|-------------|-------------|-------------|-------------|-------------|-------------|
| | bit15 | bit14 | bit13 | bit12 | bit11 | bit10 | bit9 | bit8 | bit7 | bit6 | bit5 | bit4 | bit3 | bit2 | bit1 | bit0 |
| MOSI | 1 | 1 | 0 | 1 | 0 | 0 | 0 | P | WD_answer_7 | WD_answer_6 | WD_answer_5 | WD_answer_4 | WD_answer_3 | WD_answer_2 | WD_answer_1 | WD_answer_0 |
| Read | | | | | | | | | | | | | | | | |
| | bit15 | bit14 | bit13 | bit12 | bit11 | bit10 | bit9 | bit8 | bit7 | bit6 | bit5 | bit4 | bit3 | bit2 | bit1 | bit0 |
| MOSI | 0 | 1 | 0 | 1 | 0 | 0 | 0 | 0 | 0 | 0 | 0 | 0 | 0 | 0 | 0 | 0 |
| MISO | SPI_G | WU | CAN_G | Reserved | IO_G | Vpre_G | Vcore_G | Vothers_G | RSTb | FS0 | WD | FS0_G | IO_FS_G | 0 | FS_EC_C | FS_reg_Ecc |

Table 75. WD answer. Description and Configuration of the Bits (Default value in blue)

| | | |
|---------------|-----------------|---|
| WD_answer_7:0 | Description | WD answer from the MCU |
| | 0... | Answer = (NOT(((LFSR x 4)+6)-4))/4 |
| | 1... | |
| | Reset condition | Power On Reset / RSTb LOW |
| RSTb | Description | Report a reset event |
| | 0 | No Reset |
| | 1 | Reset occurred |
| | Reset condition | Power On Reset / Read |
| FS0b | Description | Report a fail-safe event |
| | 0 | No Fail-safe |
| | 1 | Fail safe event occurred / Also default state at power-up after LPOFF as FS0b is asserted low |
| | Reset condition | Power On Reset / Read |
| WD | Description | Report a watchdog refresh ERROR |
| | 0 | WD refresh OK |
| | 1 | WRONG WD refresh |
| | Reset condition | Power On Reset / Read |
| FS0_G | Description | Report a fail-safe output failure |
| | 0 | NO failure |
| | 1 | Failure |
| | Reset condition | Power On Reset / Read |
| IO_FS_G | Description | Report an IO monitoring error |
| | 0 | No error |
| | 1 | Error detected |
| | Reset condition | Power On Reset |

Table 75. WD answer. Description and Configuration of the Bits (Default value in blue)

| | | |
|------------|-----------------|--|
| FS_ECC | Description | Report an error code correction on Fail-safe state machine |
| | 0 | NO ECC |
| | 1 | ECC done |
| | Reset condition | Power On Reset / Read |
| FS_req_ECC | Description | Report an error code correction on Fail-safe registers |
| | 0 | NO ECC |
| | 1 | ECC done |
| | Reset condition | Power On Reset / Read |

FAIL-SAFE OUT (FS_OUT)

Table 76. FAIL-SAFE OUT Register Description

| Write | | | | | | | | | | | | | | | | |
|-------|-------|-------|-------|-----------|-------|--------|---------|-----------|----------|----------|----------|----------|----------|----------|----------|----------|
| | bit15 | bit14 | bit13 | bit12 | bit11 | bit10 | bit9 | bit8 | bit7 | bit6 | bit5 | bit4 | bit3 | bit2 | bit1 | bit0 |
| MOSI | 1 | 1 | 0 | 1 | 0 | 0 | 1 | P | FS_out_7 | FS_out_6 | FS_out_5 | FS_out_4 | FS_out_3 | FS_out_2 | FS_out_1 | FS_out_0 |
| MISO | SPI_G | WU | CAN_G | Reserv ed | IO_G | Vpre_G | Vcore_G | Vothers_G | 0 | 0 | 0 | 0 | 0 | 0 | 0 | 0 |

Table 77. Fail-Safe OUT. Description and Configuration of the Bits (Default value in blue)

| FS_out_7:0 | Description | |
|------------|-----------------|--|
| | 0... | Secured 8 bits word to release the FS0b |
| | 1... | Depend on LFSR_out value and calculation |
| | Reset condition | Power On Reset -> Default = 00h |

RSTB REQUEST

Table 78. RSTb REQUEST register description

| Write | | | | | | | | | | | | | | | | |
|-------|-------|-------|-------|-----------|-------|--------|---------|-----------|------|------|---------------|------|----------|----------|----------|----------|
| | bit15 | bit14 | bit13 | bit12 | bit11 | bit10 | bit9 | bit8 | bit7 | bit6 | bit5 | bit4 | bit3 | bit2 | bit1 | bit0 |
| MOSI | 1 | 1 | 0 | 1 | 0 | 1 | 0 | P | 0 | 0 | RSTb_r equest | 0 | Secure_3 | Secure_2 | Secure_1 | Secure_0 |
| MISO | SPI_G | WU | CAN_G | Reserv ed | IO_G | Vpre_G | Vcore_G | Vothers_G | 0 | 0 | 0 | 0 | 0 | 0 | 0 | 0 |

Table 79. RSTb Request. Description and configuration of the bits (Default value in blue)

| RSTb_request | Description | |
|--------------|-----------------|---|
| | 0 | Request a RSTb low pulse |
| | 1 | No request |
| | 1 | Request a RSTb low pulse |
| | Reset condition | Power On Reset / When RSTb done |
| Secure3:0 | Description | |
| | | Secured bits based on write bits |
| | | secured_3 = NOT(bit5) Secured_2= NOT(bit4) Secured_1=bit7 Secured_0=bit6 |

INIT_WD

Table 80. INIT WD Register Description

| Write | | | | | | | | | | | | | | | | |
|-------|-------|-------|-------|----------|-------|--------|---------|-----------|---------------------------|--------------------------|-------------------------|-------------------------|---------------------------|--------------------------|-------------------------|-------------------------|
| | bit15 | bit14 | bit13 | bit12 | bit11 | bit10 | bit9 | bit8 | bit7 | bit6 | bit5 | bit4 | bit3 | bit2 | bit1 | bit0 |
| MOSI | 1 | 1 | 0 | 1 | 0 | 1 | 1 | P | WD_CNT T_refres h_1 | WD_cnt_ refresh_ 0 | WD_CNT T_error_ 1 | WD_CNT T_error_ 0 | secure3 | secure2 | secure1 | secure0 |
| Read | | | | | | | | | | | | | | | | |
| | bit15 | bit14 | bit13 | bit12 | bit11 | bit10 | bit9 | bit8 | bit7 | bit6 | bit5 | bit4 | bit3 | bit2 | bit1 | bit0 |
| MOSI | 0 | 1 | 0 | 1 | 1 | 0 | 0 | 0 | 0 | 0 | 0 | 0 | 0 | 0 | 0 | 0 |
| MISO | SPI_G | WU | CAN_G | Reserved | IO_G | Vpre_G | Vcore_G | Vothers_G | SPI_FS_err | SPI_FS_CLK | SPI_FS_Req | SPI_FS_Parity | WD_CNT T_refres h_1 | WD_cnt_ refresh_ 0 | WD_CNT T_error_ 1 | WD_CNT T_error_ 0 |

Table 81. INIT WD. Description and Configuration of the Bits (Default value in blue)

| | | |
|--------------------|-----------------|---|
| WD_CNT_error_1:0 | Description | Configure the maximum value of the WD error counter |
| | 00 | 6 |
| | 01 | 6 |
| | 10 | 4 |
| | 11 | 2 |
| | Reset Condition | Power On Reset |
| WD_CNT_refresh_1:0 | Description | Configure the maximum value of the WD refresh counter |
| | 00 | 6 |
| | 01 | 6 |
| | 10 | 4 |
| | 11 | 1 |
| | Reset Condition | Power On Reset |

DIAG FS1

Table 82. DIAG FS1 Register Description

| Read | | | | | | | | | | | | | | | | |
|------|-------|-------|-------|--------------|-------|--------|-------------|---------------|--------------|---------------|------|-----------------|-----------------|------|------|------|
| | bit15 | bit14 | bit13 | bit12 | bit11 | bit10 | bit9 | bit8 | bit7 | bit6 | bit5 | bit4 | bit3 | bit2 | bit1 | bit0 |
| MOSI | 0 | 1 | 0 | 1 | 1 | 0 | 0 | 0 | 0 | 0 | 0 | 0 | 0 | 0 | 0 | 0 |
| MISO | SPI_G | WU | CAN_G | Reserv ed | IO_G | Vpre_G | Vcore_ G | Vothers _G | RSTb_ ext | RSTb_ diag | 0 | FS0b_d iag_1 | FS0b_d iag_0 | 0 | 0 | 0 |

Table 83. Diag FS1. Description and Configuration of the Bits (Default value in blue)

| | | |
|---------------|-----------------|-------------------------------------|
| RSTb_diag | Description | Report a RSTb short-circuit to HIGH |
| | 0 | NO Failure |
| | 1 | short circuit HIGH |
| | Reset condition | Power On Reset / Read |
| RSTb_ext | Description | Report an external RSTb |
| | 0 | No external RSTb |
| | 1 | external RSTb |
| | Reset condition | Power On Reset / Read |
| FS0b_diag_1:0 | Description | Report a failure on FS0b |
| | 00 | No Failure |
| | 01 | Short-circuit LOW / open load |
| | 1X | short-circuit HIGH |
| | Reset condition | Power On Reset / Read |

WD COUNTER

Table 84. WD COUNTER Register Description

| Read | | | | | | | | | | | | | | | | |
|------|-------|-------|-------|-----------|-------|--------|---------|-----------|----------|----------|----------|------|---------------|---------------|---------------|------|
| | bit15 | bit14 | bit13 | bit12 | bit11 | bit10 | bit9 | bit8 | bit7 | bit6 | bit5 | bit4 | bit3 | bit2 | bit1 | bit0 |
| MOSI | 0 | 1 | 0 | 1 | 1 | 0 | 1 | 0 | 0 | 0 | 0 | 0 | 0 | 0 | 0 | 0 |
| MISO | SPI_G | WU | CAN_G | Reserve d | IO_G | Vpre_G | Vcore_G | Vothers_G | WD_err_2 | WD_err_1 | WD_err_0 | 0 | WD_re fresh_2 | WD_ref resh_1 | WD_ref resh_0 | 0 |

Table 85. WD counter. Description and Configuration of the Bits (Default value in blue)

| | | |
|----------------|-----------------|---|
| WD_err_2:0 | Description | Report the value of the watchdog error counter |
| | 000 | From 0 to 5 (6 generates a Reset and this counter is reset to 0) |
| | to 110 | |
| | Reset condition | Power On Reset |
| WD_refresh_2:0 | Description | Report the value of the watchdog refresh counter |
| | 000 | From 0 to 6 (7 generate a decrease of the RST_err_cnt and this counter is reset to 0) |
| | to 111 | |
| | Reset condition | Power On Reset |

DIAG FS2

Table 86. DIAG FS2 Register Description

| Read | | | | | | | | | | | | | | | | |
|------|-------|-------|-------|--------------|-------|--------|-------------|---------------|----------------|----------------|----------------|------|----------------|----------------|------|----------------|
| | bit15 | bit14 | bit13 | bit12 | bit11 | bit10 | bit9 | bit8 | bit7 | bit6 | bit5 | bit4 | bit3 | bit2 | bit1 | bit0 |
| MOSI | 0 | 1 | 0 | 1 | 1 | 1 | 0 | 0 | 0 | 0 | 0 | 0 | 0 | 0 | 0 | 0 |
| MISO | SPI_G | WU | CAN_G | Reserv ed | IO_G | Vpre_G | Vcore_ G | Vothers _G | RSTb_ err_2 | RSTb_ err_1 | RSTb_ err_0 | 0 | IO_45_ fail | IO_23_ fail | 0 | IO_01_ fail |

Table 87. Diag FS1. Description and Configuration of the Bits (Default value in blue)

| | | |
|--------------|--------------------------|--|
| RSTb_err_2:0 | Description | Report the value of the RSTb error counter |
| | 000 001 ... 110 | Error counter is set to 1 by default |
| | Reset condition | Power On Reset |
| | | |
| IO_45_fail | Description | Report an error in the IO_45 protocol |
| | 0 | NO error |
| | 1 | Error detected |
| | Reset condition | Power On Reset / Read |
| IO_23_fail | Description | Report an error in the FCCU protocol |
| | 0 | NO error |
| | 1 | Error detected |
| | Reset condition | Power On Reset / Read |
| IO_01_fail | Description | Report an error in the IO_01 protocol |
| | 0 | NO error |
| | 1 | Error detected |
| | Reset condition | Power On Reset / Read |

8 List of Interruptions and Description

The INTb output pin generates a low pulse when an Interrupt condition occurs. The INTb behavior as well as the pulse duration are set through SPI during INIT phase.

It is possible to mask some Interruption source (see register mapping).

Table 88. Interruptions list

| Event | Description |
|---|--|
| V _{SNS_UV} | Detection of V _{battery} below 8.5V |
| V _{SUP_UV_7} | Detection of V _{SUP} below 7V (after reverse current protection diode) |
| I _{PPF} | Input power feed forward. Based on V _{SUP} and I _{PRE_PEAK} |
| I _{LIM_PRE} | Pre-Regulator Current Limitation |
| T _{WARN_PRE} | Temperature warning on the pass transistor |
| BoB | Return the running state of V _{PRE} converter (Buck or Boost mode) |
| V _{PRE_STATE} (V _{PRE_SMPS_EN}) | Return the activation state of V _{PRE} DC/DC converter |
| V _{PRE_OV} | Report a V _{PRE} overvoltage detection |
| V _{PRE_UV} | Report a V _{PRE} under voltage detection |
| I _{LIM_CORE} | V _{CORE} Current limitation |
| T _{WARN_CORE} | Temperature warning on the pass transistor |
| V _{CORE_STATE} (V _{CORE_SMPS_EN}) | Return the activation state of V _{CORE} DC/DC converter |
| V _{CORE_OV} | Report a V _{CORE} overvoltage detection |
| V _{CORE_UV} | Report a V _{CORE} under voltage detection |
| I _{LIM_CCA} | V _{CCA} Current limitation |
| T _{WARN_CCA} | Temperature warning on the pass transistor (Internal Pass transistor only) |
| TSD _{VCCA} | Temperature shutdown of the VCCA |
| I _{LIM_CCA_OFF} | Current limitation maximum duration expiration. Only used when external PNP connected. |
| V _{CCA_OV} | Report a V _{CCA} overvoltage detection |
| V _{CCA_UV} | Report a V _{CCA} under voltage detection |
| I _{LIM_AUX} | V _{AUX} Current limitation |
| I _{LIM_AUX_OFF} | Current limitation maximum duration expiration. Only used when external PNP connected. |
| V _{AUX_OV} | Report a V _{AUX} overvoltage detection |
| V _{AUX_UV} | Report a V _{AUX} under voltage detection |
| TSD _{VAUX} | Temperature shutdown of the VAUX |
| I _{LIM_CAN} | V _{CAN} Current limitation |
| V _{CAN_OV} | Report a V _{CAN} overvoltage detection |
| V _{CAN_UV} | Report a V _{CAN} under voltage detection |
| TSD _{CAN} | Temperature shutdown on the pass transistor. Auto restart when T _J < (TSD _{CAN} - TSD _{CAN_HYST}). |

Table 88. Interruptions list

| | |
|----------------------|---|
| IO_0 | Report IO_0 digital state change |
| IO_1 | Report IO_1 digital state change |
| IO_2 | Report IO_2 digital state change |
| IO_3 | Report IO_3 digital state change |
| IO_4 | Report IO_4 digital state change |
| IO_5 | Report IO_5 digital state change |
| IO_0_WU | Report IO_0 WU event |
| IO_1_WU | Report IO_1 WU event |
| IO_2_WU | Report IO_2 WU event |
| IO_3_WU | Report IO_3 WU event |
| IO_4_WU | Report IO_4 WU event |
| IO_5_WU | Report IO_5 WU event |
| CANL _{BATT} | CANL short-circuit to battery detection |
| CANL _{GND} | CANL short-circuit to GND detection |
| CANH _{BATT} | CANH short-circuit to battery detection |
| CANH _{GND} | CANH short-circuit to GND detection |
| CAN_WU | Report a CAN wake-up event |
| CAN_OT | CAN overtemperature detection |
| RXD_recessive | CAN RXD recessive clamping detection (short circuit to 5 V) |
| TXD_dominant | CAN TXD dominant clamping detection (short circuit to GND) |
| CAN_dominant | CAN bus dominant clamping detection |
| CAN_OC | CAN overcurrent detection |
| INT_Request | MCU request for an Interrupt pulse |
| SPI_err | Secured SPI communication check |
| SPI_CLK | Report a wrong number of CLK pulse different than 16 during the NCS low pulse in Main state machine |
| SPI_Req | Invalid SPI access (Wrong write or read, write to INIT registers in normal mode, wrong address) |
| SPI_Parity | Report a Parity error in Main state machine |

9 Typical Applications

Archive Information

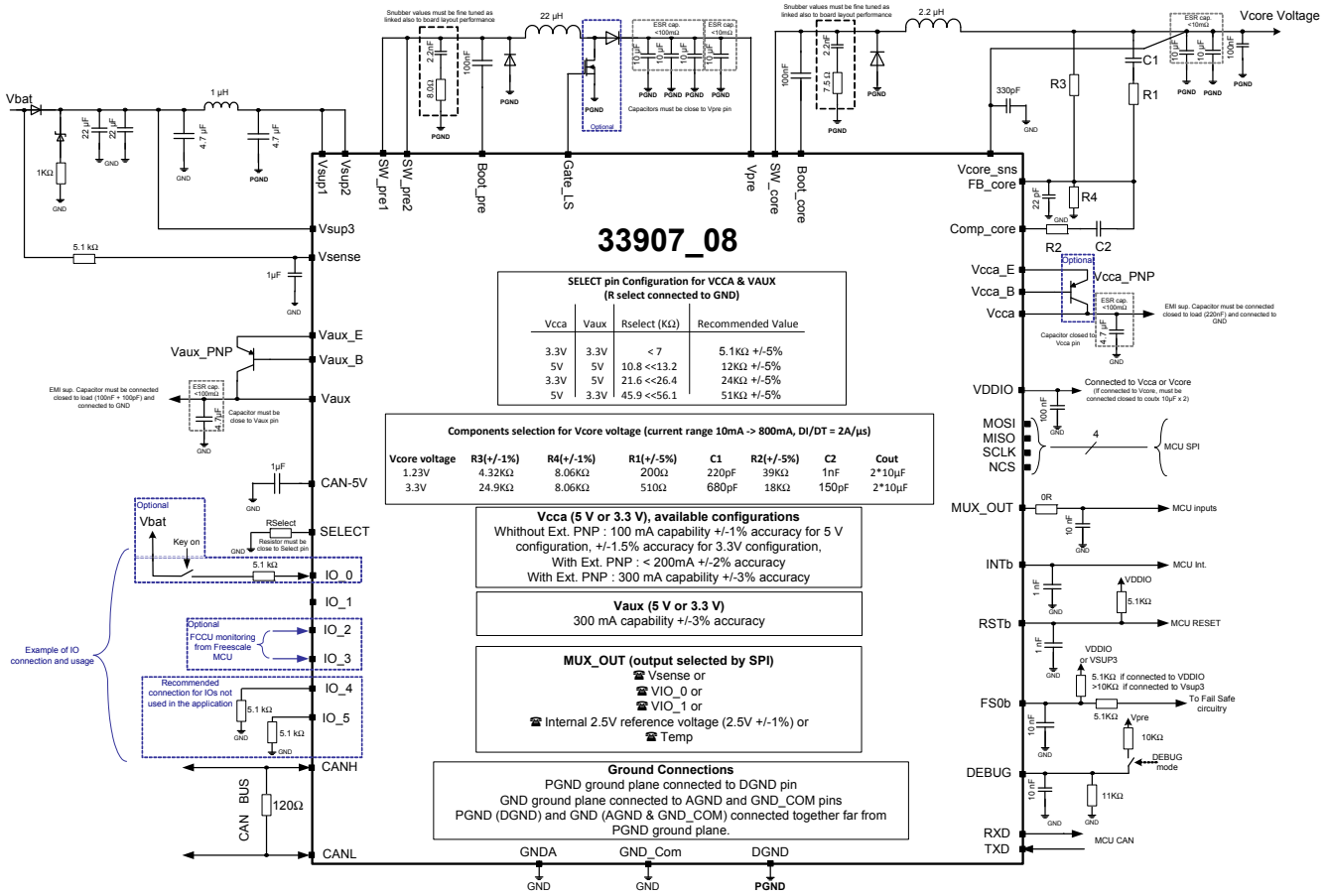

Figure 34. PowerSBC10/20 Simplified Application Schematic with Non-inverting Buck-boost Configuration

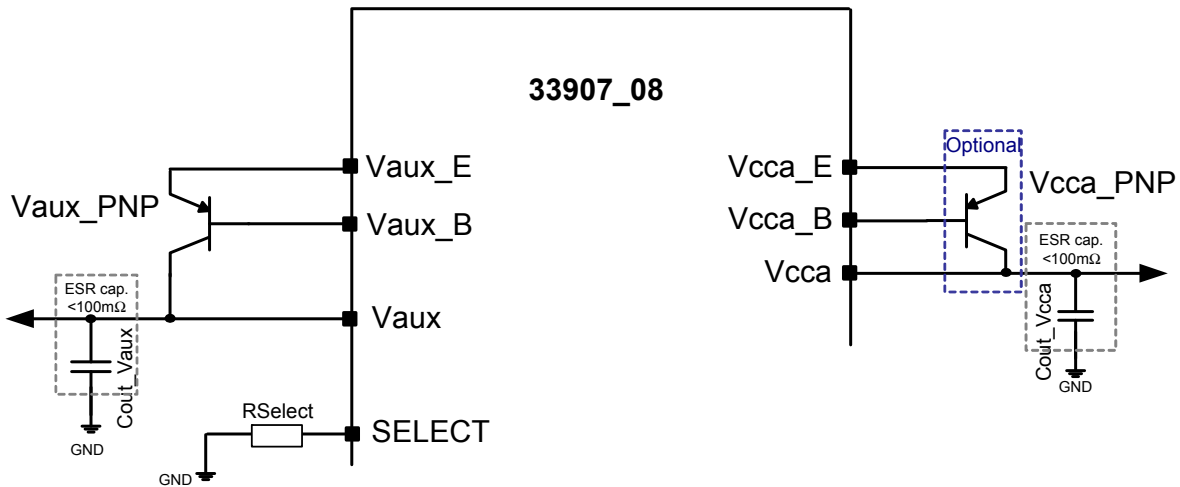

Figure 35. Vaux/Vcca Connection

Archive Information

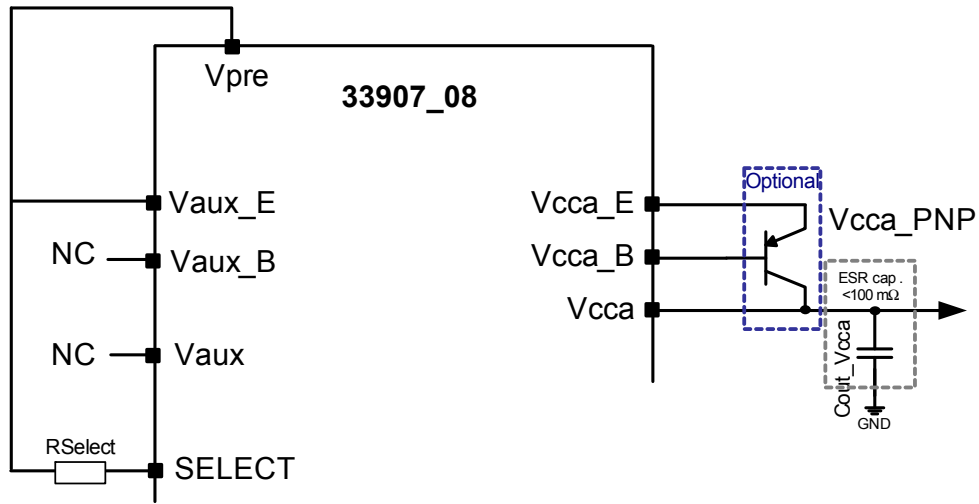

Figure 36. VCCA Connection, Vaux Not Used

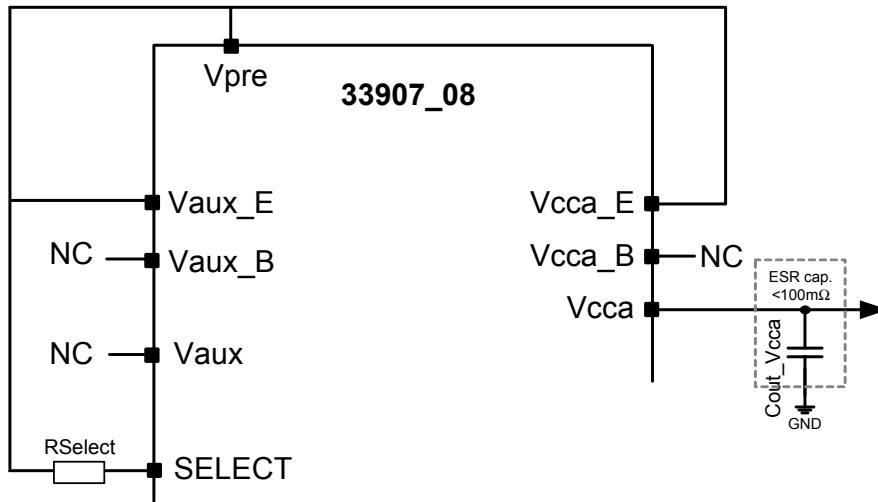

Figure 37. Vaux Not Used, Vcca Configuration up to 100 mA

10 Packaging

10.1 Package Mechanical Dimensions

Package dimensions are provided in package drawings. To find the most current package outline drawing, go to www.freescale.com and perform a keyword search for the drawing's document number.

Table 89. Package Mechanical Dimensions

| Package | Suffix | Package Outline Drawing Number |
|--|--------|--------------------------------|
| 7.0 x 7.0, 48-Pin LQFP Exposed Pad, with 0.5 mm pitch, and a 4.5 x 4.5 exposed pad | AE | 98ASA00173D |

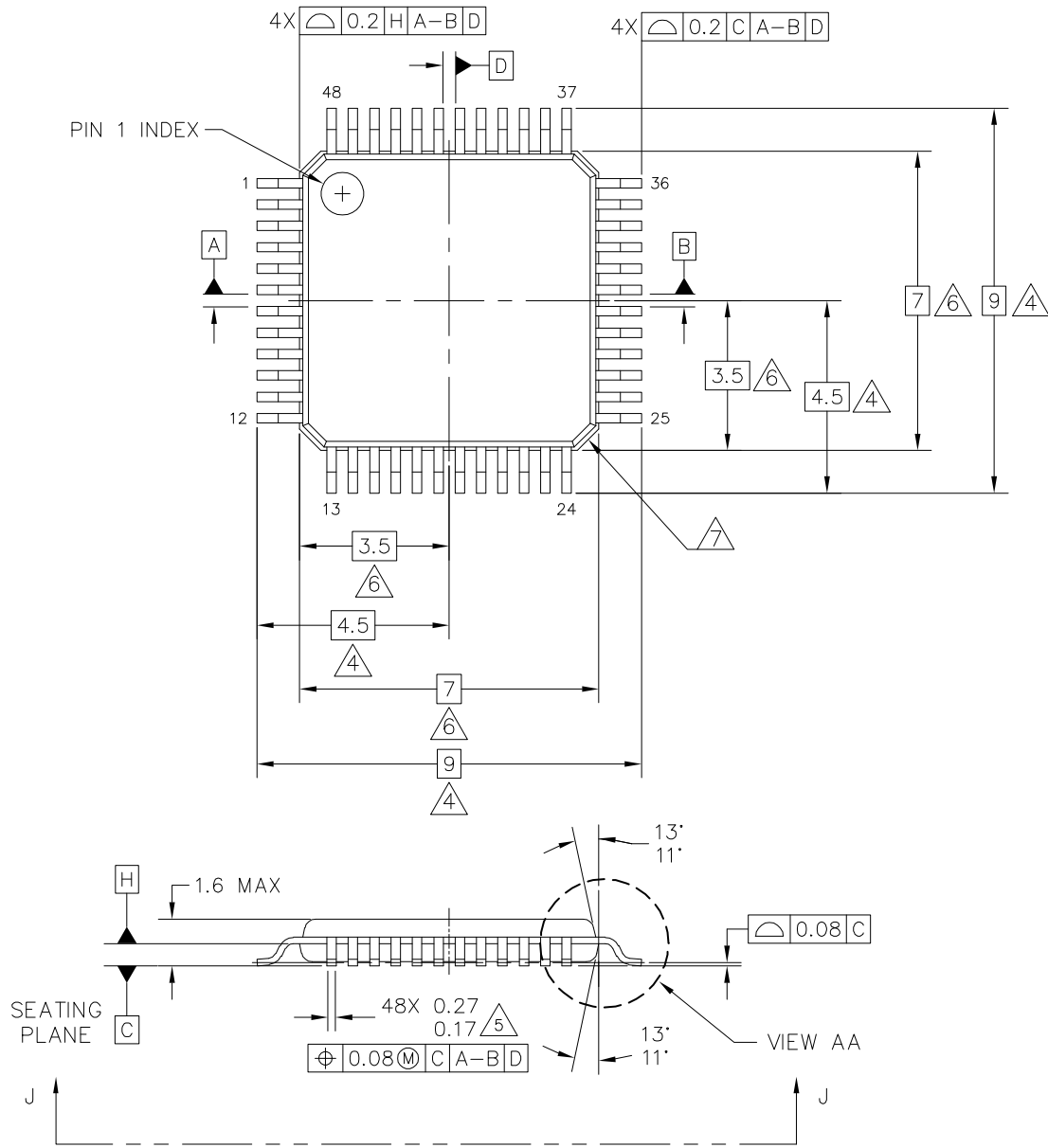

| | | | |
|--|----------------------------|----------------------------|--|
| © FREESCALE SEMICONDUCTOR, INC. ALL RIGHTS RESERVED. | MECHANICAL OUTLINE | PRINT VERSION NOT TO SCALE | |
| TITLE: 48 LEAD LQFP, 7X7X1.4 PKG, 0.5 PITCH, 4.5X4.5 EXPOSED PAD | DOCUMENT NO: 98ASA00173D | REV: A | |
| | CASE NUMBER: 2003-02 | 30 JUN 2011 | |
| | STANDARD: JEDEC MS-026 BBC | | |

AE SUFFIX
48-PIN LQFP-EP
98ASA00173D
ISSUE A

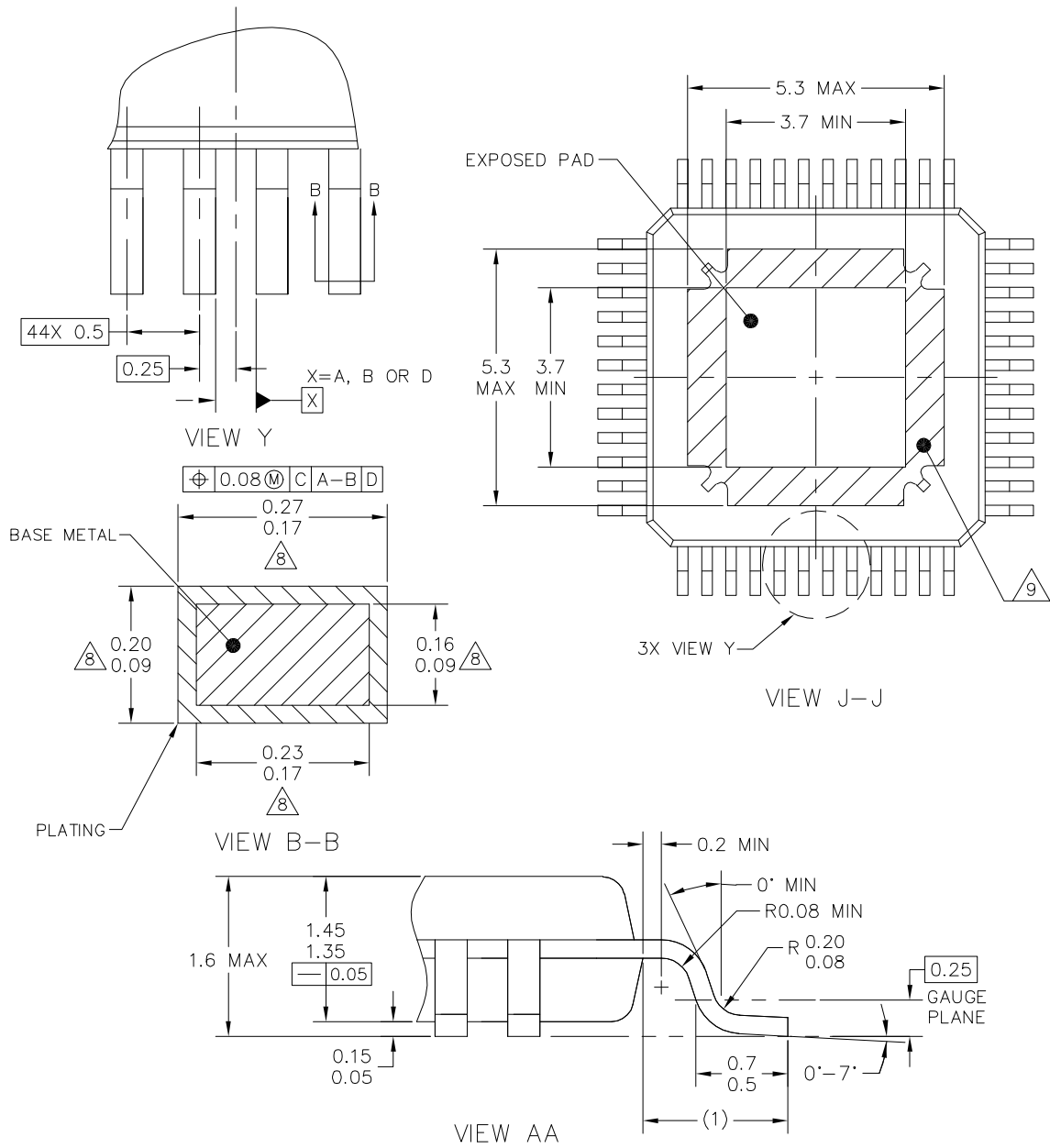

| | | | |
|--|----------------------------|----------------------------|--|
| © FREESCALE SEMICONDUCTOR, INC. ALL RIGHTS RESERVED. | MECHANICAL OUTLINE | PRINT VERSION NOT TO SCALE | |
| TITLE: 48 LEAD LQFP, 7X7X1.4 PKG, 0.5 PITCH, 4.5X4.5 EXPOSED PAD | DOCUMENT NO: 98ASA00173D | REV: A | |
| | CASE NUMBER: 2003-02 | 30 JUN 2011 | |
| | STANDARD: JEDEC MS-026 BBC | | |

AE SUFFIX
48-PIN LQFP-EP
98ASA00173D
ISSUE A

NOTES:

1. DIMENSIONS ARE IN MILLIMETERS.
2. DIMENSIONING AND TOLERANCING PER ASME Y14.5M-1994.
3. DATUMS A, B AND D TO BE DETERMINED AT DATUM PLANE H.
4. DIMENSION TO BE DETERMINED AT SEATING PLANE C.
5. THIS DIMENSION DOES NOT INCLUDE DAMBAR PROTRUSION. ALLOWABLE DAMBAR PROTRUSION SHALL NOT CAUSE THE LEAD WIDTH TO EXCEED THE UPPER LIMIT BY MORE THAN 0.08MM AT MAXIMUM MATERIAL CONDITION. DAMBAR CANNOT BE LOCATED ON THE LOWER RADIUS OR THE FOOT. MINIMUM SPACE BETWEEN PROTRUSION AND ADJACENT LEAD SHALL NOT BE LESS THAN 0.07MM.
6. THIS DIMENSION DOES NOT INCLUDE MOLD PROTRUSION. ALLOWABLE PROTRUSION IS 0.25MM PER SIDE. THIS DIMENSION IS MAXIMUM PLASTIC BODY SIZE DIMENSION INCLUDING MOLD MISMATCH.
7. EXACT SHAPE OF EACH CORNER IS OPTIONAL.
8. THESE DIMENSIONS APPLY TO THE FLAT SECTION OF THE LEAD BETWEEN 0.1MM AND 0.25MM FROM THE LEAD TIP.
9. HATCHED AREA TO BE KEEP OUT ZONE FOR PCB ROUTING.

| | | | |
|--|----------------------------|----------------------------|--|
| © FREESCALE SEMICONDUCTOR, INC. ALL RIGHTS RESERVED. | MECHANICAL OUTLINE | PRINT VERSION NOT TO SCALE | |
| TITLE: 48 LEAD LQFP, 7X7X1.4 PKG, 0.5 PITCH, 4.5X4.5 EXPOSED PAD | DOCUMENT NO: 98ASA00173D | REV: A | |
| | CASE NUMBER: 2003-02 | 30 JUN 2011 | |
| | STANDARD: JEDEC MS-026 BBC | | |

AE SUFFIX
48-PIN LQFP-EP
98ASA00173D
ISSUE A

11 Revision History

| REVISION | DATE | DESCRIPTION OF CHANGES |
|----------|---------|--|
| 1.0 | 11/2013 | <ul style="list-style-type: none"> Initial release |
| 2.0 | 12/2013 | <ul style="list-style-type: none"> Updated Figure 2 Deleted Rk: IO_1 can also be used to monitor a second external resistor bridge (in parallel of the one for V_{CORE} output voltage set) for safety purposes from Table 2 on page 8 Updated Gun Test in Table 3 on page 10 Added IOs maximum current capability to Table 3 on page 10 Updated V_{CCA} voltage in Table 4 on page 14 Updated V_{AUX_LIM_HYST} in Table 4 on page 15 Updated V_{CORE_FB_UV_D} in Table 4 on page 16 Updated V_{AMUX_TP_CO} in Table 4 on page 17 Updated V_{SPI_IL} in Table 4 on page 18 Deleted V_{CORE_FB_DRIFT} Deleted I_{IO_IN1} Deleted t_{RDRIFT} Updated t_{RSTB_POR} in Table 5 on page 22 Added T_{DFS_recovery} time in Table 5 on page 22 Updated DV_{SUP/DT} voltage in Table 5 on page 23 Updated t_{PRE_UV_4p3} in Table 5 on page 24 Updated t_{PRE_TSD}, t_{CORE_TSD}, and t_{CCA_TSD} values in Table 5 on page 24 Updated t_{CAN_TSD} and t_{CAN_UV} values in Table 5 on page 25 Added a formula for temperature sensor Deleted V_{reg_WU} from Table 30 on page 63 Updated Figure 10, Figure 16, Figure 17, and Figure 22 Updated Table 15, Table 16, Table 19, Table 20, Table 27, Table 28, Table 56, Table 67, Table 71, Table 75, and Table 87 Added note ⁽²¹⁾ Updated Figure 34, Figure 35, and Figure 36 Added new Figure 37 Added notes to Table 57 |
| 3.0 | 2/2014 | <ul style="list-style-type: none"> Changed to Advance Information Changed Orderable Parts numbers 33907 and 33908 to MC Added new reference to Table 73 in Normal Operation (First Watchdog Refresh) Changed default in Status Vreg1. Description and Configuration of the Bits (Default value in blue) for Vpre_state, for Vcore_state in Status Vreg2. Description and Configuration of the Bits (Default value in blue), for CAN_mode_1:0 in CAN MODE. Description and Configuration of the Bits (Default value in blue), and RSTb_err_2:0 in Diag FS1. Description and Configuration of the Bits (Default value in blue) Corected SW_PRE pin names |

Archive Information

Archive Information



How to Reach Us:

Home Page:
freescale.com

Web Support:
freescale.com/support

Information in this document is provided solely to enable system and software implementers to use Freescale products. There are no express or implied copyright licenses granted hereunder to design or fabricate any integrated circuits based on the information in this document.

Freescale reserves the right to make changes without further notice to any products herein. Freescale makes no warranty, representation, or guarantee regarding the suitability of its products for any particular purpose, nor does Freescale assume any liability arising out of the application or use of any product or circuit, and specifically disclaims any and all liability, including without limitation consequential or incidental damages. "Typical" parameters that may be provided in Freescale data sheets and/or specifications can and do vary in different applications, and actual performance may vary over time. All operating parameters, including "typicals," must be validated for each customer application by customer's technical experts. Freescale does not convey any license under its patent rights nor the rights of others. Freescale sells products pursuant to standard terms and conditions of sale, which can be found at the following address: freescale.com/SalesTermsandConditions.

Freescale, the Freescale logo, Energy Efficient Solutions logos are trademarks of Freescale Semiconductor, Inc., Reg. U.S. Pat. & Tm. Off. SafeAssure and SMARTMOS, are trademarks of Freescale Semiconductor, Inc. All other product or service names are the property of their respective owners.

© 2014 Freescale Semiconductor, Inc.

Archive Information

Archive Information

Document Number: MC33907_08
Rev. 3.0
2/2014



Mouser Electronics

Authorized Distributor

Click to View Pricing, Inventory, Delivery & Lifecycle Information:

[NXP:](#)

[MC33908AE](#) [MC33907AE](#) [MC33907AER2](#) [MC33908AER2](#) [KIT908-5643EVM](#)