



SILERGY

SA24403

High Efficiency Fast Response, 3.5A, 40V Input Synchronous Step Down Regulator

General Description

The SA24403 develops a high efficiency synchronous step-down DC/DC converter capable of delivering 3.5A load current. The SA24403 operates over a wide input voltage range from 4.2V to 40V and integrates main switch and synchronous switch with very low $R_{DS(ON)}$ to minimize the conduction loss.

The SA24403 adopts peak current control scheme. The switching frequency is adjustable from 300kHz to 2.2MHz using an external resistor. The device also features ultra low quiescent operating to achieve high efficiency under light load. And the internal soft-start limits inrush current during power on.

Ordering Information

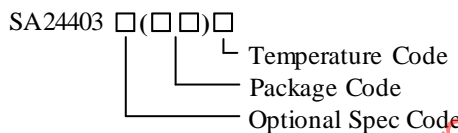

Ordering Number	Package Type	Note
SA24403FCA	SO8E	

Features

- Low $R_{DS(ON)}$ for Internal Switches (Top/Bottom): 115/80m Ω
- 4.2-40V Input Voltage Range
- Internal Compensation
- Internal 1ms Soft-start Limits the Inrush Current
- Adjustable Switching Frequency Range: 300kHz to 2.2MHz
- 3.5A Output Current Capability
- $\pm 2\%$ 0.6V Reference Over -40°C~125°C
- Cycle-by-cycle Peak Current Limitation
- Short Circuit Protection
- Thermal Shutdown and Auto Recovery
- RoHS Compliant and Halogen Free
- Compact Package: SO8E
- Automotive AEC- Q100 Grade 1 certified

Applications

- Automotive
- Industrial
- High-Voltage DC/DC Converters

Typical Application

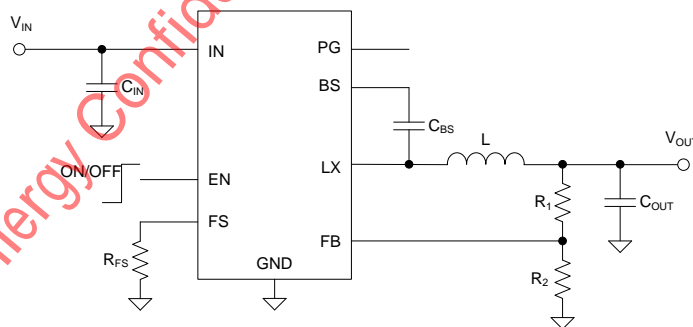

Figure1. Schematic Diagram

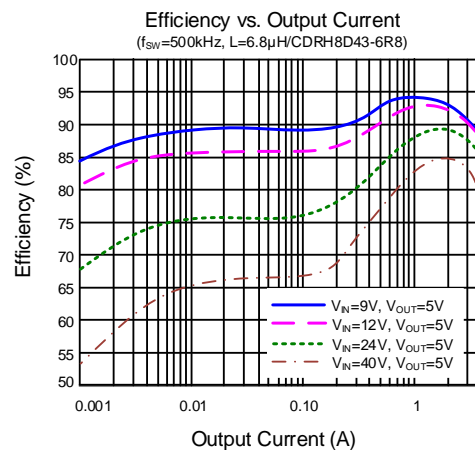
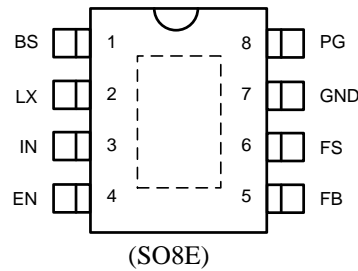

Figure2. Efficiency vs. Output Current

Pinout (Top View)

Top Mark: BTSxyz (device code: BTS, x=year code, y=week code, z=lot number code)

Pin Name	Pin Number	Pin Description
BS	1	Boot-strap pin. Supply high side gate driver. Connect a 0.1μF ceramic capacitor between the BS and the LX pin.
LX	2	Inductor pin. Connect this pin to the switching node of inductor.
IN	3	Input pin. Decouple this pin to GND pin with at least a 4.7μF ceramic capacitor.
EN	4	Enable control. Pull high to turn on. Do not leave it floating.
FB	5	Output feedback pin. Connect this pin to the center point of the output resistor divider (as shown in Figure 1) to program the output voltage: $V_{OUT}=0.6 \times (1+R_1/R_2)$
FS	6	Frequency setting pin. Connect a resistor from this pin to GND to program the switching frequency. The switching frequency equals to: $f_{sw}(kHz) = 10^6 / (9.3 \times R_{FS}(k\Omega) + 30)$
GND	7	Ground.
PG	8	Power good indicator. Open drain output. Externally pulled high when V_{OUT} is within regulation range. Otherwise, internally pulled low.

Block Diagram

Figure3. Block diagram

Absolute Maximum Ratings (Note 1)

IN to GND	-----	-0.3V to 44V
LX, FB, EN, FS, PG to GND	-----	-0.3V to 44V
BS-LX	-----	4V
Power Dissipation, P _D @ T _A = 25°C, SO8E	-----	2.5W
Package Thermal Resistance (Note 2)		
θ _{JA}	-----	40°C/W
θ _{JC}	-----	12°C/W
Junction Temperature Range	-----	-40°C to 150°C
Lead Temperature (Soldering, 10 sec.)	-----	260°C
Storage Temperature Range	-----	-65°C to 150°C

Recommended Operating Conditions (Note 3)

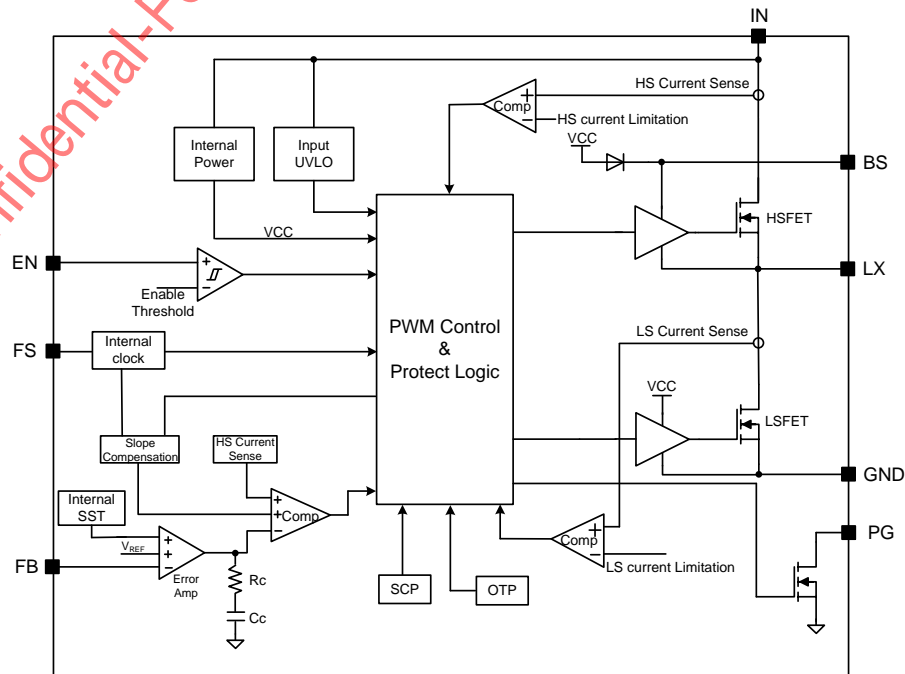
Supply Input Voltage	-----	4.2V to 40V
Ambient Temperature Range	-----	-40°C to 125°C

Silergy Confidential-For Xi'angte Technology Co., Ltd.

Electrical Characteristics

($V_{IN} = 12V$, $T_J = -40^{\circ}C$ to $+125^{\circ}C$. Typical values are at $T_J=25^{\circ}C$, unless otherwise specified. The values are guaranteed by test design or statistical correlation)

Parameter	Symbol	Test Conditions	Min	Typ	Max	Unit
Input Voltage Range	V_{IN}		4.2		40	V
Input UVLO Threshold	V_{UVLO}		3.6	3.9	4.2	V
UVLO Hysteresis	V_{HYS}			0.3		V
Quiescent Current	I_Q	$I_{OUT}=0, V_{FB}=V_{REF}\times 105\%, T_J=25^{\circ}C$	10	18	25	μA
		$I_{OUT}=0, V_{FB}=V_{REF}\times 105\%, T_J=-40^{\circ}C\sim 125^{\circ}C$	5	18	33	
Shutdown Current	I_{SHDN}	$EN=0, T_J=25^{\circ}C$			1	μA
		$EN=0, T_J=-40^{\circ}C\sim 125^{\circ}C$			5	
Feedback Reference Voltage	V_{REF}	$T_J=25^{\circ}C$	0.594	0.6	0.606	V
		$T_J=-40^{\circ}C\sim 125^{\circ}C$	0.588	0.6	0.612	
FB Input Current	I_{FB}	$V_{FB}=0.65V$	-50		50	nA
Top FET RON	$R_{DS(ON)1}$		70	115	210	m Ω
Bottom FET RON	$R_{DS(ON)2}$		45	80	135	m Ω
Top FET Current Limit	$I_{LIM.TOP}$		4.4	5.5	6.6	A
EN High Threshold	V_{ENH}		1.08	1.2	1.32	V
EN Low Threshold	V_{ENL}		0.9	1.0	1.1	V
Hiccup Duty Cycle	D_{HICCUP}			12.5		%
Output Discharge Current	I_{DIS}			45		mA
Oscillator Frequency Program Range	$f_{OSC,RNG}$	$R_{FS}=45.6k\sim 360k$	300		2200	kHz
Oscillator Frequency Accuracy	$f_{OSC,ACC}$	$f_{OSC}=2MHz$, with R_{FS} resistor of 1% accuracy	-12%		12%	f_{OSC}
Output Under Voltage Protection Threshold	V_{UVP}			33%		V_{REF}
Power Good Threshold	V_{PG}	V_{FB} falling, PG from high to low		89%		V_{REF}
		V_{FB} rising, PG from low to high		93%		V_{REF}
		V_{FB} rising, PG from high to low		115%		V_{REF}
		V_{FB} falling, PG from low to high		113%		V_{REF}
PG Delay	$t_{PG,F}$	PG falling edge		10		μs
	$t_{PG,R}$	PG rising edge		150		μs
Power Good Output Low Voltage	$V_{PG,LOW}$	$I_{PG,LOW}=10mA$			0.7	V
Soft-start Time	t_{SS}		0.5	1	2	ms
Min ON Time	$t_{ON,MIN}$			90		ns
Min OFF Time	$t_{OFF,MIN}$	$f_{OSC}=2MHz$		90		ns
Thermal Shutdown Temperature	T_{SD}			160		$^{\circ}C$
Thermal Shutdown Hysteresis	$T_{SD,HYS}$			20		$^{\circ}C$



Note 1: Stresses beyond the “Absolute Maximum Ratings” may cause permanent damage to the device. These are stress ratings only. Functional operation of the device at these or any other conditions beyond those indicated in the operational sections of the specification is not implied. Exposure to absolute maximum rating conditions for extended periods may affect device reliability.

Note 2: θ_{JA} is measured in the natural convection at $T_A = 25^\circ\text{C}$ on a two-layer Silergy demo board.

Note 3: The device is not guaranteed to function outside its operating conditions.

Note 4: High junction temperatures degrade operating lifetime. Operating lifetime is derated for junction temperatures greater than 125°C .

Silergy Confidential-For Xi'angte Technology Co., Ltd.

SO8E Package Outline & PCB Layout

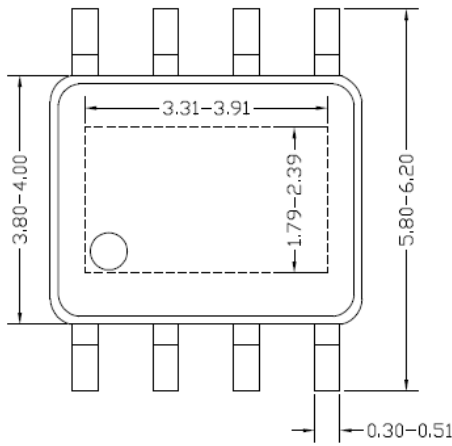

Top view

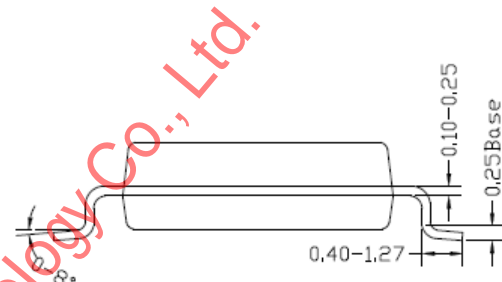

Side view

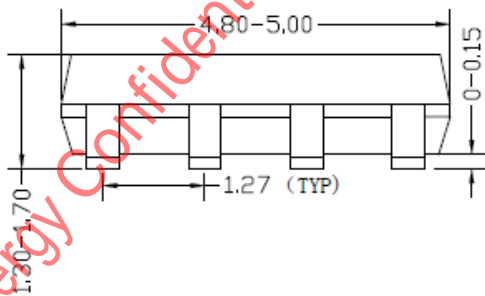

Front view

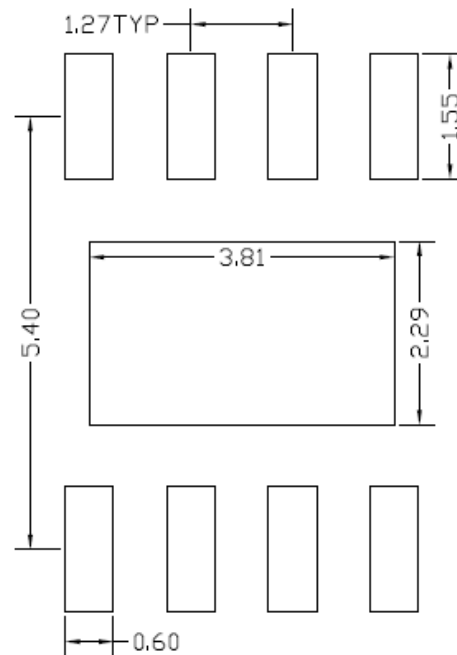

**Recommended PCB Layout
(Reference Only)**

Notes: All dimension in millimeter and exclude mold flash & metal burr.

Taping & Reel Specification

1. Taping orientation

SO8E

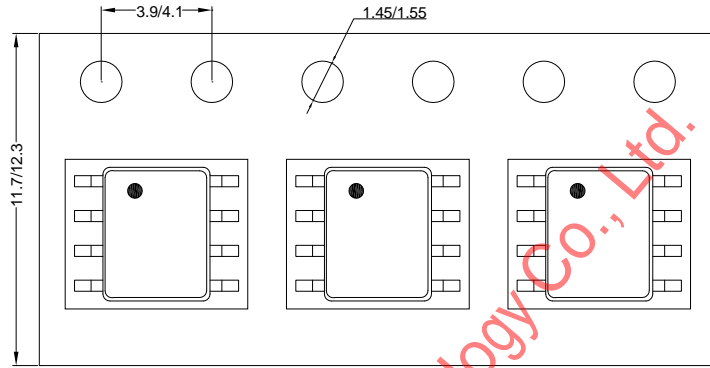

Feeding direction →

2. Carrier Tape & Reel specification for packages

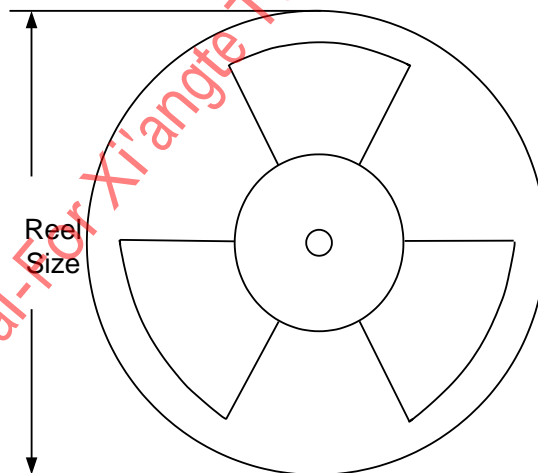

Package types	Tape width (mm)	Pocket pitch(mm)	Reel size (Inch)	Trailer length(mm)	Leader length (mm)	Qty per reel
SO8E	12	8	13"	400	400	2500

3. Others: NA