



AEC-Q200

This component was always RoHS compliant from the first date of manufacture.

- *Designed for TDMA IS-54 Receiver IF Applications*
- *Low Insertion Loss*
- *Excellent Selectivity*
- *Hermetic 13.3 X 6.5 mm Surface-mount Case*
- *Unbalanced Input and Output*
- *Complies with Directive 2002/95/EC (RoHS)*



PX1002

**86.85 MHz
SAW Filter**

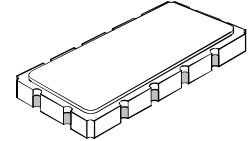

SM13365-12

Absolute Maximum Ratings

Rating	Value	Units
Maximum Incident Power in Passband	+10	dBm
Maximum DC Voltage Between any 2 terminals	30	VDC
Storage Temperature Range	-40 to +85	°C
Suitable for Lead-free Soldering - Maximum Soldering Profile	260 °C for 30 s	

Electrical Characteristics

Characteristic	Sym	Notes	Min	Typ	Max	Units
Nominal Center Frequency	f_C		86.850			MHz
Passband	Insertion Loss at f_C 3 dB Passband	IL		3	4.0	dB
		BW_3	± 12	± 25		kHz
	Amplitude Ripple over $f_C \pm 15$ kHz				1.0	dB _{P-P}
	Group Delay Variation over $f_C \pm 10$ kHz	GDV			6.0	μ s _{P-P}
Third-Order Intermod. for -20 dBm tones at $f_C \pm 60$ & 120 kHz					-95	dBm
Rejection	$f_C \pm 60$ kHz $f_C - 880$ kHz to $f_C - 940$ kHz Ultimate		11	16		dB
			65			
				65		
Operating Temperature Range	T_A		-20		+70	°C

Impedance Matching to 50 Ω unbalanced	External L-C
Case Style	SM13365-12 13.3 X 6.5 mm Nominal Footprint
Lid Symbolization (YY=year, WW=week, s=shift)	RFM PX1002 YYWWS
Standard 7" Reel Quantity	500 units
Standard 13" Reel Quantity	1000 units

Electrical Connections

Connection	Terminals
Port 1 Hot	2
Port 1 Gnd Return	3
Port 2 Hot	8
Port 2 Gnd Return	9
Case Ground	All Others



CAUTION: Electrostatic Sensitive Device. Observe precautions for handling.

NOTES:

1. The design, manufacturing process, and specifications of this device are subject to change.
2. US or International patents may apply.

SCHEMATIC, PX1002 (DEMO)

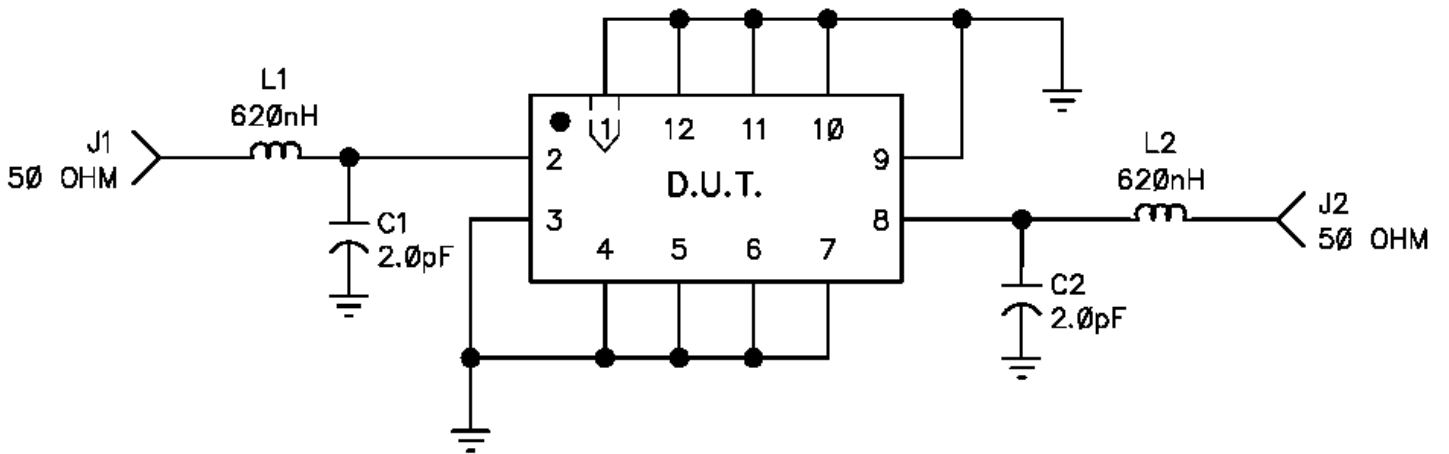

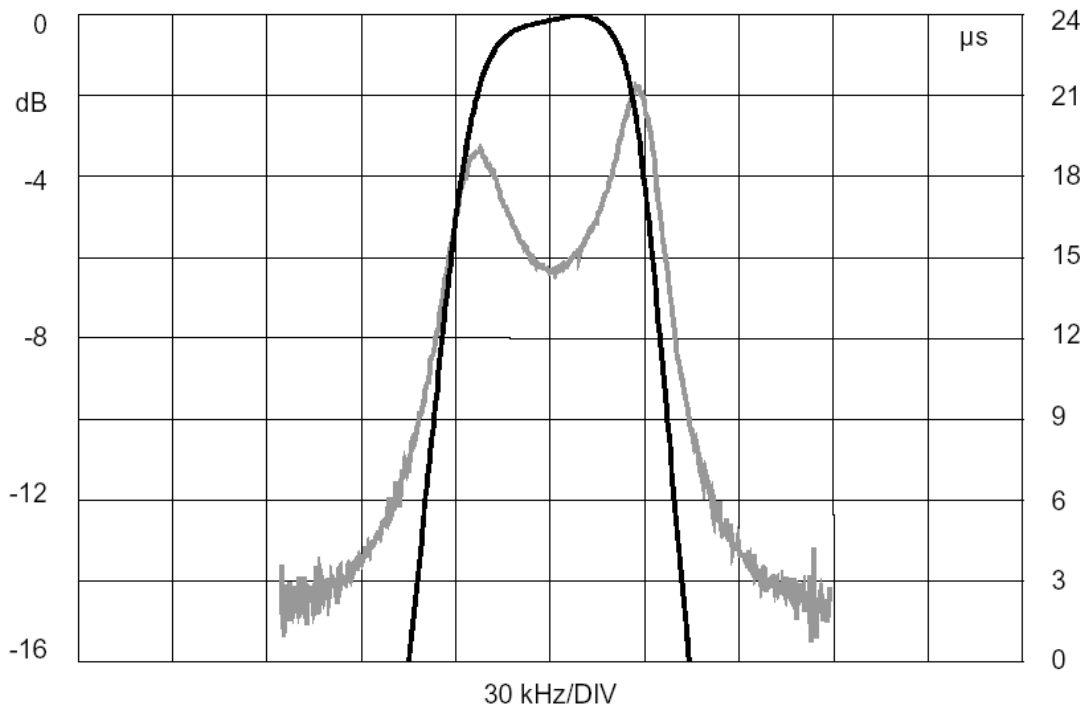
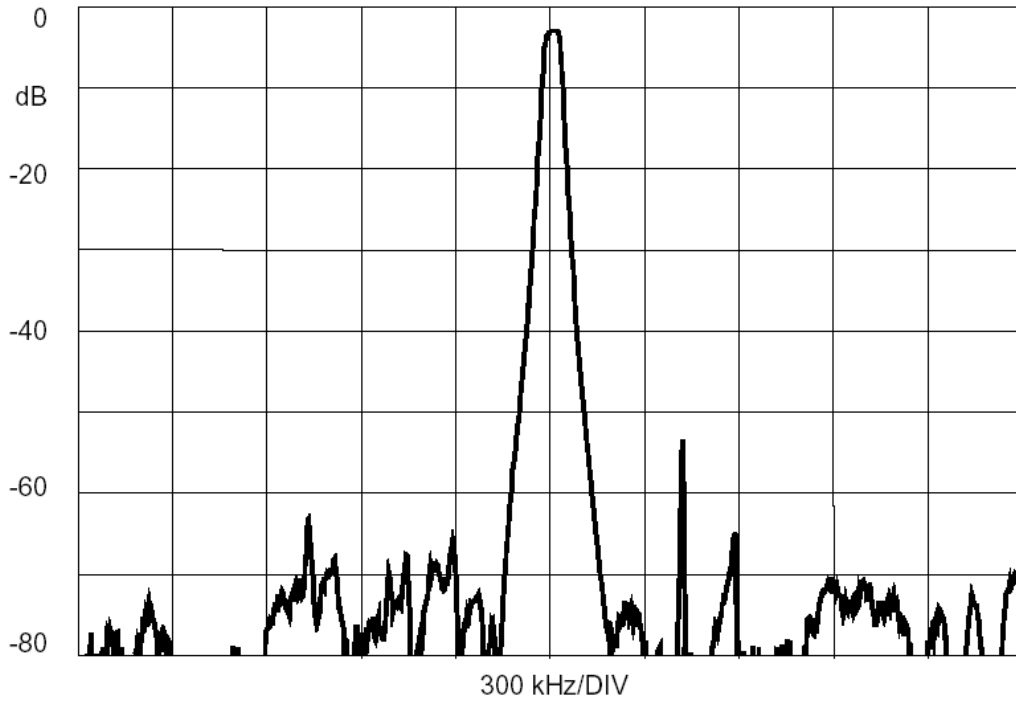

Tape and Reel Specifications

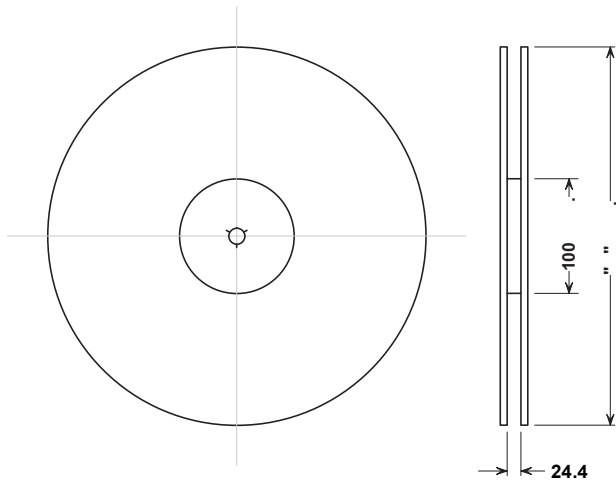

Tape and Reel Standard per ANSI/EIA-481

"B"		Quantity Per Reel
Inches	millimeters	
7	178	500
13	330	3000

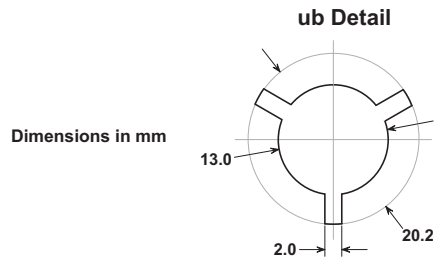

COMPONENT ORIENTATION and DIMENSIONS

Carrier Tape Dimensions	
Ao	7.0 mm
Bo	13.8 mm
Ko	2.0 mm
Pitch	12.0 mm
W	24.0 mm

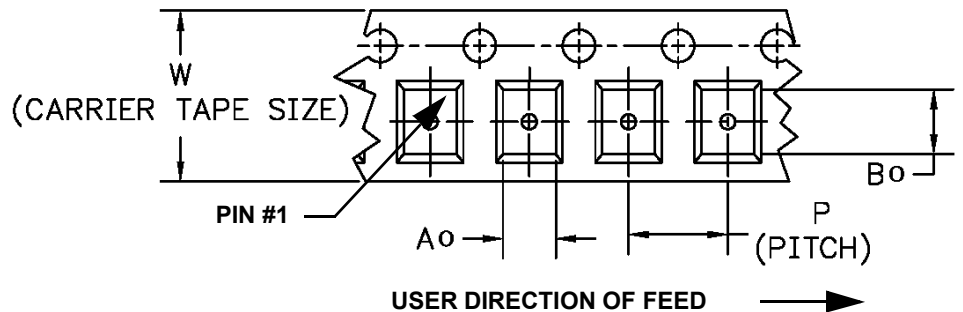
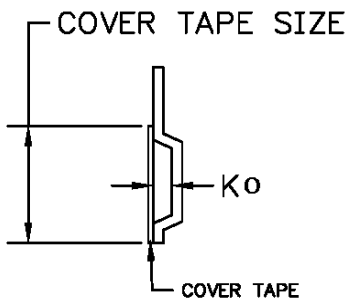

SM13365-12 Case

12-Terminal Ceramic Surface-Mount Case 13.3 x 6.5 mm Nominal Footprint

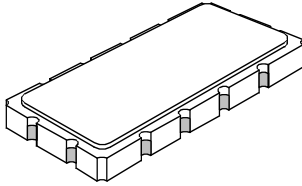

Case Dimensions						
Dimension	mm			Inches		
	Min	Nom	Max	Min	Nom	Max
A	13.08	13.31	13.60	0.515	0.524	0.535
B	6.27	6.50	6.80	0.247	0.256	0.268
C		1.91	2.00		0.075	0.079
D		1.50			0.059	
E		0.79			0.031	
H		1.0			0.039	
P		2.54			0.100	

Materials	
Solder Pad Plating	0.3 to 1.0 μm Gold over 1.27 to 8.89 μm Nickel
Lid Plating	2.0 to 3.0 μm Nickel
Body	Al_2O_3 Ceramic
	Pb Free

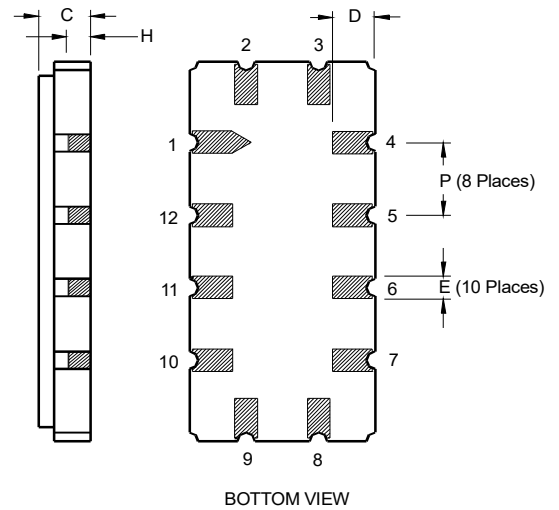
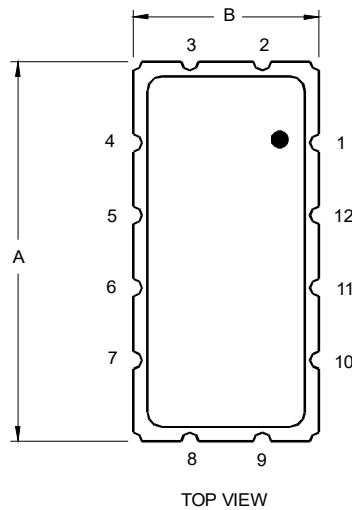
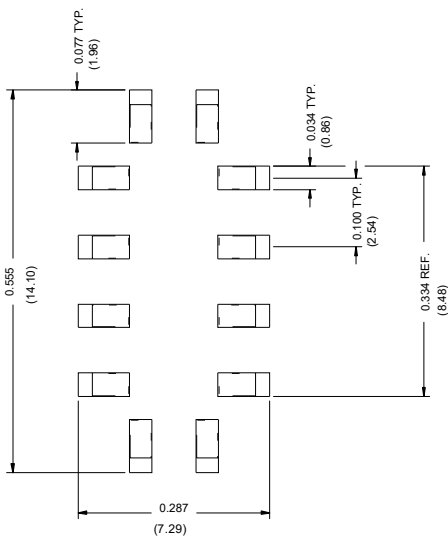

Recommended Reflow Profile

1. Preheating shall be fixed at 150~180°C for 60~90 seconds.
2. Ascending time to preheating temperature 150°C shall be 30 seconds min.
3. Heating shall be fixed at 220°C for 50~80 seconds and at 260°C +0/-5°C peak (10 seconds).
4. Time: 5 times maximum.

