

PX1004

**82.2 MHz
SAW Filter**

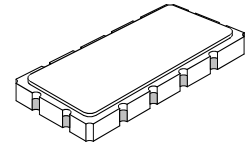

SM13365-12

- *Designed for TDMA IS-54 / CDPD IF Applications*
- *Low Insertion Loss*
- *Excellent Selectivity*
- *Hermetic 13.3 X 6.5 mm Surface-Mount Case*
- *Unbalanced Input and Output*
- *Complies with Directive 2002/95/EC (RoHS)*



Absolute Maximum Ratings

Rating	Value	Units
Maximum Incident Power in Passband	+10	dBm
Max. DC voltage between any 2 terminals	30	VDC
Storage Temperature Range	-40 to +85	°C
Suitable for lead-free soldering - Max Soldering Profile	260°C for 30 s	

Electrical Characteristics

Characteristic	Sym	Notes	Min	Typ	Max	Units
Nominal Center Frequency	f_C		82.200			MHz
Passband	Insertion Loss at f_C 3 dB Passband	IL		3	4.0	dB
		BW_3		± 15	± 25	kHz
	Amplitude Ripple over $f_C \pm 15$ kHz Group Delay Variation over $f_C \pm 10$ kHz	GDV			2.5	6.0
Third-Order Intermod. for -20 dBm tones at $f_C \pm 60$ & 120 kHz					-95	dBm
Rejection	$f_C \pm 60$ kHz $f_C - 880$ kHz to $f_C - 940$ kHz Ultimate		10	16		dB
			65	68		
				65		
Operating Temperature Range	T_A		-20		+70	°C

Impedance Matching to 50 Ω unbalanced	External L-C
Case Style	SM13365-12 13.3 X 6.5 mm Nominal Footprint
Lid Symbolization (YY=year, WW=week, S = Shift)	RFM, PX1004, YYWWS

Electrical Connections

Connection	Terminals
Port 1 Hot	2
Port 1 Gnd Return	3
Port 2 Hot	8
Port 2 Gnd Return	9
Case Ground	All Others



CAUTION: Electrostatic Sensitive Device. Observe precautions for handling.

NOTES:

1. The design, manufacturing process, and specifications of this device are subject to change.
2. US or International patents may apply.

SCHEMATIC, PX1004 (DEMO)

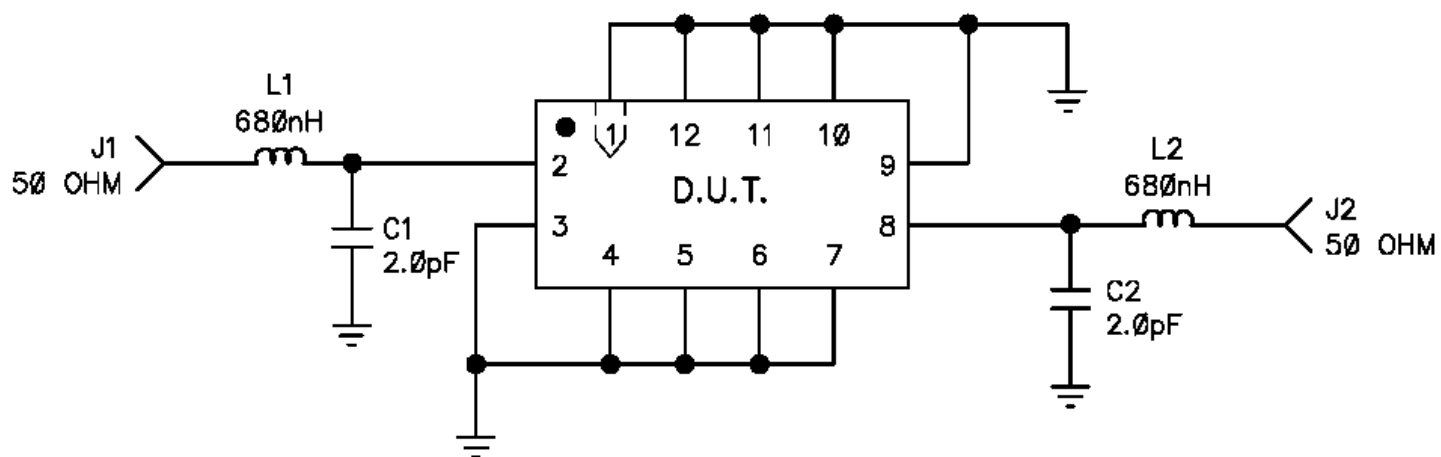

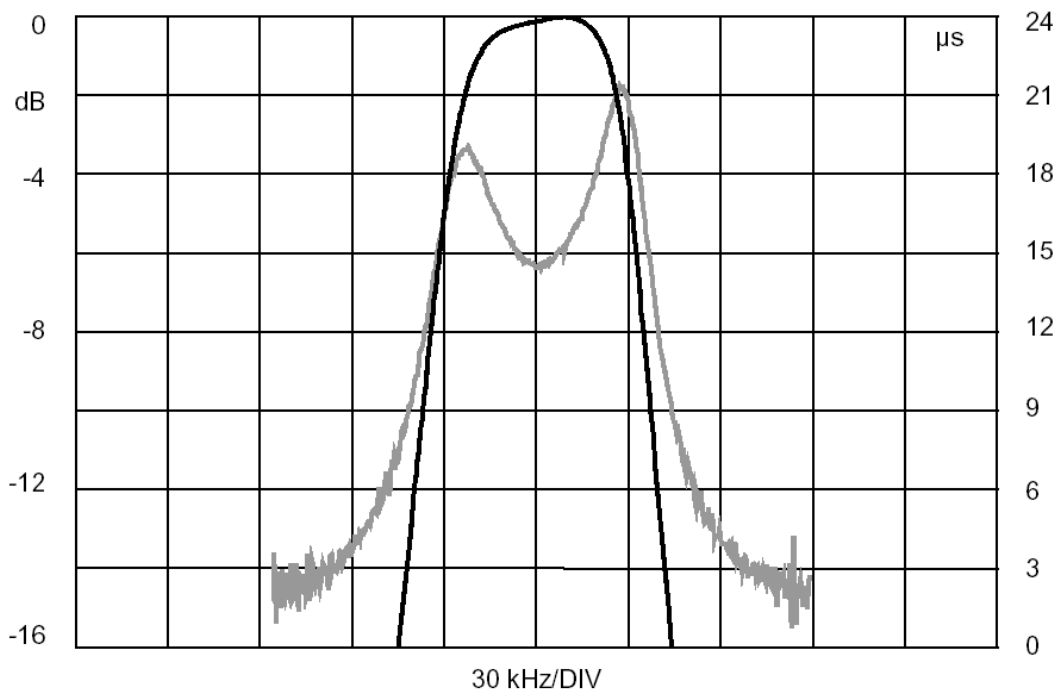
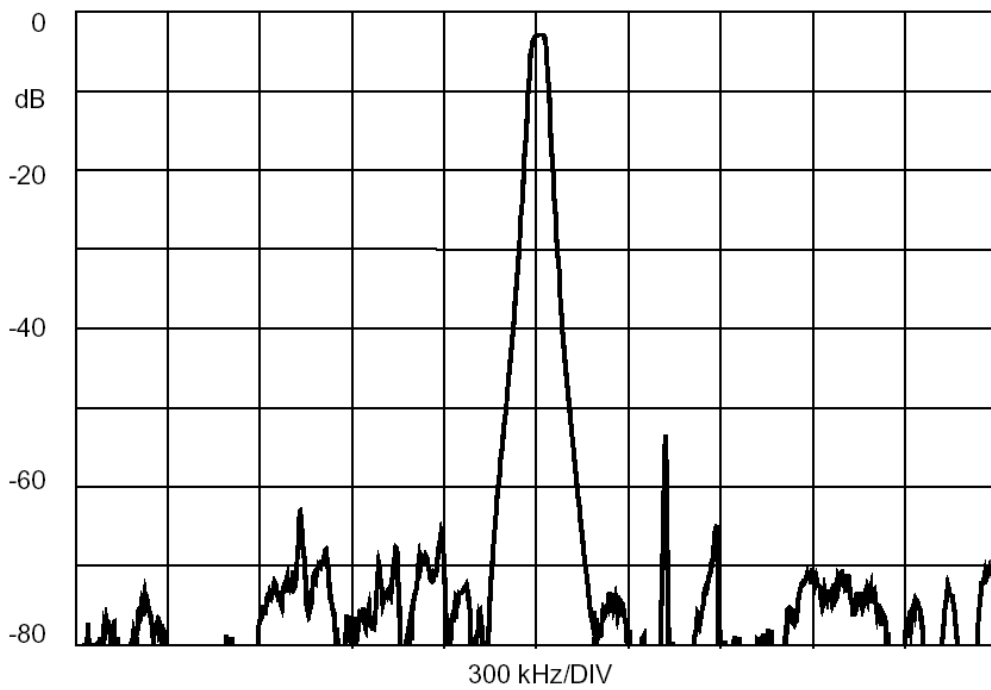

Tape and Reel Specifications

Tape and Reel Standard per ANSI/EIA-481

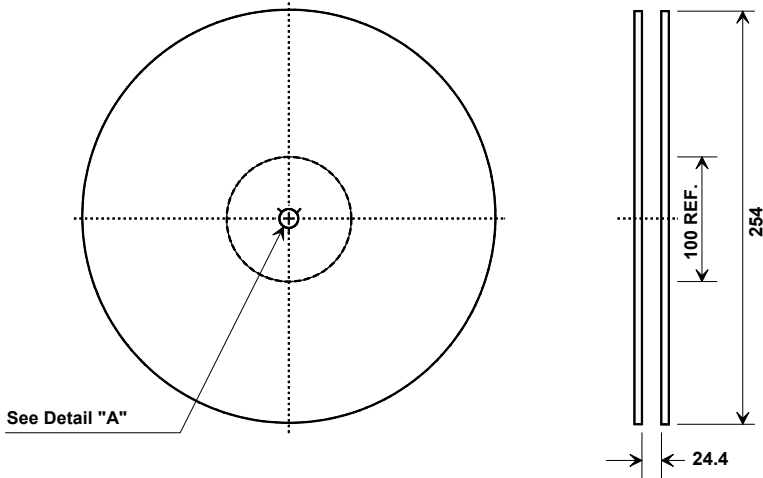

Quantity Per Reel	
100 Min	
1000 Max	

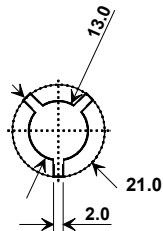

COMPONENT ORIENTATION and DIMENSIONS

Carrier Tape Dimensions	
Ao	7.0 mm
Bo	13.8 mm
Ko	2.0 mm
Pitch	12.0 mm
W	24.0 mm

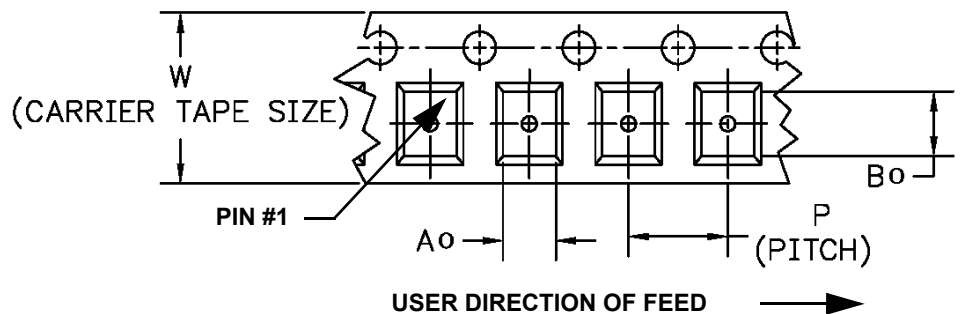
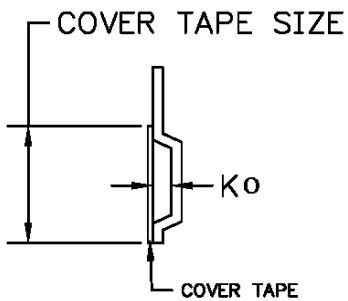

SM13365-12 Case

12-Terminal Ceramic Surface-Mount Case 13.3 x 6.5 mm Nominal Footprint

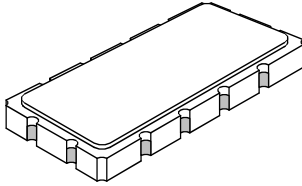

Case Dimensions						
Dimension	mm			Inches		
	Min	Nom	Max	Min	Nom	Max
A	13.08	13.31	13.60	0.515	0.524	0.535
B	6.27	6.50	6.80	0.247	0.256	0.268
C		1.91	2.00		0.075	0.079
D		1.50			0.059	
E		0.79			0.031	
H		1.0			0.039	
P		2.54			0.100	

Materials	
Solder Pad Termination	Au plating 30 - 60 ulnches (76.2-152 uM) over 80-200 ulnches (203-508 uM) Ni.
Lid	Fe-Ni-Co Alloy Electroless Nickel Plate (8-11% Phosphorus) 100-200 ulnches Thick
Body	Al ₂ O ₃ Ceramic
Pb Free	

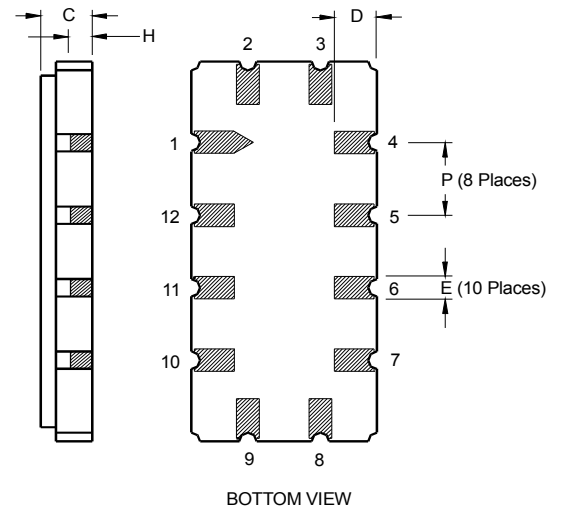
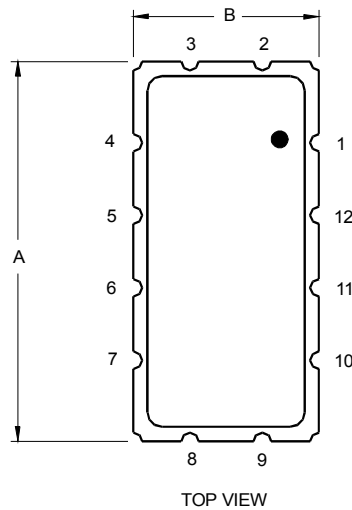
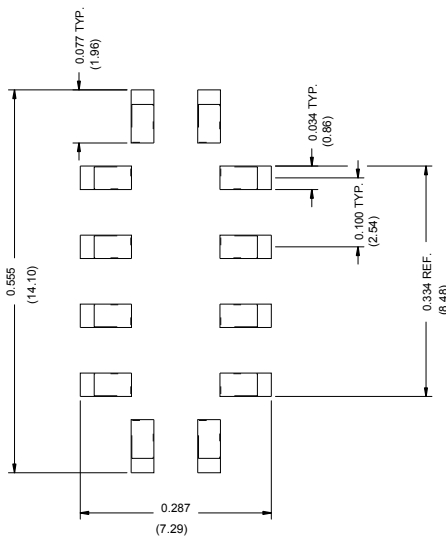

Recommended Reflow Profile

1. Preheating shall be fixed at 150~180°C for 60~90 seconds.
2. Ascending time to preheating temperature 150°C shall be 30 seconds min.
3. Heating shall be fixed at 220°C for 50~80 seconds and at 260°C+0/-5°C peak (10 seconds).
4. Time: 5 times maximum.

