

Current Transducer LT 58-S7/SP1

For the electronic measurement of currents: DC, AC, pulsed..., with galvanic isolation between the primary circuit and the secondary circuit.

$$I_{PN} = 50 \text{ A}$$

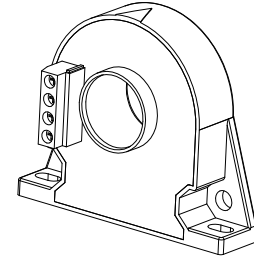

Electrical data

I_{PN}	Primary nominal current rms	50	A	
I_{PM}	Primary current, measuring range	0 .. ± 70	A	
R_M	Measuring resistance	$R_{M \min}$ $R_{M \max}$		
				with $\pm 12 \text{ V}$
		@ $\pm 70 \text{ A}_{\max}$	0 70	Ω
	with $\pm 15 \text{ V}$	@ $\pm 50 \text{ A}_{\max}$	0 200	Ω
	@ $\pm 70 \text{ A}_{\max}$	0 110	Ω	
I_{SN}	Secondary nominal current rms	50	mA	
K_N	Conversion ratio	1 : 1000		
V_C	Supply voltage ($\pm 5 \%$)	$\pm 12 \dots 15$	V	
I_C	Current consumption	20 (@ $\pm 15 \text{ V}$) + I_S	mA	

Accuracy - Dynamic performance data

X_G	Overall accuracy @ I_{PN} , $T_A = 25^\circ\text{C}$	± 0.8	%
\mathcal{E}_L	Linearity error		%
		Typ	Max
I_{OE}	Electrical offset current @ $I_p = 0$, $T_A = 25^\circ\text{C}$		± 0.20 mA
I_{OM}	Magnetic offset current ¹⁾ @ $I_p = 0$, and specified R_M , after an overload of $3 \times I_{PN}$		± 0.10 mA
I_{OT}	Temperature variation of I_O - $10^\circ\text{C} \dots +70^\circ\text{C}$	± 0.35 ± 0.64	mA
t_{ra}	Reaction time to 10 % of I_{PN} step	< 500	ns
t_r	Response time ²⁾ to 90 % of I_{PN} step	< 1	μs
di/dt	di/dt accurately followed	> 100	A/ μs
BW	Frequency bandwidth (-3 dB)	DC .. 100	kHz

General data

T_A	Ambient operating temperature	- 10 .. + 70	$^\circ\text{C}$
T_S	Ambient storage temperature	- 25 .. + 80	$^\circ\text{C}$
R_S	Secondary coil resistance @ $T_A = 70^\circ\text{C}$	11	Ω
m	Mass	68	g
	Standard	EN 50178: 1997	

Notes: ¹⁾ Result of the coercive field of the magnetic circuit

²⁾ With a di/dt of 100 A/ μs .

Features

- Closed loop (compensated) current transducer using the Hall effect
- Isolated plastic case recognized according to UL 94-V0.

Special feature

- Secondary connection on JTB450-00.

Advantages

- Excellent accuracy
- Very good linearity
- Low temperature drift
- Optimized response time
- Wide frequency bandwidth
- No insertion losses
- High immunity to external interference
- Current overload capability.

Applications

- AC variable speed drives and servo motor drives
- Static converters for DC motor drives
- Battery supplied applications
- Uninterruptible Power Supplies (UPS)
- Switched Mode Power Supplies (SMPS)
- Power supplies for welding applications.

Application Domain

- Industrial.

Current Transducer LT 58-S7/SP1

Isolation characteristics

V_d	Rms voltage for AC insulation test ¹⁾ , 50 Hz, 1 min	3.52	kV
\hat{V}_w	Impulse withstand voltage 1.2/50 μ s	6.5	kV
		Min	
dCp	Creepage distance ²⁾	10	mm
dCI	Clearance ²⁾	6	mm
CTI	Comparative Tracking Index (group IIIa)	275	

Notes: ¹⁾ Between primary and secondary

²⁾ On housing.

Applications examples

According to EN 50178 and IEC 61010-1 standards and following conditions:

- Over voltage category OV 3
- Pollution degree PD2
- Non-uniform field

	EN 50178	IEC 61010-1
dCp, dCI, \hat{V}_w	Rated insulation voltage	Nominal voltage
Basic insulation	600 V	600 V
Reinforced insulation	300 V	300 V

Safety



This transducer must be used in electric/electronic equipment with respect to applicable standards and safety requirements in accordance with the manufacturer's operating instructions.



Caution, risk of electrical shock

When operating the transducer, certain parts of the module can carry hazardous voltage (eg. primary busbar, power supply).

Ignoring this warning can lead to injury and/or cause serious damage.

This transducer is a build-in device, whose conducting parts must be inaccessible after installation.

A protective housing or additional shield could be used.

Main supply must be able to be disconnected.

Dimensions LT 58-S7/SP1 (in mm)

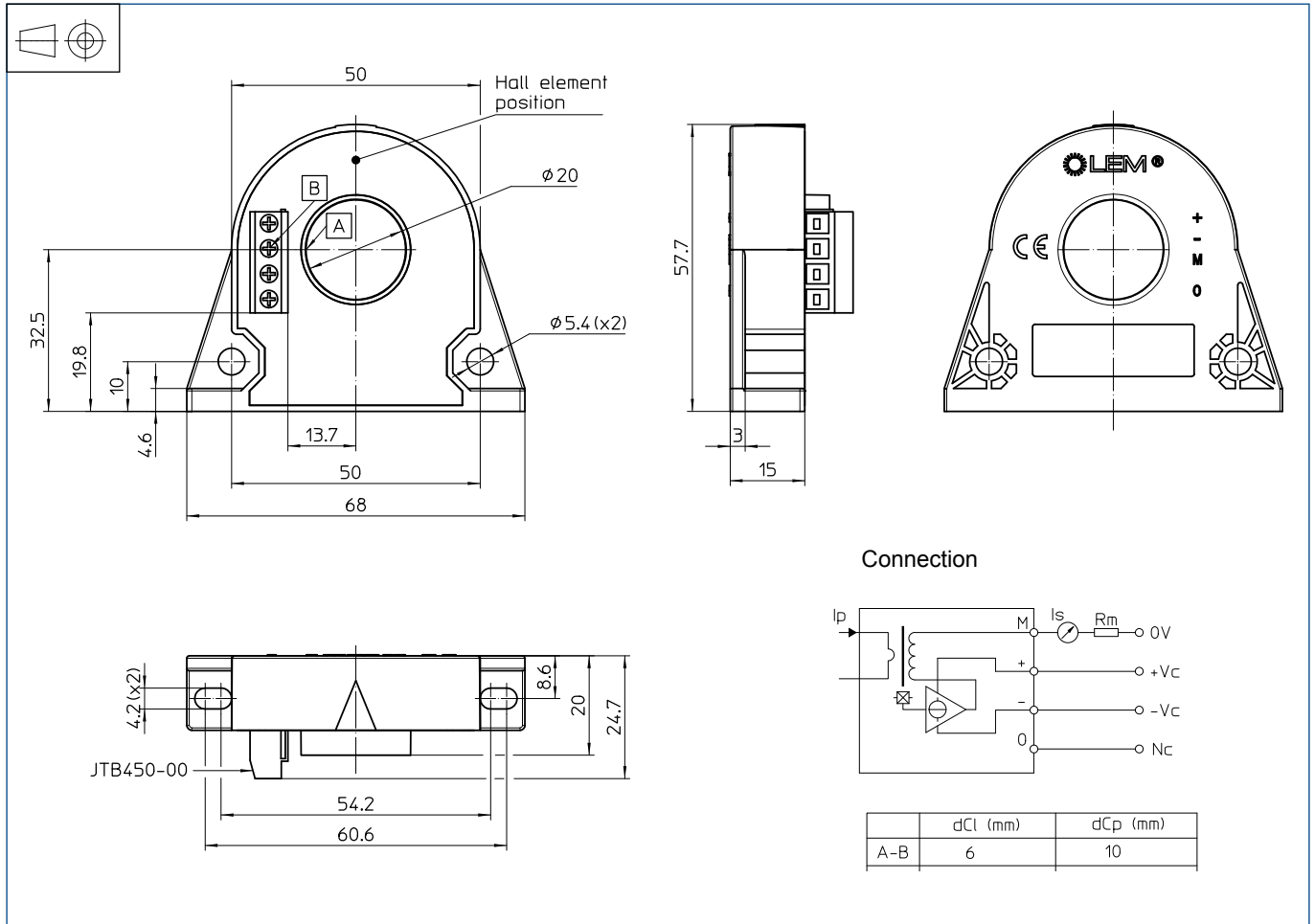

Mechanical characteristics

- General tolerance ± 0.5 mm
- Transducer fastening
 - 2 holes $\phi 5.4$ mm
 - 2 M5 steel screws
- Recommended fastening torque 1.5 Nm (± 10 %)
- Or
 - 2 notches 4.2 mm
 - 2 M4 steel screws
- Recommended fastening torque 0.75 Nm (± 10 %)
- Primary through-hole $\phi 20$ mm
- Connection of secondary Socket JTB450-00 (JITE, Shenzhen)

Remarks

- I_s is positive when I_p flows in the direction of the arrow.
- Temperature of the primary conductor should not exceed 100°C .
- Dynamic performances (di/dt and response time) are best with a single bar completely filling the primary hole.