

SPECIFICATIONS

CONTACT RATING: Dependent upon contact material See Page 125.

MECHANICAL LIFE: 50,000 make-and-break cycles.

CONTACT RESISTANCE: 20 mΩ max. initial @ 2-4VDC
100mA for both silver and gold plated contacts.

INSULATION RESISTANCE: 1,000 MΩ min.

DIELECTRIC STRENGTH: 1,000 Vrms min.@sea level.

OPERATING TEMPERATURE: -30°C to 85°C.

MATERIALS

CASE & BUSHING: Glass filled nylon 6/6, flame retardand, heat stabilized (UL94V-0).

PLUNGER: Thermoplastic Polyester (UL 94V-0), with intenal O-ring seal.

SWITCH SUPPORT: Brass or steel electrotin plated.

CONTACT: Copper alloy,with silver or gold plated.
(See Page 125)

IP 67
ACCORDING TO
EN 60529:1991+A1:2001
IEC 60529:2001

UL US
E 187490

RoHS
compliant

Pb
lead-free

HOW TO ORDER

MODEL NO. ACTUATOR BUSHIBG TERMINATIONS TERMINAL SEAL RoHS CAPS CAP COLOR
SOLDERING See below

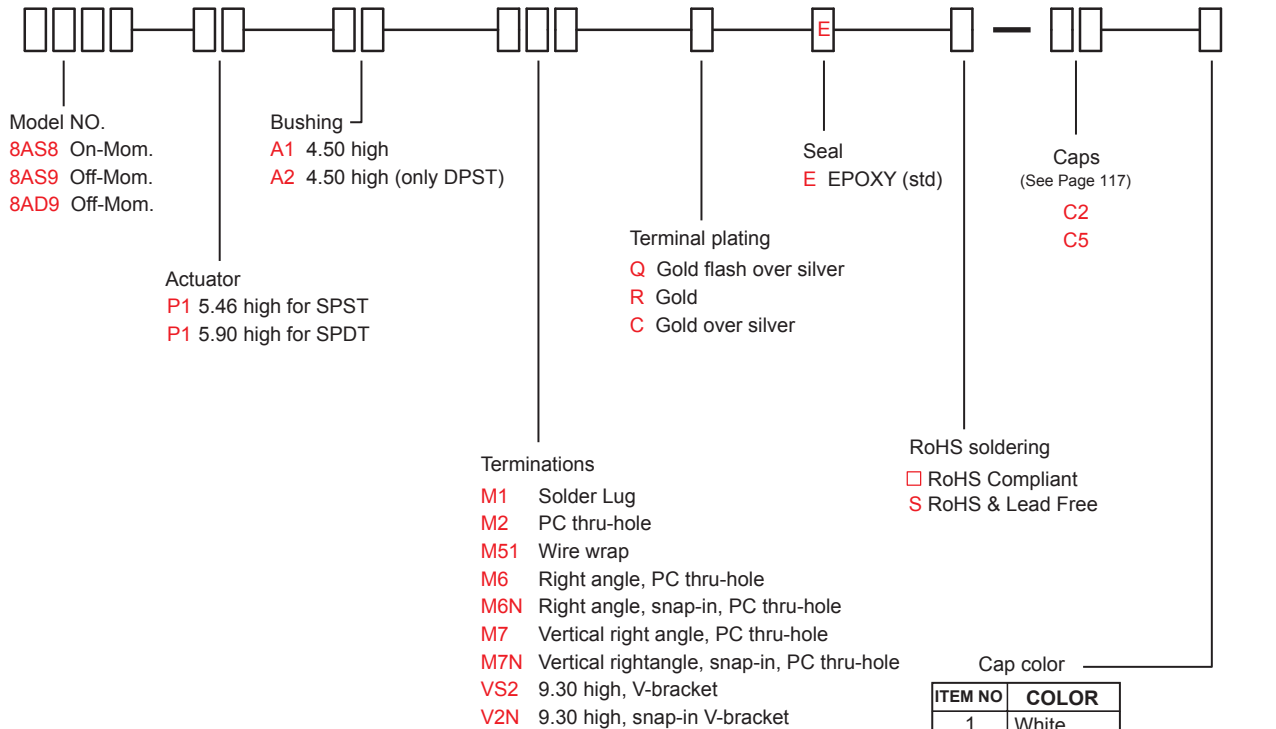

* Besides standard color, other colors need to check stocks available.



8A Series

Sealed Sub-Miniature Pushbutton Switches

SWITCH FUNCTION

NO. POLES	UL/CSA MODEL NO.	MODEL NO.	SWITCH FUNCTION		CONNECTED TERMINALS / SCHEMATIC	
			POS.1	POS.2	POS.1	POS.2
SP	Q28A18	8AS8	ON	MOM	2-1 NC 1 • 2 (COMM) • 3 NO	2-3 NC 1 • 2 (COMM) • 3 NO
	Q28A19	8AS9	OFF	MOM	OPEN	1-3
DP	Q28A29	8AD9	OFF	MOM	OPEN	1-3,4-6

MOM=MOMENTARY

POLE OPTIONS

8A Pushbutton Switches

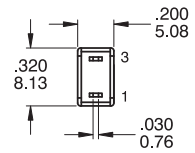
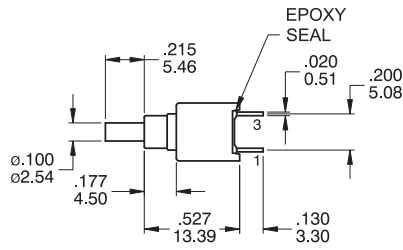
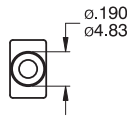

SPST

Part No. Shown : 8AS9P1A1M2RE

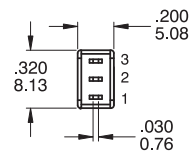
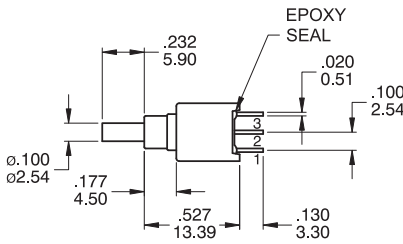
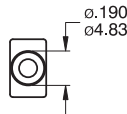

SPDT

Part No. Shown : 8AS8P1A1M2RE

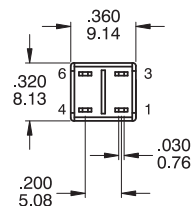
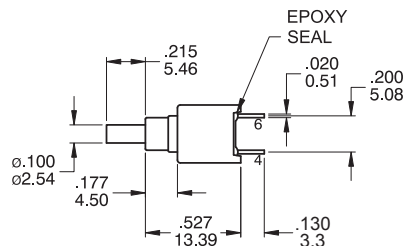
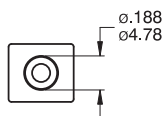

DPST

Part No. Shown : 8AD9P1A2M2RE

TERMINATION OPTIONS

M1 Solder lug

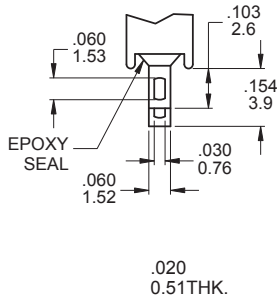

M2 PC Thru-hole

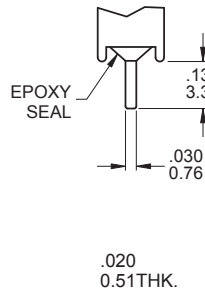

M51 Wire Wrap

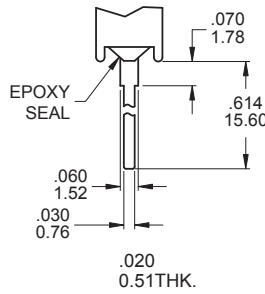

OTHER TERMINATION OPTIONS

- M6** Right angle P.C. Mount
- M6N** Right angle P.C. Mount With snap-in bracket
- M7** Right angle P.C. Mount
- M7N** Right angle P.C. Mount With snap-in bracket
- VS2** Vertical bracket P.C. Mount
- V2N** Vertical bracket P.C. Mount With snap-in bracket

M6

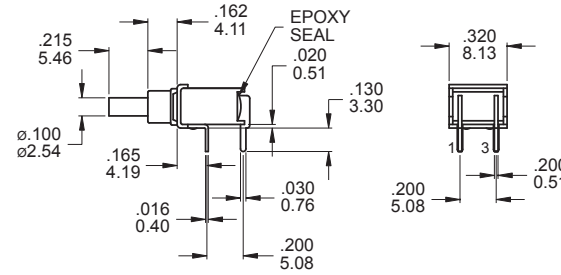
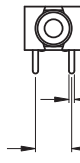

P.C. MOUNTING

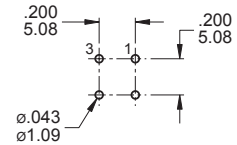

SPST

Part No. Shown : 8AS9P1A1M6RE

M6

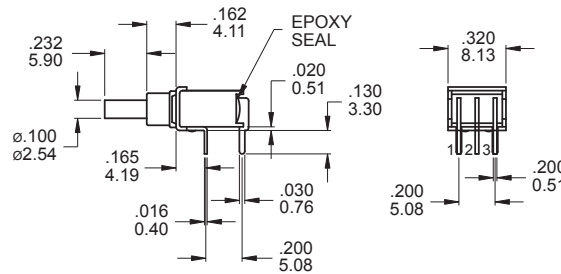
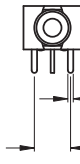

P.C. MOUNTING

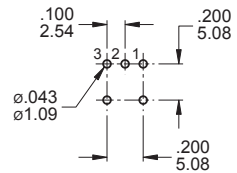

SPDT

Part No. Shown : 8AS8P1A1M6RE

M6

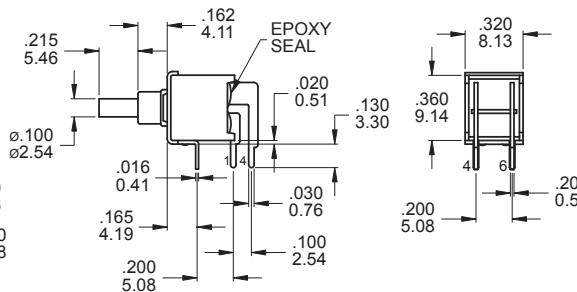
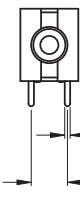

P.C. MOUNTING

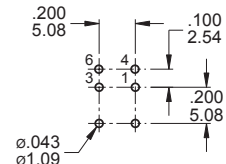

DPST

Part No. Shown : 8AD9P1A2M6RE



8A Series

Sealed Sub-Miniature Pushbutton Switches

M7

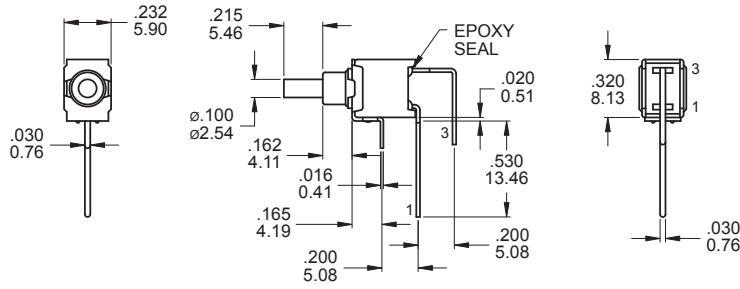

P.C. MOUNTING

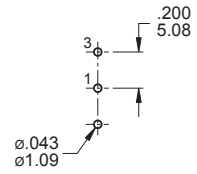

Part No. Shown : 8AS9P1A1M7RE

SPST



M7

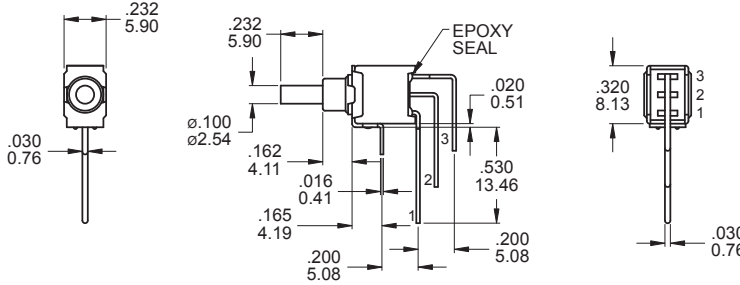

P.C. MOUNTING

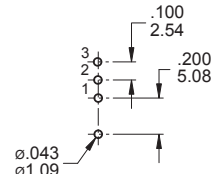

Part No. Shown : 8AS8P1A1M7RE

SPDT

8A
Pushbutton Switches

M7

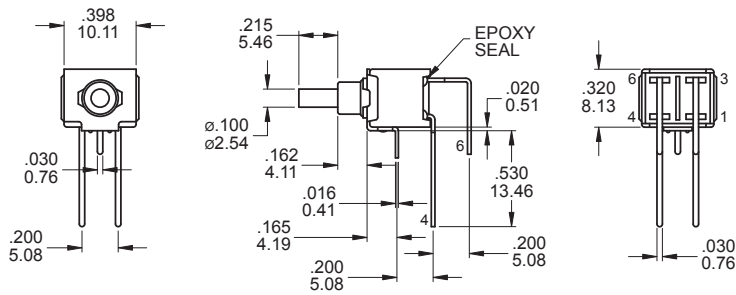

P.C. MOUNTING

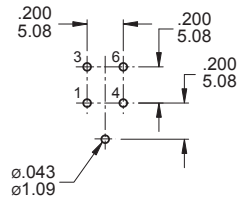

Part No. Shown : 8AD9P1A2M7RE

DPST

VS2

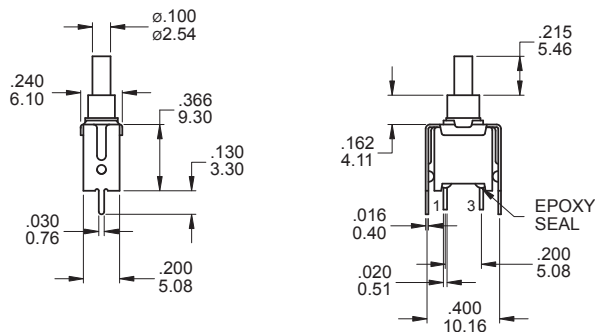

P.C. MOUNTING

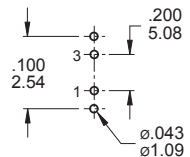

Part No. Shown : 8AS9P1A1VS2RE

SPST

VS2

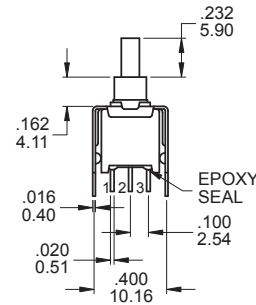
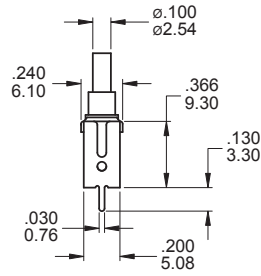

P.C. MOUNTING

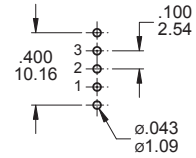

SPDT

Part No. Shown : 8AS8P1A1VS2RE

VS2

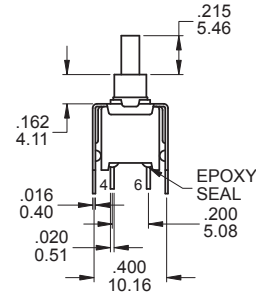
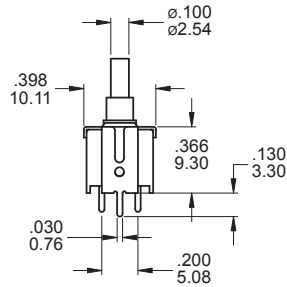

P.C. MOUNTING

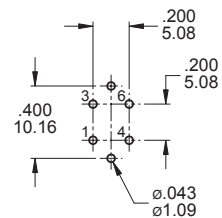

DPST

Part No. Shown : 8AD9P1A2VS2RE

CONTACT MATERIAL OPTIONS

	CONTACT PLATING	TERMINAL PLATING	RATINGS
Q	Silver	Q = Gold flash over silver	3 Amps with resistant load @ 120VAC or 28VDC 1 Amps with resistant load @ 250VAC
C	Gold over Silver	C = Gold over silver	
R	Gold	R = Gold	0.4 Volt - Amps (VA) max. @ 20V max. (AC or DC)

SOLDERING PROCESSES

MANUAL SOLDERING: Use soldering iron of 30 watts, controlled at 350°C approximately 5 seconds while applying solder.

WAVE SOLDERING: Recommended Soldering Temperature: 270 ± 5°C
Duration of Solder Immersion: Max 5 sec. (PCB is 1.6mm in thickness)

