

X2-MRA Series

Rocker Switches



SPECIFICATIONS

Electrical rating : 3A 250VAC & 3A 125VAC

Contact resistance: < 20mΩ(initial)

Insulation resistance: > 1000MΩ(500VDC between open contacts)

Dielectric strength: > 1500V 1 minute

Mechanical life: > 30000 cycles

Electrical life: > 10000 cycles

Temperature rise at the terminal: Max.30°C

Solder ability of terminal: Max350°C, 3S(no pressure may be placed in the terminals when soldering by hand)

Any Cd Pb Hg etc and it's compounds is not include in this product

Ambient temperature: 10T85/55

Ambient humidity: Max.85%

Degree of protection: IP20

Applicability for appliance of class: class II

Proof tracking resistance index(PTI): 175

Degree of pollution: normal

MATERIALS

Housing: PA66

Rocker: PA66

Contacts: Silver alloy

Terminal: Brass silver plated

Spring: SWC

Movable arm: Brass silver plated



HOW TO ORDER

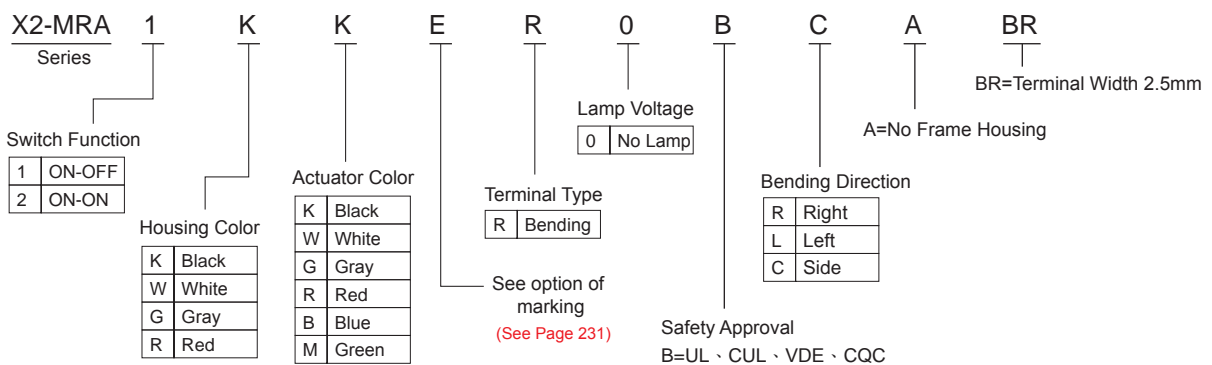
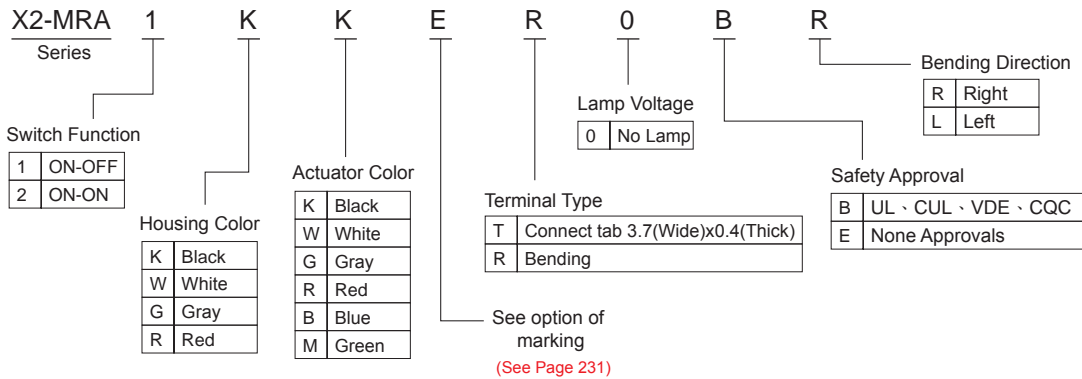

OPTIONS OF SWITCH FUNCTION

Item NO	POLES & THROWS	Rocker position		
		Left	Center	Right
X2-MRA1	SPST	ON	None	OFF
X2-MRA2	SPDT	ON	None	ON

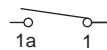

CIRCUIT SPST

POLE FUNCTION	OPTIONS OF FUNCTION		
	A	—	B
SPST	1-1a	—	OFF

Part No. Shown :
MRA1KKETB

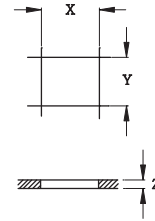
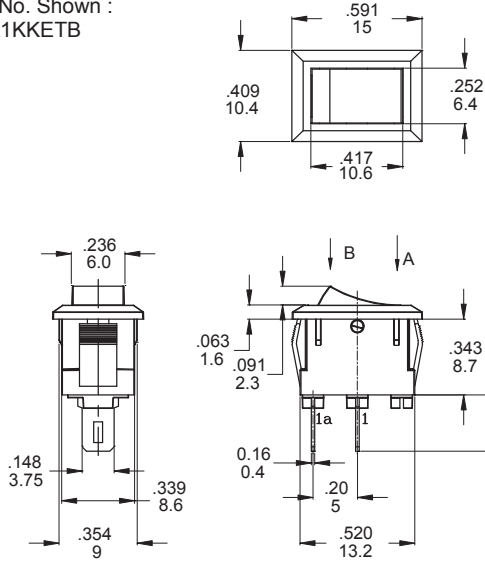

PANEL OUT-CUT		
Z	Y	X
0.7~1.25 [.028~.049]	9.1~9.2 [.358~.362]	13.6~13.8 [.535~.543]
1.25~2.0 [.049~.079]	9.1~9.2 [.358~.362]	13.8~14.0 [.543~.551]
2.0~3.0 [.079~.118]	9.1~9.2 [.358~.362]	14.0~14.1 [.551~.555]

* We keep the right to alter the dimension without notice.

Part No. Shown :
MRA1KKFR0BL

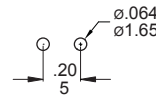
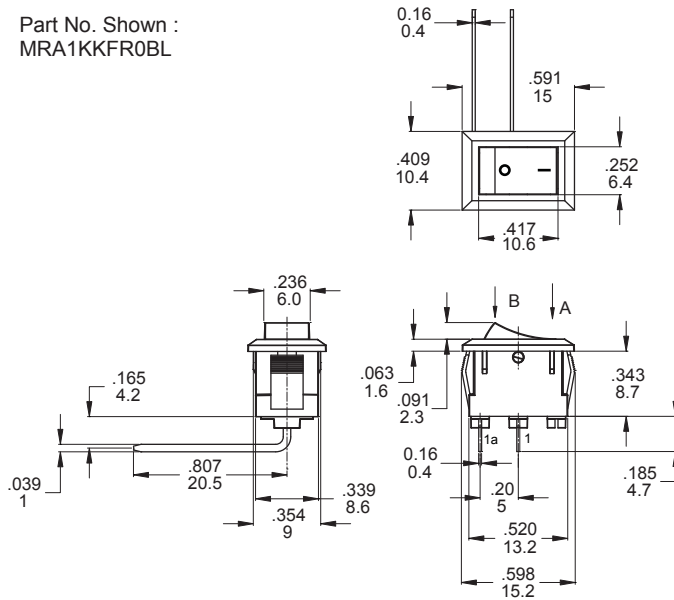

PC MOUNTING

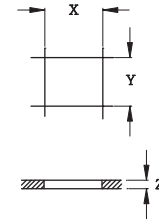

PANEL OUT-CUT		
Z	Y	X
0.7~1.25 [.028~.049]	9.1~9.2 [.358~.362]	13.6~13.8 [.535~.543]
1.25~2.0 [.049~.079]	9.1~9.2 [.358~.362]	13.8~14.0 [.543~.551]
2.0~3.0 [.079~.118]	9.1~9.2 [.358~.362]	14.0~14.1 [.551~.555]

* We keep the right to alter the dimension without notice.

Part No. Shown :
MRA1KKFR0BCA-BR

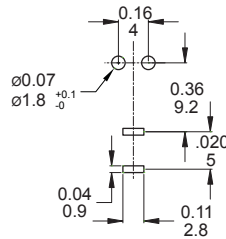
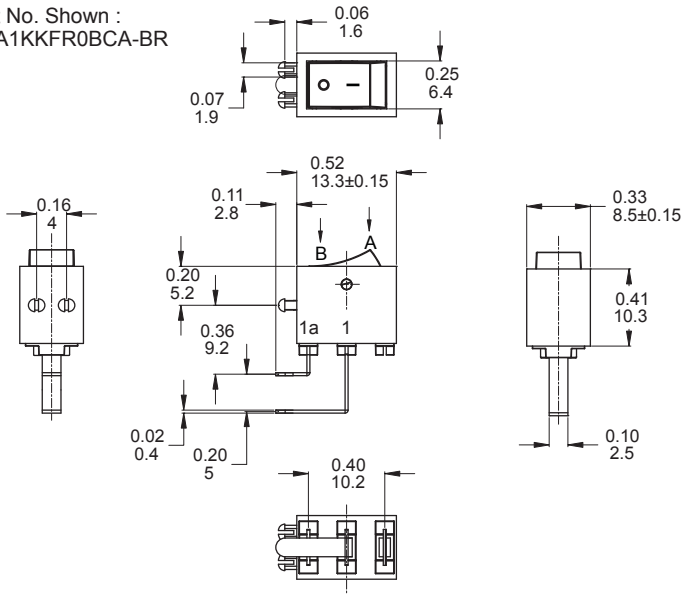

P.C MOUNTING

PANEL OUT-CUT	
Y	X
8.7~8.9 [.338~.354]	13.5~13.7 [.528~.543]

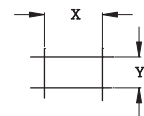

* We keep the right to alter the dimension without notice.