

SPECIFICATIONS

CONTACT RATING: Dependent upon contact material See Page 69.

MECHANICAL LIFE: 30,000 make-and-break cycles.

CONTACT RESISTANCE: 20 mΩ max. initial @ 2-4VDC
100mA for both silver and gold plated contacts.

INSULATION RESISTANCE: 1,000 MΩ min.

DIELECTRIC STRENGTH: 1,000 Vrms min. @sea level.

OPERATING TEMPERATURE: -30°C to 85°C.

MATERIALS

CASE: Diallyl phthalate (DAP) (UL94v-0).

ACTUATOR: Nylon, black std.

BUSHING: Brass or Zinc, nickel plated.

HOUSING: Stainless Steel.

SWITCH SUPPORT: SUS or Brass, tin plated.

TERMINAL/CONTACT: Copper alloy or Brass, with silver or gold plated. (See Page 69)



4M
Rocker Switches

HOW TO ORDER

MODEL NO. ACTUATOR ACTUATOR COLOR ACTUATOR MARKING TERMINATIONS TERMINAL PLATING SEAL RoHS SOLDERING

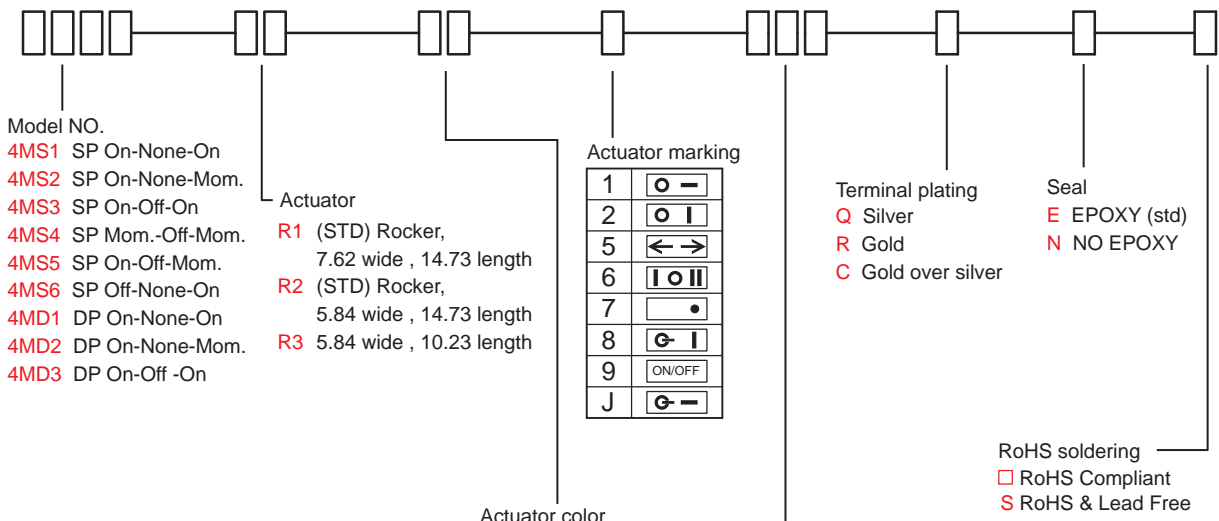

Actuator color

ITEM NO	COLOR
01	White
02	Black (Std)
03	Red
04	Orange
05	Yellow
06	Green
07	Blue
08	Brown
09	Gray

* Besides standard color, other colors need to check stocks available.

Terminations

M1	Solder Lug
M2	PC thru-hole
M5	wire wrap
M6	Right angle, PC thru-hole
M6N	Right angle, snap-in, PC thru-hole
M7	Vertical right angle, PC thru-hole
M7N	Vertical right angle, snap-in, PC thru-hole
VS2	8.94 high, V-bracket
V2N	8.94 high, snap-in V-bracket
VS3	8.94 high, V-bracket
V3N	8.94 high, snap-in V-bracket

4M Series

Sub-Miniature Rocker Switches

SWITCH FUNCTION

NO. POLES	UL/CSA MODEL NO.	MODEL NO.	SWITCH FUNCTION			CONNECTED TERMINALS / SCHEMATIC		
			POS.1	POS.2	POS.3	POS.1	POS.2	POS.3
SP	Q2411	4MS1	ON	NONE	ON	2-3	N/A	2-1
	Q2412	4MS2	ON	NONE	MOM			
	Q2413	4MS3	ON	OFF	ON		OPEN	
	Q2414	4MS4	MOM	OFF	MOM			
	Q2415	4MS5	ON	OFF	MOM	OPEN	N/A	3-1
	Q2416	4MS6	OFF	NONE	ON			
DP	Q2421	4MD1	ON	NONE	ON	2-3,5-6	N/A	2-1,5-4
	Q2422	4MD2	ON	NONE	MOM			
	Q2423	4MD3	ON	OFF	ON		OPEN	

MOM=MOMENTARY

POLE OPTIONS

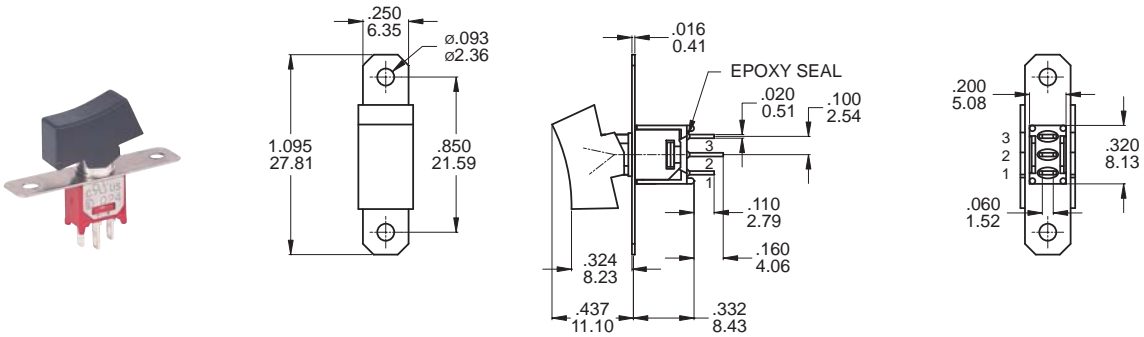

SPDT

Part No. Shown : 4MS1R102M1QE

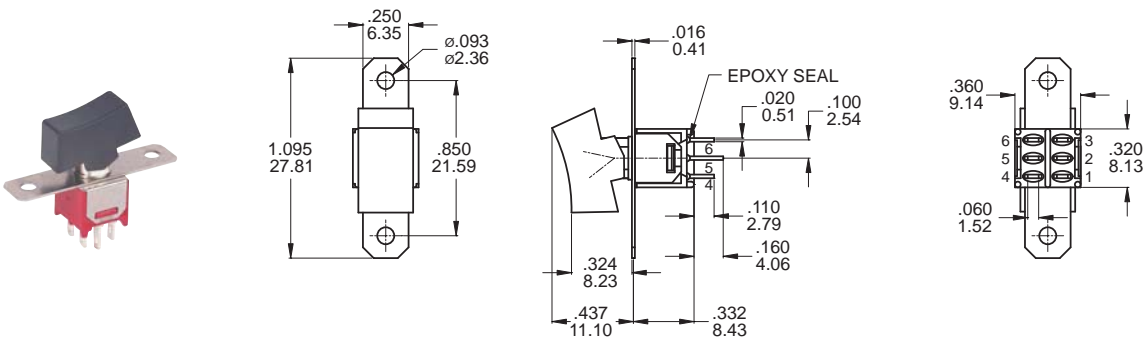

DPDT

Part No. Shown : 4MD1R102M1QE



4M
Rocker Switches

ACTUATOR OPTIONS - PANEL MOUNT

R1

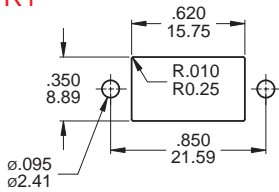

PANEL MOUNTING-R1

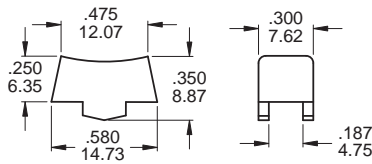

R2

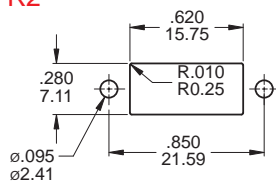

PANEL MOUNTING-R2

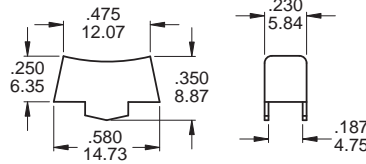

R3

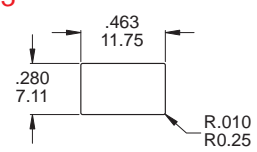

PANEL MOUNTING-R3

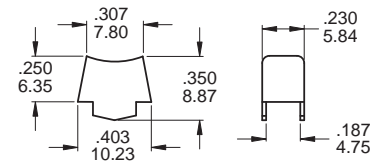

TERMINATION OPTIONS

M1 Solder lug

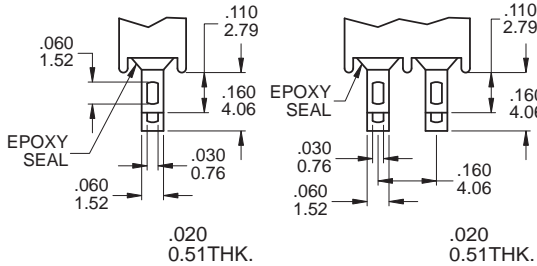

Double Pole

M2 PC Thru-hole

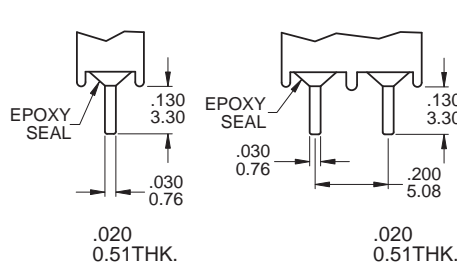

Double Pole

M5 Wire Wrap

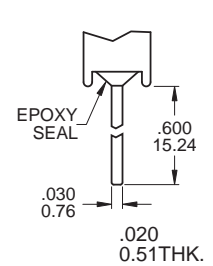

M6

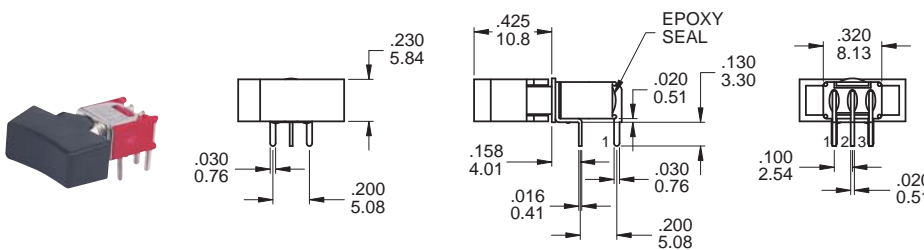

P.C. MOUNTING

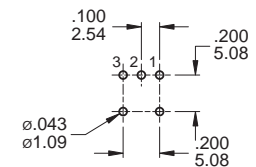

SPDT

Part No. Shown : 4MS1R202M6QE

M6

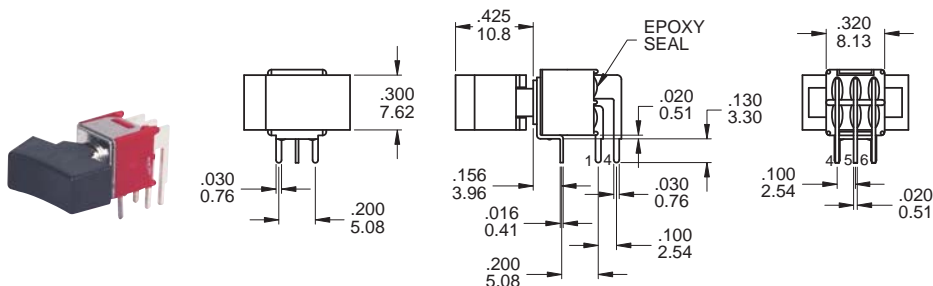

P.C. MOUNTING

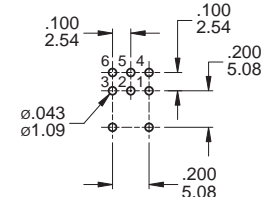

DPDT

Part No. Shown : 4MD1R102M6QE



4M Series

Sub-Miniature Rocker Switches



4M
Rocker Switches

M7

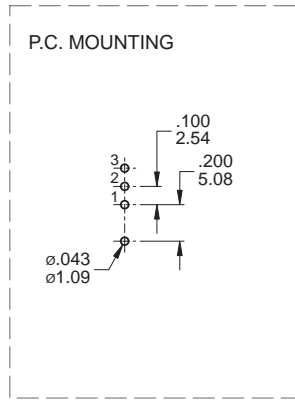
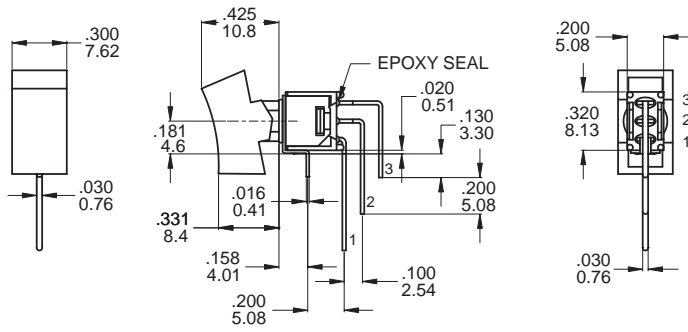

SPDT

Part No. Shown : 4MS1R102M7QE

M7

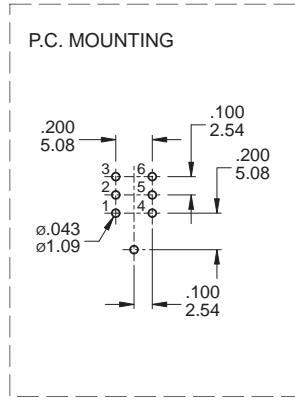
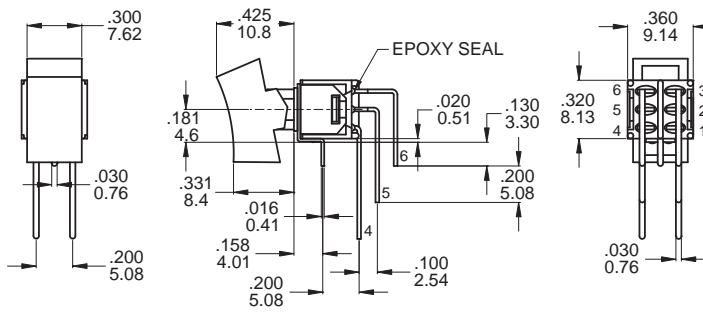

DPDT

Part No. Shown : 4MD1R102M7QE

VS2 - VS3

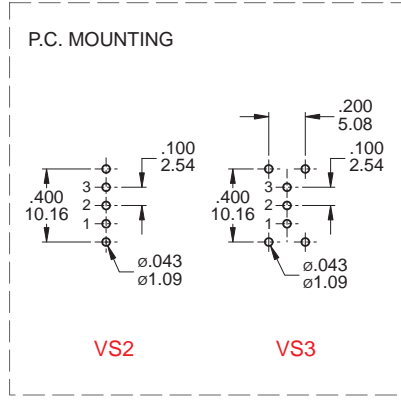
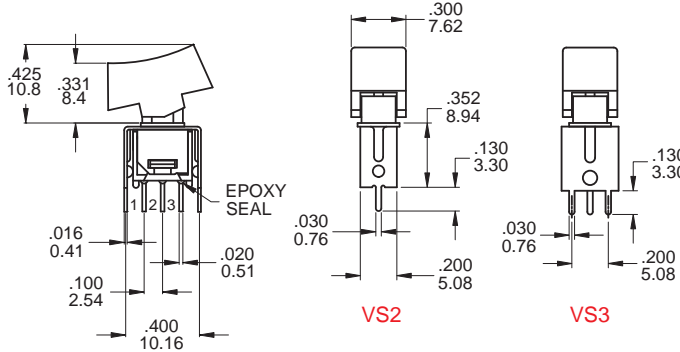

SPDT

Part No. Shown : 4MS1R102VS2QE

VS2 - VS3

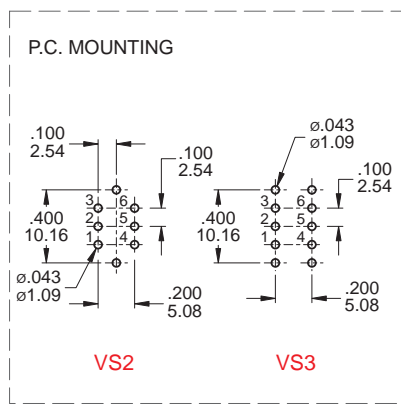
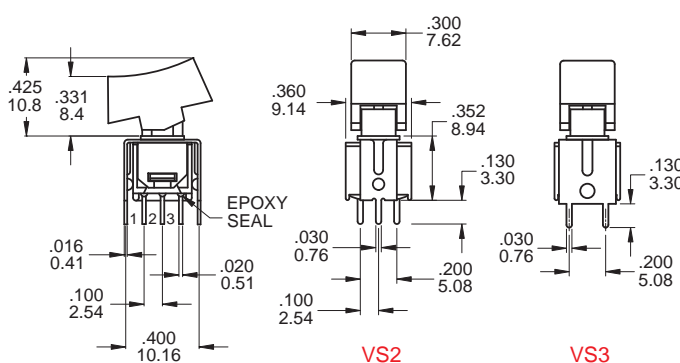

DPDT

Part No. Shown : 4MD1R102VS2QE

SNAP-IN TERMINATION OPTIONS

M6N



M7N

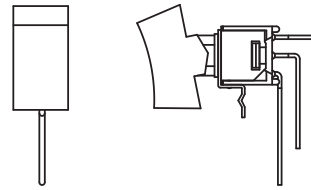

V2N

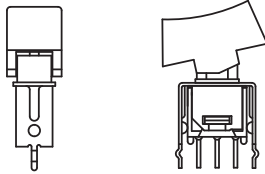

V3N

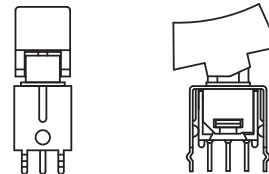

CONTACT MATERIAL OPTIONS

	CONTACT PLATING	TERMINAL PLATING	RATINGS
Q	Silver	Q = Silver	3 Amps with resistant load @ 120VAC or 28VDC 1 Amps with resistant load @ 250VAC
C	Gold over Silver	C = Gold over silver	
R	Gold	R = Gold	0.4 Volt - Amps (VA) max. @ 20V max. (AC or DC)

SOLDERING PROCESSES

MANUAL SOLDERING: Use soldering iron of 30 watts, controlled at 350°C approximately 5 seconds while applying solder.

WAVE SOLDERING: Recommended Soldering Temperature: 270 ± 5°C
Duration of Solder Immersion: Max 5 sec. (PCB is 1.6mm in thickness)

