

4A Series

Sealed Sub-Miniature Rocker Switches

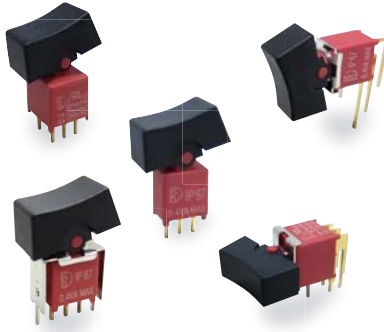

IP 67
ACCORDING TO
EN 60529:1991+A1:2001
IEC 60929:2001

UL US
E 187490

RoHS
compliant

Pb
lead-free

SPECIFICATIONS

CONTACT RATING: Dependent upon contact material See Page 74.

MECHANICAL LIFE: 30,000 make-and-break cycles.

CONTACT RESISTANCE: 20mΩ max. initial @ 2-4VDC
100mA for both silver and gold plated contacts.

INSULATION RESISTANCE: 1,000 MΩ min.

DIELECTRIC STRENGTH: 1,000 Vrms min. @sea level.

OPERATING TEMPERATURE: -30°C to 85°C.

MATERIALS

CASE & BUSHING : Glass filled nylon 6/6, flame retardant,
heat stabilized (UL94V-0).

ACTUATOR: Nylon, black std. Internal O-ring seal standard
with all actuators.

SWITCH SUPPORT: Brass or steel, tin plated.

TERMINAL/CONTACT: Silver or gold plated copper alloy.
(See Page 74)

HOW TO ORDER

MODEL NO. ACTUATOR ACTUATOR COLOR ACTUATOR MARKING TERMINATIONS TERMINAL PLATING SEAL RoHS SOLDERING

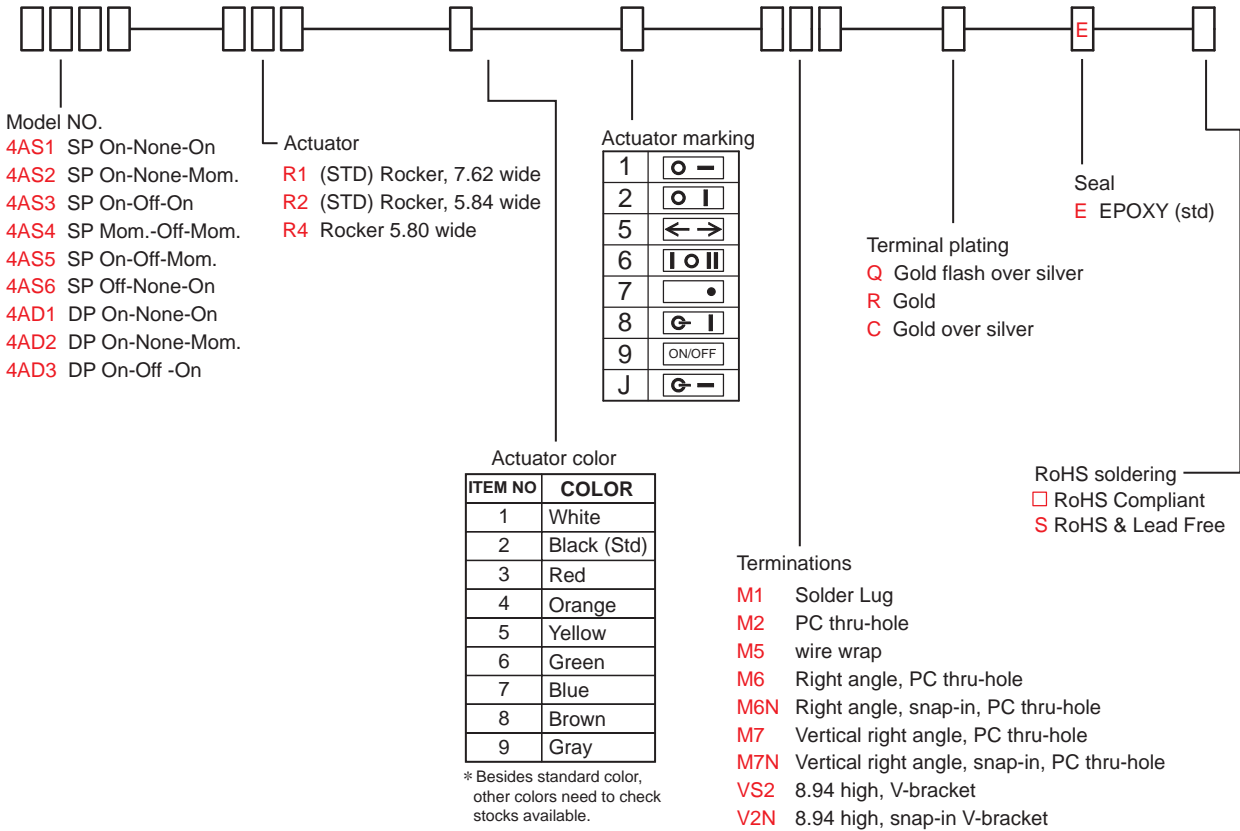

SWITCH FUNCTION

NO. POLES	UL/CSA MODEL NO.	MODEL NO.	SWITCH FUNCTION			CONNECTED TERMINALS / SCHEMATIC		
			POS.1	POS.2	POS.3	POS.1	POS.2	POS.3
SP	Q24A11	4AS1	ON	NONE	ON	2-3	N/A	2-1
	Q24A12	4AS2	ON	NONE	MOM			
	Q24A13	4AS3	ON	OFF	ON		OPEN	
	Q24A14	4AS4	MOM	OFF	MOM			
	Q24A15	4AS5	ON	OFF	MOM	OPEN	N/A	3-1
	Q24A16	4AS6	OFF	NONE	ON			
DP	Q24A21	4AD1	ON	NONE	ON	2-3,5-6	N/A	2-1,5-4
	Q24A22	4AD2	ON	NONE	MOM			
	Q24A23	4AD3	ON	OFF	ON			

MOM=MOMENTARY

POLE OPTIONS



SPDT

Part No. Shown : 4AS1R102M2RE

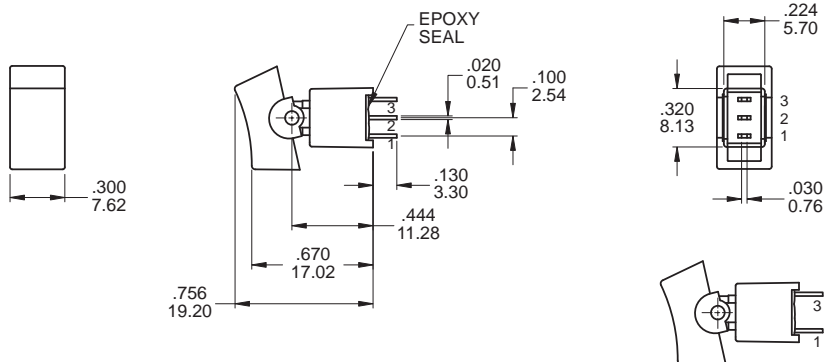

4AS6 Models : Omit 2nd terminal



DPDT

Part No. Shown : 4AD1R102M2QE

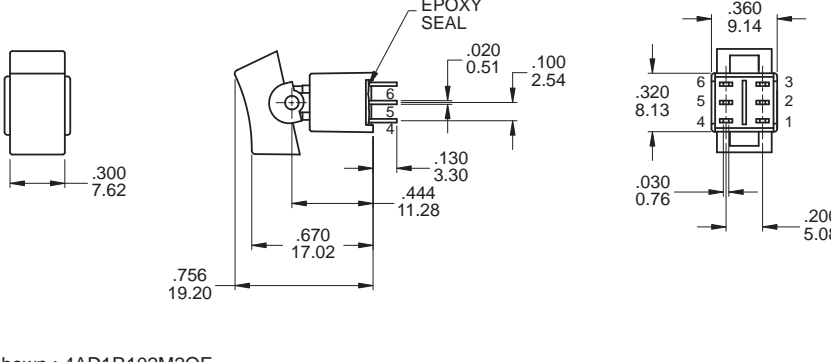



4A Rocker Switches

4A Series

Sealed Sub-Miniature Rocker Switches

ACTUATOR OPTIONS - PANEL MOUNT

R1

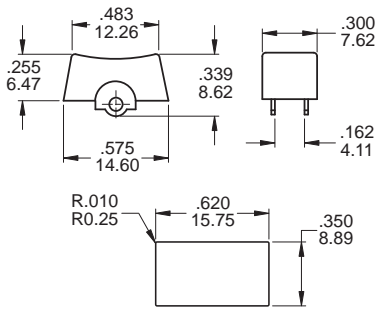

PANEL MOUNTING - R1

R2

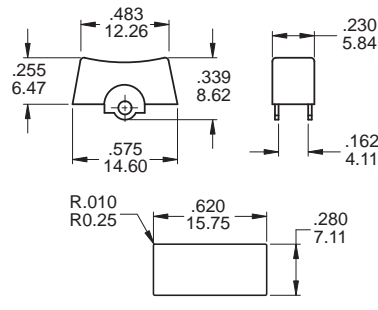

PANEL MOUNTING - R2

R4

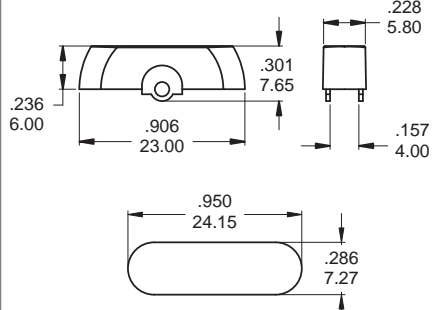

PANEL MOUNTING - R4

TERMINATION OPTIONS

M2 PC Thru-hole

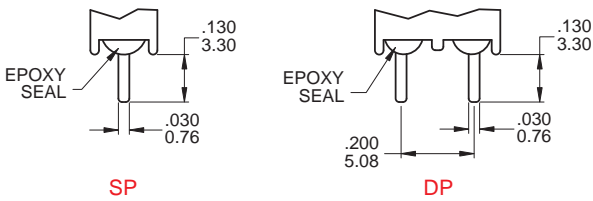

SP

DP

M5 Wire Wrap

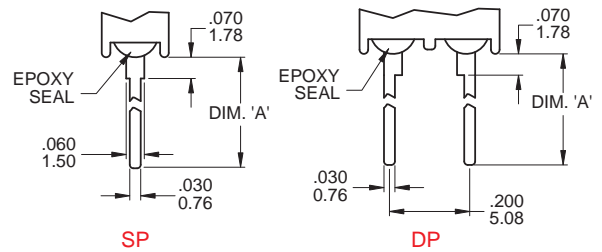

SP

DP

OTHER TERMINATION OPTIONS

M6 Right angle P.C. Mount

M6N Right angle P.C. Mount with snap-in bracket

M7 Right angle P.C. Mount

M7N Right angle P.C. Mount with snap-in bracket

VS2 Vertical bracket P.C. Mount

V2N Vertical bracket P.C. Mount with snap-in bracket

OPTION CODE	DIM. 'A'
M51	.614 (15.60)
M52	.236 (6.00)

M6

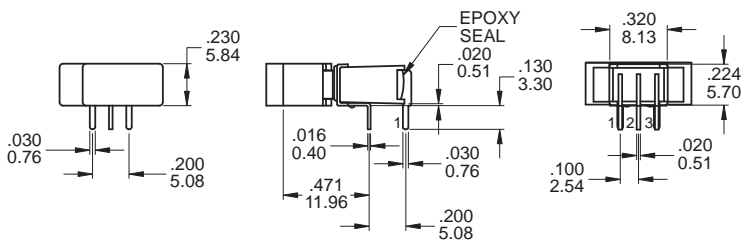

P.C. MOUNTING

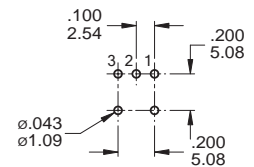

SPDT

Part No. Shown : 4AS1R202M6QE

M6

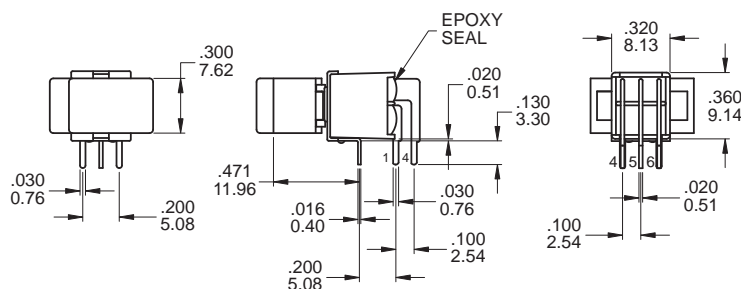

P.C. MOUNTING

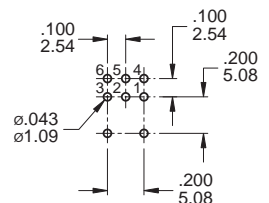

DPDT

Part No. Shown : 4AD1R102M6QE

M7

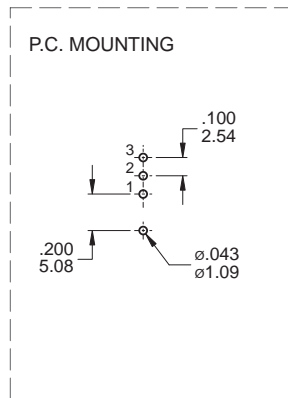
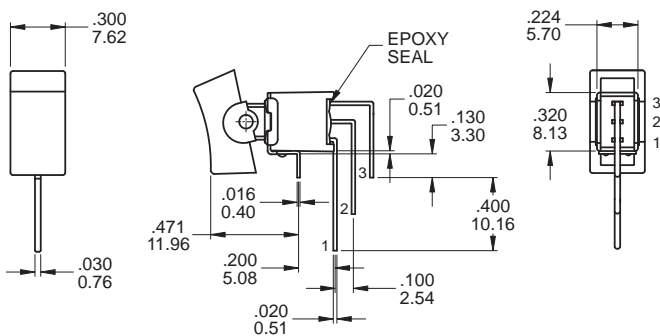

SPDT

Part No. Shown : 4AS1R102M7RE

M7

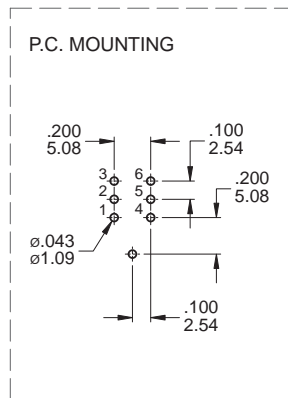
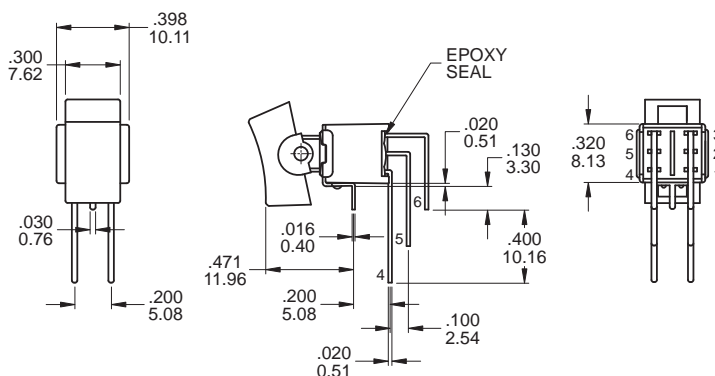
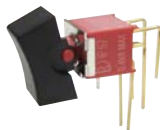

DPDT

Part No. Shown : 4AD1R102M7RE

VS2

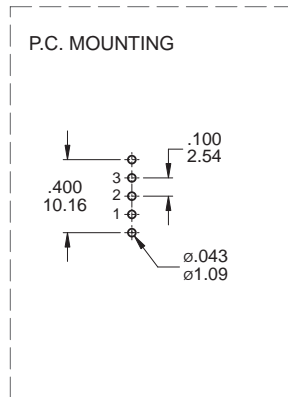
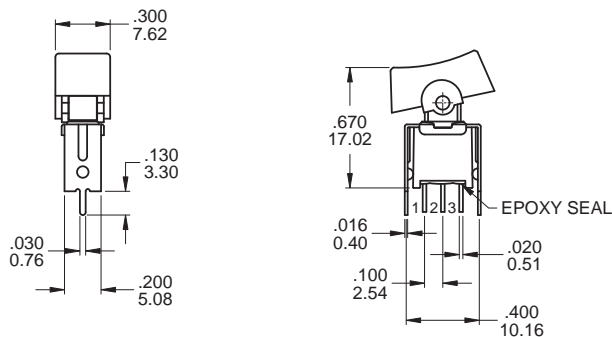

SPDT

Part No. Shown : 4AS1R102VS2RE

VS2

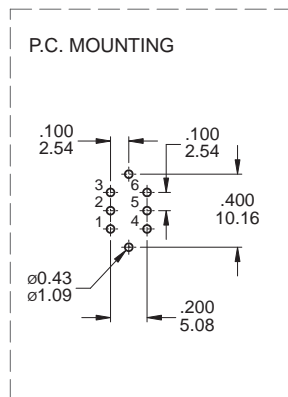
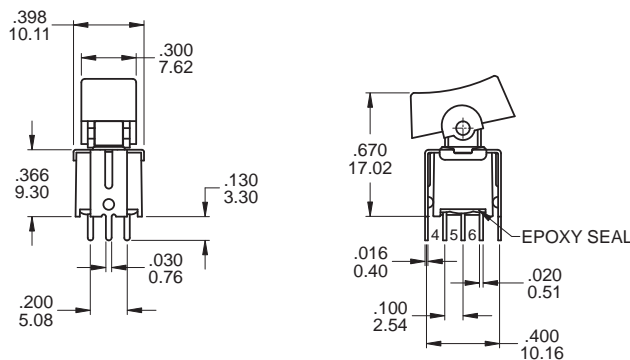

DPDT

Part No. Shown : 4AD1R102VS2QE



4A Series

Sealed Sub-Miniature Rocker Switches

SNAP-IN TERMINATION OPTIONS

M6N

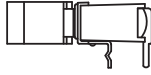
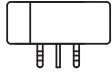

M7N

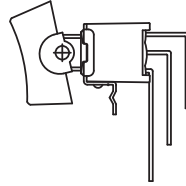
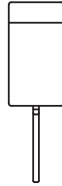

V2N

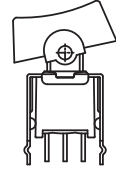

CONTACT MATERIAL OPTIONS

	CONTACT PLATING	TERMINAL PLATING	RATINGS
Q	Silver	Q = Gold flash over silver	3 Amps with resistant load @ 120VAC or 28VDC 1 Amps with resistant load @ 250VAC
C	Gold over Silver	C = Gold over silver	
R	Gold	R = Gold	0.4 Volt - Amps (VA) max. @ 20V max. (AC or DC)

SOLDERING PROCESSES

MANUAL SOLDERING: Use soldering iron of 30 watts, controlled at 350°C approximately 5 seconds while applying solder.

WAVE SOLDERING: Recommended Soldering Temperature: 270 ± 5°C

Duration of Solder Immersion: Max 5 sec. (PCB is 1.6mm in thickness)



4A
Rocker Switches