

Unit: mm

Recommended hole size

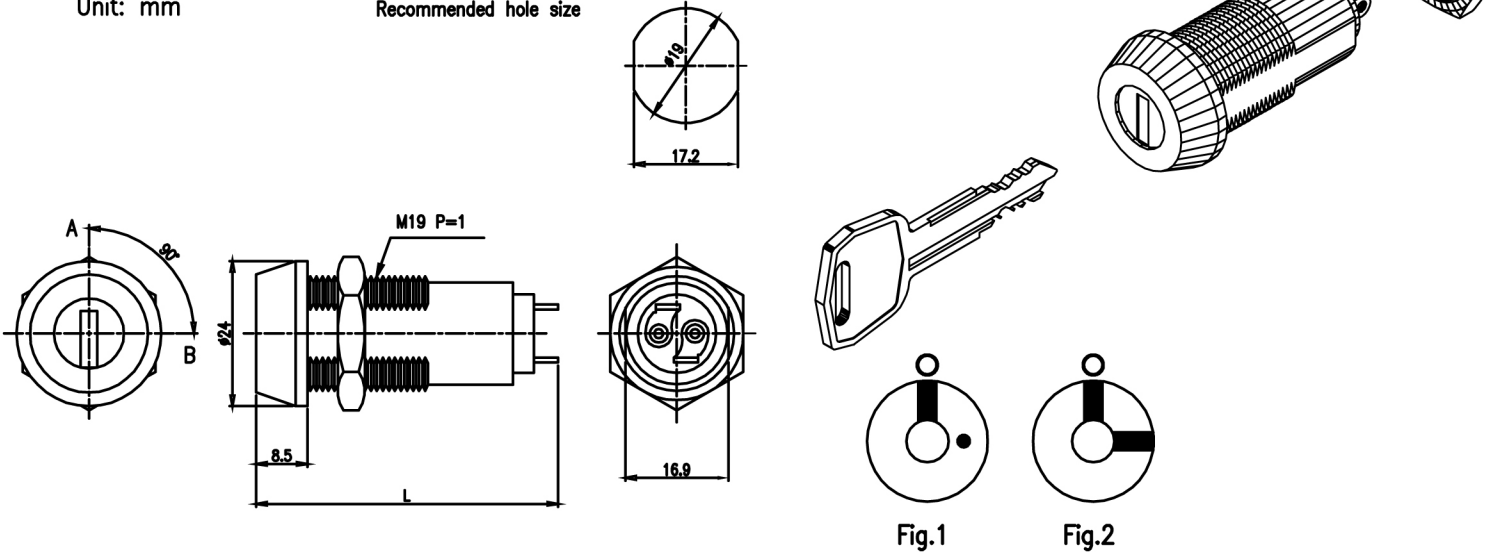

Fig No	Lock Number	Pole	Positions	Terminals	Key Pulls	Turn	⬆	➡	Type
1	S246-1	1	2	2	1	90°	Off	On	SPST
2	S246-2	1	2	2	2	90°	Off	On	SPST
1	S246M	1	2	2	1	90°	Off	On	SPST

Lock Number	L
S246	50.3
S246M	40