

FEATURES

- ※ Compact size, extra thin
- ※ Dual LEDs
- ※ Focused light

APPLICATION

- ※ Server
- ※ Testing Instrument
- ※ Telecommunication

SPECIFICATION

Contact Rating	50mA, 12V DC
Contact Resistance	500mΩ max.
Insulation Resistance	100MΩ min. 100V DC
Dielectric Strength	250V AC/1 minute
Operating Force	160±50gf, 250±100gf
Travel	0.2mm
Operating Life	100, 000 cycles
Operating Temp.	-40°C ~ +85°C
Storage Temp.	-40°C ~ +85°C

HOW TO ORDER

ML3-AG H - - - - - V - R

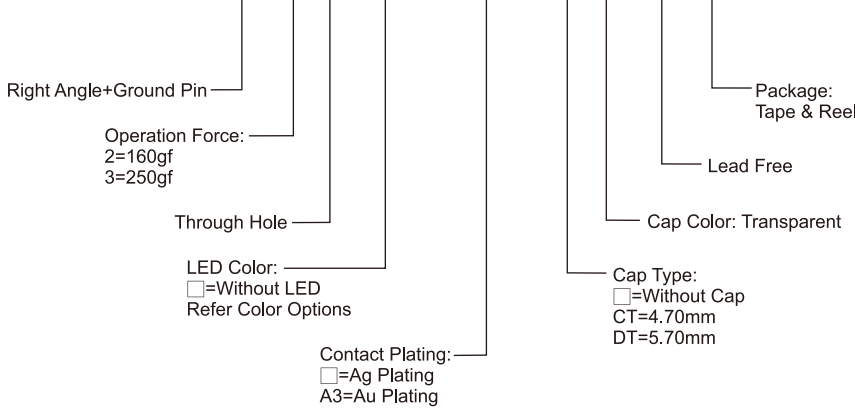

CIRCUIT

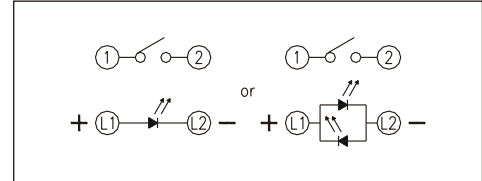

PACKAGE

Without Cap: 600 pcs/reel
With Cap: 300 pcs/reel

ML3

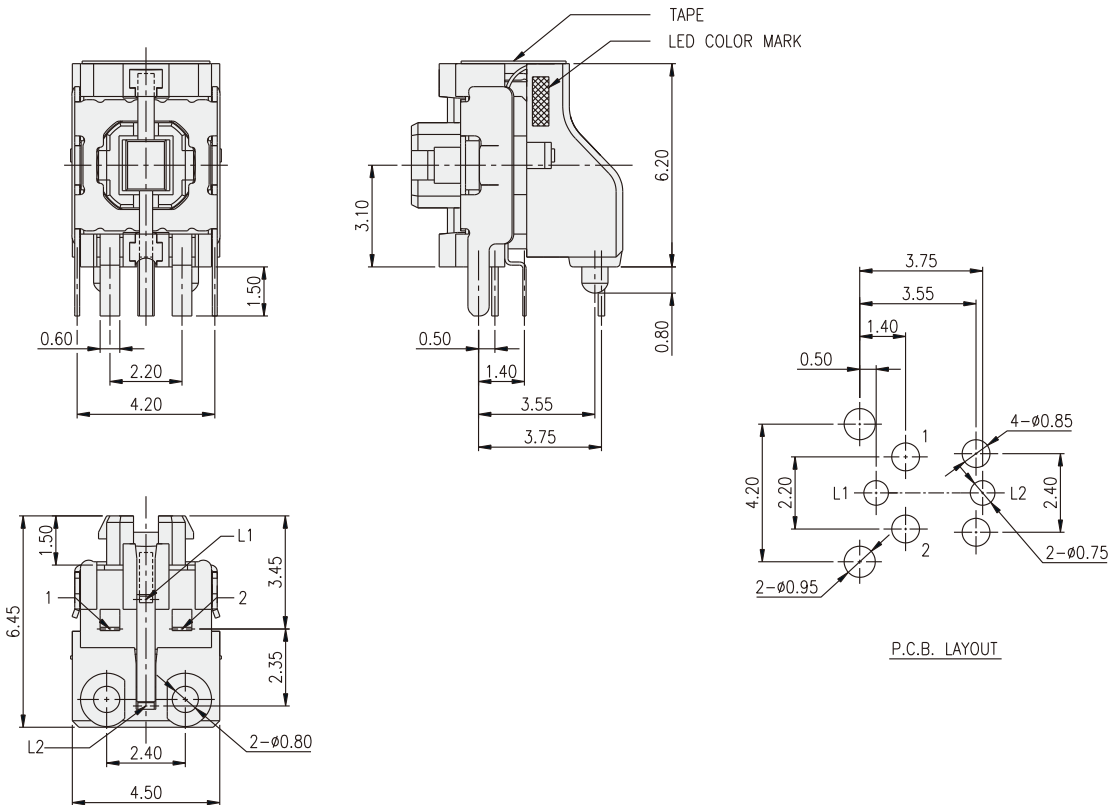

ML3-AG2H

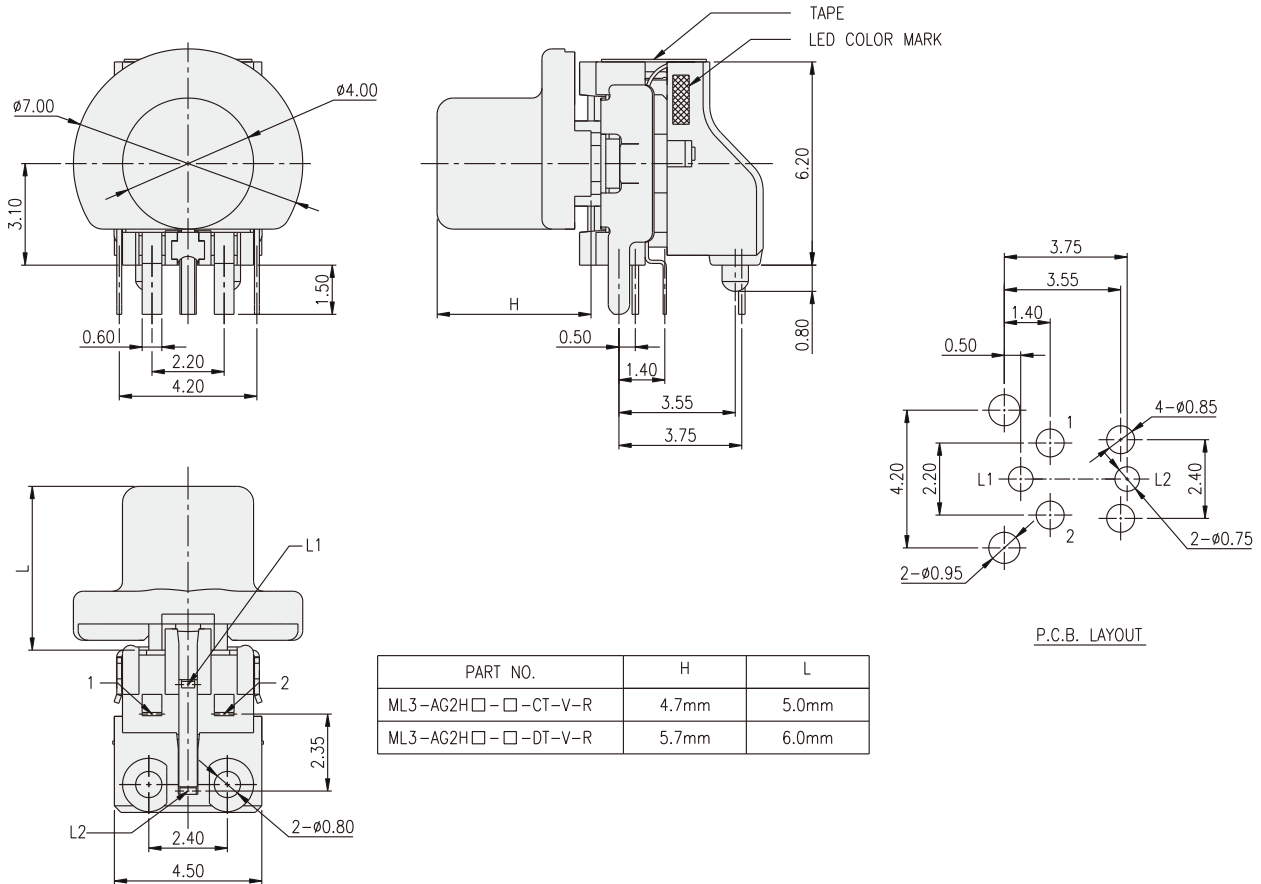

PART NO.	H	L
ML3-AG2H□-□-CT-V-R	4.7mm	5.0mm
ML3-AG2H□-□-DT-V-R	5.7mm	6.0mm

LED Color Options:

Part No.	Color	Dominant Wavelength λ_p Typ.(nm)	Luminous Intensity I_v (mcd)		Forward Voltage V_F (V)		View Angle $2 \cdot \theta_{1/2}$ (Degree)
			Typ.	Max.	Typ.	Max.	
B	Blue	470	50	70	3.0	3.6	140°
PB	Blue	470	70	160	3.0	3.6	
PG	Pure Gree	520	160	30	3.2	3.6	
G	Yellow Green	570	30	60	2.0	2.3	
Y	Yellow	590	60	50	2.0	2.3	
A	Soft Orange	605	50	60	2.0	2.3	
R	Red	630	60	350	2.0	2.3	
W	Cold White	X:0.30 / Y:0.30	350		3.0	3.6	