

FEATURES

- ※ Noiseless switching system
- ※ Long travel
- ※ Sealed type

APPLICATION

- ※ Automotive
- ※ Industrial equipment
- ※ White goods

SPECIFICATION

Contact Rating	1mA~100mA, ≤25V DC
Contact Resistance	free position(680Ω±1.5%) 8.3mm~9.15mm (3380Ω±1.5%) 6.85mm~8.0mm (<=500mΩ)
※ Insulation Resistance	100MΩ min. 500V DC
※ Dielectric Strength	250V AC/1 minute
Operating Force	Actuating Force <= 1.6N
Operating Life	200,000 cycles
Operating Temp.	-40°C ~ +85°C
Storage Temp.	-40°C ~ +85°C

※ Only for without resistors type.

HOW TO ORDER

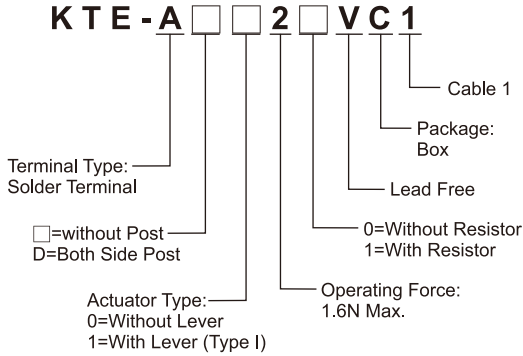

CIRCUIT

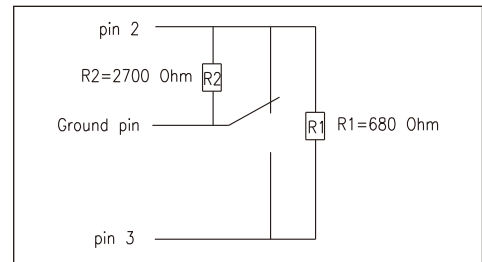

PACKAGE

To be confirmed

KTE

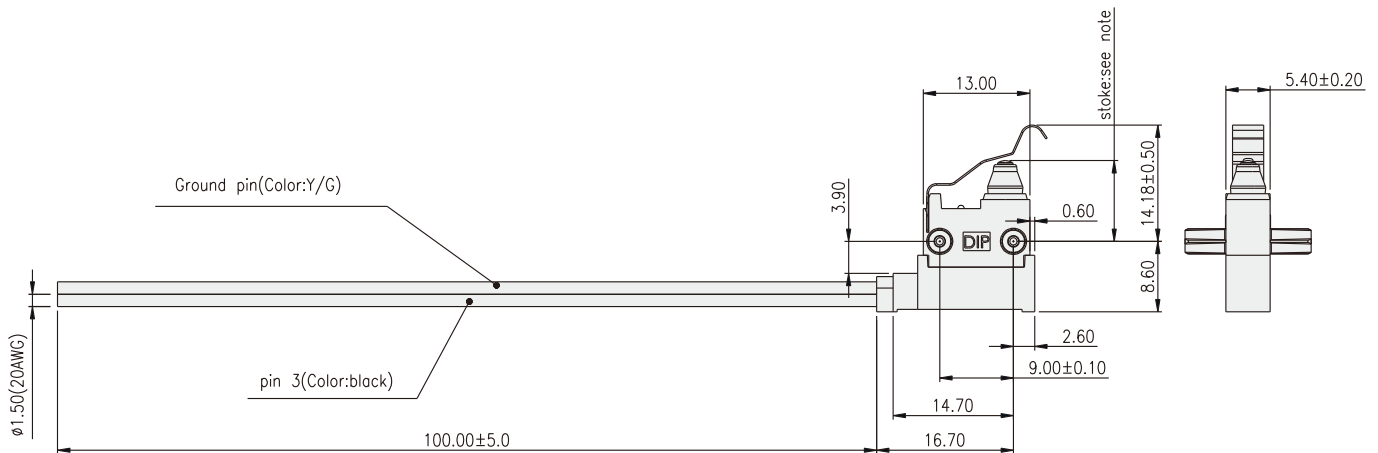

Note:
Stoke: free position 9.85mm (680Ω±1.5%)
8.3mm~9.15mm (3380Ω±1.5%)
6.85mm~8.0mm (<=500mΩ)

