

DO NOT SCALE FROM THIS PRINT

TABLE 1							MATED HEIGHT WITH QSH-01
STYLE	"B"	"C"	BODY (-LC)	BODY (-A)	GROUND PLANE	TERMINAL	
-01	.1680 [4.267]	.1600 [4.064]	QTH-30-01-D-XX	QTH-30-01-D-XX-A	T-1G1-01-X	T-1S39-01-X	.197 [5.00] REF
-02	.2861 [7.267]	.2781 [7.064]	QTH-30-02-D-XX	QTH-30-02-D-XX-A	T-1G1-02-X	T-1S59-02-X	.3150 [8.00] REF

TABLE 2		
POS	"A"	"D"
-030	.788 [20.00]	.728 [18.48]
-060	1.575 [40.01]	1.515 [38.48]
-090	2.363 [60.01]	2.303 [58.48]
-120	3.150 [80.01]	3.090 [78.49]
-150	3.938 [100.01]	3.878 [98.49]

TABLE 3	
No OF POSITIONS	COPLANARITY INCLUDING GROUND PLANE
-030 THRU -060	.004 [0.10]
-090 THRU -150	.006 [0.15]

QTH-XXX-XX-X-D-XXX

No. OF POSITIONS
 -030, -060, -090,
 * -120, * -150 (PER ROW)
 * (SEE NOTE 11)

LEAD STYLE	
-01:	.1680[4.267]
-02:	.2861[7.264]
-03:	.4043[10.269]
-04:	.6001[15.246]
-05:	.7181[18.240]
-06:	.8361[21.237]
-07:	.9542[24.237]
-08:	1.1511[29.238]
-09:	.5224[13.269]
-10:	.5618[14.269]

☐ = SEE TABLE 6, SHT 3

- OPTION**
- LC: LOCKING CLIPS (USE LC-08-TM-01, SEE FIG 2, SHT 2)
 - A: ALIGNMENT PINS (USE QTH-30-XX-D-XX-A FOR -01 & -02) (FOR -03 THRU -10 SEE TABLE 6, SHT 3)
 - K: POLYIMIDE FILM (USE K-DOT-276-375-005) (AVAILABLE ON -01 THRU -04, -09 & -10 ONLY) (SEE FIG 4, SHT 2)
 - TR: TAPE & REEL (-090 POS MAX) (-060 POS MAX W/ -GP OPTION) (N/A ON -05 THRU -08) (SEE FIG 12, SHT 6)
 - GP: GUIDE POSTS (AVAILABLE ON -01 & -02 ONLY) (USE QTH-30-XX-D-XX-X-GP) (SEE FIG 8, SHT 4)
 - FL: FRICTION LOCKS (SEE FIG 9, SHT 4) (NOT AVAILABLE WITH -GP)
 - RT1: RETENTION OPTION (SEE FIG 10, SHT 5) (ONLY AVAILABLE ON -01 LEAD STYLE) (MUST USE -A OPTION) (USE QTH-30-01-D-XX-A-RT1 & T-1R36-01-F) (NOT AVAILABLE WITH -LC, -GP, OR -FL)
 - L: LATCHING OPTION (SEE FIG 11, SHT 5) (ONLY AVAILABLE ON -01 LEAD STYLE) (USE QTH-30-01-D-XX-L) (NOT AVAILABLE WITH -LC, -GP, -FL, OR -RT1) (-060 POS MAX)

ROW SPECIFICATION

- D: DOUBLE (USE QTH-30-XX-D-XX & QTHH-30-XX-D-XX)

PLATING SPECIFICATION

- F: 3 μ" SELECTIVE GOLD IN CONTACT AREA, MATTE TIN ON TAIL (USE T-1SXX-XX-F & T-1GXX-XX-F) (SEE NOTE 7)
- L: 10 μ" SELECTIVE GOLD IN CONTACT AREA, MATTE TIN ON TAIL (USE T-1SXX-XX-L & T-1GXX-XX-L)
- H: 30 μ" GOLD IN CONTACT AREA, 3 μ" GOLD ON TAIL (USE T-1SXX-XX-H & T-1GXX-XX-G)
- C: 50 μ" SELECTIVE GOLD IN CONTACT AREA, MATTE TIN ON TAIL (USE T-1SXX-XX-C, T-1GXX-XX-L)

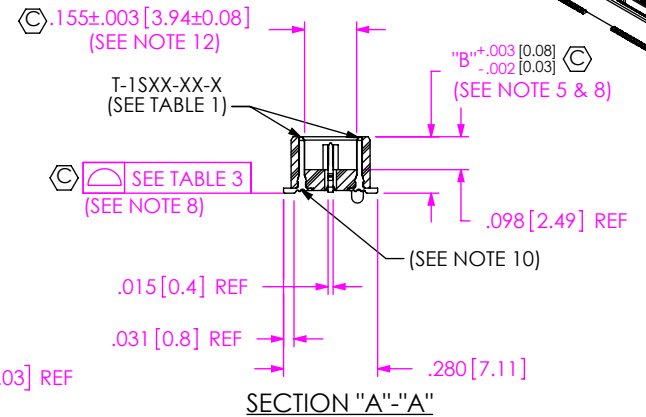
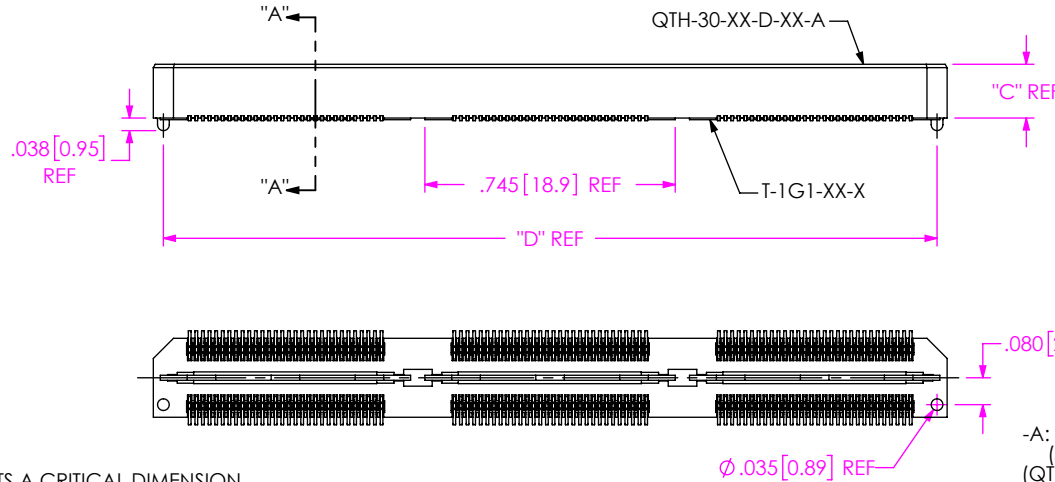
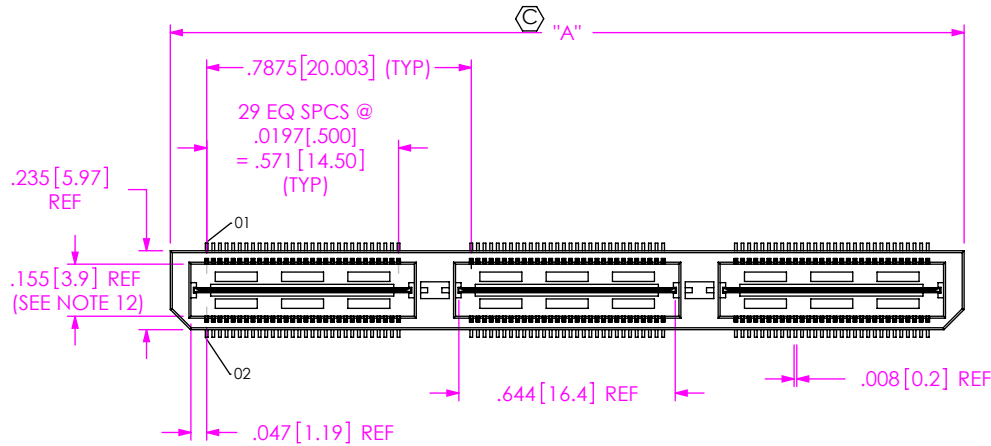

FIG 1
 -A: ALIGNMENT PIN OPTION (STYLE -01 & -02 ONLY) (QTH-090-01-X-D-A SHOWN)

- NOTES:**
- ⊕ REPRESENTS A CRITICAL DIMENSION.
 - MINIMUM PUSHOUT FORCE: 6 OZ FOR -01 & -02, 8 OZ FOR -03 THRU -10.
 - MINIMUM GROUND PLANE RETENTION: 1 LB.
 - PARTS TO BE MOLDED TO POSITION.
 - MAXIMUM VARIANCE OF .002 [0.05]. APPLIES TO SIGNAL OR GROUNDS INDEPENDENT OF THE GROUND OR SIGNAL PINS RESPECTIVELY.
 - LEAD STYLES -03 THRU -10: TOP BODY (QTH) CANNOT HAVE -A OPTION.
 - L PLATING CAN BE SUBSTITUTED FOR -F PLATING.
 - GROUND PLANE PRESS HEIGHT MUST BE .003 [0.07] LESS THAN THE MAXIMUM HEIGHT OR .002 [0.05] GREATER THAN THE MINIMUM HEIGHT OF SIGNAL PIN.
 - T-1R36 RETENTION TO BODY TO BE 1.0 LBF.
 - CUT OFF BURR NOT TO EXCEED .003 [0.08] IN ANY DIRECTION, BURR PLUS TAB HEIGHT NOT TO EXCEED .006 [0.15].
 - FOR NEW APPLICATIONS REQUIRING THESE POSITIONS, PLEASE CONTACT SAMTEC INTERCONNECT PROCESSING GROUP.
 - MAXIMUM PIN CAN EXTEND PAST WALL .003 [0.08]

UNLESS OTHERWISE SPECIFIED, DIMENSIONS ARE IN INCHES.
 TOLERANCES ARE:
 DECIMALS ANGLES
 .XX: ±.01 [0.3]
 .XXX: ±.005 [0.13]
 .XXXX: ±.0020 [0.051]

PROPRIETARY NOTE
 THIS DOCUMENT CONTAINS CONFIDENTIAL AND PROPRIETARY INFORMATION AND ALL DESIGN, MANUFACTURING, REPRODUCTION, USE, PATENT RIGHTS AND SALES RIGHTS ARE EXPRESSLY RESERVED BY SAMTEC, INC. THIS DOCUMENT SHALL NOT BE DISCLOSED, IN WHOLE OR PART, TO ANY UNAUTHORIZED PERSON OR ENTITY NOR REPRODUCED, TRANSFERRED OR INCORPORATED IN ANY OTHER PROJECT IN ANY MANNER WITHOUT THE EXPRESS WRITTEN CONSENT OF SAMTEC, INC.

MATERIAL: DO NOT SCALE DRAWING SHEET SCALE: 1.75:1
 INSULATOR: LCP UL94V-0, COLOR: BLACK
 TERMINAL & GROUND PLANE: PHOS BRONZE



520 PARK EAST BLVD, NEW ALBANY, IN 47150
 PHONE: 812-944-6733 FAX: 812-948-5047
 e-Mail: info@SAMTEC.com code 53322

DESCRIPTION:
 .5mm DOUBLE ROW HS TERMINAL ASSEMBLY
 DWG. NO. QTH-XXX-XX-X-D-XXX
 BY: DEAN P 09-14-2010 SHEET 1 OF 6

FIG 2
-LC LOCKING CLIP OPTION
(QTH-090-01-X-D-LC SHOWN)
(SAME AS FIG 1, EXCEPT AS SHOWN)

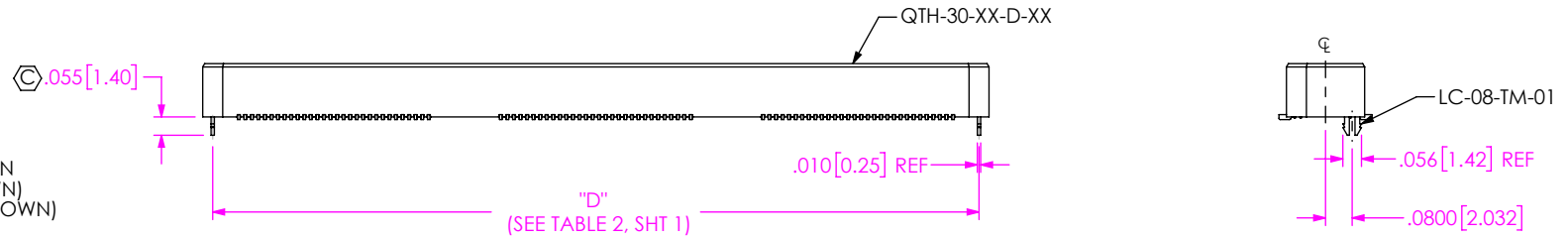
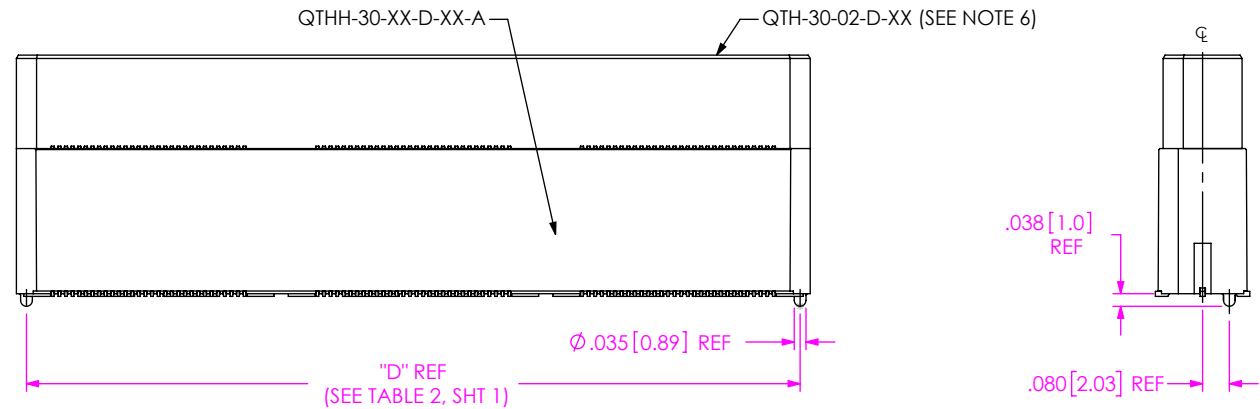

FIG 3
-A: ALIGNMENT PIN OPTION
(QTH-090-05-X-D-A SHOWN)
(SAME AS FIG 1, EXCEPT AS SHOWN)
(STYLES -03 THRU -09, SEE TABLE 6, SHT 3)



No OF POS	"R"				"S"				
	-LC, -A, -FL	-GP	-RT1	-L	-LC, -A, -FL	-GP	-RT1	-L	
-030	.788 [20.00]	1.305 [33.15]	1.438 [36.53]	.906 [23.00]	.256 [6.50]	.515 [13.07]	.581 [14.76]	.315 [7.99]	
-060	1.575 [40.01]	2.093 [53.15]	2.226 [56.53]	1.693 [43.00]	.650 [16.50]	.908 [23.07]	.975 [24.76]	.709 [18.00]	
-090	2.363 [60.01]	2.880 [73.15]	3.013 [76.53]	2.481 [63.00]	1.043 [26.50]	1.302 [33.07]	1.369 [34.76]	1.102 [28.00]	
-120	3.150 [80.01]	3.668 [93.15]	3.801 [96.53]	3.268 [83.01]	1.437 [36.50]	1.696 [43.07]	1.762 [44.76]	1.496 [38.00]	
-150	3.938 [100.01]	4.455 [113.16]	4.588 [116.54]	4.056 [103.01]	1.831 [46.50]	2.090 [53.07]	2.156 [54.76]	1.890 [48.00]	

STYLE	"T"
-01	.173 [4.39]
-02	.290 [7.37]
-03	.409 [10.39]
-04	.605 [15.37]
-09	.527 [13.39]
-10	.566 [14.38]

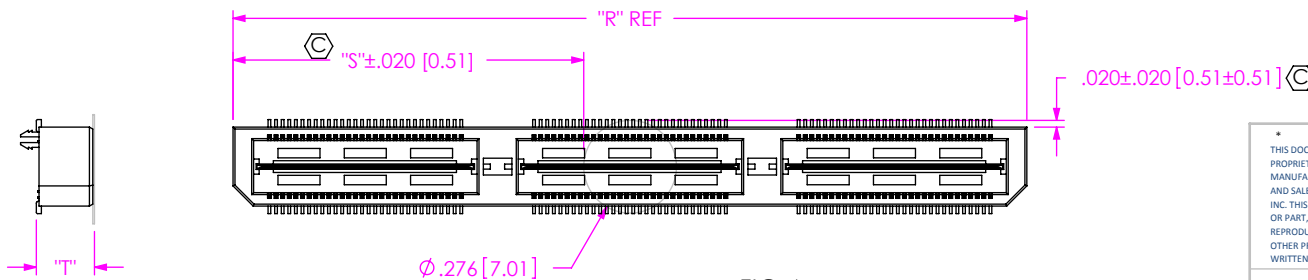

FIG 4
-K: POLYIMIDE FILM PAD OPTION
(USE K-DOT-.276-.375-.005)

PROPRIETARY NOTE
THIS DOCUMENT CONTAINS CONFIDENTIAL AND PROPRIETARY INFORMATION AND ALL DESIGN, MANUFACTURING, REPRODUCTION, USE, PATENT RIGHTS AND SALES RIGHTS ARE EXPRESSLY RESERVED BY SAMTEC, INC. THIS DOCUMENT SHALL NOT BE DISCLOSED, IN WHOLE OR PART, TO ANY UNAUTHORIZED PERSON OR ENTITY NOR REPRODUCED, TRANSFERRED OR INCORPORATED IN ANY OTHER PROJECT IN ANY MANNER WITHOUT THE EXPRESS WRITTEN CONSENT OF SAMTEC, INC.



520 PARK EAST BLVD, NEW ALBANY, IN 47150
PHONE: 812-944-6733 FAX: 812-948-5047
e-Mail info@SAMTEC.com code 55322

DO NOT SCALE DRAWING

SHEET SCALE: 1:75:1

DESCRIPTION:
.5mm DOUBLE ROW HS TERMINAL ASSEMBLY

DWG. NO. **QTH-XXX-XX-X-D-XXX**

BY: DEAN P 09-14-2010 SHEET 2 OF 6

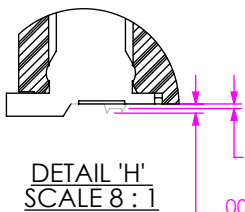

.003[0.08] MAX
TAB HEIGHT
.006[0.15] MAX BURR
+ TAB HEIGHT

TABLE 6									MATED HEIGHT WITH QSH-01
STYLE	SEE FIGURE	"E" OVERALL HEIGHT	GROUND PLANE	TERMINAL	TOP BODY (SEE NOTE 6)	BOTTOM SPACER BODY (-LC OR NONE)	BOTTOM SPACER BODY (-A)		
-03	5	.4043 [10.269]	T-1G1-03-X	T-1S60-03-X	QTH-30-02-D-XX	QTHH-30-01-D-XX	QTHH-30-01-D-XX-A	.433 [11.00]	REF
-04	5	.6001 [15.243]	T-1G1-04-X	T-1S60-04-X	QTH-30-02-D-XX	QTHH-30-01-D-XX	QTHH-30-01-D-XX-A	.630 [16.00]	REF
-05	6	.7181 [18.240]	T-1G1-05-X	T-1S60-05-X	QTH-30-02-D-XX	QTHH-30-03-D-XX	QTHH-30-03-D-XX-A	.748 [19.00]	REF
-06	6	.8361 [21.237]	T-1G1-06-X	T-1S60-06-X	QTH-30-02-D-XX	QTHH-30-03-D-XX	QTHH-30-03-D-XX-A	.866 [22.00]	REF
-07	7	.9542 [24.237]	T-1G1-07-1-X	T-1S61-21-X	QTH-30-02-D-XX	QTHH-30-04-D-XX	QTHH-30-04-D-XX-A	.984 [24.99]	REF
-08	7	1.1511 [29.238]	T-1G1-07-2-X	T-1S61-22-X	QTH-30-02-D-XX	QTHH-30-04-D-XX	QTHH-30-04-D-XX-A	1.181 [30.00]	REF
-09	5	.5224 [13.269]	T-1G1-09-X	T-1S60-09-X	QTH-30-02-D-XX	QTHH-30-01-D-XX	QTHH-30-01-D-XX-A	.551 [14.00]	REF
-10	5	.5618 [14.270]	T-1G1-10-X	T-1S60-10-X	QTH-30-02-D-XX	QTHH-30-01-D-XX	QTHH-30-01-D-XX-A	.591 [15.01]	REF

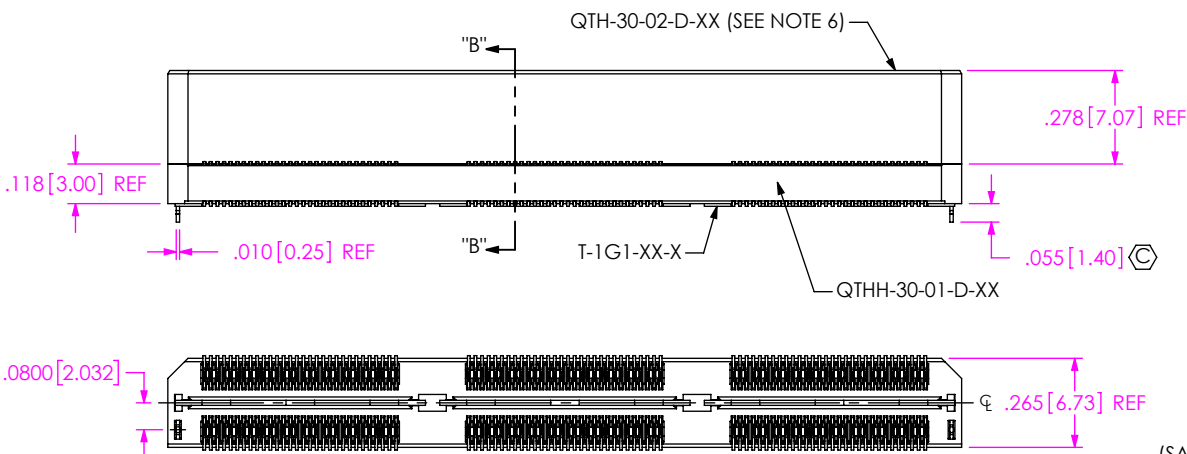
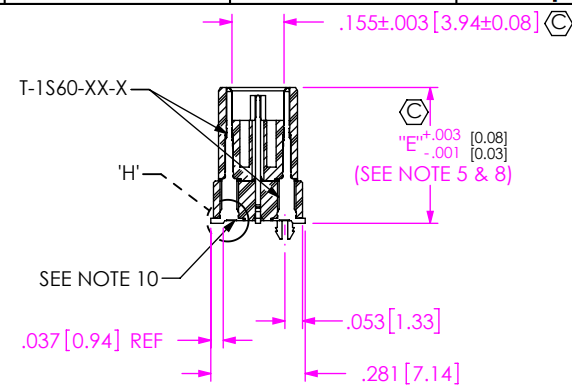

FIG 5
(QTH-090-03-X-D-LC SHOWN)
(SAME AS FIG 1, EXCEPT AS SHOWN)



SECTION "B"-"B"

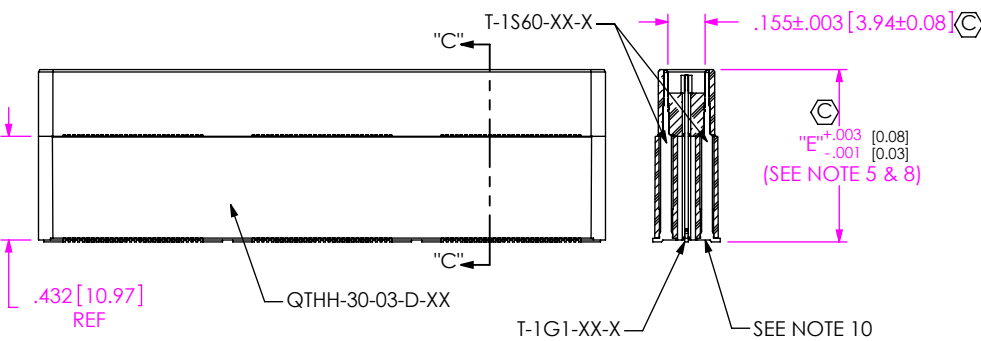

FIG 6
(QTH-090-05-X-D SHOWN)
(SAME AS FIG 5, EXCEPT AS SHOWN)

SECTION "C"-"C"
SCALE 1.25 : 1

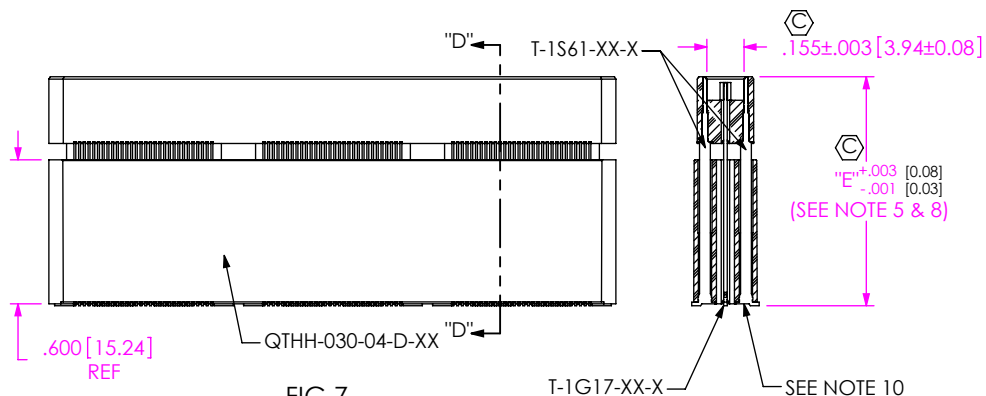

FIG 7
(QTH-090-07-X-D SHOWN)
(SAME AS FIG 5, EXCEPT AS SHOWN)

SECTION "D"-"D"
SCALE 1.25 : 1

PROPRIETARY NOTE
THIS DOCUMENT CONTAINS CONFIDENTIAL AND PROPRIETARY INFORMATION AND ALL DESIGN, MANUFACTURING, REPRODUCTION, USE, PATENT RIGHTS AND SALES RIGHTS ARE EXPRESSLY RESERVED BY SAMTEC, INC. THIS DOCUMENT SHALL NOT BE DISCLOSED, IN WHOLE OR PART, TO ANY UNAUTHORIZED PERSON OR ENTITY NOR REPRODUCED, TRANSFERRED OR INCORPORATED IN ANY OTHER PROJECT IN ANY MANNER WITHOUT THE EXPRESS WRITTEN CONSENT OF SAMTEC, INC.



520 PARK EAST BLVD, NEW ALBANY, IN 47150
PHONE: 812-944-6733 FAX: 812-948-5047
e-Mail info@SAMTEC.com code 55322

DO NOT SCALE DRAWING
SHEET SCALE: 1:0.571429

DESCRIPTION:
.5mm DOUBLE ROW HS TERMINAL ASSEMBLY

DWG. NO. QTH-XXX-XX-X-D-XXX

BY: DEAN P 09-14-2010 SHEET 3 OF 6

TABLE 7		
POS	"F"	"G"
-030	1.305 [33.15]	1.013 [25.72]
-060	2.093 [53.15]	1.800 [45.72]
-090	2.880 [73.15]	2.588 [65.72]
-120	3.668 [93.15]	3.375 [85.73]
-150	4.455 [113.16]	4.163 [105.73]

TABLE 8		
STYLE	"H"	BODY
-01	.3630 [9.220]	QTH-30-01-D-XX-X-GP
-02	.4810 [12.217]	QTH-30-02-D-XX-X-GP

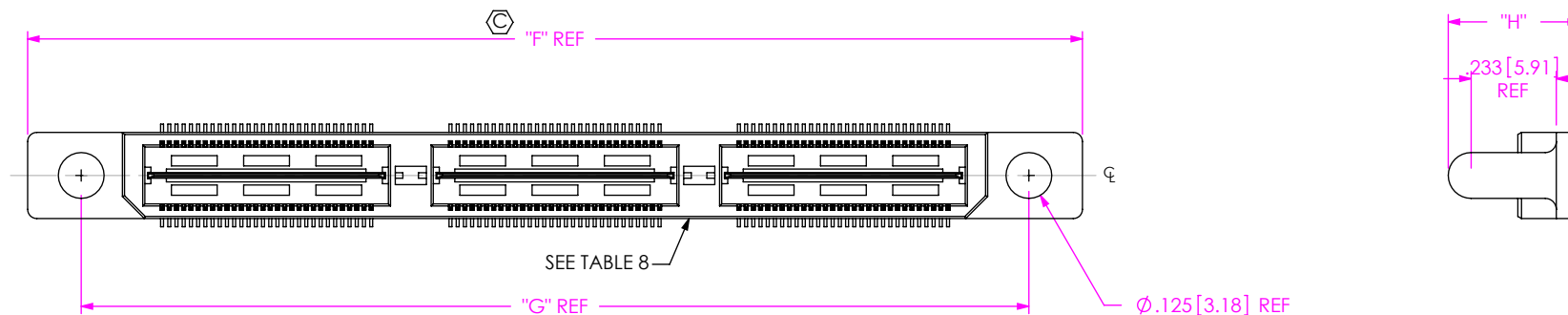

FIG 8
(QTH-090-01-X-D-GP SHOWN)
(SAME AS FIG 1, EXCEPT AS SHOWN)
(AVAILABLE ON -01 & -02 ONLY)

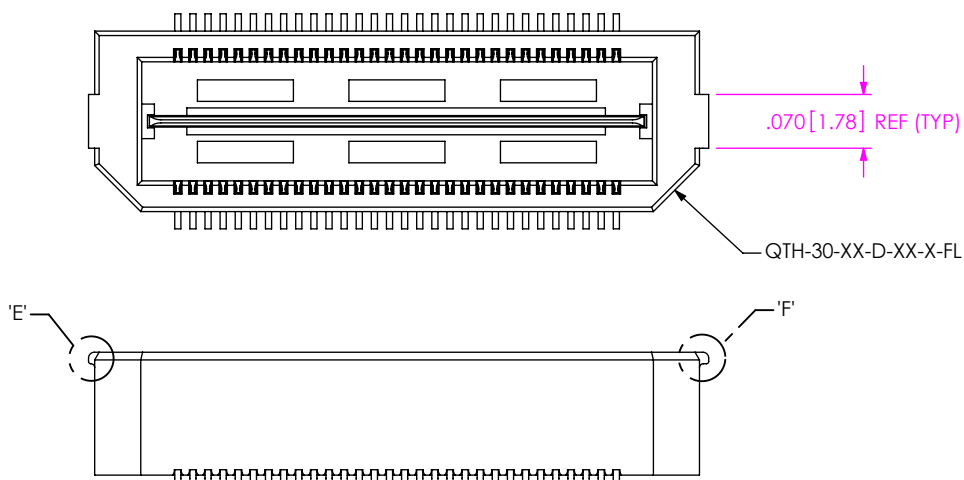
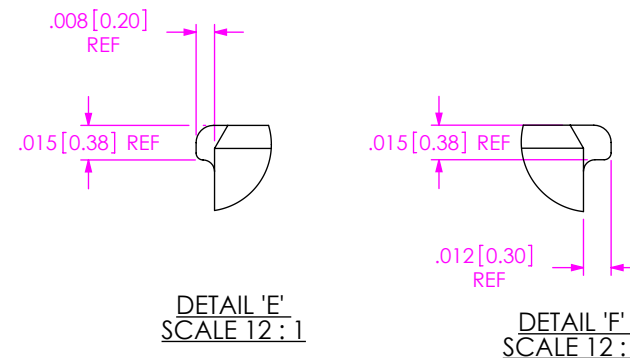

FIG 9
-FL: FRICTION LOCKS
(NOT AVAILABLE WITH -GP OPTION)
(SAME AS FIG 1, EXCEPT AS SHOWN)



DETAIL 'E'
SCALE 12 : 1

DETAIL 'F'
SCALE 12 : 1

PROPRIETARY NOTE
THIS DOCUMENT CONTAINS CONFIDENTIAL AND PROPRIETARY INFORMATION AND ALL DESIGN, MANUFACTURING, REPRODUCTION, USE, PATENT RIGHTS AND SALES RIGHTS ARE EXPRESSLY RESERVED BY SAMTEC, INC. THIS DOCUMENT SHALL NOT BE DISCLOSED, IN WHOLE OR PART, TO ANY UNAUTHORIZED PERSON OR ENTITY NOR REPRODUCED, TRANSFERRED OR INCORPORATED IN ANY OTHER PROJECT IN ANY MANNER WITHOUT THE EXPRESS WRITTEN CONSENT OF SAMTEC, INC.



520 PARK EAST BLVD, NEW ALBANY, IN 47150
PHONE: 812-944-6733 FAX: 812-948-5047
e-Mail info@SAMTEC.com code 55322

DO NOT SCALE DRAWING

SHEET SCALE: 2:1

DESCRIPTION:
.5mm DOUBLE ROW HS TERMINAL ASSEMBLY

DWG. NO. QTH-XXX-XX-X-D-XXX

BY: DEAN P 09-14-2010 SHEET 4 OF 6

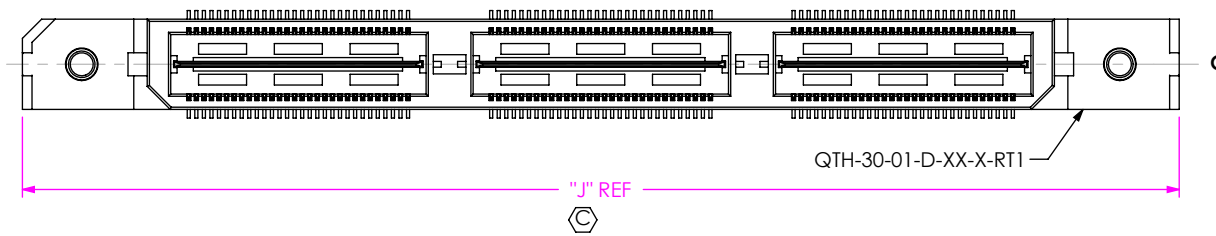

TABLE 9		
POS	"J"	"K"
-030	1.438 [36.53]	1.129 [28.68]
-060	2.226 [56.53]	1.917 [48.68]
-090	3.013 [76.53]	2.704 [68.68]
-120	3.801 [96.53]	3.492 [88.68]
-150	4.588 [116.54]	4.279 [108.69]

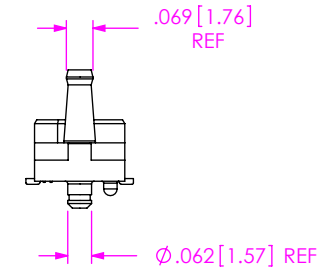
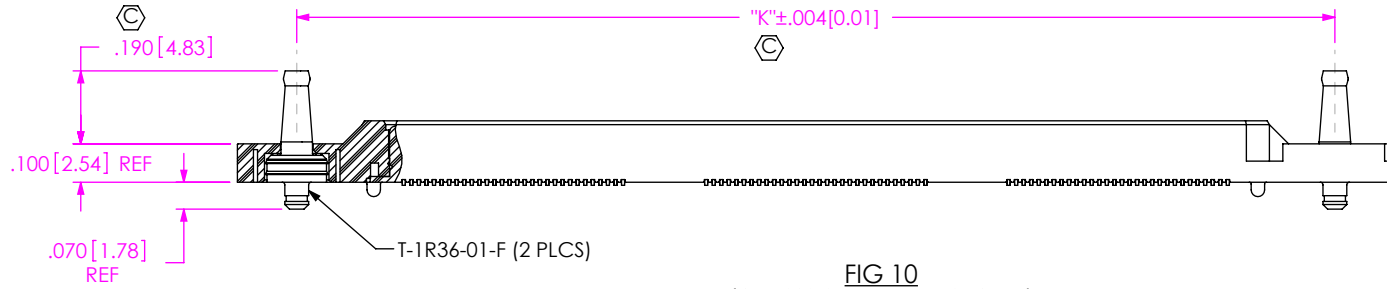

FIG 10
(QTH-090-01-X-D-A-RT1 SHOWN)
(NOT AVAILABLE WITH -LC, -GP, OR -FL OPTIONS)
(AVAILABLE ON -01 ONLY)
(SAME AS FIG 1, EXCEPT AS SHOWN)

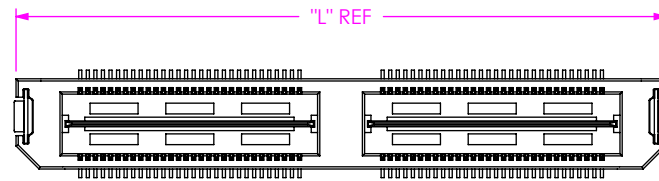

TABLE 10			
POS	"L"	"M"	"N"
-030	.906 [23.00]	.915 [23.24]	.854 [21.69]
-060	1.693 [43.00]	1.703 [43.24]	1.642 [41.69]
*-090	2.481 [63.00]	2.490 [63.25]	2.429 [61.70]

(* = NOT RELEASED)

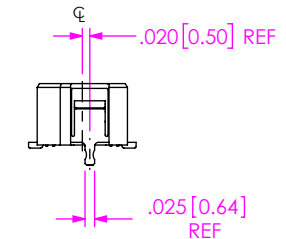
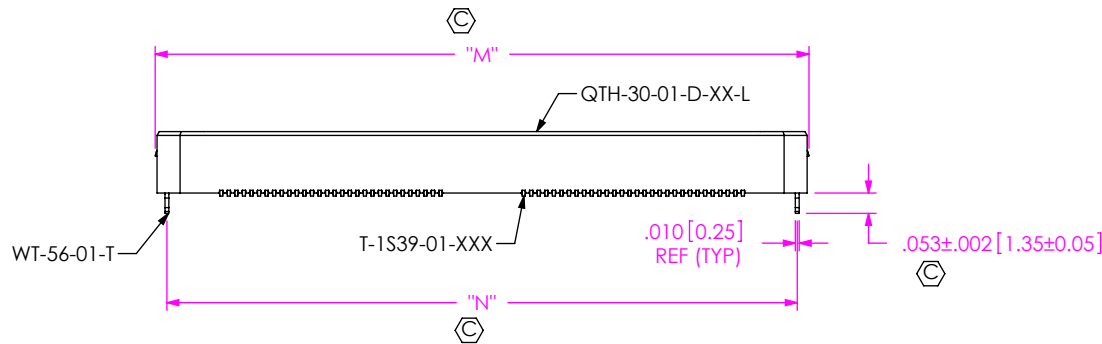
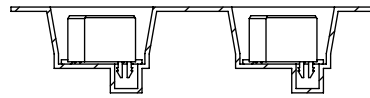
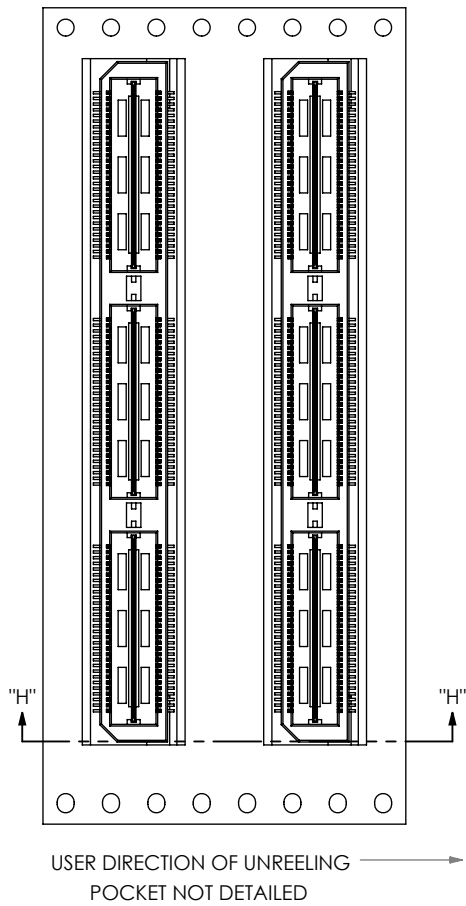

FIG 11
L: LATCHING OPTION
(QTH-060-01-X-D-L SHOWN)
(AVAILABLE ON -01 LEAD STYLE ONLY)
(NOT AVAILABLE WITH -LC, -GP, -FL, OR -RT1 OPTIONS)
(SAME AS FIG 1, EXCEPT AS SHOWN)

<p>DO NOT SCALE DRAWING</p> <p>SHEET SCALE: 2:1</p>	<p>PROPRIETARY NOTE</p> <p>THIS DOCUMENT CONTAINS CONFIDENTIAL AND PROPRIETARY INFORMATION AND ALL DESIGN, MANUFACTURING, REPRODUCTION, USE, PATENT RIGHTS AND SALES RIGHTS ARE EXPRESSLY RESERVED BY SAMTEC, INC. THIS DOCUMENT SHALL NOT BE DISCLOSED, IN WHOLE OR PART, TO ANY UNAUTHORIZED PERSON OR ENTITY NOR REPRODUCED, TRANSFERRED OR INCORPORATED IN ANY OTHER PROJECT IN ANY MANNER WITHOUT THE EXPRESS WRITTEN CONSENT OF SAMTEC, INC.</p>	<p>samtec</p> <p>520 PARK EAST BLVD. NEW ALBANY, IN 47150 PHONE: 812-944-6733 FAX: 812-948-5047 e-Mail info@SAMTEC.com code 55322</p>
	<p>DESCRIPTION: .5mm DOUBLE ROW HS TERMINAL ASSEMBLY</p>	
	<p>DWG. NO. QTH-XXX-XX-X-D-XXX</p>	
<p>BY: DEAN P 09-14-2010 SHEET 5 OF 6</p>		



SECTION "H"-"H"
SCALE 1.5 : 1

FIG 12
-TR: TAPE & REEL
(QTH-090-01-X-D-LC-TR SHOWN)
(-090 POS MAX)
(-060 POS MAX W/-GP OPTION)
(N/A ON -05 THRU -08)
(SAME AS FIG 1, EXCEPT AS SHOWN)

PROPRIETARY NOTE
THIS DOCUMENT CONTAINS CONFIDENTIAL AND PROPRIETARY INFORMATION AND ALL DESIGN, MANUFACTURING, REPRODUCTION, USE, PATENT RIGHTS AND SALES RIGHTS ARE EXPRESSLY RESERVED BY SAMTEC, INC. THIS DOCUMENT SHALL NOT BE DISCLOSED, IN WHOLE OR PART, TO ANY UNAUTHORIZED PERSON OR ENTITY NOR REPRODUCED, TRANSFERRED OR INCORPORATED IN ANY OTHER PROJECT IN ANY MANNER WITHOUT THE EXPRESS WRITTEN CONSENT OF SAMTEC, INC.



520 PARK EAST BLVD, NEW ALBANY, IN 47150
PHONE: 812-944-6733 FAX: 812-948-5047
e-Mail info@SAMTEC.com code 55322

DO NOT SCALE DRAWING
SHEET SCALE: 1:1

DESCRIPTION:
.5mm DOUBLE ROW HS TERMINAL ASSEMBLY
DWG. NO. QTH-XXX-XX-X-D-XXX

BY: DEAN P 09-14-2010 SHEET 6 OF 6