



RFM Integrated Device, Inc.

## PRODUCT SPECIFICATION

Part Number: SF2645J

SAW DIPLEXER, 1197.5/1584.5 MHz  
(BW 63/51 MHz)

**Preliminary**

**A. MAXIMUM RATING:**

1. Input Power Level: 15 dBm
2. DC Voltage : 0 V
3. Operating Temperature: -40°C to +105°C
4. Storage Temperature: -40°C to +105°C
5. Moisture Sensitive Level: MSL 3

**B. ELECTRICAL CHARACTERISTICS:**

- Terminating source impedance (single) :  $Z_s = 50 \Omega$   
 Terminating load impedance (single) :  $Z_L = 50 \Omega$

Item (L2+L5 Band to Antenna)	Unit	Min.	Typ.	Max.
<b>Center frequency</b>	MHz	-	1197.5	-
<b>Insertion Loss</b> (1166 ~ 1229 MHz)	dB	-	2.8	3.5
<b>Amplitude Ripple</b> (1166 ~ 1229 MHz)	dB(p-p)	-	0.6	2.0
<b>Attenuation</b> (reference level from 0 dB)				
10 ~ 925 MHz	dB	30	40	-
925 ~ 960 MHz	dB	30	35	-
1427 ~ 1463 MHz	dB	25	32	-
1574 ~ 1606 MHz (L1 Band)	dB	25	33	-
1850 ~ 1980 MHz	dB	25	30	-
<b>Temperature Coefficient of Frequency</b>	ppm/K	-	-36	-

Item (L1 Band to Antenna)	Unit	Min.	Typ.	Max.
<b>Center frequency</b>	MHz	-	1584.5	-
<b>Insertion Loss (1559 ~ 1610 MHz)</b>	dB	-	2.8	3.5
<b>Amplitude Ripple (1559 ~ 1610 MHz)</b>	dB(p-p)	-	0.5	2.0
<b>Attenuation (reference level from 0 dB)</b>				
10 ~ 960 MHz	dB	25	32	-
1166 ~ 1229 MHz (L2+L5 Band)	dB	30	34	-
1427 ~ 1463 MHz	dB	30	35	-
1710 ~ 1785 MHz	dB	25	30	-
1850 ~ 1910 MHz	dB	25	32	-
1910 ~ 1980 MHz	dB	30	35	-
<b>Temperature Coefficient of Frequency</b>	ppm/K	-	-36	-

Item (Isolation)	Unit	Min.	Typ.	Max.
<b>Attenuation (reference level from 0 dB)</b>				
1166 ~ 1229 MHz (L2+L5 Band)	dB	30	38	-
1574 ~ 1606 MHz (L1 Band)	dB	30	48	-
<b>Temperature Coefficient of Frequency</b>	ppm/K	-	-36	-

**C. TEST CIRCUIT:**

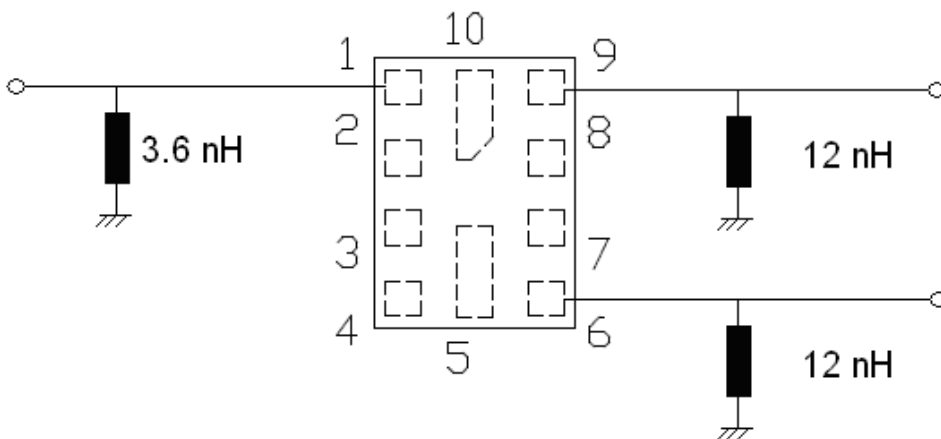

**D. OUTLINE DRAWING:**

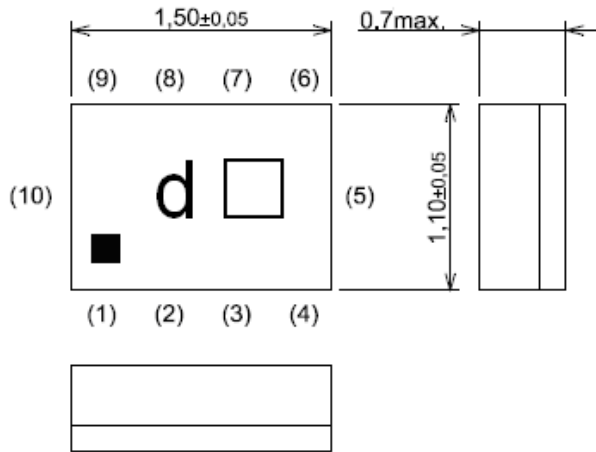

Pin #	Function
(1)	Antenna
(2)	Ground
(3)	Ground
(4)	Ground
(5)	Ground
(6)	L1 Band
(7)	Ground
(8)	Ground
(9)	L2+L5 Band
(10)	Ground

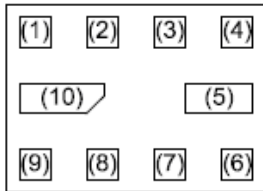

Year/Month	1	2	3	4	5	6	7	8	9	10	11	12
2021	A	B	C	D	E	F	G	H	J	K	L	M
2022	N	P	Q	R	S	T	U	V	W	X	Y	Z
2023	a	b	c	d	e	f	g	h	j	k	l	m
2024	n	p	q	r	s	t	u	v	w	x	y	z
2025	<u>A</u>	<u>B</u>	<u>C</u>	<u>D</u>	<u>E</u>	<u>F</u>	<u>G</u>	<u>H</u>	<u>J</u>	<u>K</u>	<u>L</u>	<u>M</u>
2026	<u>N</u>	<u>P</u>	<u>Q</u>	<u>R</u>	<u>S</u>	<u>T</u>	<u>U</u>	<u>V</u>	<u>W</u>	<u>X</u>	<u>Y</u>	<u>Z</u>
2027	<u>a</u>	<u>b</u>	<u>c</u>	<u>d</u>	<u>e</u>	<u>f</u>	<u>g</u>	<u>h</u>	<u>j</u>	<u>k</u>	<u>l</u>	<u>m</u>
2028	<u>n</u>	<u>p</u>	<u>q</u>	<u>r</u>	<u>s</u>	<u>t</u>	<u>u</u>	<u>v</u>	<u>w</u>	<u>x</u>	<u>y</u>	<u>z</u>

## E. Frequency Characteristics:

### L2+L5 Pass Band

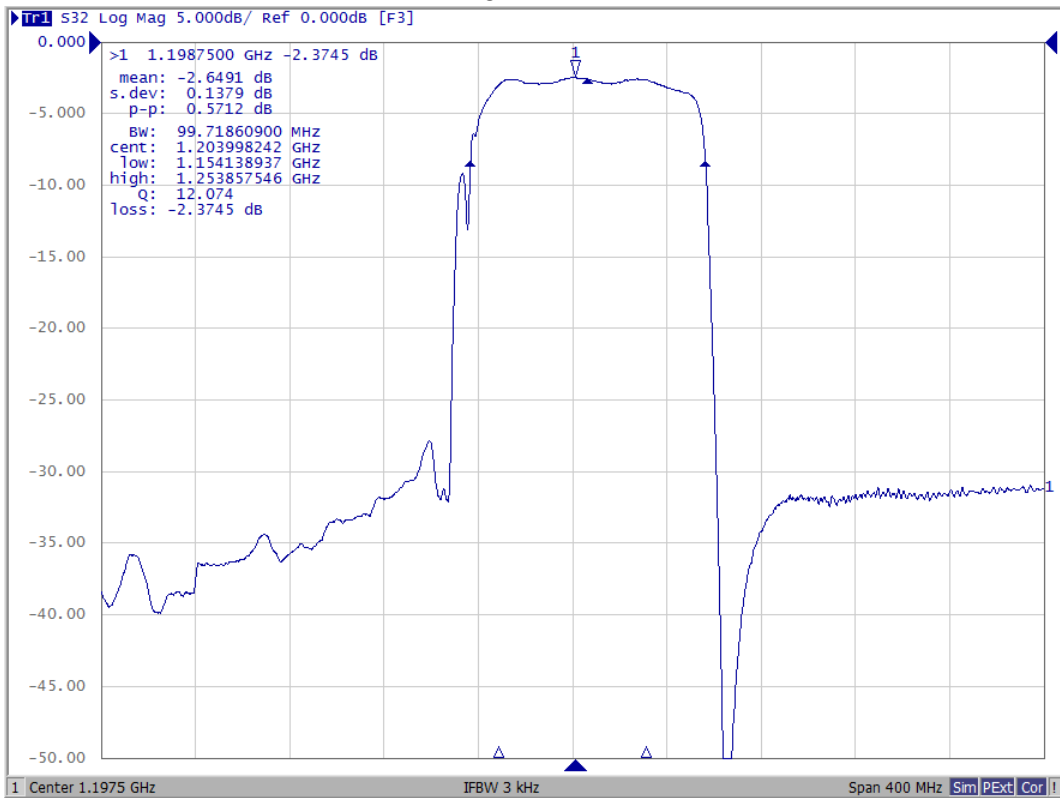

### L2+L5 Full Range

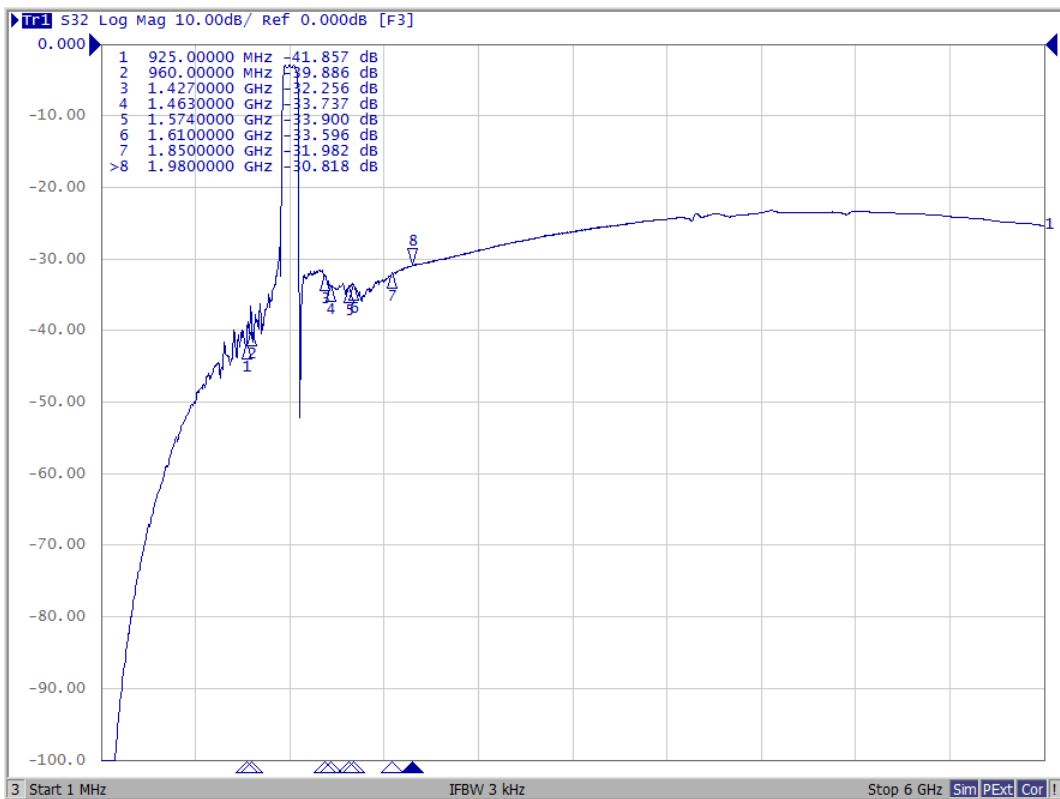

# L2+L5 Reflective Characteristic

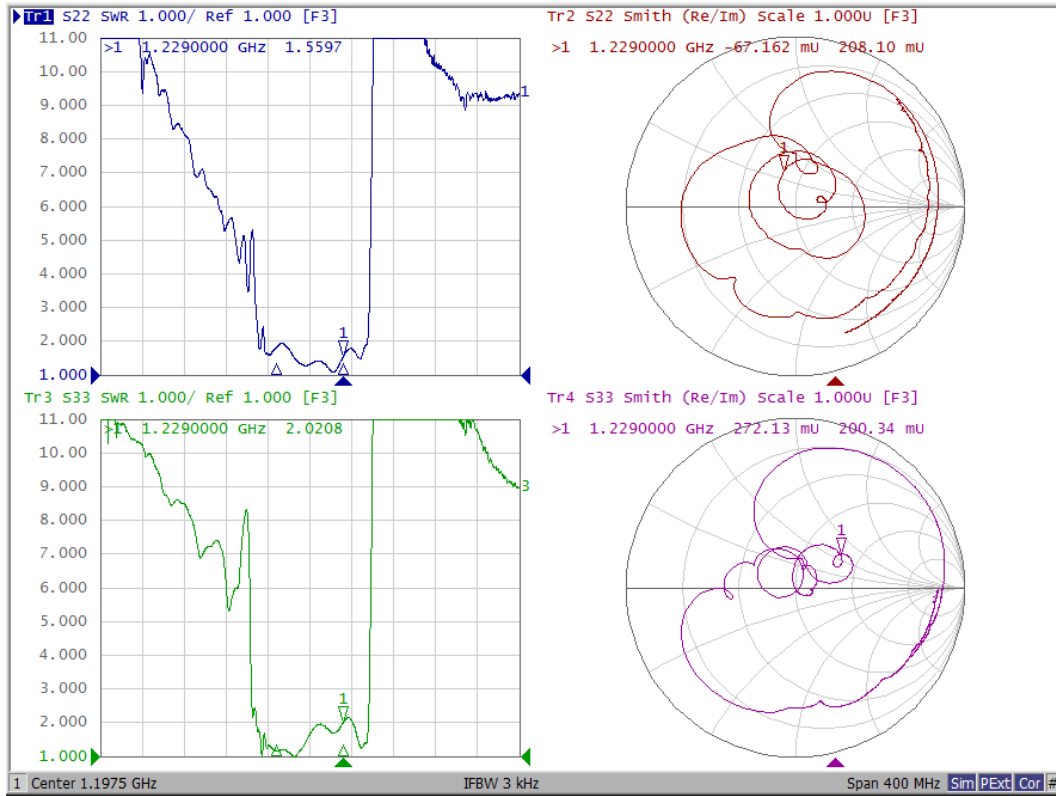

### L1 Pass Band

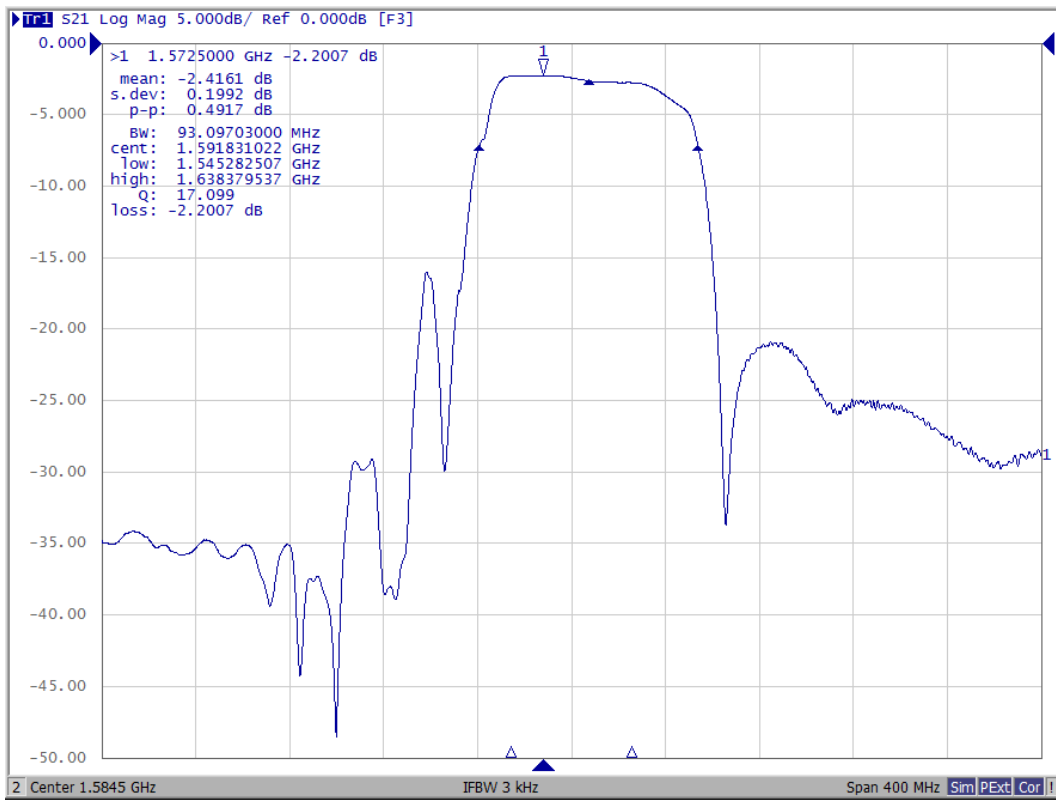

### L1 Full Range

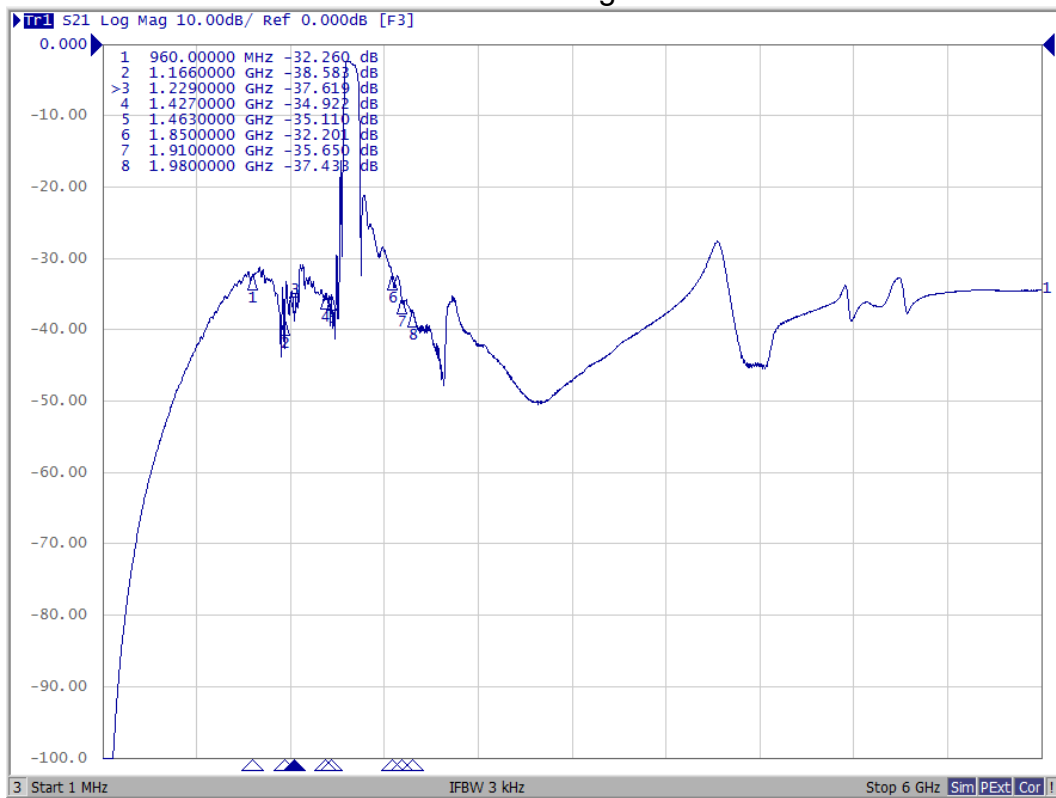

## L1 Reflective Characteristic

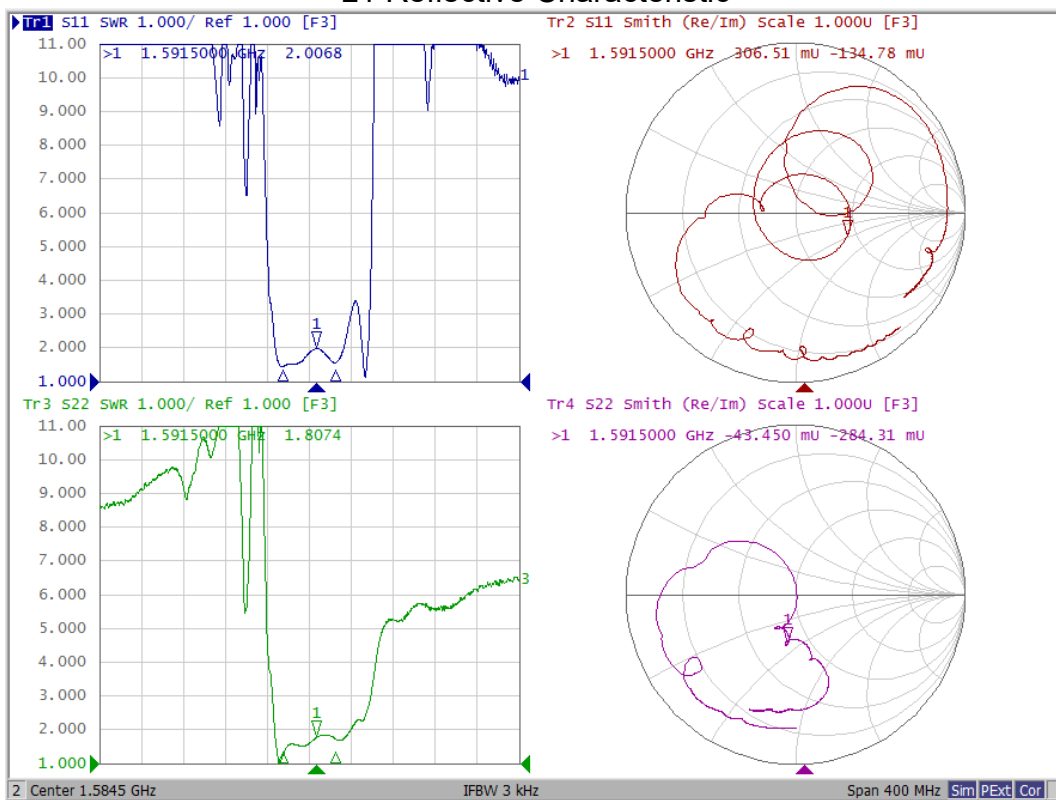

## Isolation

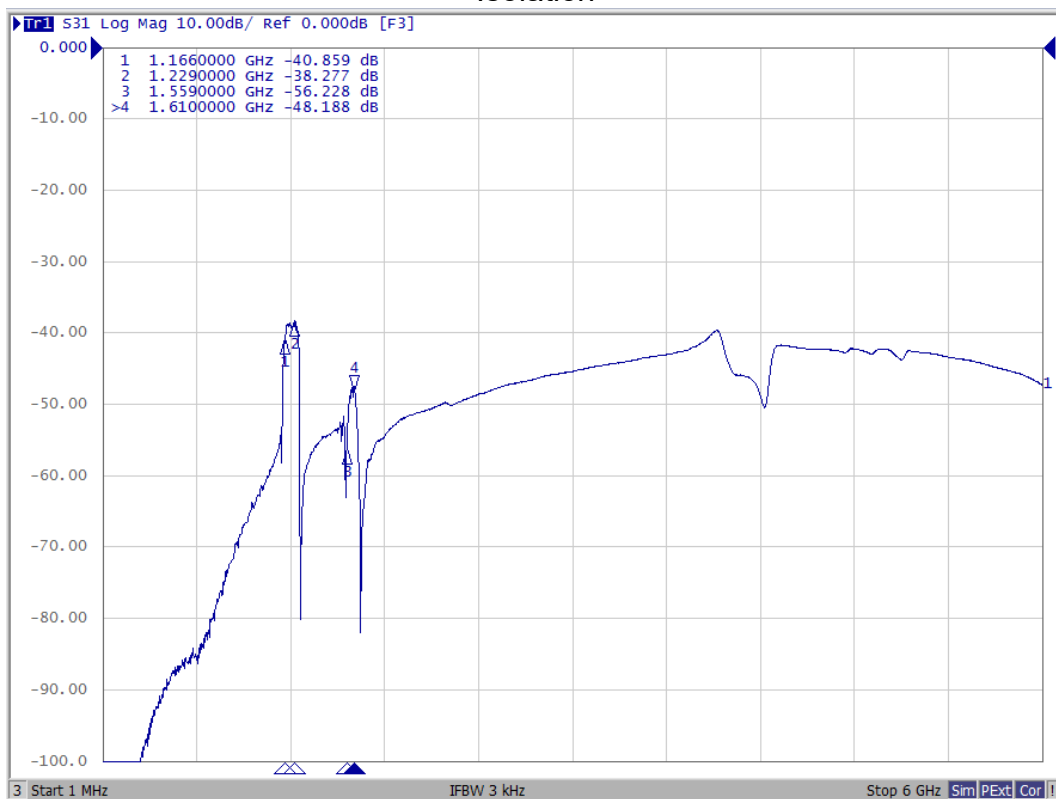



F. PCB FOOTPRINT:

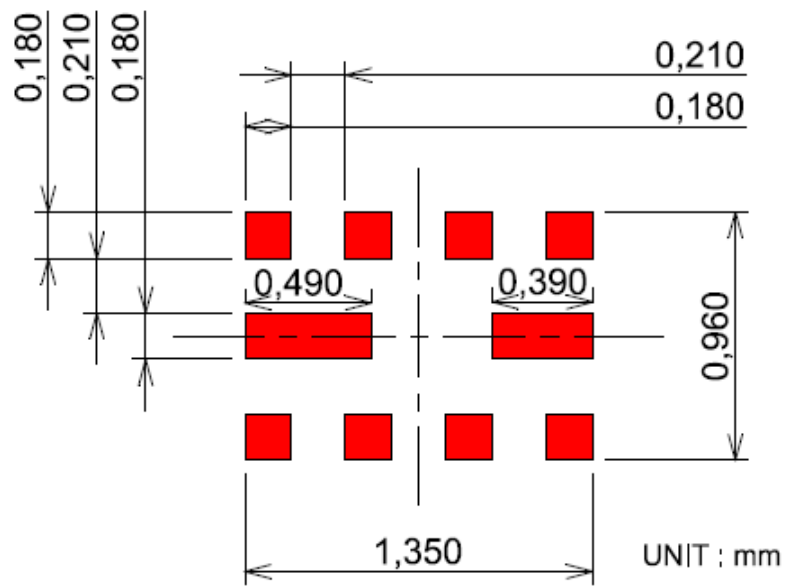

**G. PACKING:**

Reel Count: 7" = 3000

**1. REEL DIMENSION**

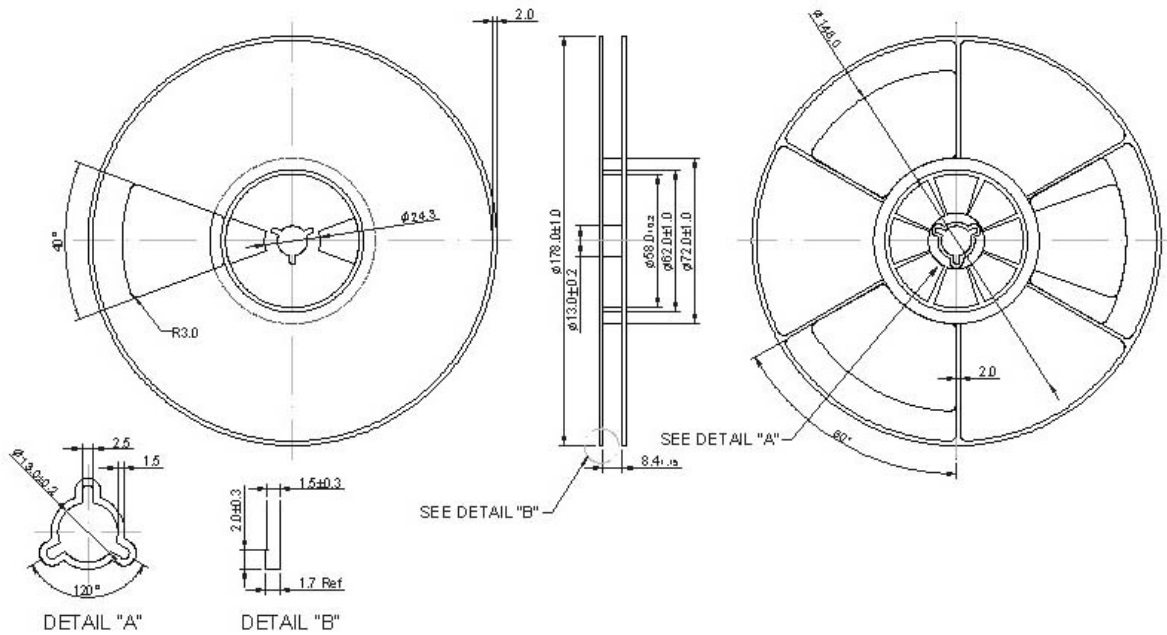

**2. TAPE DIMENSION**

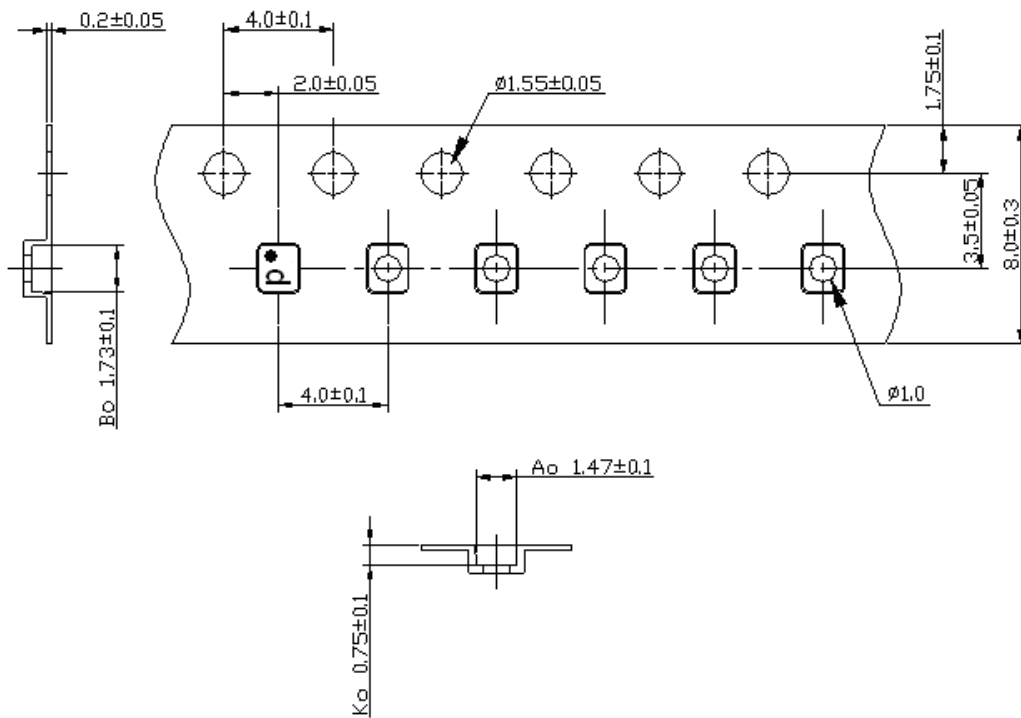

## H. RECOMMENDED REFLOW PROFILE :

1. Preheating shall be fixed at 150~180°C for 60~90 seconds.
2. Ascending time to preheating temperature 150°C shall be 30 seconds min.
3. Heating shall be fixed at 220°C for 50~80 seconds and at 260°C+0/-5°C peak (20~40sec).
4. Time: 2 times.

