

XTC7045G

24.000000 MHz
TCXO

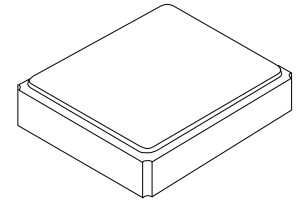

SM2520-4

Features:

- Ultra Miniature SMD Package
- Good Frequency Stability
- Good Phase Noise Response
- Moisture Sensitivity Level (MSL) : Level-1

Description and Applications:

Surface mount 2.5mmx2.0mm TCXO for use in wireless communications devices

Electrical Specifications:

XTC7045G	Specifications
Nominal Frequency, Fo	24.000000 MHz
Storage Temperature Range	-40°C to +85°C
Operating Temperature Range	-10°C to +75°C
Power Supply Voltage, Vcc	2.66~3.46V(normal 3.0V)
Output Voltage with Load 10pF//10KΩ, Vout	0.8 Vp-p min
Output Waveform	Clipped Sinewave
Output Load	10pF//10KΩ
Power Supply Current, Icc	2.0 mA max
Frequency Tolerance as Received Ref. to Nominal Frequency	+/- 0.5 ppm max @ 25°C +/- 3°C
Frequency Deviation after 2 x Reflow Ref. to pre-reflow Freq.	+/- 1.0 ppm max @ 25°C +/- 3°C
Frequency Stability	
a. Vs. Temperature (-10~75°C)	+/- 1.0 ppm reference to the 25°C
b. Vs. Load varied 10pF//10KΩ+/-5%	+/- 0.2 ppm
c. Vs. Supply Voltage varied Vcc+/-5%	+/- 0.2 ppm
Frequency slope (Minimum of one measurement every 2°C)	+/- 0.1 ppm/°C @ -10°C~+75°C
Duty Cycle	45~55%
Start Up Time (90% of final RF level in Vp-p)	2.0 msec max.

Static temperature hysteresis	+/-0.6 ppm max
Aging	+/-1.0 ppm/year @25°C
Harmonics	-8.0 dBc max
SSB Phase Noise(@1KHz Carrier Offset)	-132 dBc/Hz typ



CAUTION: Electrostatic Sensitive Device. Observe precautions for handling.

NOTES:

1. The design, manufacturing process, and specifications of this device are subject to change.
2. US or International patents may apply.
3. RoHS compliant from the first date of manufacture.

Mechanical Dimensions (mm):

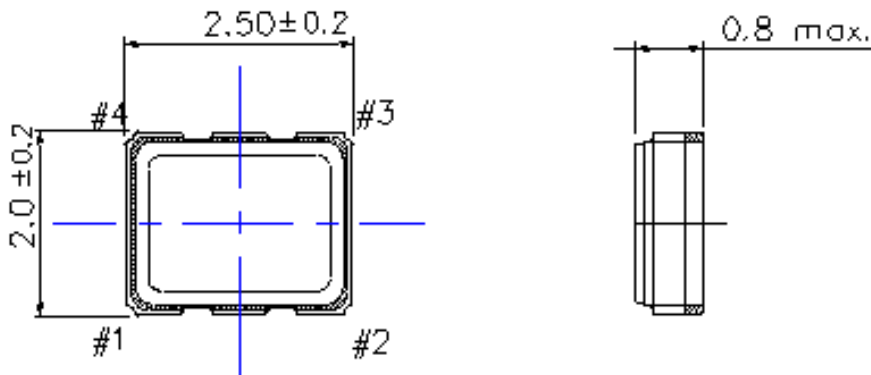

Unit : mm

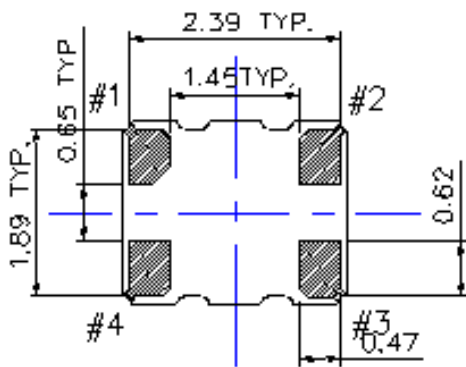

Pin Out for TCXD	
Pin#	Pin Connections
1	Ground Recommended
2	Ground
3	Output
4	Vcc

Recommended Land Pattern: (unit: mm)

Reference Land Pattern

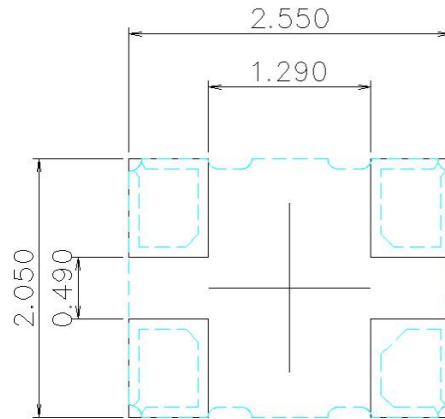

Marking:

Y = Year, W = Week

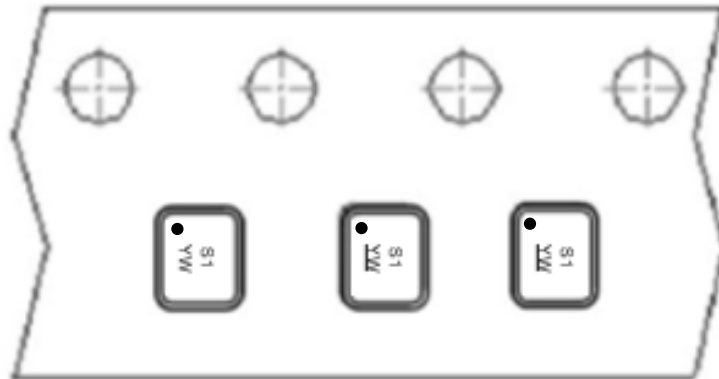
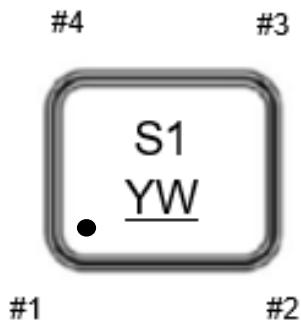

Recommended Circuit

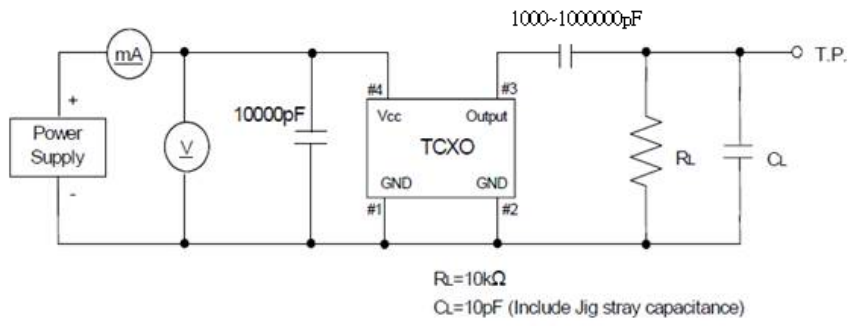

Reel Dimension

Reel Count: 7" = 3000

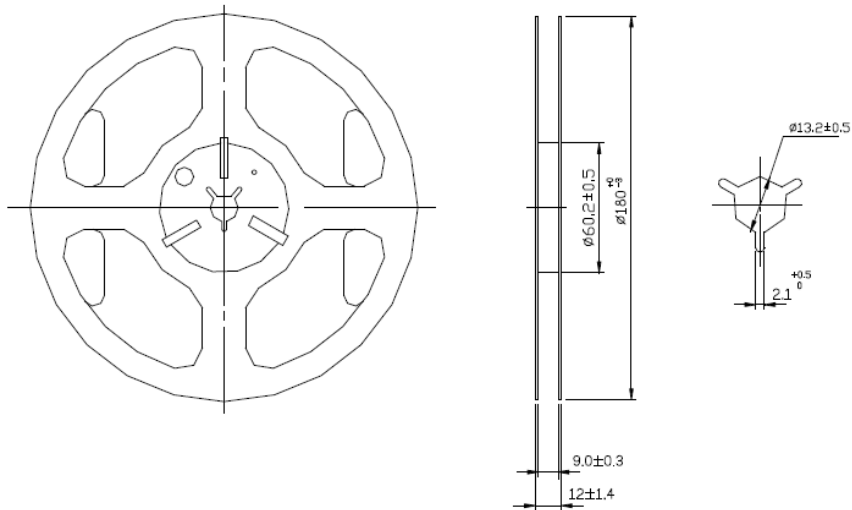

Tape Dimension

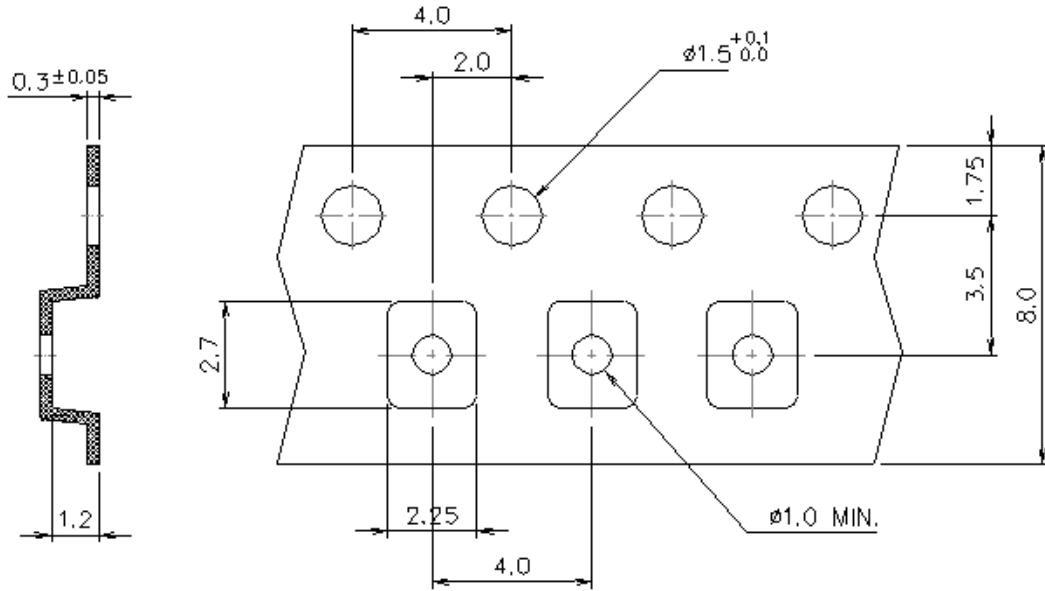

Packing Quantity/Packing:

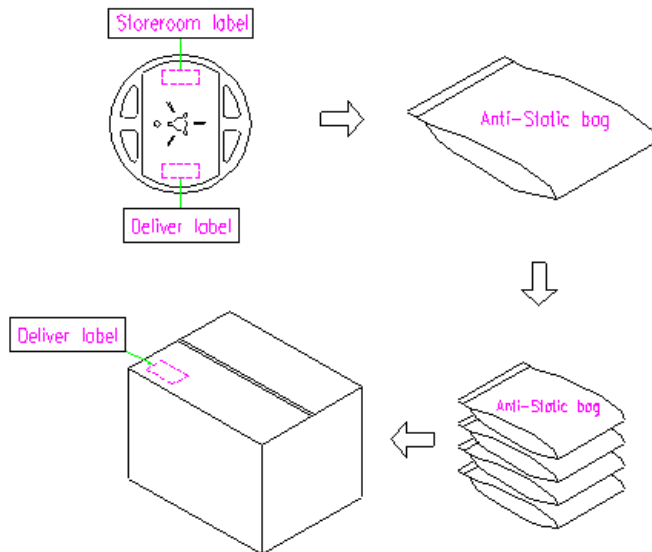

Reflow Profile:

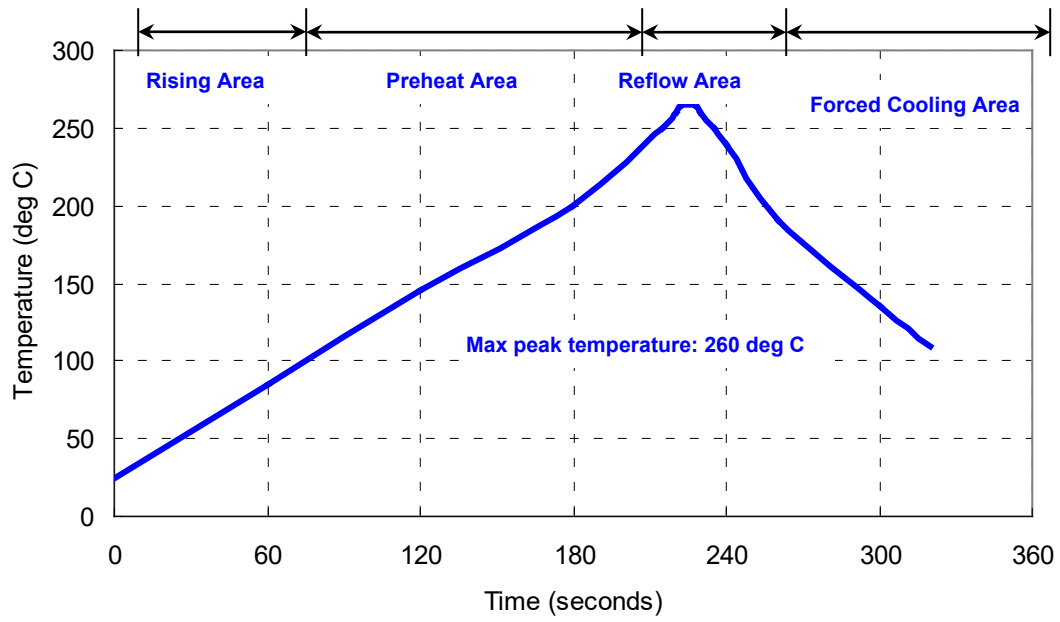

Notes of the Usage:

1. Touch the solder iron at 260+/-5 deg C onto the leads for 10+/-2 sec max or touch the solder at 350+/-5 deg C onto the leads for 3+/-0.5 sec.
2. In the customer's reflow process, if it will remain some mechanical stress at the soldering terminals, also make some cracks on the soldering termination. Some cracks will cause open or short circuit and cause of thermal increasing or smoking. Don't make any excess mechanical stress to soldering points.
3. In case of giving a heavy shock to the products, it may make an open or short circuit and cause of thermal increasing and smoking. To avoid heavy shock impact applying to products is strictly required.
4. Ultrasonic cleaning should be avoided to prevent damage to the crystal.
5. Do Not Use Ultrasonic-Wave Soldering or Wave Solder with Package Immersed in Solder.

Notes of the Storage:

1. To keep products under the condition at the room temperature (-5~35 deg C) with normal humidity (45~75%). Absorption of moisture and dewdrop may make inferiority of characteristics and a short circuit.
2. Oxidization of terminals shall make the solderability more inferior. Dusts and corrosive gas will make a cause of the open or short circuit. Keep it in the clean place where is not in dusty and no corrosive gas.
3. Use the anti-static material to the storage package.
4. Don't put any excess weight to the TCXO in the storage process.
5. Don't move the product from the cold place to the hot place in the short time, otherwise it may make some dew-drop, then a short circuit may happen in case.
6. Storage periods should be maximum 6 months under condition of above item 1 after delivery from the factory.
7. Once open the bag, there is possibility of electrical characteristics deterioration due to absorption of moisture. So, please use parts within 7 days after opening the bag.
8. If you have to keep parts without using after opening the bag, please put the drying agent in the bag, fold the bag and keep it in the place where temperature and humidity are controlled (nitrogen atmosphere box etc.)