

百盛新纪元半导体
 电话：13534212799
 QQ：2851339680

USB Type-C and PD Charging Controller

Description

The FP6606C is a simplified USB Power Delivery 3.0 protocol controller. It also integrated functions for HiSilicon Fast Charging Protocol (FCP) and Qualcomm Quick Charge 2.0/3.0.

The FP6606C monitors the CC pin to detect a USB Type-C attach/detach. It is capable providing output voltage of 5V to 20V. The FP6606C implements VBUS detection and discharge for the implementation of compliant connection ports. The protection features include over-voltage (D+/D-, CC1/CC2).

Pin Assignments

SP Package (SOP-8 Exposed Pad)

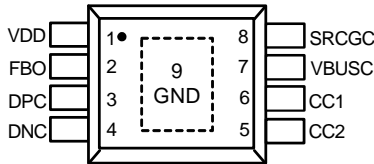

P5 CPC-16L Package

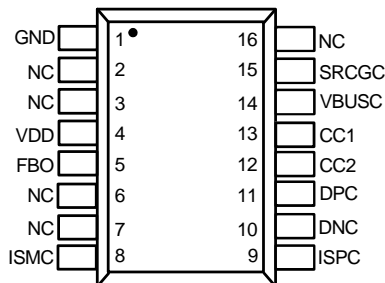

Features

- VDD Supply Voltage: 3.2V to 6.8V
- Supports USB Type-C and USB PD 3.0 (simplified)
 - 5V to 20V VBUS Source Only
 - CC1/CC2 Source Terminator 3A
- Supports HiSilicon Fast Charging Protocol (FCP)
- Supports Qualcomm® Quick Charge™ 2.0/3.0 Class A
- Automatically Selects FCP and QC2.0/3.0 Protocols
- VBUSC Discharge Function
- SOP-8 Exposed Pad and CPC-16L Packages

Applications

- Wall-Adapter
- Car Charger
- Power Strip
- USB Power Output Port

Ordering Information

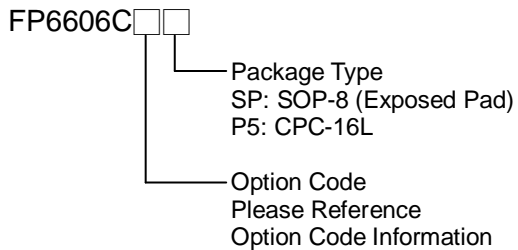

Option Code Information (USB PD)

Option Code	5V	9V	12V	15V	20V	Capability	Package
A	3A	2A	1.5A	-	-	18W	SP
L	3A	3A	-	2A	1.5A	30W	P5
M	3A	3A	-	3A	2.25A	45W	P5

Typical Application Circuit

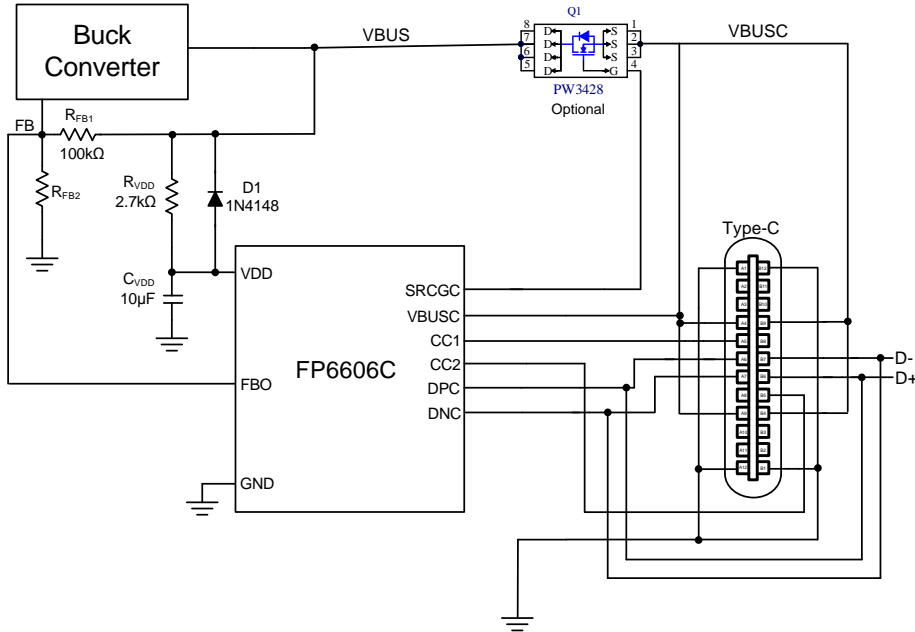
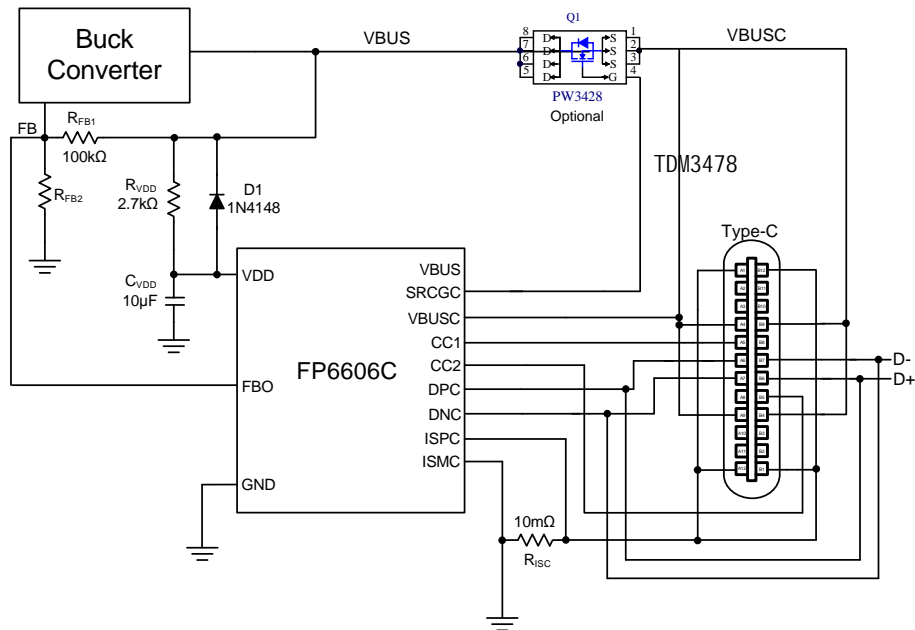
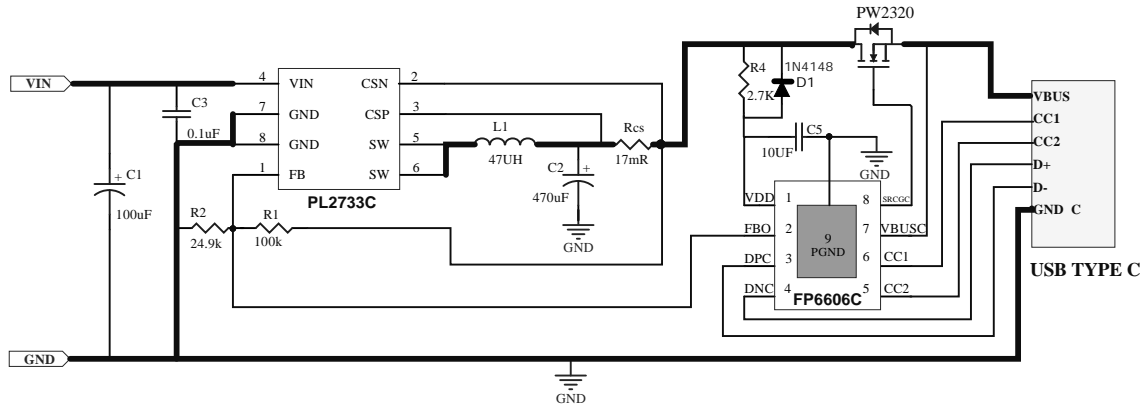

Figure1. SOP-8 Exposed Pad Typical Application Schematic



Q1 MOS 选型推荐	VDS	ID	RDS (ON)	封装	VGS	适用于 PD 输出功率
PW3400A	30V	5.8A	<28mΩ	SOT23-3	±12V	18W 至 20W
PW2320	20V	8A	<12mΩ	SOT23-3	±12V	18W 至 20W
PW3428	30V	28A	<15mΩ	DFN3*3-8	±20V	18W 至 45W
PW3467	30V	67A	<5mΩ	DFN3*3-8	±20V	18W 至 60W
PW3475	40V	75A	<6mΩ	DFN3*3-8	±20V	18W 至 60W

(USB TYPE C) PD3.0 /QC3.0/QC2.0 快速充电典型方案电路:



Functional Pin Description

Pin Name	Pin No.		Pin Function
	SOP-8	CPC-16L	
VDD	1	4	Supply input voltage pin.
FBO	2	5	Output voltage control pin. Current sink\source function for FB node.
DPC	3	11	USB D+ data line of Type-C.
DNC	4	10	USB D- data line of Type-C.
CC2	5	12	USB Type-C Configuration channel signal 2.
CC1	6	13	USB Type-C Configuration channel signal 1.
VBUSC	7	14	VBUS voltage discharge function for Type-C connector side.
SRCGC	8	15	N-MOSFET gate node control pin.
GND	9	1	Ground pin. The exposed pad must be connected to GND and well solder to a large PCB copper area for maximum power dissipation.
ISMC	-	8	Negative input of current sense amplifier of USB Type-C. Connect to the current sense resistor on the VBUS power path.
ISPC	-	9	Positive input of current sense amplifier of USB Type-C. Connect to the current sense resistor on the VBUS power path.
-	-	2	NC
-	-	3	NC
-	-	6	NC
-	-	7	NC
-	-	16	NC

Absolute Maximum Ratings ^(Note 1)

- Input Supply Voltage VDD ----- -0.3V to +7V
- DPC, DNC ----- -0.3V to +24V
- CC1, CC2 ----- -0.3V to +24V
- SRCGC, VBUSC ----- -0.3V to +35V
- Maximum Junction Temperature (T_J) ----- +150°C
- Storage Temperature (T_S) ----- -65°C to +150°C
- Lead Temperature (Soldering, 10sec.) ----- +260°C
- Package Thermal Resistance, (θ_{JA}) ^(Note 2)
 - SOP-8 (Exposed Pad) ----- 60°C/W
 - CPC-16L ----- TBD
- Package Thermal Resistance, (θ_{JC})
 - SOP-8 (Exposed Pad) ----- 15°C/W
 - CPC-16L ----- TBD

Note 1: Stresses beyond this listed under “Absolute Maximum Ratings” may cause permanent damage to the device.

Note 2: θ_{JA} is measured at 25°C ambient with the component mounted on a high effective thermal conductivity test board of JEDEC-51-7.

Recommended Operating Conditions

- Input supply voltage (VDD) ----- +3.2V to +6.8V
- Operating temperature range (T_A) ----- -40°C to +125°C
- Junction temperature (T_J) ----- -40°C to +125°C

Electrical Characteristics

(V_{DD}=5V, T_A=25°C and the recommended supply voltage range, unless otherwise specified.)

Parameter	Symbol	Conditions	Min	Typ	Max	Unit
Input Power						
VDD Input Voltage Range	V _{DD}		3.2		6.8	V
Input UVLO Threshold	V _{DD_UVLO}	V _{DD} Rising		3.3		V
	V _{DD_HYS}	V _{DD} Falling		2.6		V
VDD Supply Current	I _{DD_SUP}	V _{DD} =5V, Nothing Attach	20	33	45	μA
VDD Shunt Voltage	V _{DD_SHDN}		5.9	6.4	6.8	V
N-MOSFET Gate Driver						
SRCGC Sourcing Current		V _{DD} =4V, 0V ≤ V _{SRCGC} - V _{BUSC} ≤ 6V	4.5		1.8	μA
Sourcing Voltage (ON) between SRCGC and VBUS		V _{DD} =3.2V to 6.8V	5		15	V
VBUSC						
VBUSC Bleed Discharge Resistance	R _{CBLEED}		8	10	12.5	kΩ
VBUSC Discharge Resistance	R _{CDIS}			400		Ω
USB Type-C						
DPDN OV Threshold ^(Note 3)	V _{DPDNOV}	In QC Mode		4		V
CCOV Rising ^(Note 3)	V _{CCOV-rising}			1.04*V _{DD}		V
CCOV Falling ^(Note 3)	V _{CCOV-falling}			V _{DD}		V
High Voltage Dedicated Charging Port (HVDCP)						
Data Detect Voltage	V _{DAT(REF)}		0.25	0.325	0.4	V
Output Voltage Selection Reference	V _{SEL_REF}		1.8	2.0	2.2	V
DPC High Glitch Filter Time	T _{GLITCH(BC)-DPA-H}		1000	1250	1500	ms
DNC Low Glitch Filter Time	T _{GLITCH(BC)-DNC-L}			1		ms
Output Voltage Glitch Filter Time	T _{GLITCH(V) CHANGE}		20	40	60	ms
DNC Pull-Down Resistance	R _{DNC(DWN)}			20		kΩ
Continuous Mode Glitch Filter Time	T _{GLITCH-CONT -CHANGE}		100		200	μs

Electrical Characteristics (Continued)

(VDD=5V, TA=25°C and the recommended supply voltage range, unless otherwise specified.)

Parameter	Symbol	Conditions	Min	Typ	Max	Unit
DPC Leakage Resistance	R _{DAT-LKG}	V _{DD} =3.2 to 6.4V VDPA=0.6-3.6V Switch SW1=Off	300	500	800	kΩ
Switch SW1 On-Resistance	R _{DS_ON,N1}	V _{DD} =5V, SW1= 200μA			40	Ω
UP/Down Current Step	I _{UP, IDOWN}	I _{UP} =0μA (5V), 40μA (9V) 70μA (12V), 100μA (15V) 150μA (20V) I _{DOWN} =14μA (3.6V)		2		μA
DPC Charging Mode						
DPC _{0.48V} / DNC _{0.48V} Line Output Voltage			0.44	0.48	0.52	V
DPC _{0.48V} / DNC _{0.48V} Line Output Impedance				900		kΩ
Apple Mode						
DPC _{2.7V} / DNC _{2.7V} Line Output Voltage			2.57	2.7	2.84	V
DPC _{2.7V} / DNC _{2.7V} Line Output Impedance				33.6		kΩ
DNC SECTION (FCP)						
DNC FCP Tx Valid Output High	V _{TX-VOH}		2.55		3.6	V
DNC FCP Tx Valid Output Low	V _{TX-VOL}				0.3	V
DNC FCP Rx Valid Output High	V _{RX-VIH}		1.4		3.6	V
DNC FCP Rx Valid Output Low	V _{RX-VIL}				1.0	V
DNC Output Pull-Low Resistance	R _{PD}		400	500	600	Ω
Unit Interval for FCP PHY Communication	UI	F _{CLK} =125kHz	144	160	180	μs
Over-Circuit Protection (CPC-16L Only)						
Over-Current Threshold	OCP		3.4	3.7	4.0	A

Note 3: Guarantee by design.

Function Description

Data Line Interface (D+/D-)

FP6606C supports QC 2.0/3.0/FCP and SCP protocol on the D+/D- data line. The related registers are assigned to the vendor define registers. When the FP6606C is configured as QC 2.0/3.0/FCP mode, both D+ and D- pin are applied to 2.7V. If sink device has the function of QC 2.0/3.0/FCP, D+ pin will be forced between 0.325V and 2V. In the meanwhile, D+ pin will be automatically connected to D- pin by FP6606C and this process is called the short mode for USB BC1.2 specification. If D+ is continuously applied to the voltage between 0.325V and 2V for 1.25 seconds, the FP6606C will enter QC 2.0/3.0/FCP operation mode. The QC 2.0/3.0 could be classed as the following table.

D+	D-	Output Voltage
0.6V	0.6V	12V
3.3V	0.6V	9V
0.6V	3.3V	Continuous mode
0.6V	High-Z	5V (Default)

When the voltage of D+ pin and D- pin simultaneously satisfy these two inequalities $V_{DAT}(REF) < D+ < V_{SEL_REF}$ and $D- > V_{SEL_REF}$, the FP6606CM would enter continuous mode.

In the continuous mode, each voltage pulse on D- pin generated by sink device is between 3V and 1V. At the same time, the low level of pulse should be keep at least 200us (default). If the specified conditions are satisfied, the FBO pin will source 2μA (default) per pulse. The maximum source current is 70μA for output voltage 12V.

If the sink device doesn't support QC 2.0/3.0, the FP6606C will remain default output voltage 5V for safe operation. On the other hand, when USB cable is removed, the voltage of D+ pin is therefore lower than $V_{DAT}(REF)$ and the output default voltage 5V is also applied.

Shunt Regulator

The VDD of FP6606C is supplied by the wide output voltage through the external resistor RVDD. The internal Zener-Diode is utilized to clamp the VDD at 6.4V. The recommended value of RVDD and CVDD are 2.7kΩ and 10μF, respectively.

VBUS Control

The FP6606C is a controller so that it must be combined with power stage. The FBO pin of FP6606C must be connected to the feedback node of power stage. The VBUS control of FP6606C is implemented by sourcing/sinking current from FBO pin.

Over-Current Protection (CPC-16L Only)

The FP6606C could detect the current value with current sense resistance ($R_{isc}=10m\Omega$) to support the Over-Current Protection(OCP). If out current over 3.7A, FP6606C will enable OCP function, then turn off N-MOSFET through SRCGC pin. Protection states is hiccup and auto recovery.

VBUSC Discharge

When Type-C device plug out connector, N-MOSFET will be turned off. At this moment in time, FP6606C execute VBUSC discharge function to avoid Type-C connector existing remaining voltage. If Type-C connector exist remaining voltage, when device plug in, it maybe damage device.

Data Line Protection

When DPC/DNC pin is touched by the external power in abnormal situation, the D+/D- pin of both sink device and source device may be damaged. In order to protect the DPC/DNC pin of the devices from damage in abnormal situation, the FP6606C will return the output voltage to default output voltage 5V when the voltage of DPC/DNC pin is higher than 4V.

Configuration Channel Protection

When CC1/CC2 pin is touched by the external power in abnormal situation, the CC1/CC2 pin of both sink device and source device may be damaged. In order to protect the CC1/CC2 pin of the devices from damage in abnormal situation, the FP6606C will return the output voltage to default output voltage 5V.

Outline Information

SOP-8 (Exposed Pad) Package (Unit: mm)

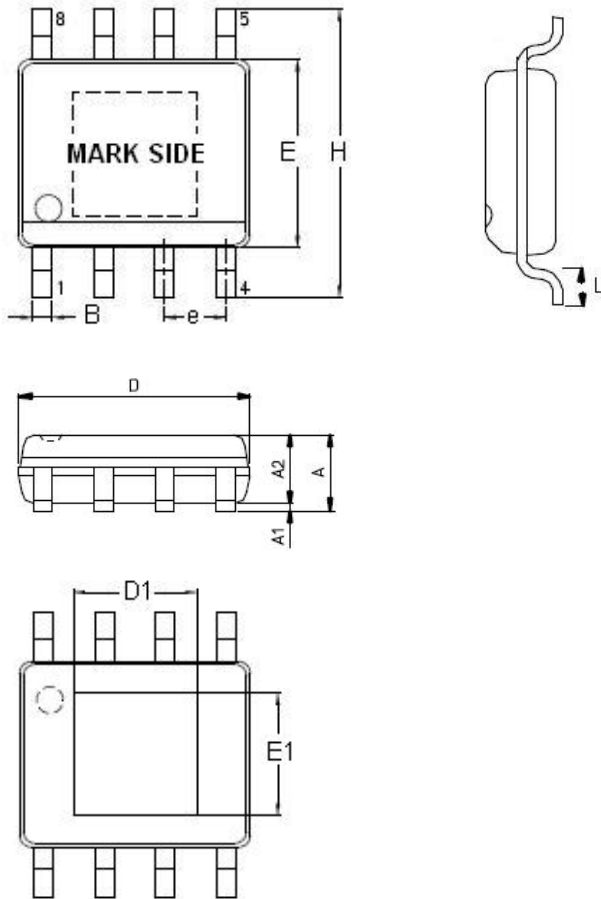

SYMBOLS UNIT	DIMENSION IN MILLIMETER	
	MIN	MAX
A	1.25	1.70
A1	0.00	0.15
A2	1.25	1.55
B	0.31	0.51
D	4.80	5.00
D1	3.04	3.50
E	3.80	4.00
E1	2.15	2.41
e	1.20	1.34
H	5.80	6.20
L	0.40	1.27

Note: Followed From JEDEC MO-012-E.

Carrier Dimensions

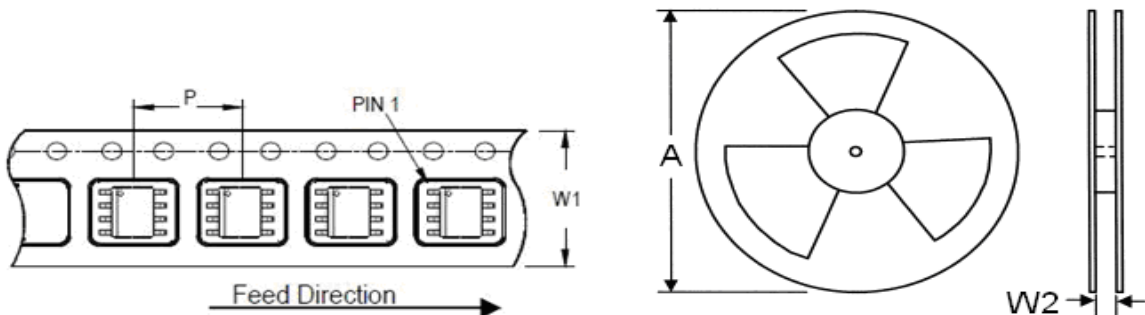

Tape Size (W1) mm	Pocket Pitch (P) mm	Reel Size (A)		Reel Width (W2) mm	Empty Cavity Length mm	Units per Reel
		in	mm			
12	8	13	330	12.4	400~1000	2,500

Outline Information (Continued)

CPC-16L Package (Unit: mm)

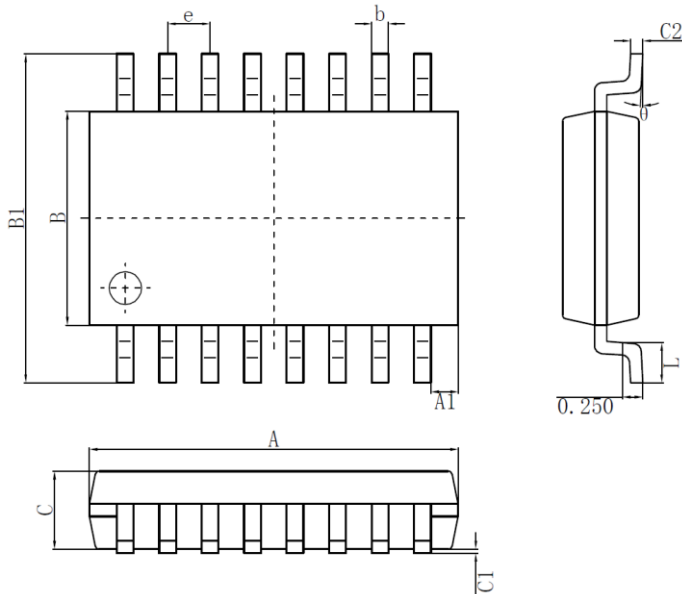

SYMBOLS UNIT	DIMENSION IN MILLIMETER	
	MIN	MAX
A	4.50	4.70
A1	0.29	0.39
B	2.50	2.70
B1	3.85	4.15
C	0.85	1.05
C1	0.00	0.15
C2	0.15	0.18
e	0.53(BSC)	
b	0.16	0.26
L	0.40	0.60

Carrier Dimensions

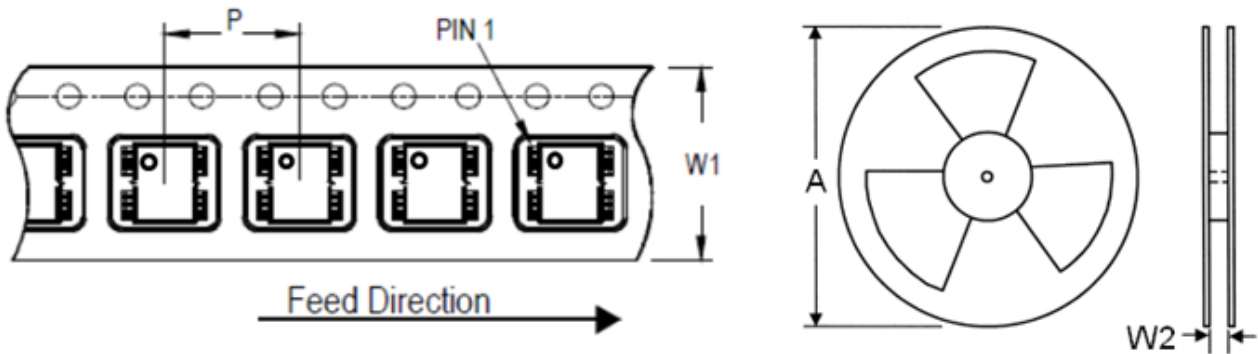

Tape Size (W1) mm	Pocket Pitch (P) mm	Reel Size (A)		Reel Width (W2) mm	Empty Cavity Length mm	Units per Reel
		in	mm			
12	8	15	380	12.5	300~1000	7,500

Life Support Policy

Fitipower's products are not authorized for use as critical components in life support devices or other medical systems.