

TPS3700-Q1 Window Comparator for Over- and Undervoltage Detection

1 Features

- Qualified for Automotive Applications
- AEC-Q100 Qualified With the Following Results:
 - Device Temperature Grade 1: -40°C to 125°C Ambient Operating Temperature Range
 - Device HBM ESD Classification Level H2
 - Device CDM ESD Classification Level C6
- Wide Supply Voltage Range: 1.8 to 18 V
- Adjustable Threshold: Down to 400 mV
- Open-Drain Outputs for Overvoltage and Undervoltage Detection
- Low Quiescent Current: 5.5 μA (typ)
- High Threshold Accuracy:
 - 1% Over Temperature
 - 0.25% (typ)
- Internal Hysteresis: 5.5 mV (typ)
- Available in ThinSOT23-6 and WSON Packages

2 Applications

- Automotive Safety Applications
- Body Electronics
- Infotainment
- Low Battery Detection
- Power Sequencing
- Industrial Control Systems
- FPGA and ASIC Applications
- Microcontroller and DSP Applications

4 Simplified Schematic

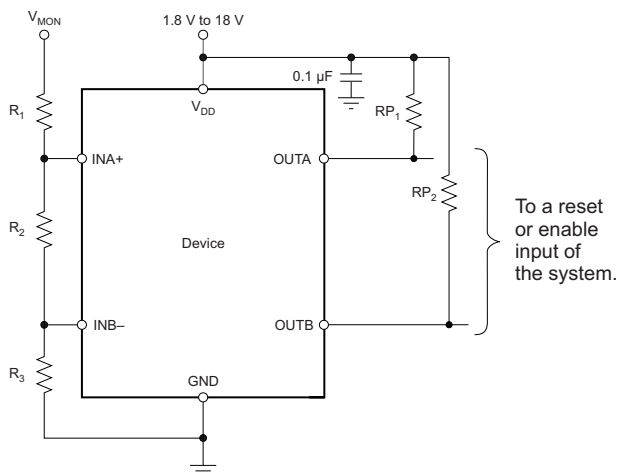

3 Description

The TPS3700-Q1 wide-supply voltage window comparator operates over a 1.8-V to 18-V range. The device has two high-accuracy comparators with an internal 400-mV reference and two open-drain outputs rated to 18 V for overvoltage and undervoltage detection. The TPS3700-Q1 device can be used as a window comparator or as two independent voltage monitors; the monitored voltage can be set with the use of external resistors.

The OUTA terminal is driven low when the voltage at the INA+ terminal drops below $(V_{IT+} - V_{hys})$, and goes high when the voltage returns above the respective threshold (V_{IT+}) . The OUTB terminal is driven low when the voltage at the INB- terminal rises above V_{IT+} , and goes high when the voltage drops below the respective threshold $(V_{IT+} - V_{hys})$. Both comparators in the TPS3700-Q1 device include built-in hysteresis for filtering to reject brief glitches, thereby ensuring stable output operation without false triggering.

The TPS3700-Q1 device is available in a ThinSOT23-6 package and is specified over the junction temperature range of -40°C to 125°C .

Device Information(1)

ORDER NUMBER	PACKAGE	BODY SIZE
TPS3700QDDCRQ1	SOT23 (6)	2.90 mm x 1.60 mm
	WSON (6)	1.50 mm x 1.50 mm

(1) For all available packages, see the orderable addendum at the end of the data sheet.

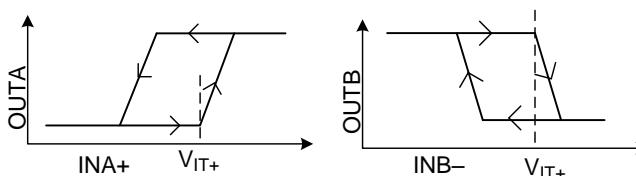

Table of Contents

1 Features	1	8.2 Functional Block Diagram	9
2 Applications	1	8.3 Feature Description	9
3 Description	1	8.4 Device Functional Modes	11
4 Simplified Schematic	1	9 Application and Implementation	12
5 Revision History	2	9.1 Application Information	12
6 Pin Configuration and Functions	3	9.2 Typical Application	15
7 Specifications	4	10 Power Supply Recommendations	16
7.1 Absolute Maximum Ratings	4	11 Layout	17
7.2 Handling Ratings	4	11.1 Layout Guidelines	17
7.3 Recommended Operating Conditions	4	11.2 Layout Example	17
7.4 Thermal Information	4	12 Device and Documentation Support	18
7.5 Electrical Characteristics	5	12.1 Documentation Support	18
7.6 Timing Requirements	6	12.2 Trademarks	18
7.7 Switching Characteristics	6	12.3 Electrostatic Discharge Caution	18
7.8 Typical Characteristics	7	12.4 Glossary	18
8 Detailed Description	9	13 Mechanical, Packaging, and Orderable Information	18
8.1 Overview	9		

5 Revision History

Changes from Revision A (April 2014) to Revision B

Page

- Added WSON Package to Device Information Table
- Added WSON Package to Pin Configuration and Function table

Changes from Original (March 2014) to Revision A

Page

- Changed device status from *Product Preview* to *Production Data*

6 Pin Configuration and Functions

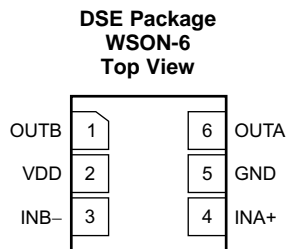
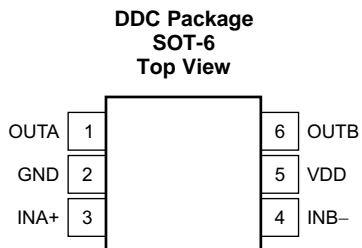

Pin Functions

NAME	PIN		I/O	DESCRIPTION
	DDC	DSE		
GND	2	5	—	Ground
INA+	3	4	I	This pin is connected to the voltage to be monitored with the use of an external resistor divider. When the voltage at this terminal drops below the threshold voltage ($V_{IT+} - V_{HYS}$), OUTA is driven low.
INB-	4	3	I	This pin is connected to the voltage to be monitored with the use of an external resistor divider. When the voltage at this terminal exceeds the threshold voltage (V_{IT+}), OUTB is driven low.
OUTA	1	6	O	INA+ comparator open-drain output. OUTA is driven low when the voltage at this comparator is below ($V_{IT+} - V_{HYS}$). The output goes high when the sense voltage returns above the respective threshold (V_{IT+}).
OUTB	6	1	O	INB- comparator open-drain output. OUTB is driven low when the voltage at this comparator exceeds V_{IT+} . The output goes high when the sense voltage returns below the respective threshold ($V_{IT+} - V_{HYS}$).
VDD	5	2	I	Supply voltage input. Connect a 1.8-V to 18-V supply to VDD to power the device. Good analog design practice is to place a 0.1- μ F ceramic capacitor close to this pin.

7 Specifications

7.1 Absolute Maximum Ratings

Over operating temperature range (unless otherwise noted)⁽¹⁾

		MIN	MAX	UNIT
Voltage ⁽²⁾	V _{DD}	-0.3	20	V
	OUTA, OUTB	-0.3	20	V
	INA+, INB-	-0.3	7	V
Current	Output terminal current		40	mA
Operating junction temperature, T _J		-40	125	°C

- (1) Stresses beyond those listed under *Absolute Maximum Ratings* may cause permanent damage to the device. These are stress ratings only, which do not imply functional operation of the device at these or any other conditions beyond those indicated under *Recommended Operating Conditions*. Exposure to absolute-maximum-rated conditions for extended periods may affect device reliability.
- (2) All voltages are with respect to network ground terminal.

7.2 Handling Ratings

		MIN	MAX	UNIT
T _{stg}	Storage temperature range	-65	150	°C
V _{ESD} ⁽¹⁾	Human body model (HBM) ESD stress voltage ⁽²⁾		2.5	kV
	Charge device model (CDM) ESD stress voltage ⁽³⁾		1	

- (1) Electrostatic discharge (ESD) to measure device sensitivity and immunity to damage caused by assembly line electrostatic discharges in to the device.
- (2) Level listed above is the passing level per ANSI, ESDA, and JEDEC JS-001. JEDEC document JEP155 states that 500-V HBM allows safe manufacturing with a standard ESD control process.
- (3) Level listed above is the passing level per EIA-JEDEC JESD22-C101. JEDEC document JEP157 states that 250-V CDM allows safe manufacturing with a standard ESD control process.

7.3 Recommended Operating Conditions

Over operating temperature range (unless otherwise noted)

		MIN	MAX	UNIT	
V _{DD}	Supply voltage	1.8	18	V	
V _I	Input voltage	INA+, INB-	0	6	V
V _O	Output voltage	OUTA, OUTB	0	18	V

7.4 Thermal Information

THERMAL METRIC ⁽¹⁾		DDC (6 TERMINALS)	UNIT
R _{θJA}	Junction-to-ambient thermal resistance	204.6	°C/W
R _{θJC(top)}	Junction-to-case (top) thermal resistance	50.5	
R _{θJB}	Junction-to-board thermal resistance	54.3	
ψ _{JT}	Junction-to-top characterization parameter	0.8	
ψ _{JB}	Junction-to-board characterization parameter	52.8	
R _{θJC(bot)}	Junction-to-case (bottom) thermal resistance	—	

- (1) For more information about traditional and new thermal metrics, see the *IC Package Thermal Metrics* application report, [SPRA953](http://www.ti.com/lit/an/spra953).

7.5 Electrical Characteristics

Over the operating temperature range of $T_J = -40^{\circ}\text{C}$ to 125°C , and $1.8\text{ V} < V_{DD} < 18\text{ V}$, unless otherwise noted. Typical values are at $T_J = 25^{\circ}\text{C}$ and $V_{DD} = 5\text{ V}$.

PARAMETER		TEST CONDITIONS	MIN	TYP	MAX	UNIT
V_{DD}	Supply voltage range		1.8		18	V
$V_{(POR)}$	Power-on reset voltage ⁽¹⁾	$V_{OLmax} = 0.2\text{ V}$, $I_{(OUTA/B)} = 15\text{ }\mu\text{A}$			0.8	V
V_{IT+}	Positive-going input threshold voltage	$V_{DD} = 1.8\text{ V}$	396	400	404	mV
		$V_{DD} = 18\text{ V}$	396	400	404	mV
V_{IT-}	Negative-going input threshold voltage	$V_{DD} = 1.8\text{ V}$	387	394.5	400	mV
		$V_{DD} = 18\text{ V}$	387	394.5	400	mV
V_{hys}	Hysteresis voltage ($hys = V_{IT+} - V_{IT-}$)			5.5	12	mV
$I_{(INA+)}$ $I_{(INB-)}$	Input current (at the INA+ or INB- terminal)	$V_{DD} = 1.8\text{ V}$ and 18 V , $V_I = 6.5\text{ V}$	-25	1	25	nA
		$V_{DD} = 1.8\text{ V}$ and 18 V , $V_I = 0.1\text{ V}$	-15	1	15	nA
V_{OL}	Low-level output voltage	$V_{DD} = 1.3\text{ V}$, $I_O = 0.4\text{ mA}$			250	mV
		$V_{DD} = 1.8\text{ V}$, $I_O = 3\text{ mA}$			250	mV
		$V_{DD} = 5\text{ V}$, $I_O = 5\text{ mA}$			250	mV
$I_{lkg(OD)}$	Open-drain output leakage-current	$V_{DD} = 1.8\text{ V}$ and 18 V , $V_O = V_{DD}$			300	nA
		$V_{DD} = 1.8\text{ V}$, $V_O = 18\text{ V}$			300	nA
I_{DD}	Supply current	$V_{DD} = 1.8\text{ V}$, no load		5.5	11	μA
		$V_{DD} = 5\text{ V}$		6	13	μA
		$V_{DD} = 12\text{ V}$		6	13	μA
		$V_{DD} = 18\text{ V}$		7	13	μA
	Startup delay ⁽²⁾			150		μs
UVLO	Undervoltage lockout ⁽³⁾	V_{DD} falling	1.3		1.7	V

(1) The lowest supply voltage (V_{DD}) at which output is active; $t_{r(VDD)} > 15\text{ }\mu\text{s/V}$. Below $V_{(POR)}$, the output cannot be determined.

(2) During power on, V_{DD} must exceed 1.8 V for at least $150\text{ }\mu\text{s}$ before the output is in a correct state.

(3) When V_{DD} falls below UVLO, OUTA is driven low and OUTB goes to high impedance. The outputs cannot be determined below $V_{(POR)}$.

7.6 Timing Requirements

Over operating temperature range (unless otherwise noted)

			MIN	TYP	MAX	UNIT
t_{PHL}	High-to-low propagation delay ⁽¹⁾	$V_{DD} = 5\text{ V}$, 10-mV input overdrive, $R_P = 10\text{ k}\Omega$, $V_{OH} = 0.9 \times V_{DD}$, $V_{OL} = 400\text{ mV}$ See Figure 1		18		μs
t_{PLH}	Low-to-high propagation delay ⁽¹⁾	$V_{DD} = 5\text{ V}$, 10-mV input overdrive, $R_P = 10\text{ k}\Omega$, $V_{OH} = 0.9 \times V_{DD}$, $V_{OL} = 400\text{ mV}$ See Figure 1		29		μs

(1) High-to-low and low-to-high refers to the transition at the input terminals (INA+ and INB-).

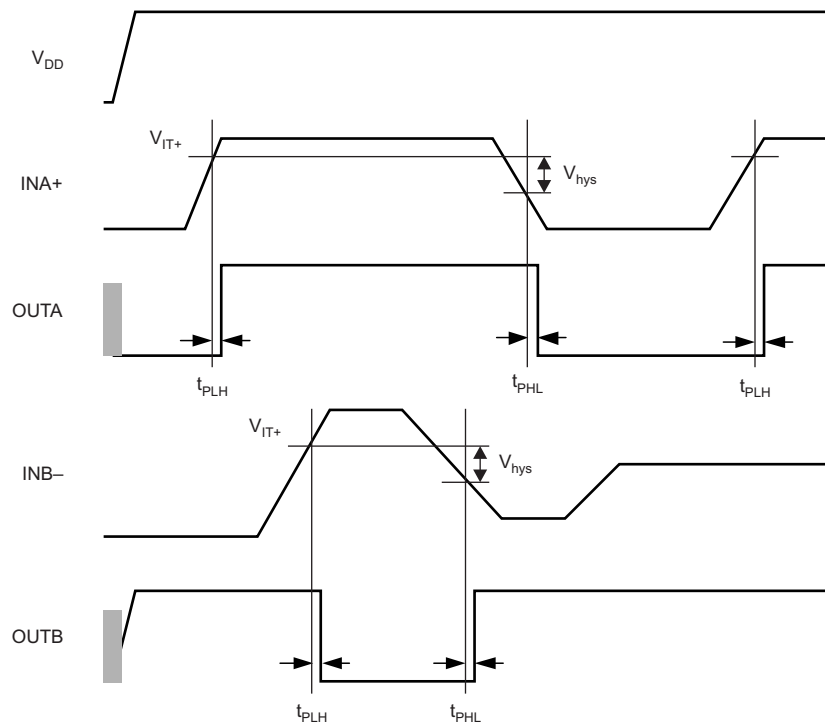

Figure 1. Timing Diagram

7.7 Switching Characteristics

Over operating temperature range (unless otherwise noted)

PARAMETER	TEST CONDITIONS	MIN	TYP	MAX	UNIT
t_r	Output rise time $V_{DD} = 5\text{ V}$, 10-mV input overdrive, $R_P = 10\text{ k}\Omega$, $V_O = (0.1\text{ to }0.9) \times V_{DD}$		2.2		μs
t_f	Output fall time $V_{DD} = 5\text{ V}$, 10-mV input overdrive, $R_P = 10\text{ k}\Omega$, $V_O = (0.1\text{ to }0.9) \times V_{DD}$		0.22		μs

7.8 Typical Characteristics

At $T_J = 25^\circ\text{C}$ and $V_{DD} = 5\text{ V}$, unless otherwise noted.

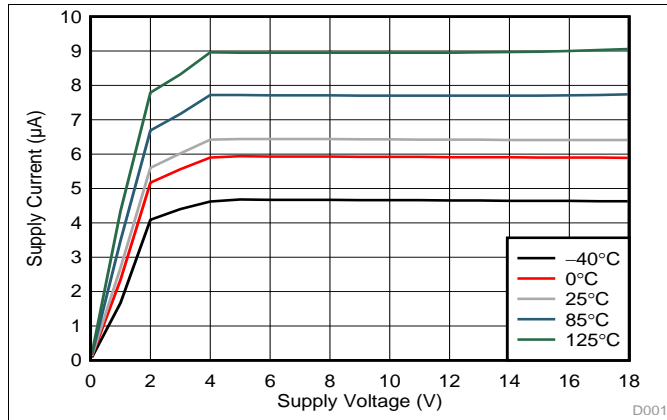

Figure 2. Supply Current (I_{DD}) vs Supply Voltage (V_{DD})

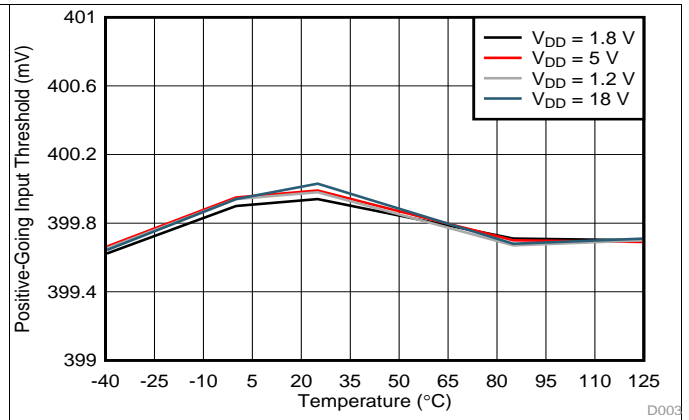

Figure 3. Rising Input Threshold Voltage (V_{IT+}) vs Temperature

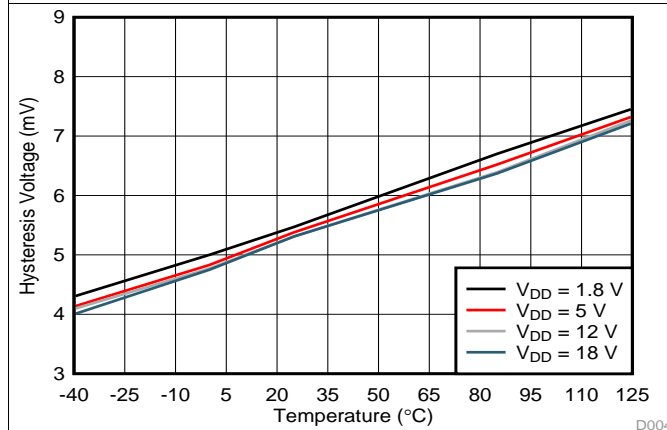

Figure 4. Hysteresis (V_{hys}) vs Temperature

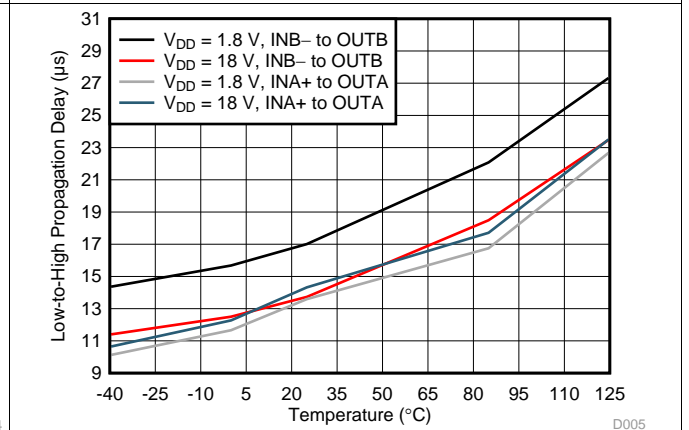

Figure 5. Propagation Delay vs Temperature (High-to-Low Transition at the Inputs)

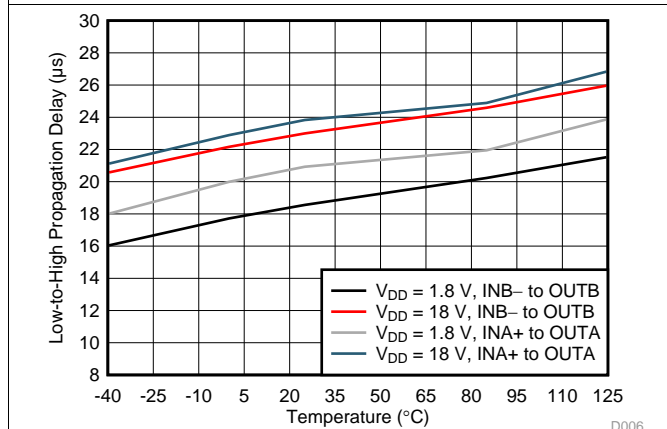

Figure 6. Propagation Delay vs Temperature (Low-to-High Transition at the Inputs)

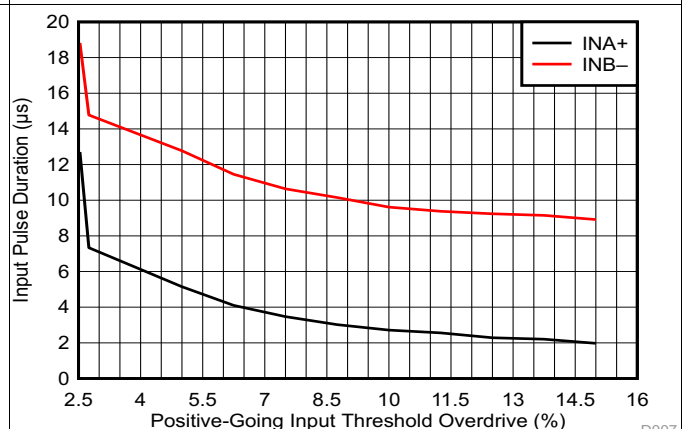

Figure 7. Minimum Pulse Width vs Threshold Overdrive Voltage

Typical Characteristics (continued)

At $T_J = 25^\circ\text{C}$ and $V_{DD} = 5\text{ V}$, unless otherwise noted.

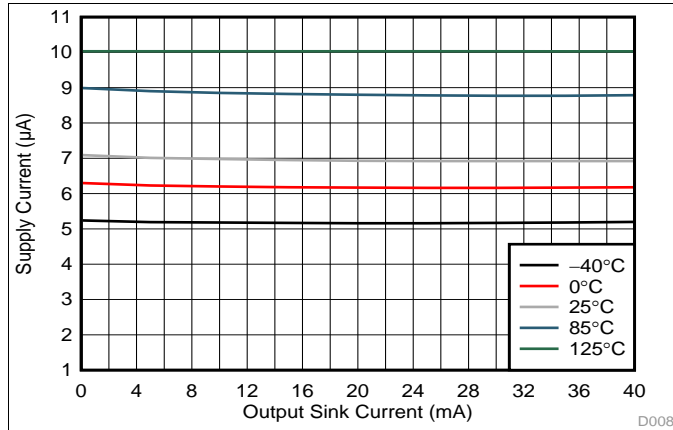

Figure 8. Supply Current (I_{DD}) vs Output Sink Current

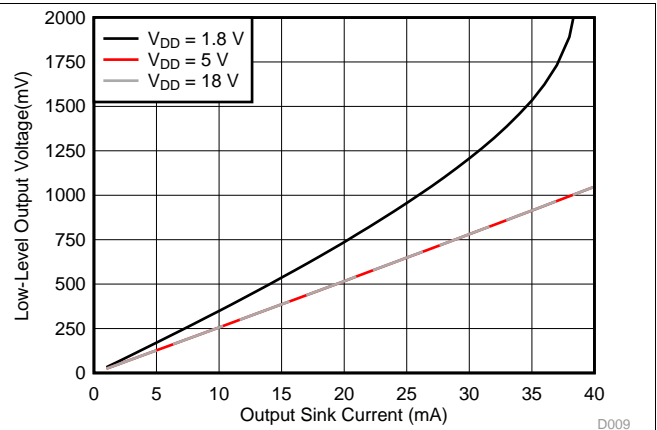

Figure 9. Output Voltage Low (V_{OL}) vs Output Sink Current (-40°C)

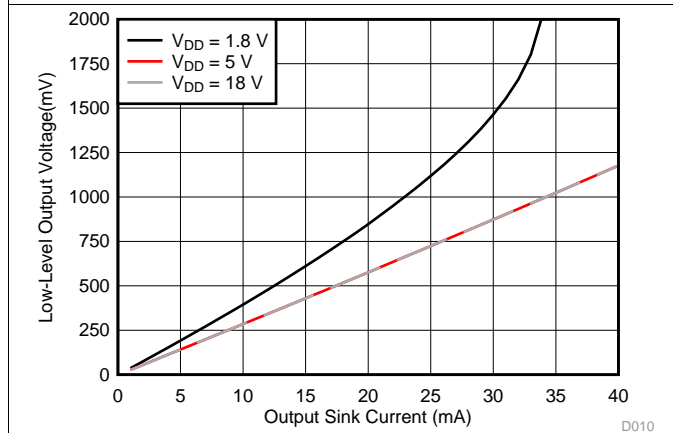

Figure 10. Output Voltage Low (V_{OL}) vs Output Sink Current (0°C)

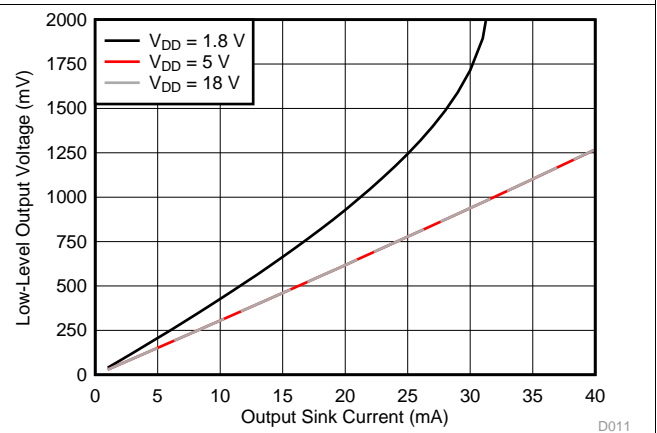

Figure 11. Output Voltage Low (V_{OL}) vs Output Sink Current (25°C)

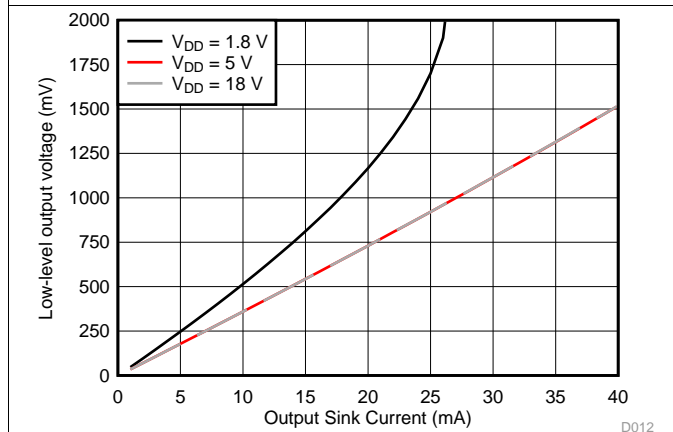

Figure 12. Output Voltage Low (V_{OL}) vs Output Sink Current (85°C)

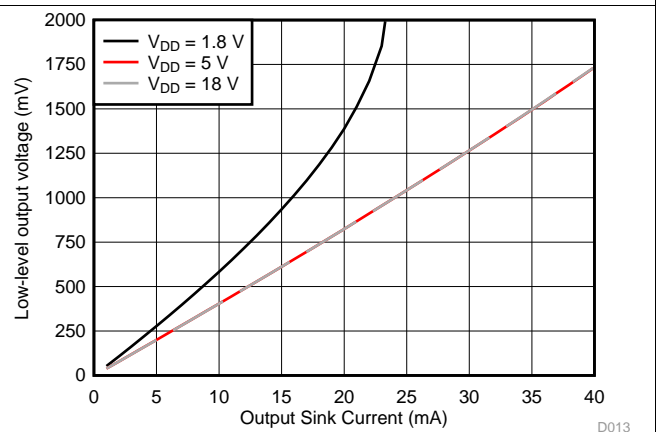

Figure 13. Output Voltage Low (V_{OL}) vs Output Sink Current (125°C)

8 Detailed Description

8.1 Overview

The TPS3700-Q1 device combines two comparators for overvoltage and undervoltage detection. The TPS3700-Q1 device is a wide-supply voltage range (1.8 to 18 V) device with a high-accuracy rising input threshold of 400 mV (1% over temperature) and built-in hysteresis. The outputs are also rated to 18 V and can sink up to 40 mA.

The TPS3700-Q1 device is designed to assert the output signals, as shown in [Table 1](#). Each input terminal can be set to monitor any voltage above 0.4 V using an external resistor divider network. With the use of two input terminals of different polarities, the TPS3700-Q1 device forms a window comparator. Broad voltage thresholds can be supported that allow the device to be used in a wide array of applications.

Table 1. TPS3700-Q1 Truth Table

CONDITION	OUTPUT	STATUS
$INA+ > V_{IT+}$	OUTA high	Output A not asserted
$INA+ < V_{IT-}$	OUTA low	Output A asserted
$INB- > V_{IT+}$	OUTB low	Output B asserted
$INB- < V_{IT-}$	OUTB high	Output B not asserted

8.2 Functional Block Diagram

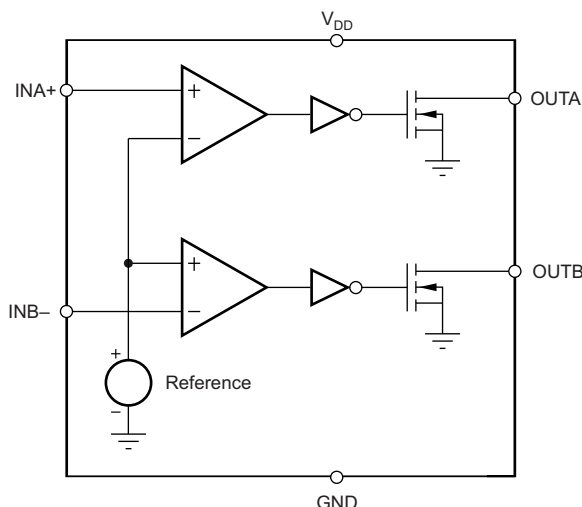

8.3 Feature Description

8.3.1 Inputs (INA+, INB-)

The TPS3700-Q1 device combines two comparators. Each comparator has one external input (inverting and noninverting); the other input is connected to the internal reference. The comparator rising threshold is designed and trimmed to be equal to the reference voltage (400 mV). Both comparators also have a built-in falling hysteresis that makes the device less sensitive to supply rail noise and ensures stable operation.

The comparator inputs can swing from ground to 6.5 V, regardless of the device supply voltage used. Although not required in most cases, it is good analog design practice to place a 1-nF to 10-nF bypass capacitor at the comparator input for extremely noisy applications in order to reduce sensitivity to transients and layout parasitics.

For comparator A, the corresponding output (OUTA) is driven to logic low when the input INA+ voltage drops below $(V_{IT+} - V_{hys})$. When the voltage exceeds V_{IT+} , the output (OUTA) goes to a high-impedance state; see [Figure 1](#).

Feature Description (continued)

For comparator B, the corresponding output (OUTB) is driven to logic low when the voltage at input INB– exceeds V_{IT+} . When the voltage drops below $V_{IT+} - V_{hys}$ the output (OUTB) goes to a high-impedance state; see [Figure 1](#). Together, these comparators form a window-detection function as discussed in the [Window Comparator](#) section.

8.3.2 Outputs (OUTA, OUTB)

In a typical TPS3700-Q1 application, the outputs are connected to a reset or enable input of the processor (such as a digital signal processor [DSP], central processing unit [CPU], field-programmable gate array [FPGA], or application-specific integrated circuit [ASIC]) or the outputs are connected to the enable input of a voltage regulator (such as a DC-DC or low-dropout regulator [LDO]).

The TPS3700-Q1 device provides two open-drain outputs (OUTA and OUTB). Pullup resistors must be used to hold these lines high when the output goes to high impedance (not asserted). By connecting pullup resistors to the proper voltage rails, the outputs can be connected to other devices at the correct interface-voltage levels. The TPS3700-Q1 outputs can be pulled up to 18 V, independent of the device supply voltage. To ensure proper voltage levels, some thought should be given while choosing the pullup resistor values. The pullup resistor value is determined by V_{OL} , sink-current capability, and output-leakage current ($I_{lkg(OD)}$). These values are specified in the [Electrical Characteristics](#) table. By using wired-AND logic, OUTA and OUTB can merge into one logic signal.

[Table 1](#) and the [Inputs \(INA+, INB–\)](#) section describe how the outputs are asserted or de-asserted. See [Figure 1](#) for a timing diagram that describes the relationship between threshold voltages and the respective output.

8.3.3 Window Comparator

The inverting and noninverting configuration of the comparators forms a window-comparator detection circuit using a resistor divider network, as shown in [Figure 14](#) and [Figure 15](#). The input terminals can monitor any system voltage above 400 mV with the use of a resistor divider network. The INA+ and INB– terminals monitor for undervoltage and overvoltage conditions, respectively.

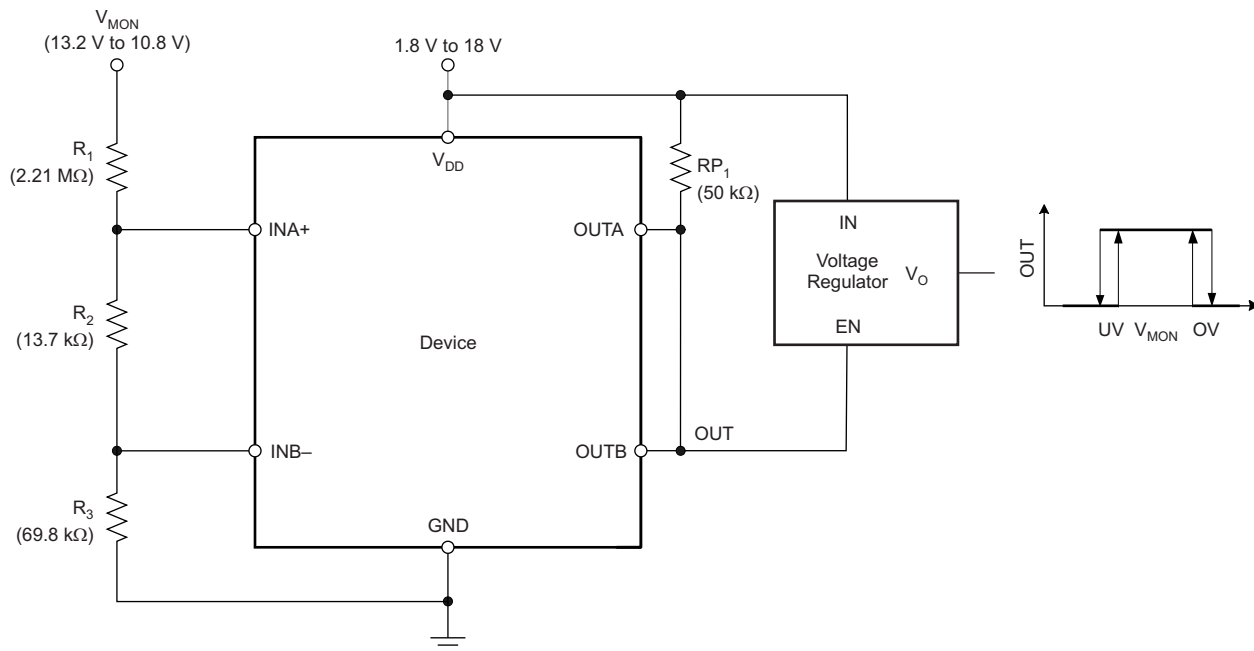

Figure 14. Window Comparator Block Diagram

Feature Description (continued)

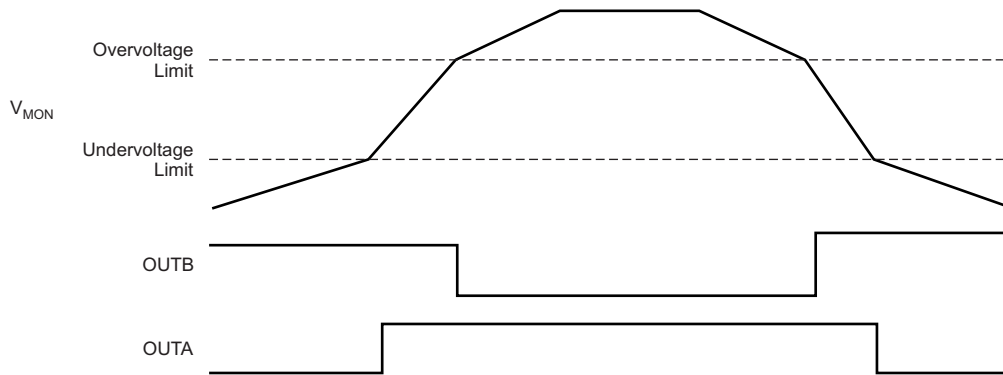

Figure 15. Window Comparator Timing Diagram

8.3.4 Immunity to Input Terminal Voltage Transients

The TPS3700-Q1 device is relatively immune to short voltage transient spikes on the input terminals. Sensitivity to transients is dependent on both transient duration and amplitude; see the *Minimum Pulse Width vs Threshold Overdrive Voltage* curve (Figure 7) in the [Typical Characteristics](#) section.

8.4 Device Functional Modes

The TPS3700-Q1 has a single functional mode, which is on when V_{DD} is greater than 1.8 V.

9 Application and Implementation

9.1 Application Information

The TPS3700-Q1 device is a wide-supply voltage window comparator that operates over a V_{DD} range of 1.8-V to 18-V. The device has two high-accuracy comparators with an internal 400-mV reference and two open-drain outputs rated to 18 V for overvoltage and undervoltage detection. The device can be used either as a window comparator or as two independent voltage monitors. The monitored voltages are set with the use of external resistors.

9.1.1 V_{PULLUP} to a Voltage Other Than V_{DD}

The outputs are often tied to V_{DD} through a resistor. However some applications may require the outputs to be pulled up to a higher or lower voltage than V_{DD} in order to correctly interface with the reset and enable the terminal of other devices.

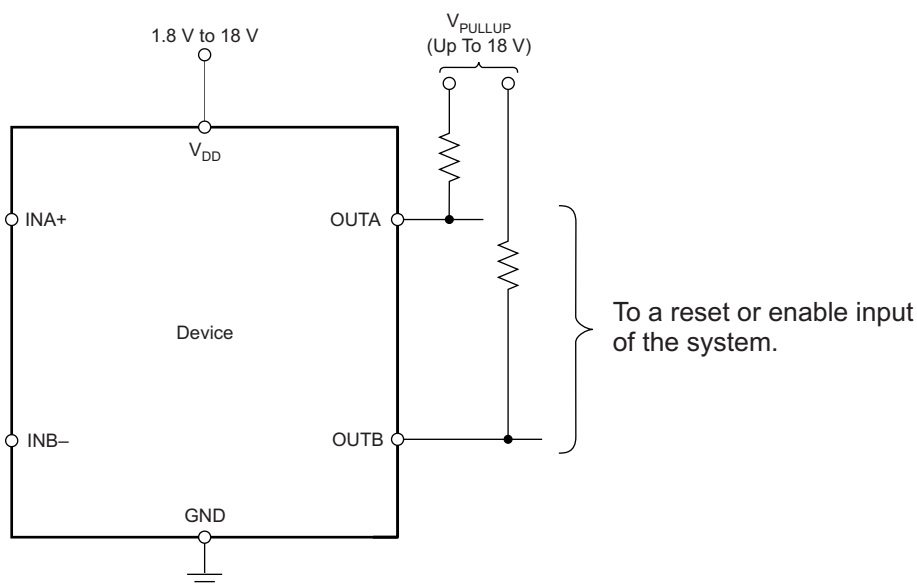

Figure 16. Interfacing to Voltages Other Than V_{DD}

Application Information (continued)

9.1.2 Monitoring V_{DD}

Many applications monitor the same rail that is powering V_{DD} . In these applications the resistor divider is simply connected to the V_{DD} rail.

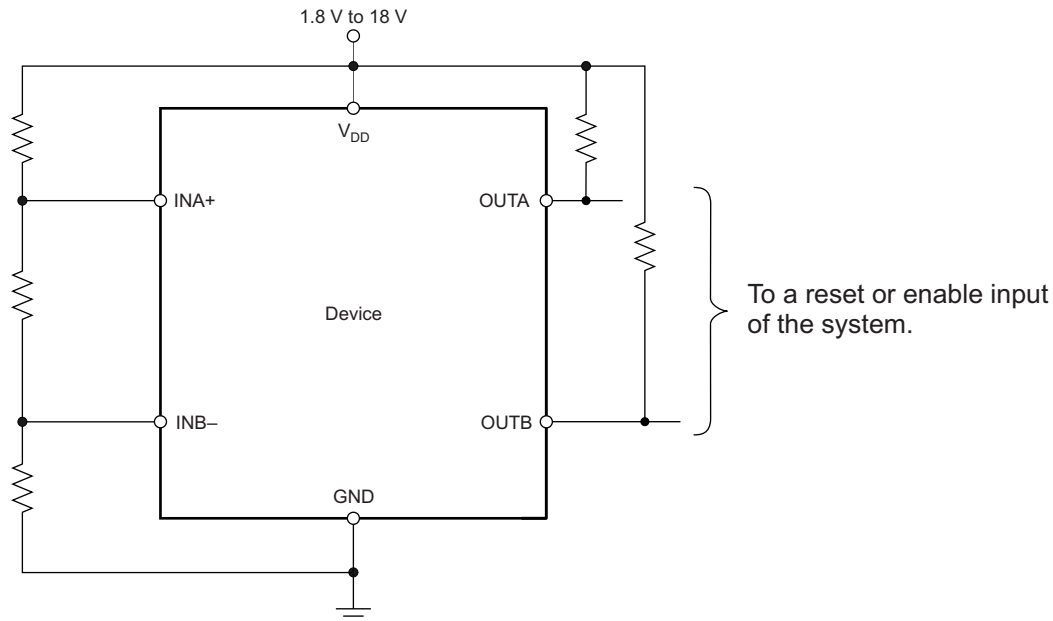
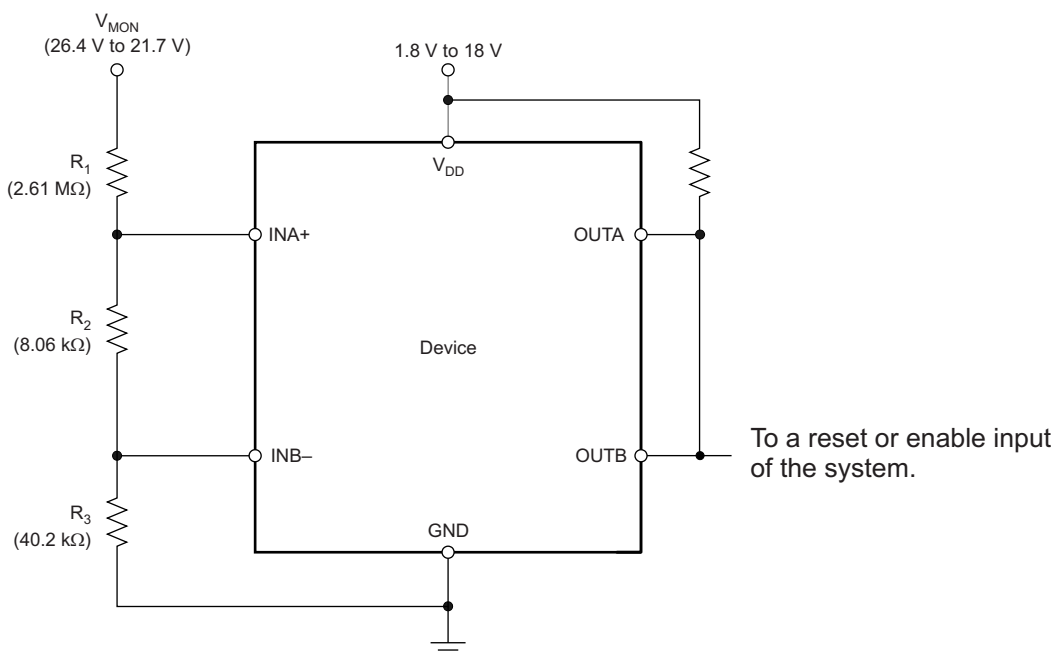

Figure 17. Monitoring the Same Voltage as V_{DD}

9.1.3 Monitoring a Voltage Other Than V_{DD}

Some applications monitor rails other than the one that is powering V_{DD} . In these types of applications the resistor divider used to set the desired thresholds is connected to the rail that is being monitored.



NOTE: The inputs can monitor a voltage higher than V_{DDmax} with the use of an external resistor divider network.

Figure 18. Monitoring a Voltage Other Than V_{DD}

Application Information (continued)

9.1.4 Monitoring Overvoltage and Undervoltage for Separate Rails

Some applications may want to monitor for overvoltage conditions on one rail while also monitoring for undervoltage conditions on a different rail. In those applications two independent resistor dividers will need to be used.

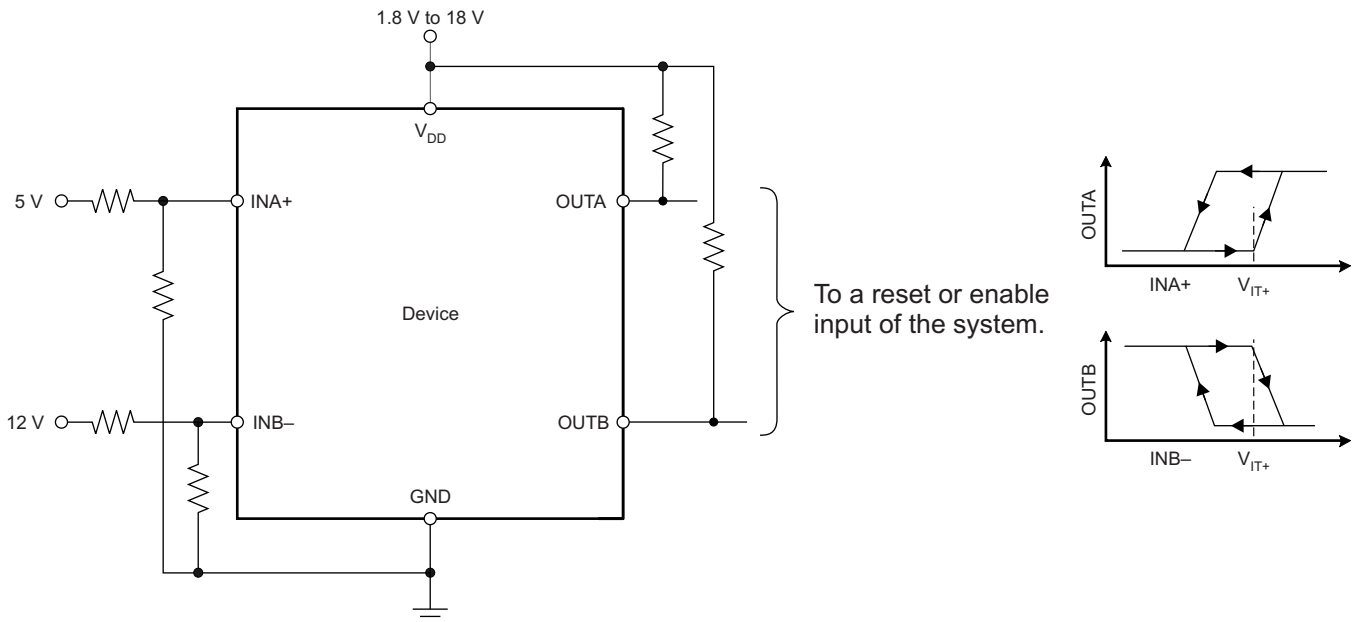

NOTE: In this case, OUTA is driven low when an undervoltage condition is detected at the 5-V rail and OUTB is driven low when an overvoltage condition is detected at the 12-V rail.

Figure 19. Monitoring Overvoltage for One Rail and Undervoltage for a Different Rail

9.2 Typical Application

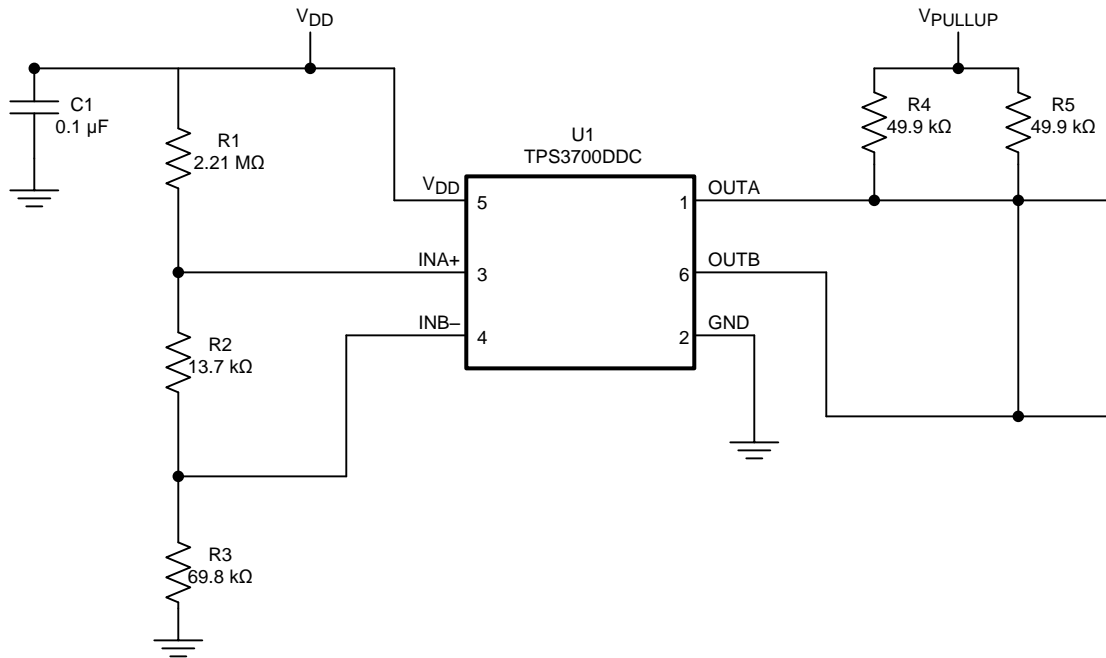

Figure 20. Typical Application Schematic

9.2.1 Design Requirements

9.2.1.1 Input Supply Capacitor

Although an input capacitor is not required for stability, connecting a 0.1-μF low equivalent series resistance (ESR) capacitor across the V_{DD} terminal and GND terminal is good analog design practice. A higher-value capacitor may be necessary if large, fast rise-time load transients are anticipated, or if the device is not located close to the power source.

9.2.1.2 Input Capacitors

Although not required in most cases, for extremely noisy applications, placing a 1-nF to 10-nF bypass capacitor from the comparator inputs (INA+, INB-) to the GND terminal is good analog design practice. This capacitor placement reduces device sensitivity to transients.

9.2.2 Detailed Design Procedure

Use Equation 1 through Equation 4 to calculate the resistor divider values and target threshold voltage.

$$R_T = R_1 + R_2 + R_3 \quad (1)$$

Select a value for R_T such that the current through the divider is approximately 100-times higher than the input current at the INA+ and INB- terminals. The resistors can have high values to minimize current consumption as a result of low-input bias current without adding significant error to the resistive divider. See the application note *Optimizing Resistor Dividers at a Comparator Input* (SLVA450) for details on sizing input resistors.

Use Equation 2 to calculate the value of R₃.

$$R_3 = \frac{R_T}{V_{\text{MON(OV)}}} \times V_{\text{IT+}}$$

where

- V_{MON(OV)} is the target voltage at which an overvoltage condition is detected (2)

Typical Application (continued)

Use [Equation 3](#) or [Equation 4](#) to calculate the value of R_2 .

$$R_2 = \left[\frac{R_T}{V_{\text{MON (no UV)}}} \times V_{\text{IT+}} \right] - R_3$$

where

- $V_{\text{MON(no UV)}}$ is the target voltage at which an undervoltage condition is removed as V_{MON} rises (3)

$$R_2 = \left[\frac{R_T}{V_{\text{MON(UV)}}} \times (V_{\text{IT+}} - V_{\text{hys}}) \right] - R_3$$

where:

- $V_{\text{MON(UV)}}$ is the target voltage at which an undervoltage condition is detected (4)

9.2.3 Application Curves

$T_J = 25^\circ\text{C}$

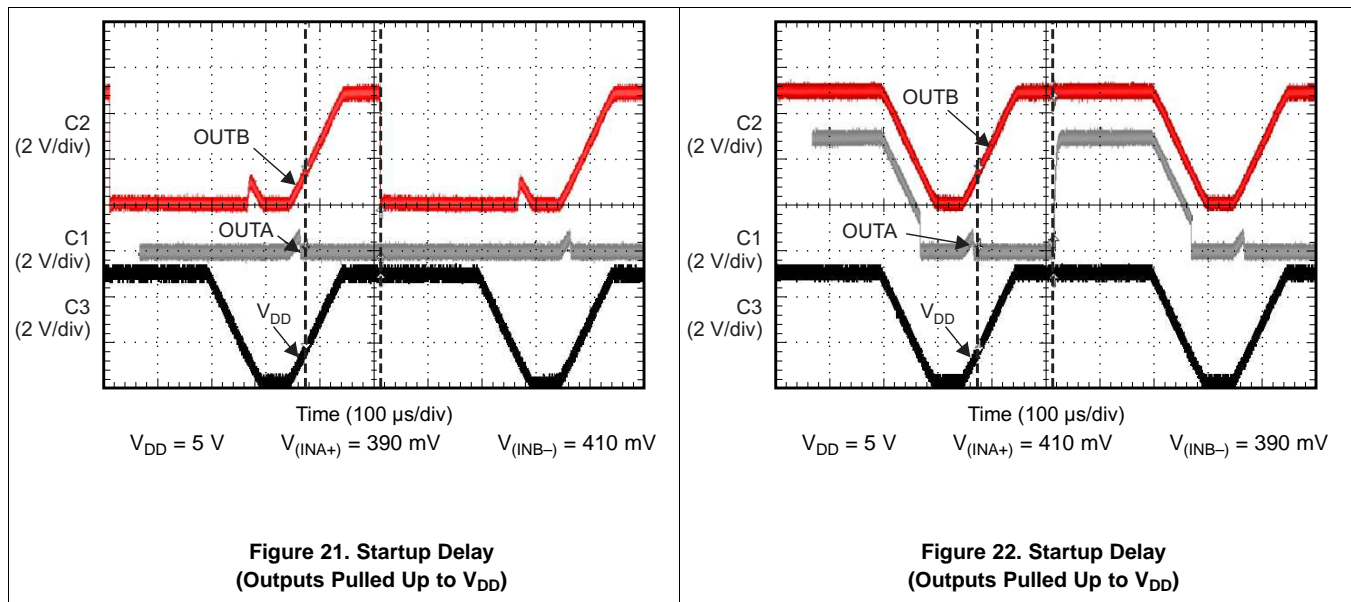

10 Power Supply Recommendations

These devices are designed to operate from an input voltage supply range between 1.8 V and 18 V.

11 Layout

11.1 Layout Guidelines

Placing a 0.1- μ F capacitor close to the V_{DD} terminal to reduce the input impedance to the device is good analog design practice. The pullup resistors can be separated if separate logic functions are needed (see Figure 23) or both resistors can be tied to a single pullup resistor if a logical AND function is desired.

11.2 Layout Example

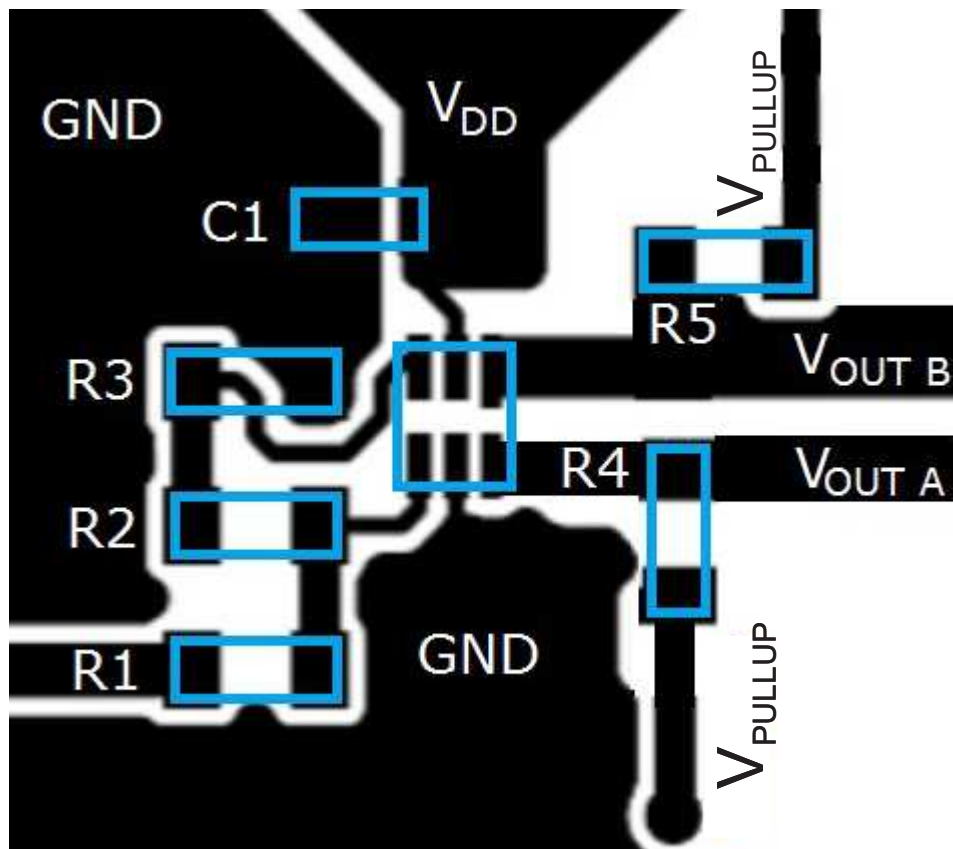

Figure 23. TPS3700-Q1 Layout Example

12 Device and Documentation Support

12.1 Documentation Support

12.1.1 Related Documentation

For related documentation see the following:

- *Using the TPS3700 as a Negative Rail Over- and Undervoltage Detector*, [SLVA600](#)
- *Optimizing Resistor Dividers at a Comparator Input*, [SLVA450](#)
- *TPS3700EVM-114 Evaluation Module*, [SLVU683](#)

12.2 Trademarks

All trademarks are the property of their respective owners.

12.3 Electrostatic Discharge Caution



These devices have limited built-in ESD protection. The leads should be shorted together or the device placed in conductive foam during storage or handling to prevent electrostatic damage to the MOS gates.

12.4 Glossary

[SLYZ022](#) — *TI Glossary*.

This glossary lists and explains terms, acronyms, and definitions.

13 Mechanical, Packaging, and Orderable Information

The following pages include mechanical packaging and orderable information. This information is the most current data available for the designated devices. This data is subject to change without notice and revision of this document. For browser-based versions of this data sheet, refer to the left-hand navigation.

PACKAGING INFORMATION

Orderable Device	Status (1)	Package Type	Package Drawing	Pins	Package Qty	Eco Plan (2)	Lead/Ball Finish (6)	MSL Peak Temp (3)	Op Temp (°C)	Device Marking (4/5)	Samples
TPS3700QDDCRQ1	ACTIVE	SOT-23-THIN	DDC	6	3000	Green (RoHS & no Sb/Br)	CU NIPDAU	Level-2-260C-1 YEAR	-40 to 125	PD7Q	Samples
TPS3700QDSEQRQ1	ACTIVE	WSON	DSE	6	3000	Green (RoHS & no Sb/Br)	CU NIPDAUAG	Level-2-260C-1 YEAR	-40 to 125	5O	Samples

(1) The marketing status values are defined as follows:

ACTIVE: Product device recommended for new designs.

LIFEBUY: TI has announced that the device will be discontinued, and a lifetime-buy period is in effect.

NRND: Not recommended for new designs. Device is in production to support existing customers, but TI does not recommend using this part in a new design.

PREVIEW: Device has been announced but is not in production. Samples may or may not be available.

OBSOLETE: TI has discontinued the production of the device.

(2) **RoHS:** TI defines "RoHS" to mean semiconductor products that are compliant with the current EU RoHS requirements for all 10 RoHS substances, including the requirement that RoHS substance do not exceed 0.1% by weight in homogeneous materials. Where designed to be soldered at high temperatures, "RoHS" products are suitable for use in specified lead-free processes. TI may reference these types of products as "Pb-Free".

RoHS Exempt: TI defines "RoHS Exempt" to mean products that contain lead but are compliant with EU RoHS pursuant to a specific EU RoHS exemption.

Green: TI defines "Green" to mean the content of Chlorine (Cl) and Bromine (Br) based flame retardants meet JS709B low halogen requirements of <=1000ppm threshold. Antimony trioxide based flame retardants must also meet the <=1000ppm threshold requirement.

(3) MSL, Peak Temp. - The Moisture Sensitivity Level rating according to the JEDEC industry standard classifications, and peak solder temperature.

(4) There may be additional marking, which relates to the logo, the lot trace code information, or the environmental category on the device.

(5) Multiple Device Markings will be inside parentheses. Only one Device Marking contained in parentheses and separated by a "-" will appear on a device. If a line is indented then it is a continuation of the previous line and the two combined represent the entire Device Marking for that device.

(6) Lead/Ball Finish - Orderable Devices may have multiple material finish options. Finish options are separated by a vertical ruled line. Lead/Ball Finish values may wrap to two lines if the finish value exceeds the maximum column width.

Important Information and Disclaimer:The information provided on this page represents TI's knowledge and belief as of the date that it is provided. TI bases its knowledge and belief on information provided by third parties, and makes no representation or warranty as to the accuracy of such information. Efforts are underway to better integrate information from third parties. TI has taken and continues to take reasonable steps to provide representative and accurate information but may not have conducted destructive testing or chemical analysis on incoming materials and chemicals. TI and TI suppliers consider certain information to be proprietary, and thus CAS numbers and other limited information may not be available for release.

In no event shall TI's liability arising out of such information exceed the total purchase price of the TI part(s) at issue in this document sold by TI to Customer on an annual basis.

OTHER QUALIFIED VERSIONS OF TPS3700-Q1 :

- Catalog: [TPS3700](#)

NOTE: Qualified Version Definitions:

- Catalog - TI's standard catalog product

TAPE AND REEL INFORMATION



QUADRANT ASSIGNMENTS FOR PIN 1 ORIENTATION IN TAPE



*All dimensions are nominal

Device	Package Type	Package Drawing	Pins	SPQ	Reel Diameter (mm)	Reel Width W1 (mm)	A0 (mm)	B0 (mm)	K0 (mm)	P1 (mm)	W (mm)	Pin1 Quadrant
TPS3700QDDCRQ1	SOT-23-THIN	DDC	6	3000	179.0	8.4	3.2	3.2	1.4	4.0	8.0	Q3
TPS3700QDSERQ1	WSON	DSE	6	3000	179.0	8.4	1.8	1.8	1.0	4.0	8.0	Q2

TAPE AND REEL BOX DIMENSIONS

*All dimensions are nominal

Device	Package Type	Package Drawing	Pins	SPQ	Length (mm)	Width (mm)	Height (mm)
TPS3700QDDCRQ1	SOT-23-THIN	DDC	6	3000	195.0	200.0	45.0
TPS3700QDSERQ1	WSON	DSE	6	3000	195.0	200.0	45.0

DSE (S-PDSO-N6)

PLASTIC SMALL OUTLINE



4207810/A 03/06

- NOTES:
- A. All linear dimensions are in millimeters.
 - B. This drawing is subject to change without notice.
 - C. Small Outline No-Lead (SON) package configuration.
 - D. This package is lead-free.

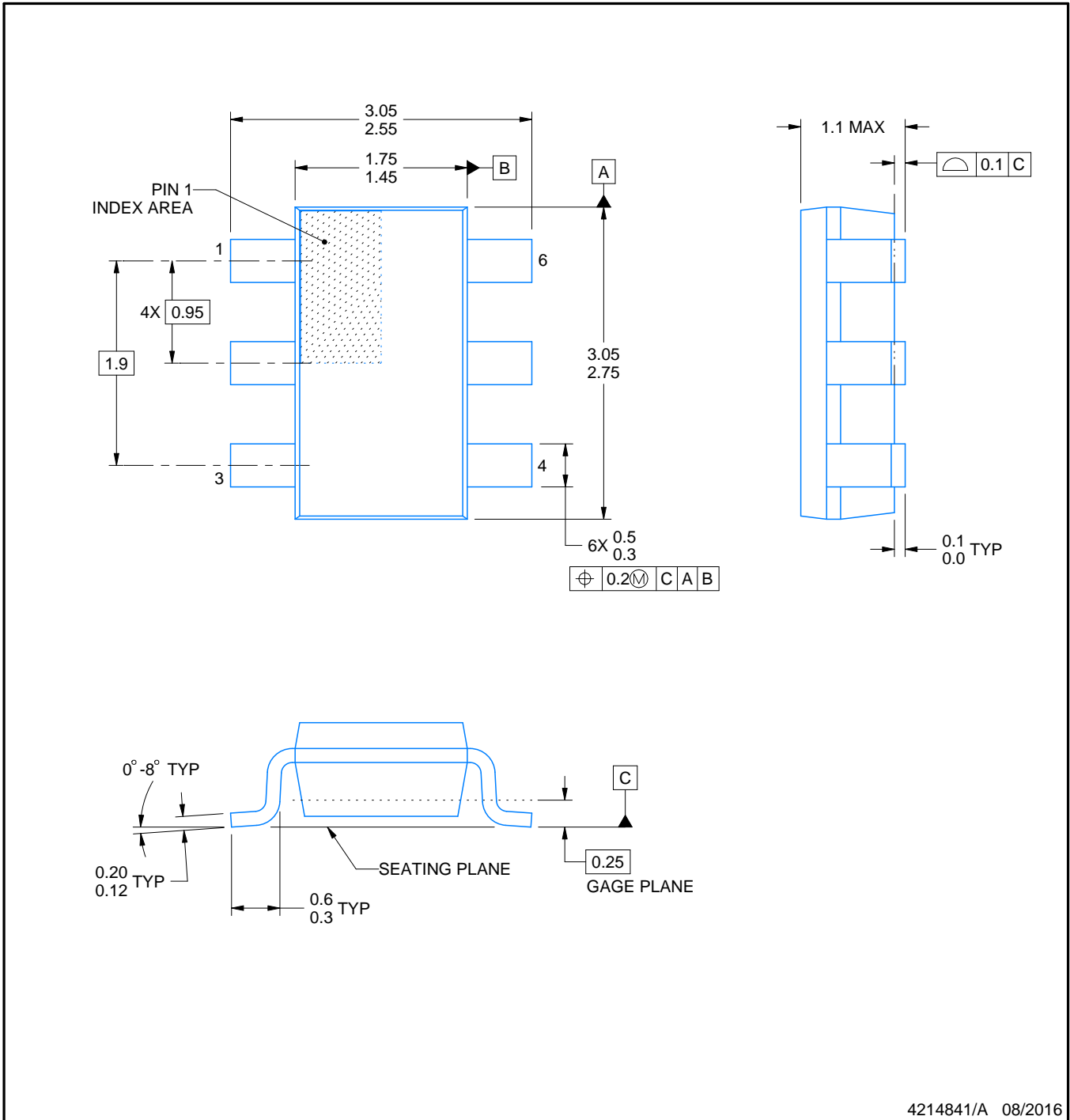

NOTES:

1. All linear dimensions are in millimeters. Any dimensions in parenthesis are for reference only. Dimensioning and tolerancing per ASME Y14.5M.
2. This drawing is subject to change without notice.
3. Reference JEDEC MO-193.

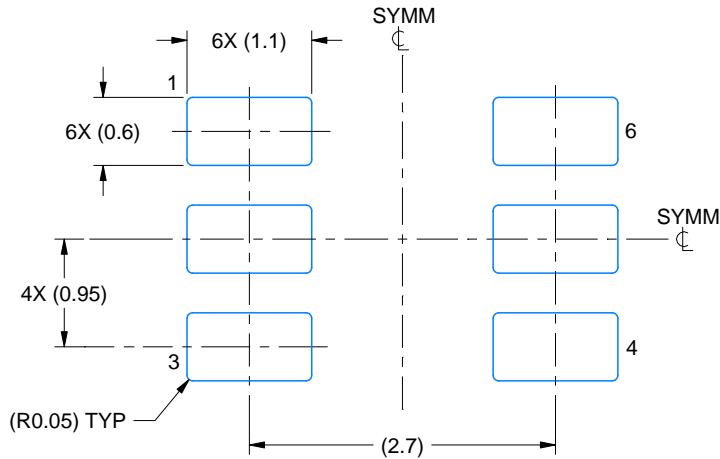

LAND PATTERN EXAMPLE
EXPLODED METAL SHOWN
SCALE:15X

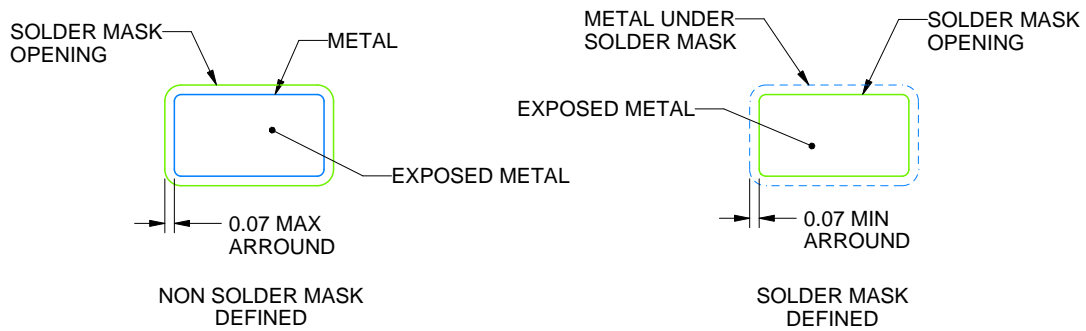

SOLDEMASK DETAILS

4214841/A 08/2016

NOTES: (continued)

- 4. Publication IPC-7351 may have alternate designs.
- 5. Solder mask tolerances between and around signal pads can vary based on board fabrication site.

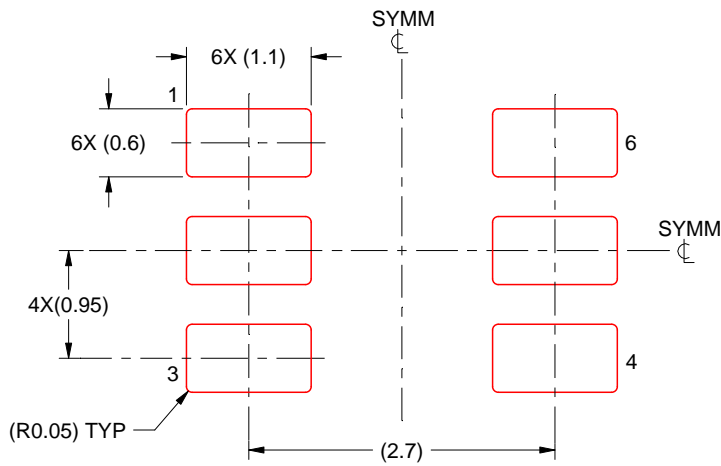

SOLDER PASTE EXAMPLE
BASED ON 0.125 THICK STENCIL
SCALE:15X

4214841/A 08/2016

NOTES: (continued)

6. Laser cutting apertures with trapezoidal walls and rounded corners may offer better paste release. IPC-7525 may have alternate design recommendations.
7. Board assembly site may have different recommendations for stencil design.

IMPORTANT NOTICE AND DISCLAIMER

TI PROVIDES TECHNICAL AND RELIABILITY DATA (INCLUDING DATASHEETS), DESIGN RESOURCES (INCLUDING REFERENCE DESIGNS), APPLICATION OR OTHER DESIGN ADVICE, WEB TOOLS, SAFETY INFORMATION, AND OTHER RESOURCES "AS IS" AND WITH ALL FAULTS, AND DISCLAIMS ALL WARRANTIES, EXPRESS AND IMPLIED, INCLUDING WITHOUT LIMITATION ANY IMPLIED WARRANTIES OF MERCHANTABILITY, FITNESS FOR A PARTICULAR PURPOSE OR NON-INFRINGEMENT OF THIRD PARTY INTELLECTUAL PROPERTY RIGHTS.

These resources are intended for skilled developers designing with TI products. You are solely responsible for (1) selecting the appropriate TI products for your application, (2) designing, validating and testing your application, and (3) ensuring your application meets applicable standards, and any other safety, security, or other requirements. These resources are subject to change without notice. TI grants you permission to use these resources only for development of an application that uses the TI products described in the resource. Other reproduction and display of these resources is prohibited. No license is granted to any other TI intellectual property right or to any third party intellectual property right. TI disclaims responsibility for, and you will fully indemnify TI and its representatives against, any claims, damages, costs, losses, and liabilities arising out of your use of these resources.

TI's products are provided subject to TI's Terms of Sale (www.ti.com/legal/termsofsale.html) or other applicable terms available either on ti.com or provided in conjunction with such TI products. TI's provision of these resources does not expand or otherwise alter TI's applicable warranties or warranty disclaimers for TI products.

Mailing Address: Texas Instruments, Post Office Box 655303, Dallas, Texas 75265
Copyright © 2019, Texas Instruments Incorporated