

## Non-Synchronous PWM Boost Controller for LED Driver



### General Description

The FP7209 is boost topology switching regulator for LED driver. It provides built-in gate driver pin for driving external N-MOSFET. The non-inverting input of error amplifier connects to a 0.25V reference voltage. There are three functions to protect system circuit like UVP, OVP and OCP. The LED current can be adjusted by an external signal connecting to the DIM pin. DIM pin accepts either a DC voltage or a PWM signal. The PWM signal filter components are contained within the chip. Current mode control and external compensation network make is easy and flexible to stabilize the system.

The FP7209 is available in the small footprint SOP-8L(EP) package to fit in space-saving PCB layout for application fields.

### Features

- Start-up Voltage: 2.8V
- Wide Supply Voltage Operating Range: 5V to 24V
- Precision Feedback Reference Voltage: 0.25V (Max.)
- Analog and Digital Dimming Control
- Shutdown Current: 6 $\mu$ A (Max.)
- Fixed Switching Frequency: 150KHz
- Input Under Voltage Protection (UVP)
- Output Over Voltage Protection (OVP)
- Switching MOSFET Over Current Protection (OCP)
- Over Temperature Protection (OTP)
- Package: SOP-8L(EP)

### Applications

- LED Module
- Display Backlight
- Car Lighting
- Portable LED Lighting

### Typical Application Circuit

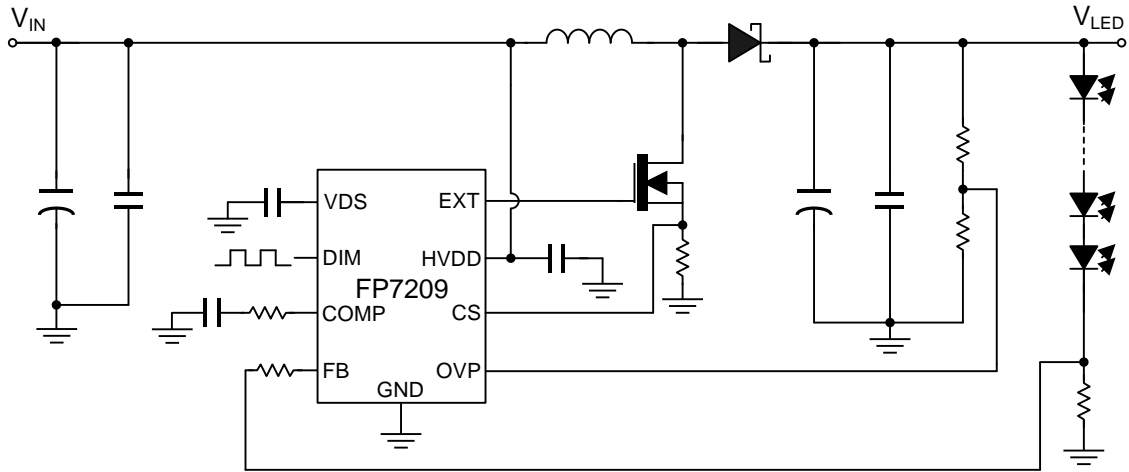

### Function Block Diagram

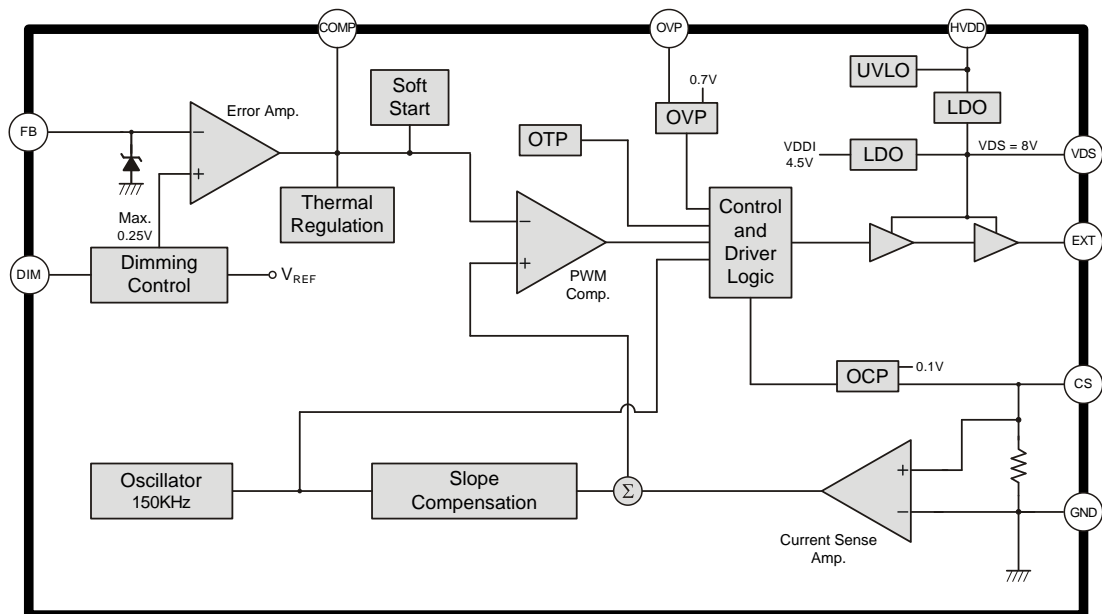

## Pin Descriptions

### SOP-8L(EP)

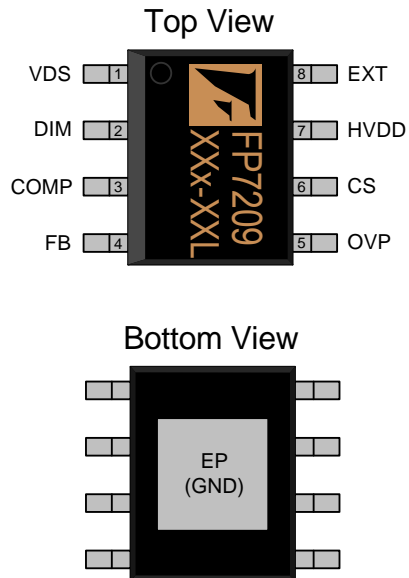

Name	No.	I / O	Description
VDS	1	P	Power Supply for Internal Control Circuits and Gate Drivers
DIM	2	I	Analog and Digital Dimming Control
COMP	3	O	Compensation
FB	4	I	Error Amplifier Inverting Input
OVP	5	I	Over Voltage Protection
CS	6	I	MOSFET Switch Current Sense
HVDD	7	P	IC Power Supply
EXT	8	O	Gate Driver Output
GND	9(EP)	P	IC Ground (Exposed PAD) – Must Connect to Ground

## Marking Information

### SOP-8L(EP)

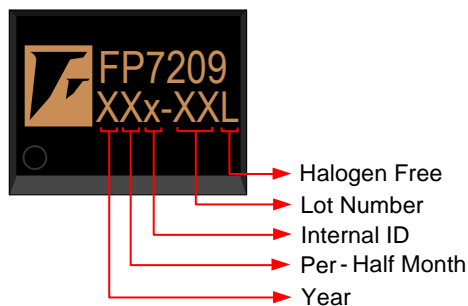

**Halogen Free:** Halogen free product indicator

**Lot Number:** Wafer lot number's code

**Internal ID:** Internal Identification Code

**Per-Half Month:** Production period indicator in half month time unit

For Example : A → First Half Month of January

B → Second Half Month of January

C → First Half Month of February

D → Second Half Month of February

**Year:** Production year's last digit

This datasheet contains new product information. Advanced Analog Technology reserves the rights to modify the product specification without notice. No liability is assumed as a result of the use of this product. No rights under any patent accompany the sales of the product.

## Ordering Information

Part Number	Operating Temperature	Package	MOQ	Description
FP7209XR-G11	-40°C ~ +85°C	SOP-8L(EP)	2500EA	Tape & Reel
FP7209XR-G12	-40°C ~ +85°C	SOP-8L(EP)	2500EA	Tape & Reel
FP7209XR-G13	-40°C ~ +85°C	SOP-8L(EP)	2500EA	Tape & Reel

## Absolute Maximum Ratings

Parameter	Symbol	Conditions	Min.	Typ.	Max.	Unit
Supply Voltage	HVDD	-	-0.3	-	26	V
VDS,EXT Voltage	-	-	-0.3	-	16	V
Others Pin Voltage	-	-	-0.3	-	6	V
Thermal Resistance (Junction to Ambient)	$\theta_{JA}$	SOP-8L(EP)	-	-	+60	°C / W
Thermal Resistance (Junction to Case)	$\theta_{JC}$	SOP-8L(EP)	-	-	+10	°C / W
Junction Temperature	$T_J$	-	-	-	+150	°C
Operating Temperature	$T_{OP}$	-	-40	-	+85	°C
Storage Temperature	$T_{ST}$	-	-65	-	+150	°C
Lead Temperature	-	(soldering, 10 sec)	-	-	+260	°C

## IR Re-flow Soldering Curve

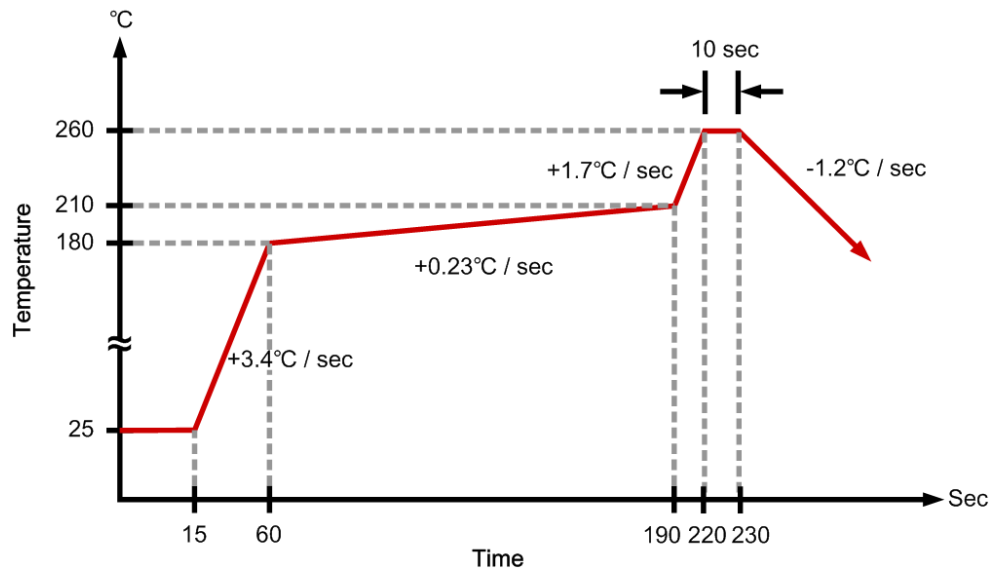

This datasheet contains new product information. Advanced Analog Technology reserves the rights to modify the product specification without notice. No liability is assumed as a result of the use of this product. No rights under any patent accompany the sales of the product.

## Recommended Operating Conditions

Parameter	Symbol	Conditions	Min.	Typ.	Max.	Unit
Supply Voltage	HVDD	-	5	-	24	V
Operating Temperature Range	T <sub>A</sub>	Ambient Temperature	-40	-	+85	°C

## DC Electrical Characteristics (HVDD=12V, T<sub>A</sub>=25°C, unless otherwise specified)

Parameter	Symbol	Conditions	Min.	Typ.	Max.	Unit
<b>System Supply Input</b>						
Start-up Voltage	HV <sub>DD</sub>		2.8			V
Input Supply Range	HV <sub>DD</sub>		5		24	V
Under Voltage Lockout	V <sub>UVLO</sub>			2.6		V
UVLO Hysteresis				0.2		V
Average Current	I <sub>CC</sub>	FB=0V, Switching		2		mA
Quiescent Current	I <sub>CC</sub>	FB=0.3V, No Switching		800		μA
Shutdown Current	I <sub>CC</sub>	V <sub>DIM</sub> =0V			6	μA
Input Supply Voltage	V <sub>DS</sub>	HV <sub>DD</sub> =12V, I <sub>DS</sub> =0A	7.5	8.0	8.5	V
<b>Oscillator</b>						
Operation Frequency	f <sub>OSC</sub>		120	150	180	KHz
Maximum Duty Ratio	%	FB=0V		90		%
<b>DIM Voltage</b>						
DIM Start-up Voltage	V <sub>st_up</sub>	EXT Switching		0.275		V
DIM Shutdown Voltage	V <sub>DIM</sub>	I <sub>CC</sub> <6μA	0.05			V
<b>Reference Voltage</b>						
Feedback Voltage	V <sub>FB</sub> *1	FP7209XR-G11	0.2525		0.2575	V
		FP7209XR-G12	0.2475		0.2525	V
		FP7209XR-G13	0.2425		0.2475	V
<b>External Transistor Connection current</b>						
EXT Pull-UP Resistance	R <sub>EXTH</sub>	V <sub>DS</sub> =8V	0.6	0.9	1.2	Ω
EXT Pull-Down Resistance	R <sub>EXTL</sub>	V <sub>DS</sub> =8V	0.6	0.9	1.2	Ω
<b>Over Voltage Protection</b>						
OVP Threshold	V <sub>OVP</sub>		0.65	0.70	0.75	V
<b>Current Sense Voltage</b>						
Sense Voltage	V <sub>CS</sub>		85	100	115	mV
<b>Thermal Shutdown</b>						
Thermal Shutdown Threshold	T <sub>TS</sub>			+150		°C
Thermal Shutdown Threshold Hysteresis	T <sub>TSH</sub>			30		°C

\*1 : Test error is not included, such as test machine, test board, contact resistance and so on. The total error results in drift of V<sub>FB</sub> about ±3mV.

## Typical Operating Characteristics

( $V_{IN}=12V$ ,  $T_A=25^{\circ}C$ , unless otherwise specified)

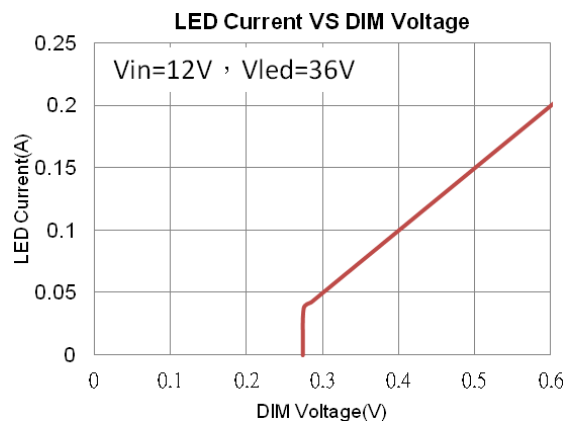
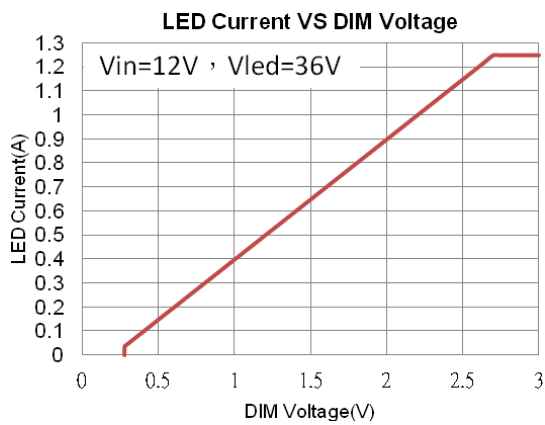
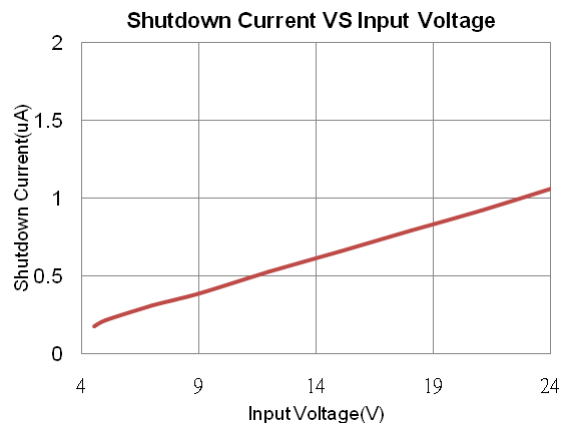
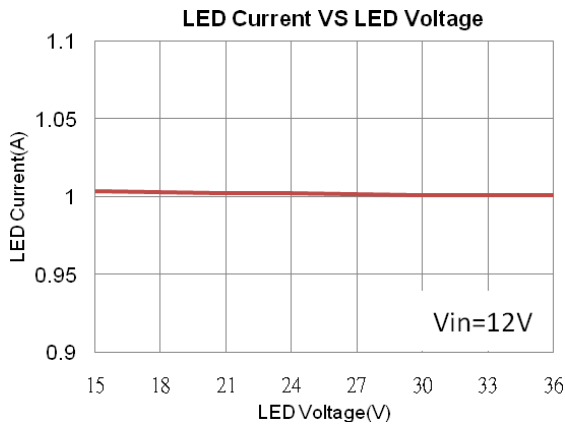
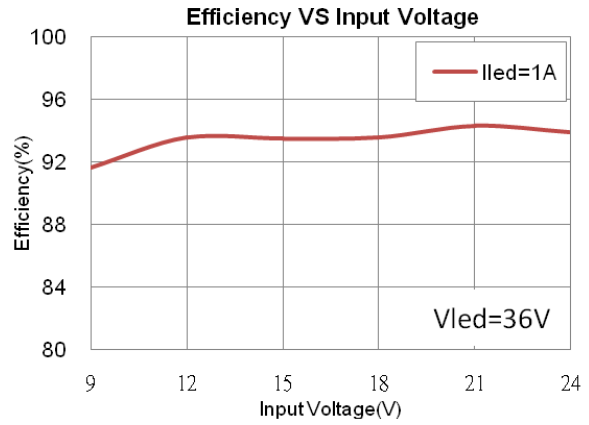
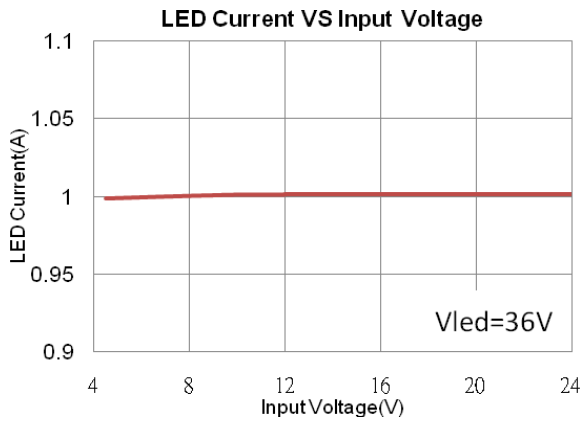

This datasheet contains new product information. Advanced Analog Technology reserves the rights to modify the product specification without notice. No liability is assumed as a result of the use of this product. No rights under any patent accompany the sales of the product.

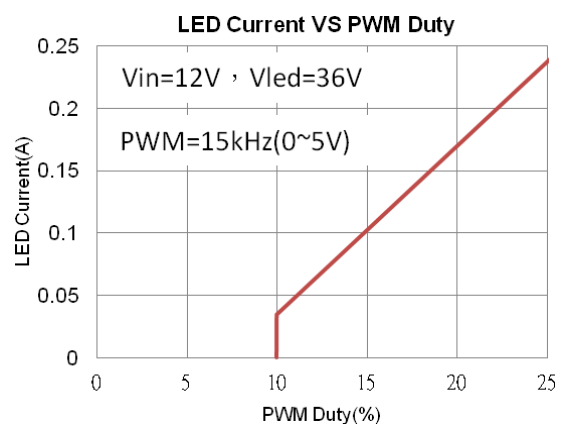
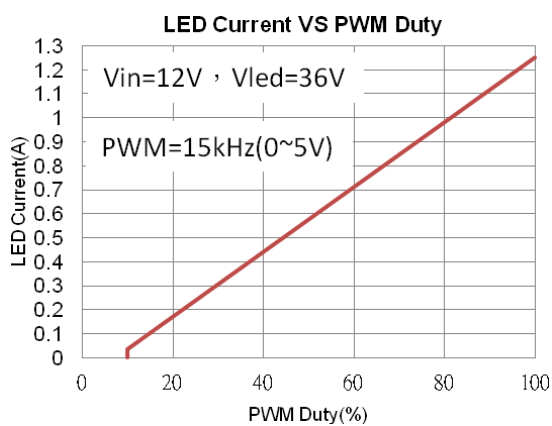
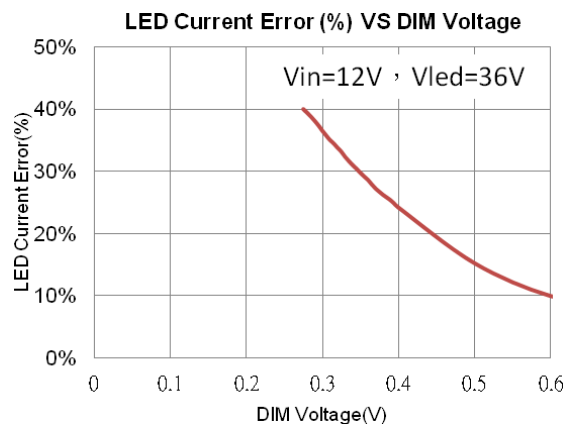
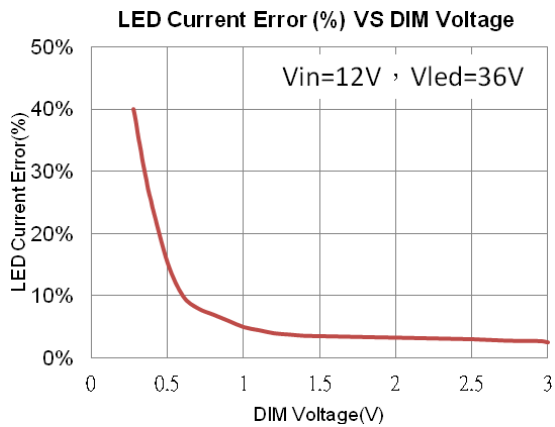
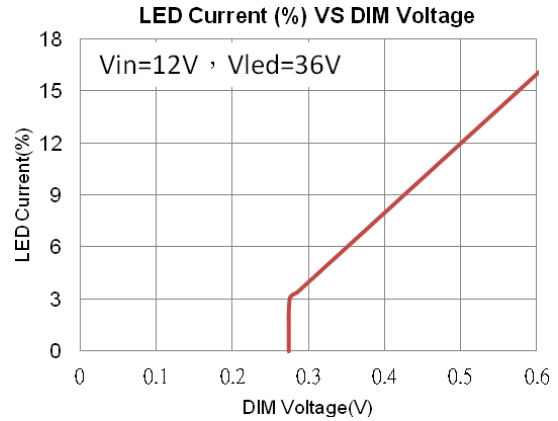
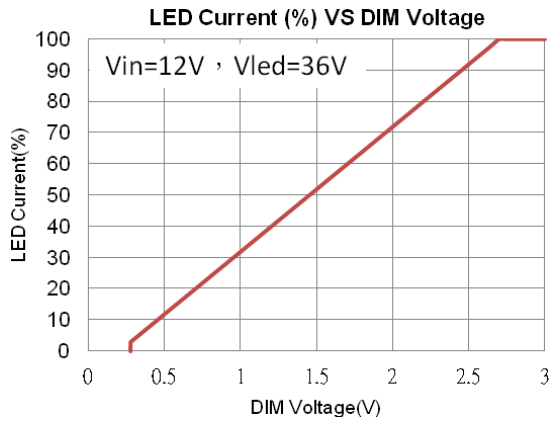

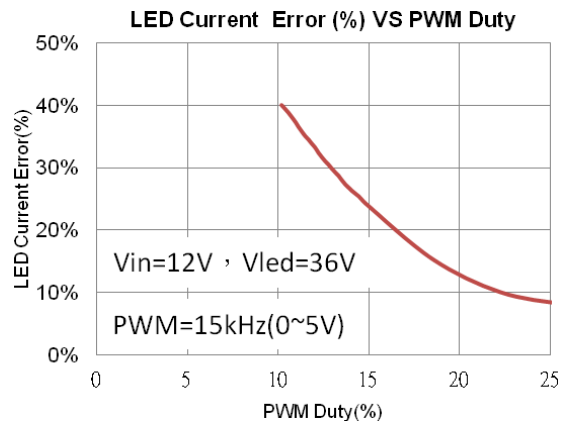
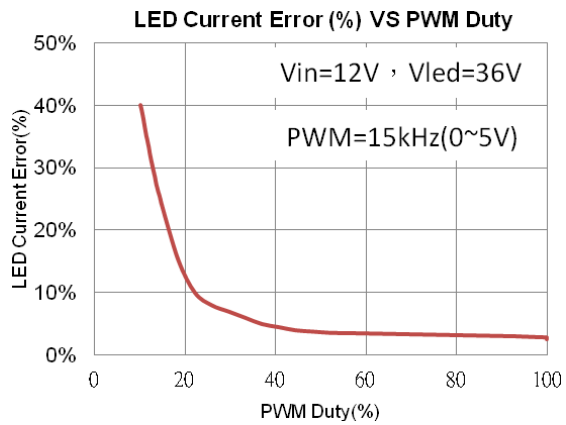
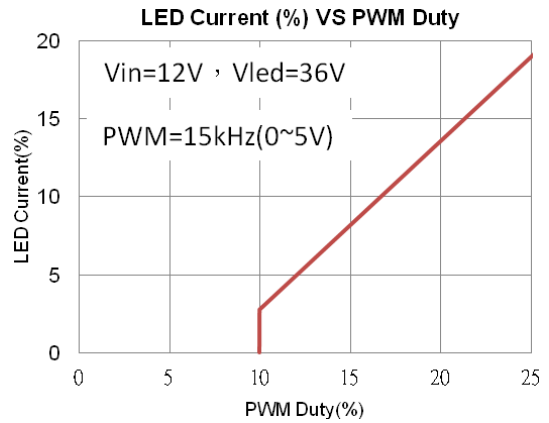
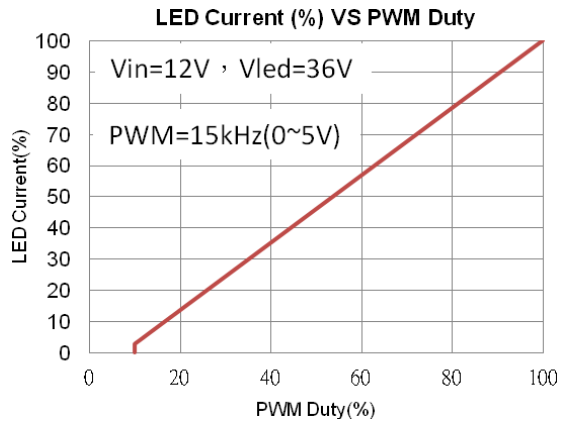



Power ON From DIM

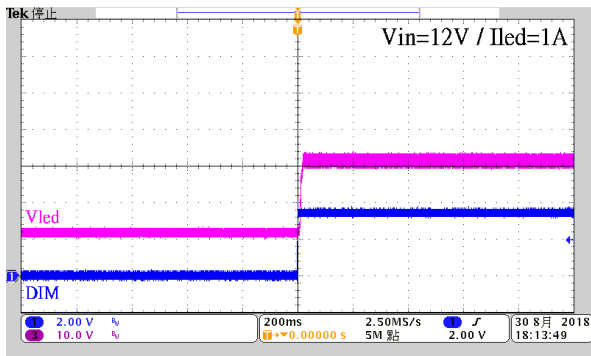

Power OFF From DIM

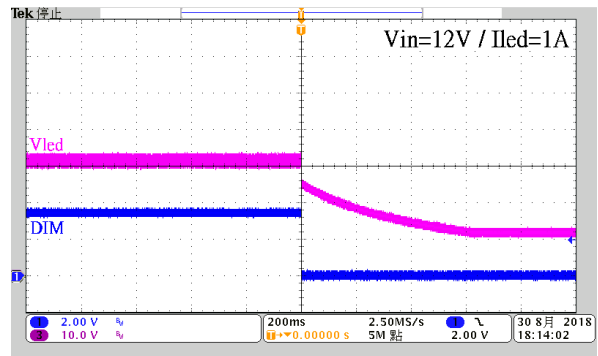

PWM Dimming From DIM

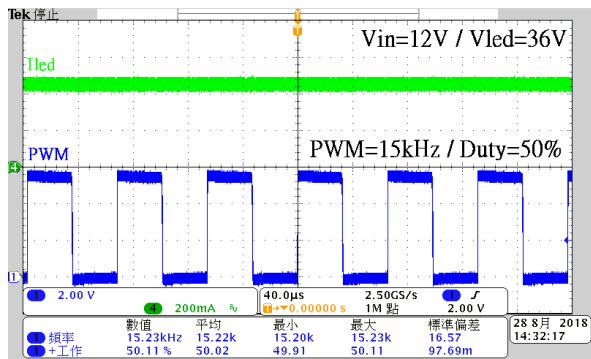

LED Open

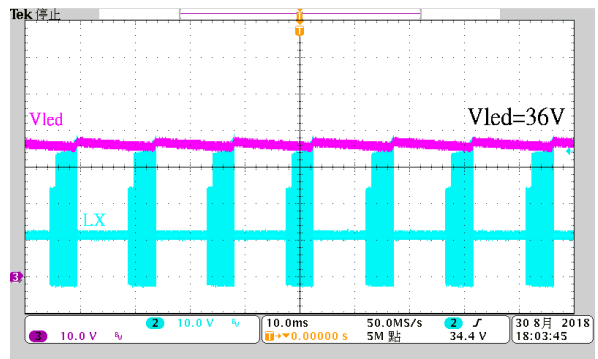

This datasheet contains new product information. Advanced Analog Technology reserves the rights to modify the product specification without notice. No liability is assumed as a result of the use of this product. No rights under any patent accompany the sales of the product.

## Function Description

### Operation

The FP7209 is current mode boost controller for LED driver, which provides fast transient response; external compensation network is easy and flexible to stabilize the system. FP7209 features a constant frequency, peak current mode control with slope compensation. The internal resistive divider provides 0.25V reference for the error amplifier, low reference voltage can reduce the power dissipation in the current sense resistor. To control DIM pin can achieve PWM and analog dimming of LED current.

### Current Sense Control

External switching MOSFET is turned on inductor current flows across the current sense resistor to generate  $V_{CS}$ .  $V_{CS}$  provides part of current mode control loop. Internal leading-edge blanking is provided to prevent premature turn off the switching MOSFET in each switching cycle.

### Current Limit Setting Resistor ( $R_{CS}$ )

$R_{CS}$  is connected between CS pin and ground, its calculation formula is as below. Where 0.085V is minimum threshold voltage of current sense,  $I_{Lp}$  is peak inductor current, and the factor 1.3 provides a 30% margin for tolerances.

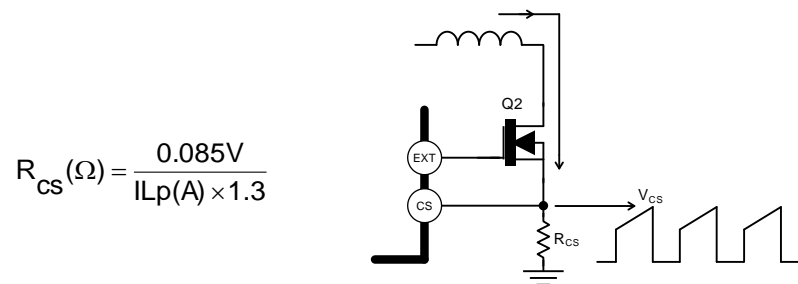

According to following equations calculate the peak inductor current  $I_{Lp}$ . Where  $I_{Lavg}$  is the average inductor current,  $I_{Lpp}$  is the peak-to-peak inductor current,  $V_{out}$  is the LED voltage,  $I_{out(max)}$  is the LED maximum current,  $Eff$  is the efficiency,  $F_s$  is the switching frequency, and the  $L$  is inductance.

$$I_{Lp} = I_{Lavg} + \frac{I_{Lpp}}{2}$$

$$I_{Lavg} = \frac{V_{out} \times I_{out(max)}}{V_{in} \times Eff}$$

$$I_{Lpp} = \left\langle \frac{V_{in}}{V_{out}} \right\rangle^2 \times \left\langle \frac{V_{out} - V_{in}}{F_s \times I_{out(max)}} \right\rangle \times \left\langle \frac{Eff}{L} \right\rangle \times I_{Lavg}$$

### Shutdown Mode

FP7209 goes into shutdown mode when DIM voltage is lower than 0.05V. In shutdown mode, to turn off circuitry includes EXT signal, VDS voltage, and supply current of HVDD reduces less than 6μA.

### DC Dimming Control

The DC voltage is connected to DIM pin change the voltage to adjust feedback voltage ( $V_{FB}$ ). The valid range of DIM voltage is from 0.275V to 2.7V then  $V_{FB}$  is adjusted from 7.5mV to 250mV (LED Current 3%~100%). The DIM has clamping circuit to limit internal maximum voltage in 2.7V.  $V_{FB}$  is still 0.25V even if DIM voltage exceeds 2.7V. The LED current ( $I_{LED}$ ) is calculated using formula as below.

$$V_{FB} = \frac{V_{DIM} - 0.2V}{10}, \quad I_{LED} = \frac{V_{FB}}{R_S}$$

### PWM Dimming Control

The PWM signal is connected to DIM pin changes PWM duty cycle to adjust feedback voltage ( $V_{FB}$ ). The valid range of PWM duty from 10.2% to 100% then  $V_{FB}$  is adjusted from 7.5mV to 250mV (LED Current 3%~100%). The DIM has clamping circuit to limit internal maximum voltage in 2.7V. If dimming PWM voltage exceeds 2.7V,  $V_{PWM}$  uses 2.7V to calculate the  $V_{FB}$ . The PWM frequency is recommended above 15KHz. The LED current ( $I_{LED}$ ) is calculated using formula as below.

$$V_{FB} = \frac{V_{PWM} \times Duty - 0.2V}{10}, \quad I_{LED} = \frac{V_{FB}}{R_S}$$

### FB Voltage Setting

The DIM connects to input voltage through resistance 200kΩ when applications don't need to dimming control. The FB voltage fixes in 0.25V. The DIM pin can't float in normal operation.

### Over Voltage Protection

Use a resistive divider between LED+ and OVP pin to set overvoltage threshold limit. The EXT signal is always turned off when OVP is greater than 0.7V. OVP is lower than 0.7V then EXT signal is turned on immediately, the hysteresis voltage doesn't exist. The voltage ( $V_{OVP}$ ) can be calculated using following formula.

$$V_{OVP} = 0.7V \times \left\langle 1 + \frac{R11}{R12} \right\rangle$$

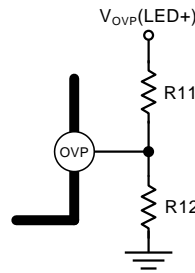

### Thermal Shutdown Protection

The IC will shut down automatically when the internal junction temperature exceeds +150°C. The device can restart until the junction temperature drops below +120°C approximately.

## Application Information

### Inductor Selection

The Inductance value is decided based on different condition. 4.7μH to 68uH inductance value is recommended for general application circuit. There are three important inductor specifications, DC resistance, saturation current and core loss. Low DC resistance has better power efficiency. The inductance is calculated using formula. Where  $V_{out}$  is LED string voltage,  $F_s$  is switching frequency,  $I_{out}$  is LED maximum current,  $Eff$  is boost efficiency and  $r$  is the ratio of the inductor peak-to-peak ripple current to the average DC inductor current at full load current.  $r$  is recommended between 0.3 and 0.5.

$$L = \left\langle \frac{V_{in}}{V_{out}} \right\rangle^2 \times \left\langle \frac{V_{out} - V_{in}}{F_s \times I_{out(max)}} \right\rangle \times \left\langle \frac{Eff}{r} \right\rangle$$

### Capacitor Selection

The output capacitor is required to maintain the DC voltage during switching. Low ESR capacitors are preferred to reduce the output voltage ripple. Ceramic capacitor of X5R and X7R are recommended, which have low equivalent series resistance (ESR) and wider operation temperature range.

### Diode Selection

Schottky diodes with fast recovery times and low forward voltages are recommended. Ensure the diode average and peak current rating exceed the average output current and peak inductor current. In addition, the diode's reverse breakdown voltage must exceed the output voltage.

This datasheet contains new product information. Advanced Analog Technology reserves the rights to modify the product specification without notice. No liability is assumed as a result of the use of this product. No rights under any patent accompany the sales of the product.

## LED Current Programming

The LED current is set by a resistor from the FB pin to ground. The LED current is:

$$I_{LED} = \frac{V_{FB}}{R_S}$$

## Layout Considerations

1. The power traces, consisting of the GND trace, the Q2 MOS drain to  $R_{CS}$  trace,  $V_{IN}$  and  $V_{OUT}$  trace should be kept short, direct and wide.
2. Layout switching node Q2 MOS drain, inductor and schottky diode connection traces wide and short to reduce EMI.
3. Place C6 nearby HVDD as closely as possible to maintain input voltage steady and filter noise.
4. The sense resistor  $R_S$  must be connected between FB and GND pin as closely as possible.
5. FB is a sensitive node. Please keep it away from switching node, Q2 MOS drain.
6. R11 and R12 must be connected close to OVP and GND pin.
7.  $R_{CS}$  must be connected close to CS and GND pin.
8. Output capacitor C7, C8 should be connected close and together directly to the ground of  $R_{CS}$ .
9. The GND of the  $R_{CS}$ , C1, C2, C7 and C8 should be connected close and together directly to a ground plane.

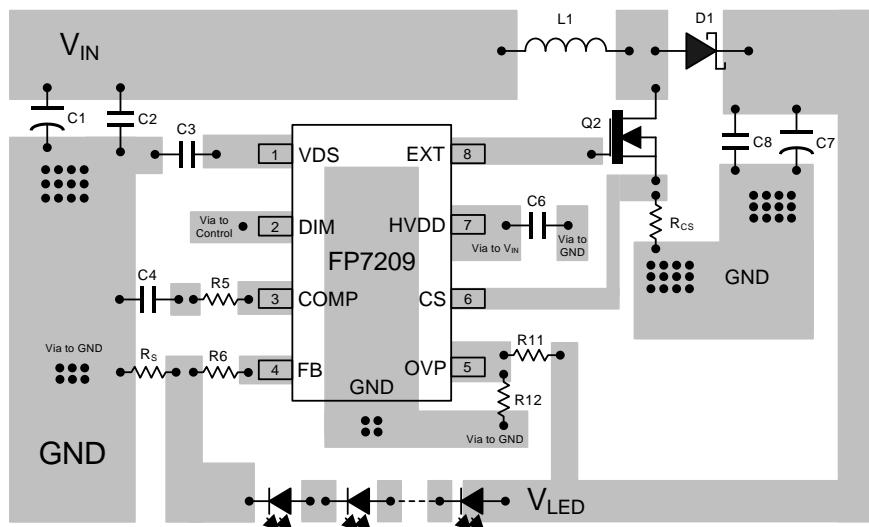

**Suggested Layout**

## Typical Application

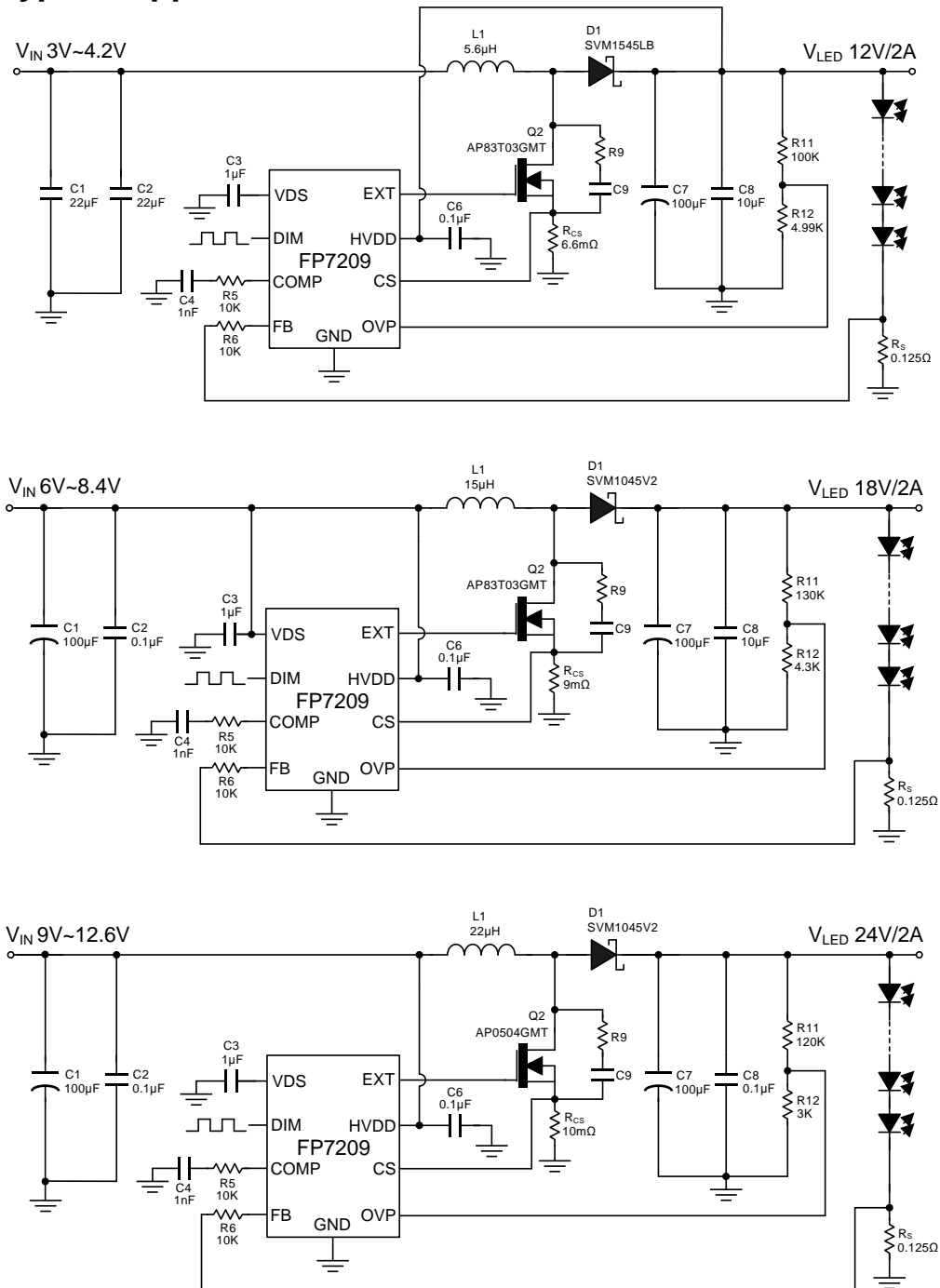

### Note:

1. The X5R and X7R of ceramic capacitors are recommended to choose.
2. R9 and C9 are added for reducing EMI (Electromagnetic Interference).
3. Don't control FB pin to adjust LED current when  $V_{IN}$  is less than 5V. Dimming controls DIM pin the initial PWM duty cycle is over 13% (LED Current 6%) if  $V_{IN}$  is less than 5V.

This datasheet contains new product information. Advanced Analog Technology reserves the rights to modify the product specification without notice. No liability is assumed as a result of the use of this product. No rights under any patent accompany the sales of the product.

## Package Outline

### SOP-8L (EP)

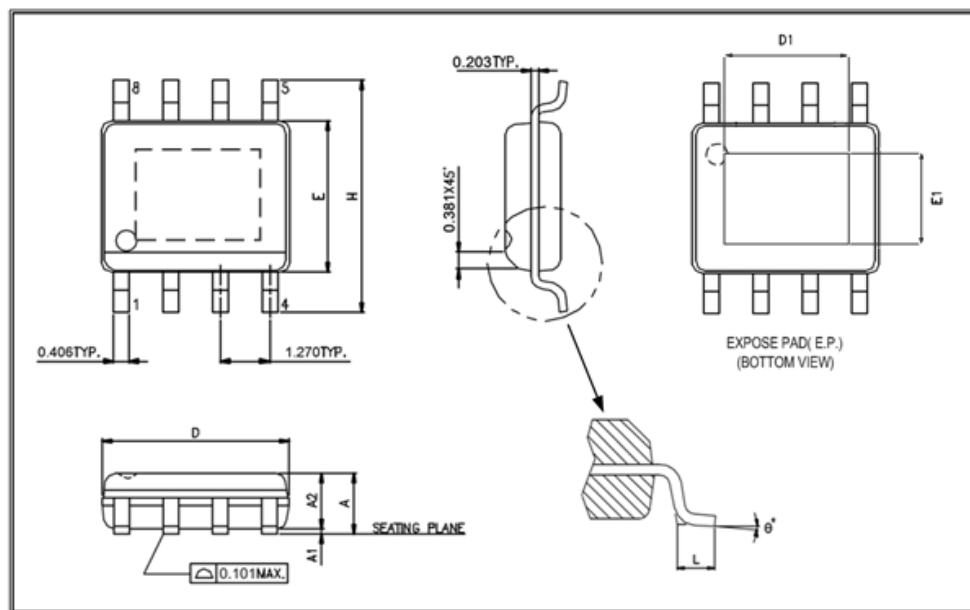
**UNIT: mm**

Symbols	Min. (mm)	Max. (mm)
A	1.30	1.70
A1	0	0.15
A2	1.25	1.55
D	4.70	5.10
E	3.80	4.00
H	5.80	6.20
L	0.40	1.27

#### Exposed PAD Dimensions:

Symbols	Min. (mm)	Max. (mm)
D1	2.60	3.45
E1	1.90	2.56

#### Note:

1. Package dimensions are in compliance with JEDEC outline: MS-012 AA.
2. Dimension "D" does not include molding flash, protrusions or gate burrs.
3. Dimension "E" does not include inter-lead flash or protrusions.