

8925E SERIES

1.27mm PITCH LOW PROFILE CONNECTORS FOR 0.635MM PITCH FLAT CABLE

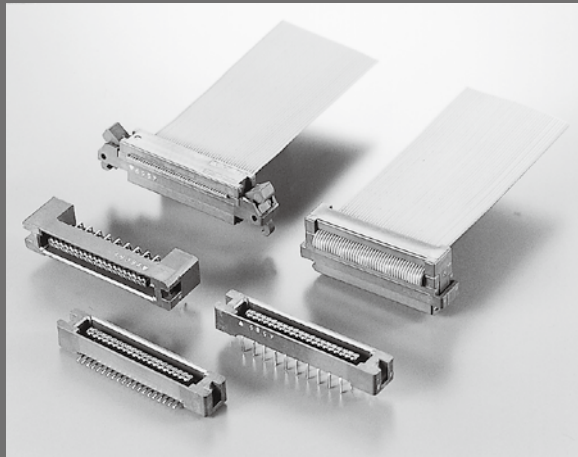

FEATURES

- ▶ Highly reliable contact design with independent and synchronized spring.
- ▶ Low insertion and withdrawal force.
- ▶ Insulator protects contacts from damage.
- ▶ Mating height is only 11.8mm(0.465") (8925R).
- ▶ Ability to make "daisy chain" cable assemblies.
- ▶ Cable connector (Receptacle) is able to mate with 8913 series (8925 series: non ejector type).
- ▶ Connectors with the Eject-Lock mechanism, allowing one-handed insertion and release. (8925E and 8925R series).
- ▶ PCB side connector variations: Straight, Right angle and SMT.

ORDER CODE

8925 - - **179** - **F**

①
 ②
 ③
 ④

*Please order in multiples of the quantity per package.

① **[Type]** Receptacle (Cable side connector) **8925** : Non ejector type, With strain relief (excl. 20, 30, 60 pins)
8925E : Ejector type, With strain relief **8925R** : Ejector type, Without strain relief

② **[Number of contacts]** **020** : 20pin **030** : 30pin **040** : 40pin **050** : 50pin **060** : 60pin **068** : 68pin **080** : 80pin **100** : 100pin

③ **[Contact name]** **179**

④ **[RoHS]** **F** : RoHS Compliant

ORDER CODE

893 **E** - - **178** - **F**

①
 ②
 ③
 ④
 ⑤

*Please order in multiples of the quantity per package.

① **[Type]** Plug (PCB side connector) **8930E** : Without hooks (SMT) **8931E** : With hooks (Through hole)

② **[Number of contacts]** **020** : 20pin **030** : 30pin **040** : 40pin **050** : 50pin **060** : 60pin **068** : 68pin **080** : 80pin **100** : 100pin

③ **[Contact name]** **178**

④ **[Contact tail style]** **S** : Straight, Through hole **L** : Right angle, Through hole **MS** : Straight, SMT (8930E)

⑤ **[RoHS]** **F** : RoHS Compliant

SPECIFICATIONS

Material and plating		Electrical Characteristics	
Insulator material	[8925E/8925R/8925]	Current rating	0.5A per contact
	Glass-filled Nylon 66 (UL 94V-0), Brown	Contact resistance	40mΩ max.
	[8930E/8931E] Glass-filled PPS (UL 94V-0), Brown	Dielectric withstanding voltage	[8925]300V AC for 1 minute [893 E]650V AC for 1 minute
Contact material	Copper alloy	Insulation resistance	[8925]1,000MΩ min. at 250V DC [893 E]1,000MΩ min. at 500V DC
Contact plating	Gold over Nickel	Operating temperature	-55°C to +85°C
Retention clip material	Copper alloy	Recommended cable	#30 AWG (7/0.102), 0.635mm (25mil) pitch, Flat ribbon cable
Retention clip plating	Tin copper over Nickel		

Low-profile design

Unit : mm(inch)

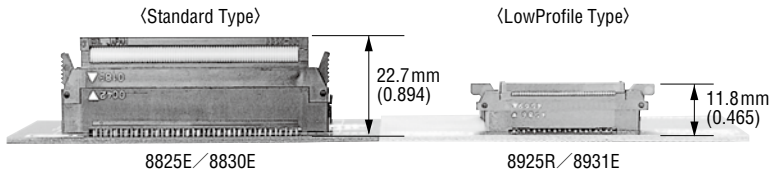

The 8925(E/R) series uses the same proven contact design as the 8900 series of board-to-board connectors. In addition, this low profile IDC connector system features a new locking ejector mechanism. The 8925R/8930E series has a mated height of 11.8mm which is significantly less than previous IDC connector systems. (KEL 8825E/8830E series)

Mating Drawing

Unit : mm(inch)

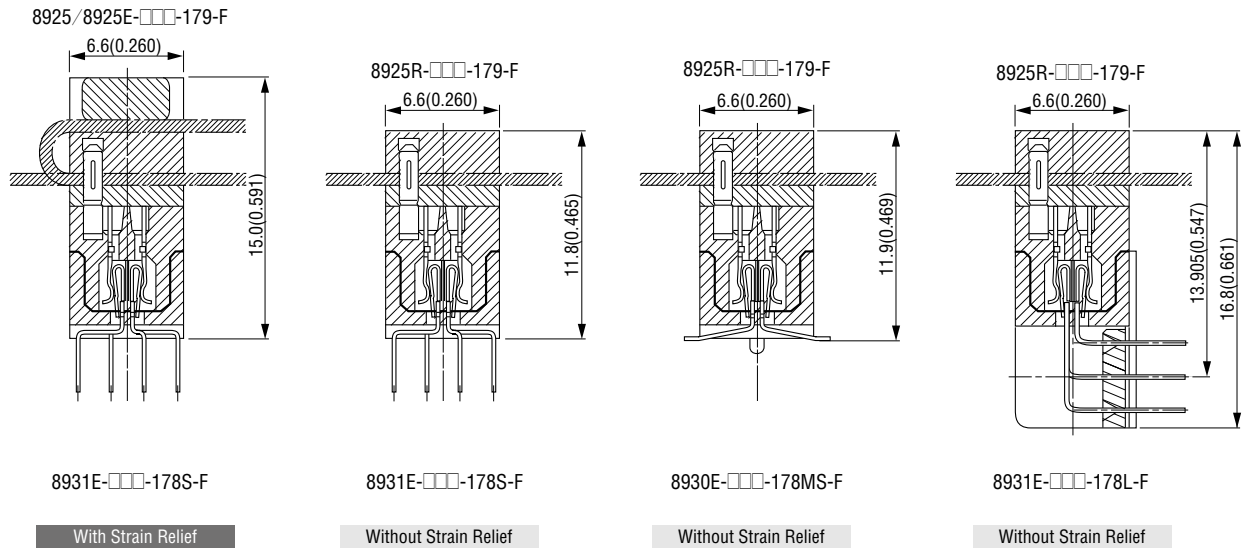

8925E Series Mating Matrix

PLUG CONNECTOR	RECEPTACLE CONNECTOR		
	8925-□□□-179-F	8925E-□□□-179-F	8925R-□□□-179-F
8911-□□□-178S□-A-F	No	No	No
8911-□□□-178S□-C-F	No	No	No
8913-□□□-178S□-A-F	△ Mated height : 15.0(0.591)	No	No
8913-□□□-178S□-C-F	△ Mated height : 17.0(0.669)	No	No
8911-□□□-178L□-F	No	No	No
8913-□□□-178MS□-A-F	△ Mated height : 15.0(0.591)	No	No
8931E-□□□-178S-F	○ Mated height : 15.0(0.591)	○ Mated height : 15.0(0.591)	○ Mated height : 11.8(0.465)
8931E-□□□-178L-F	○ Mated distance : 20.0(0.787)	○ Mated distance : 20.0(0.787)	○ Mated distance : 16.8(0.661)
8930E-□□□-178MS-F	○ Mated height : 15.1(0.594)	○ Mated height : 15.1(0.594)	○ Mated height : 11.9(0.469)

Note: △ excl. 68 pin.

Product Concept and Features

Highly reliable and original termination form

The terminating process of 8925E series starts with the flat cable of 0.635mm pitch placed between Covers #1 and #2 which aligns and prevents any deviation between the cable and connector.

The contacts are held in position by the insulator body.

The tips of the contact forks with guide taper and latch sharp and break through the cable sheath to provide a gas tight termination.

The contact rib which is purposely rounded creates high pressure to insure a reliable termination without damage during the termination process.

The connector can be terminated with a minimum of special tooling in a standard press as well as a press for MIL-STD type connectors.

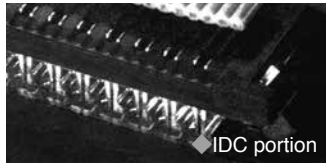

◆ Exploded View

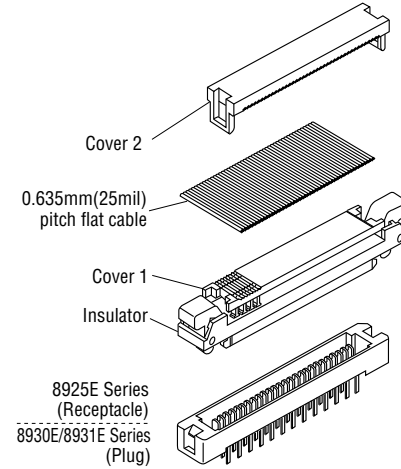

◆ 8925(E) Series contact

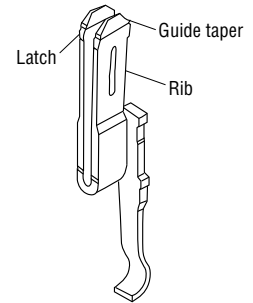

◆ Insulation Displacement Process

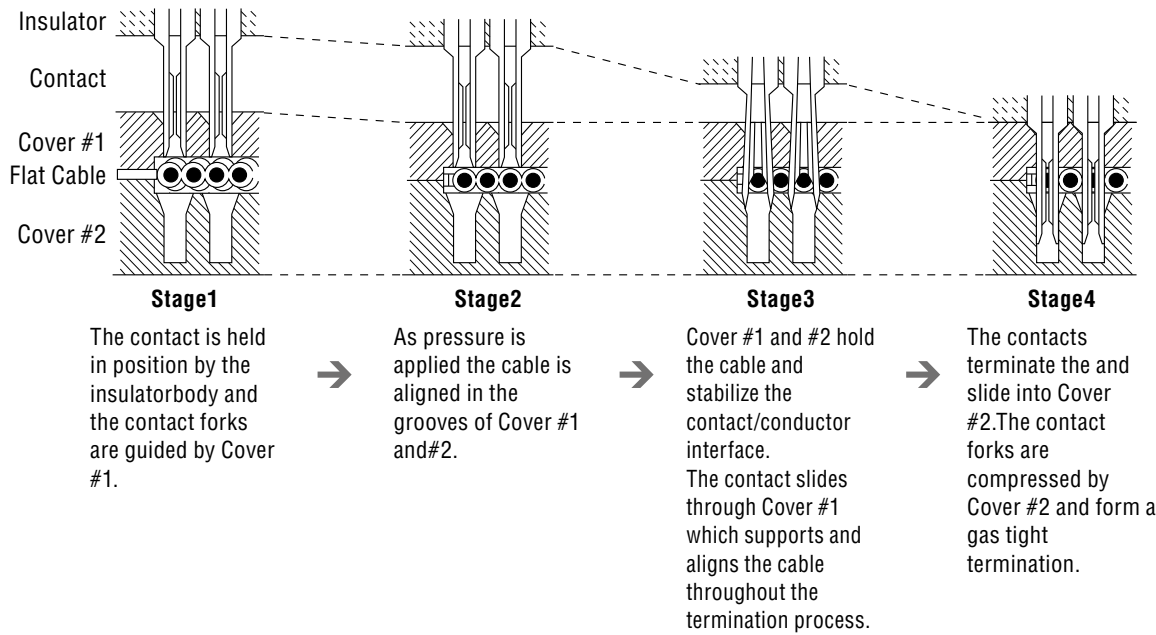

→ The reliability of the termination process depends on maintaining proper alignment of the cable to the connector, the contact to the conductor, and the stability of contact in the connector. The design of the 8925(E) satisfies the requirements as explained above.

8925-□□□-179-F (Receptacle, Cable side connector, Without locking ejectors)

Unit : mm(inch)

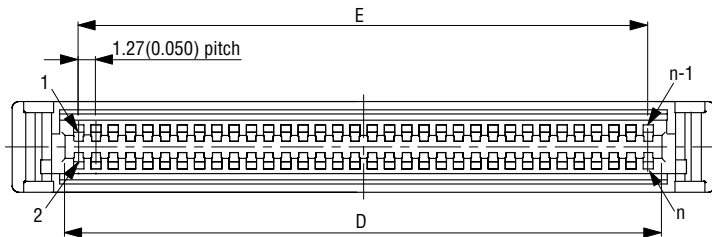
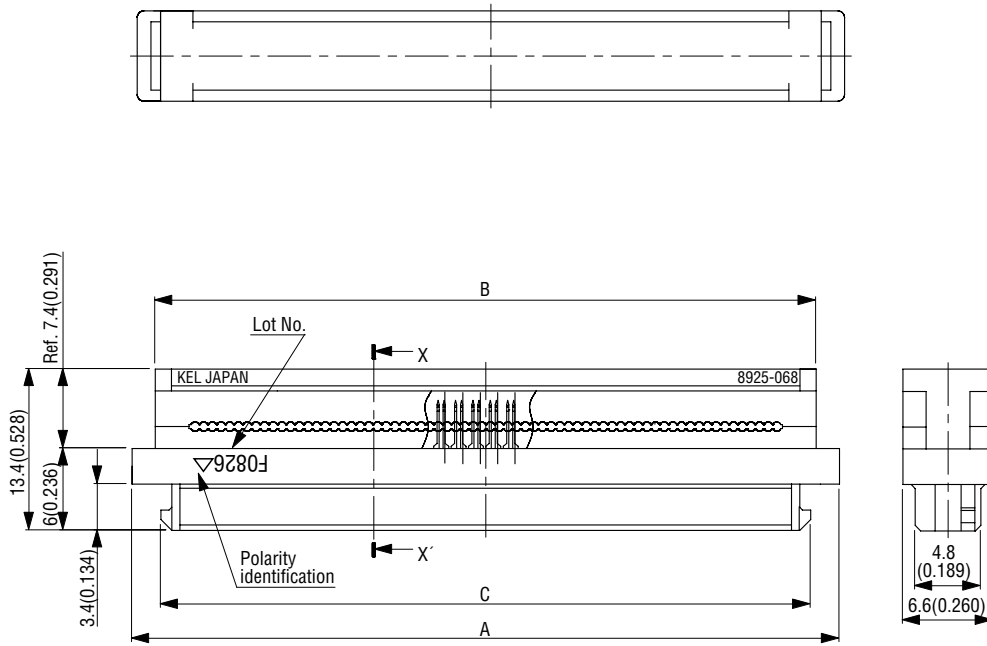

X-X' Cross Section

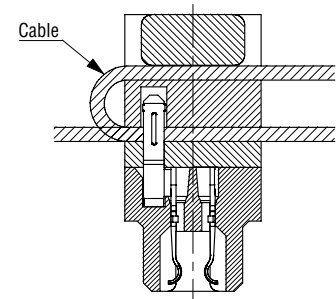

Packaging style

Pipe

► **Product Table / Dimensions**

No. of contacts	Part Number	A	B	C	D	E	Number of packaging
40	8925-040-179-F	33.93 (1.336)	30.53 (1.202)	29.73 (1.170)	26.13 (1.029)	24.13 (0.950)	15
50	8925-050-179-F	40.28 (1.586)	36.88 (1.452)	36.08 (1.420)	32.48 (1.279)	30.48 (1.200)	12
68	8925-068-179-F	51.71 (2.036)	48.31 (1.902)	47.51 (1.870)	43.91 (1.729)	41.91 (1.650)	10
80	8925-080-179-F	59.33 (2.336)	55.93 (2.202)	55.13 (2.170)	51.53 (2.029)	49.53 (1.950)	8
100	8925-100-179-F	72.03 (2.836)	68.63 (2.702)	67.83 (2.670)	64.23 (2.529)	62.23 (2.450)	7

8925E/8925R-□□□-179-F (Receptacle, Cable side connector, With locking ejectors)

Unit : mm(inch)

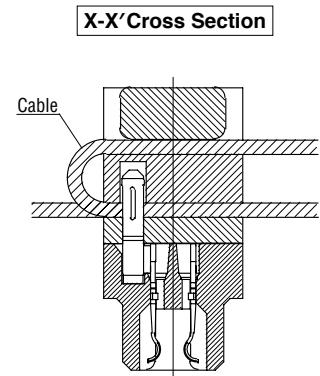
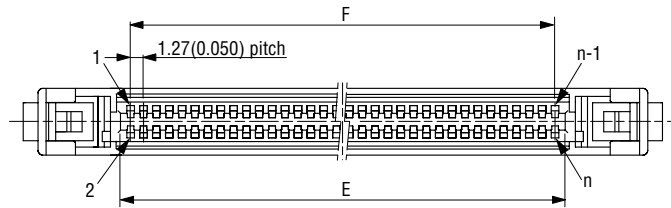
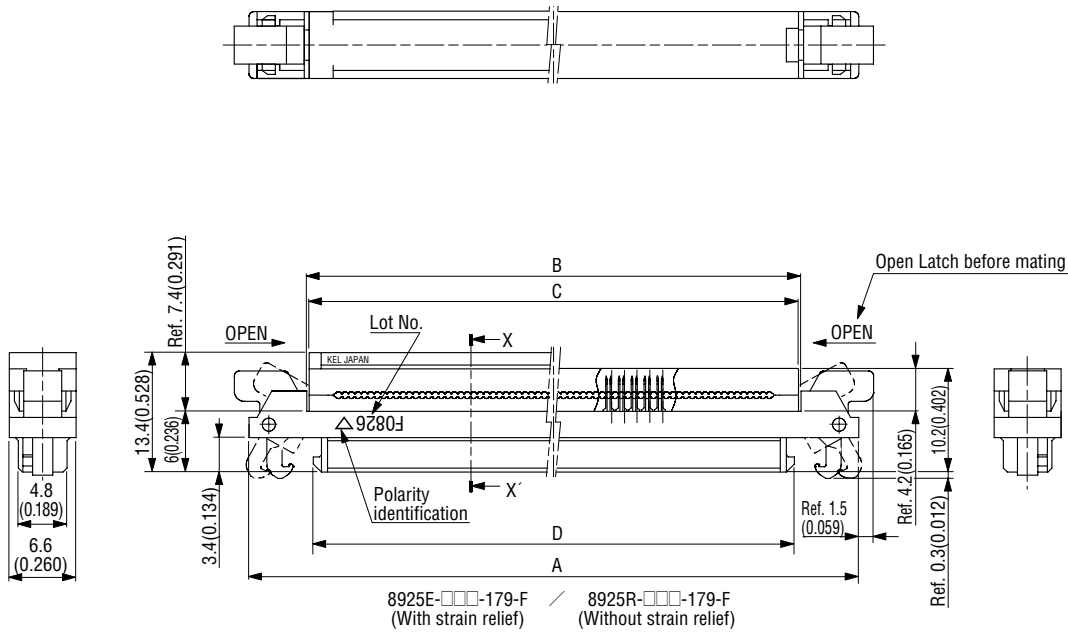

Packaging style
Pipe

Product Table / Dimensions

No. of contacts	Part Number	A	B	C	D	E	F	Number of packaging
20	8925E-020-179-F 8925R-020-179-F	29.63 (1.167)	18.23 (0.718)	17.83 (0.702)	17.03 (0.670)	13.43 (0.529)	11.43 (0.450)	15
30	8925E-030-179-F 8925R-030-179-F	35.98 (1.417)	24.58 (0.968)	24.18 (0.952)	23.38 (0.920)	19.78 (0.779)	17.78 (0.700)	13
40	8925E-040-179-F 8925R-040-179-F	42.33 (1.667)	30.93 (1.218)	30.53 (1.202)	29.73 (1.170)	26.13 (1.029)	24.13 (0.950)	11
50	8925E-050-179-F 8925R-050-179-F	48.68 (1.917)	37.28 (1.468)	36.88 (1.452)	36.08 (1.420)	32.48 (1.279)	30.48 (1.200)	10
60	8925E-060-179-F 8925R-060-179-F	55.03 (2.167)	43.63 (1.718)	43.23 (1.702)	42.43 (1.670)	38.83 (1.529)	36.83 (1.450)	8
68	8925E-068-179-F 8925R-068-179-F	60.11 (2.367)	48.71 (1.918)	48.31 (1.902)	47.51 (1.870)	43.91 (1.729)	41.91 (1.650)	8
80	8925E-080-179-F 8925R-080-179-F	67.73 (2.667)	56.33 (2.218)	55.93 (2.202)	55.13 (2.170)	51.53 (2.029)	49.53 (1.950)	7
100	8925E-100-179-F 8925R-100-179-F	80.43 (3.167)	69.03 (2.718)	68.63 (2.702)	67.83 (2.670)	64.23 (2.529)	62.23 (2.450)	6

8931E-□□□-178S-F (Plug, PCB side connector, Straight)

Unit : mm(inch)

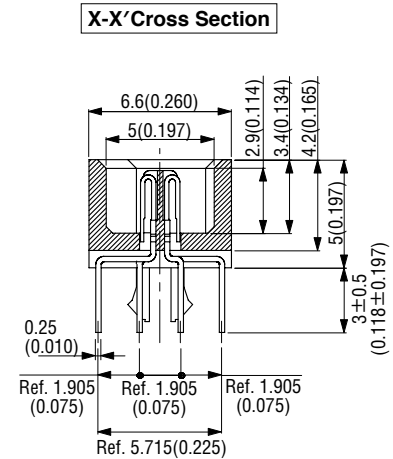
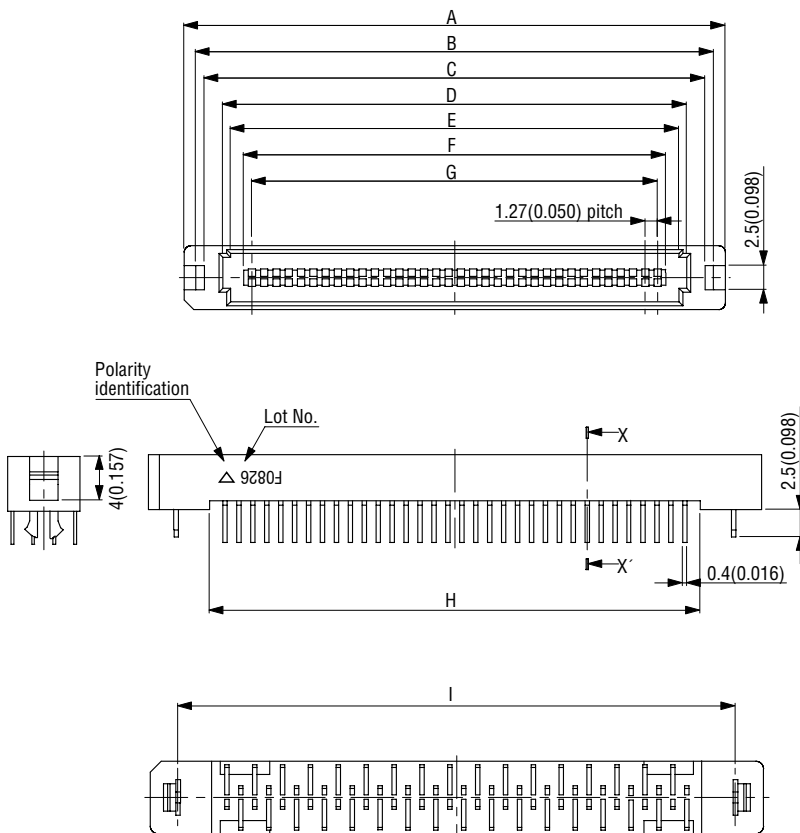
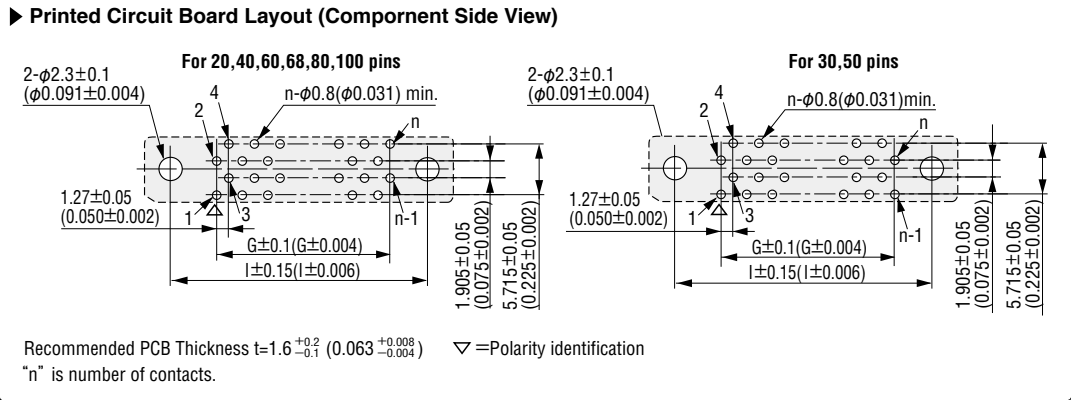

Packaging style
Pipe

Product Table / Dimensions

No. of contacts	Part Number	A	B	C	D	E	F	G	H	I	Number of packaging
20	8931E-020-178S-F	25.43 (1.001)	23.03 (0.907)	21.23 (0.836)	17.43 (0.686)	15.83 (0.623)	13.13 (0.517)	11.43 (0.450)	14.23 (0.560)	20.32 (0.800)	20
30	8931E-030-178S-F	31.78 (1.251)	29.38 (1.157)	27.58 (1.086)	23.78 (0.936)	22.18 (0.873)	19.48 (0.767)	17.78 (0.700)	20.58 (0.810)	26.67 (1.050)	16
40	8931E-040-178S-F	38.13 (1.501)	35.73 (1.407)	33.93 (1.336)	30.13 (1.186)	28.53 (1.123)	25.83 (1.017)	24.13 (0.950)	26.93 (1.060)	33.02 (1.300)	13
50	8931E-050-178S-F	44.48 (1.751)	42.08 (1.657)	40.28 (1.586)	36.48 (1.436)	34.88 (1.373)	32.18 (1.267)	30.48 (1.200)	33.28 (1.310)	39.37 (1.550)	11
60	8931E-060-178S-F	50.83 (2.001)	48.43 (1.907)	46.63 (1.836)	42.83 (1.686)	41.23 (1.623)	38.53 (1.517)	36.83 (1.450)	39.63 (1.560)	45.72 (1.800)	10
68	8931E-068-178S-F	55.91 (2.201)	53.51 (2.107)	51.71 (2.036)	47.91 (1.886)	46.31 (1.823)	43.61 (1.717)	41.91 (1.650)	44.71 (1.760)	50.80 (2.000)	9
80	8931E-080-178S-F	63.53 (2.501)	61.13 (2.407)	59.33 (2.336)	55.53 (2.186)	53.93 (2.123)	51.23 (2.017)	49.53 (1.950)	52.33 (2.060)	58.42 (2.300)	7
100	8931E-100-178S-F	76.23 (3.001)	73.83 (2.907)	72.03 (2.836)	68.23 (2.686)	66.63 (2.623)	63.93 (2.517)	62.23 (2.450)	65.03 (2.560)	71.12 (2.800)	6

4006-022-002

shunto@126.com

8931E-□□□-178L-F (Plug, PCB side connector, Right angle)

Unit : mm(inch)

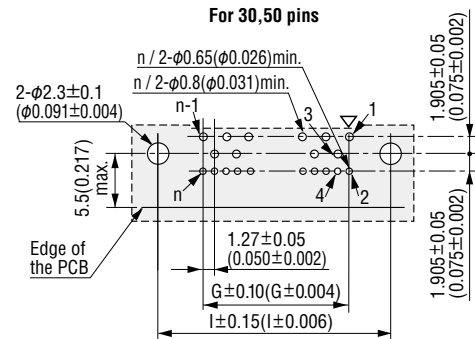
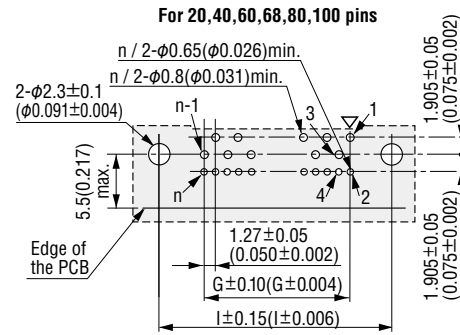
Printed Circuit Board Layout (Component Side View)

Recommended PCB Thickness $t = 1.6^{+0.2}_{-0.1}$ (0.063^{+0.008}_{-0.004}) ▽ = Polarity identification
 "n" is number of contacts.

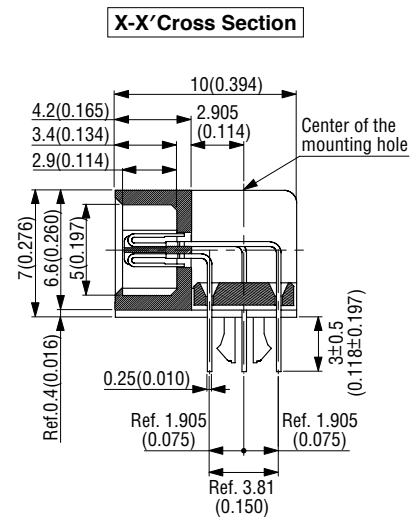
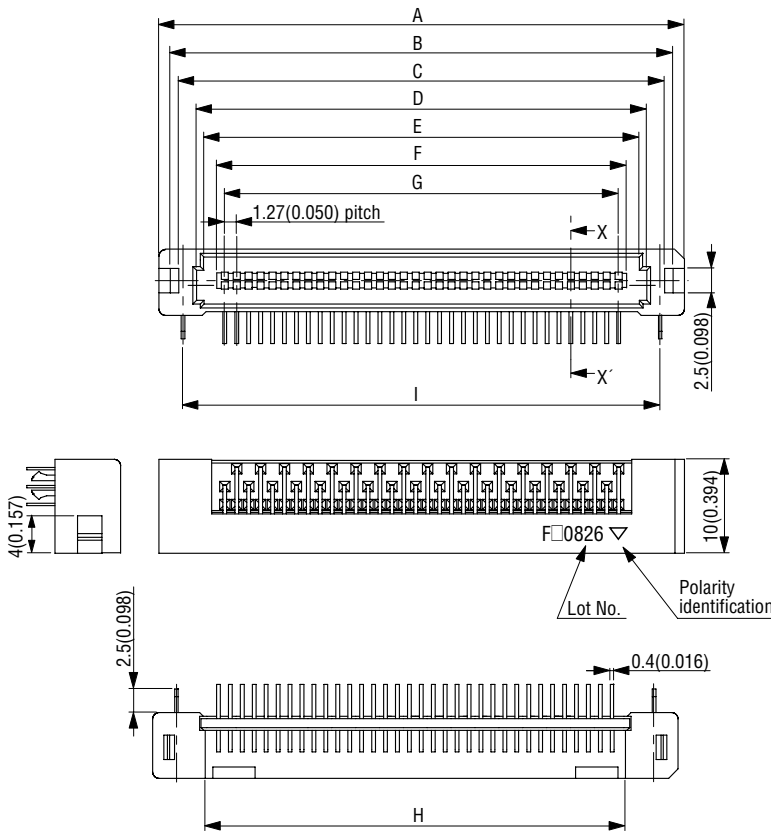

Packaging style
Pipe

Product Table / Dimensions

No. of contacts	Part Number	A	B	C	D	E	F	G	H	I	Number of packaging
20	8931E-020-178L-F	25.43 (1.001)	23.03 (0.907)	21.23 (0.836)	17.43 (0.686)	15.83 (0.623)	13.13 (0.517)	11.43 (0.450)	14.23 (0.560)	20.32 (0.800)	20
30	8931E-030-178L-F	31.78 (1.251)	29.38 (1.157)	27.58 (1.086)	23.78 (0.936)	22.18 (0.873)	19.48 (0.767)	17.78 (0.700)	20.58 (0.810)	26.67 (1.050)	16
40	8931E-040-178L-F	38.13 (1.501)	35.73 (1.407)	33.93 (1.336)	30.13 (1.186)	28.53 (1.123)	25.83 (1.017)	24.13 (0.950)	26.93 (1.060)	33.02 (1.300)	13
50	8931E-050-178L-F	44.48 (1.751)	42.08 (1.657)	40.28 (1.586)	36.48 (1.436)	34.88 (1.373)	32.18 (1.267)	30.48 (1.200)	33.28 (1.310)	39.37 (1.550)	11
60	8931E-060-178L-F	50.83 (2.001)	48.43 (1.907)	46.63 (1.836)	42.83 (1.686)	41.23 (1.623)	38.53 (1.517)	36.83 (1.450)	39.63 (1.560)	45.72 (1.800)	10
68	8931E-068-178L-F	55.91 (2.201)	53.51 (2.107)	51.71 (2.036)	47.91 (1.886)	46.31 (1.823)	43.61 (1.717)	41.91 (1.650)	44.71 (1.760)	50.80 (2.000)	9
80	8931E-080-178L-F	63.53 (2.501)	61.13 (2.407)	59.33 (2.336)	55.53 (2.186)	53.93 (2.123)	51.23 (2.017)	49.53 (1.950)	52.33 (2.060)	58.42 (2.300)	8
100	8931E-100-178L-F	76.23 (3.001)	73.83 (2.907)	72.03 (2.836)	68.23 (2.686)	66.63 (2.623)	63.93 (2.517)	62.23 (2.450)	65.03 (2.560)	71.12 (2.800)	6

4006-022-002

shunto@126.com

8930E-□□□-178MS-F (Plug, PCB side connector, Straight, SMT)

Unit : mm(inch)

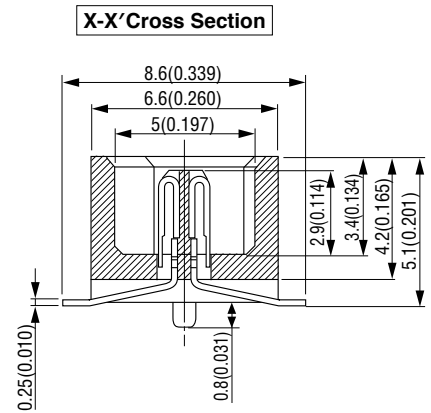
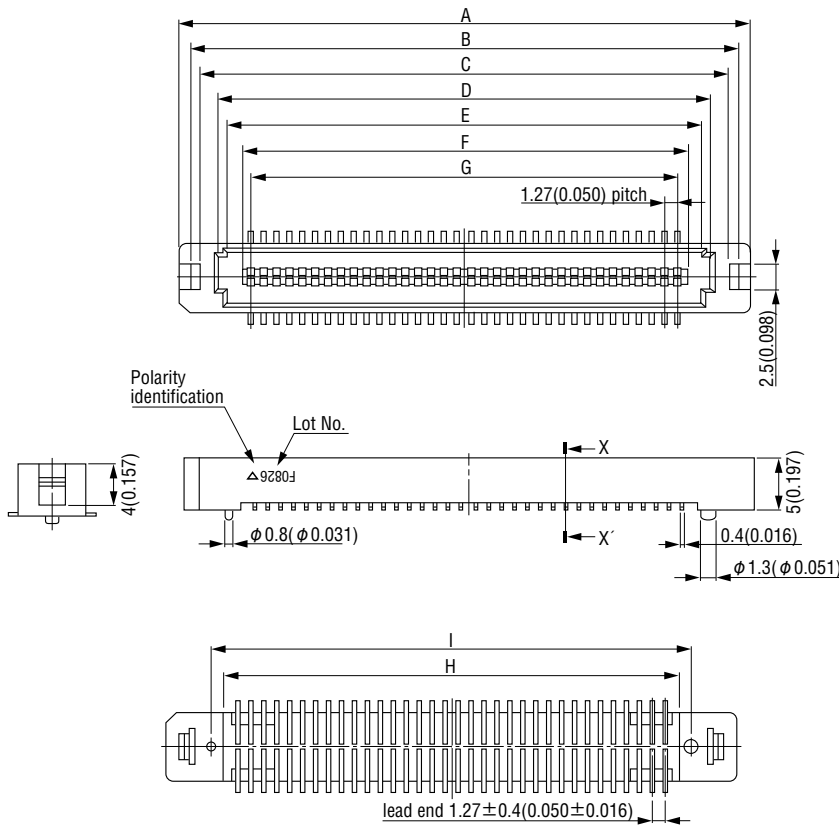
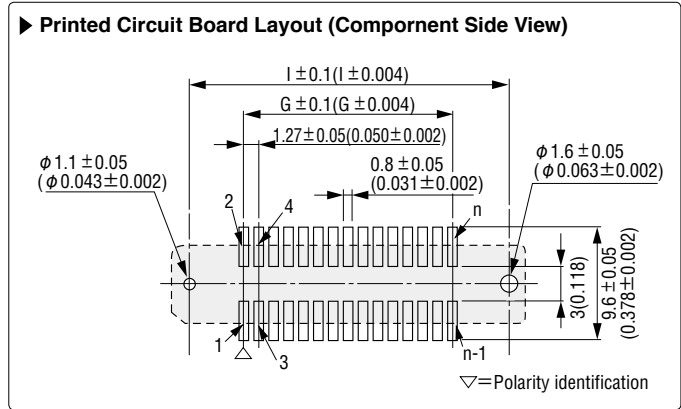

Packaging style
Pipe

► Product Table / Dimensions

No. of contacts	Part Number	A	B	C	D	E	F	G	H	I	Number of packaging
20	8930E-020-178MS-F	25.43 (1.001)	23.03 (0.907)	21.23 (0.836)	17.43 (0.686)	15.83 (0.623)	13.13 (0.517)	11.43 (0.450)	14.23 (0.560)	16.51 (0.650)	20
30	8930E-030-178MS-F	31.78 (1.251)	29.38 (1.157)	27.58 (1.086)	23.78 (0.936)	22.18 (0.873)	19.48 (0.767)	17.78 (0.700)	20.58 (0.810)	22.86 (0.900)	16
40	8930E-040-178MS-F	38.13 (1.501)	35.73 (1.407)	33.93 (1.336)	30.13 (1.186)	28.53 (1.123)	25.83 (1.017)	24.13 (0.950)	26.93 (1.060)	29.21 (1.150)	13
50	8930E-050-178MS-F	44.48 (1.751)	42.08 (1.657)	40.28 (1.586)	36.48 (1.436)	34.88 (1.373)	32.18 (1.267)	30.48 (1.200)	33.28 (1.310)	35.56 (1.400)	11
60	8930E-060-178MS-F	50.83 (2.001)	48.43 (1.907)	46.63 (1.836)	42.83 (1.686)	41.23 (1.623)	38.53 (1.517)	36.83 (1.450)	39.63 (1.560)	41.91 (1.650)	10
68	8930E-068-178MS-F	55.91 (2.201)	53.51 (2.107)	51.71 (2.036)	47.91 (1.886)	46.31 (1.823)	43.61 (1.717)	41.91 (1.650)	44.71 (1.760)	46.99 (1.850)	9
80	8930E-080-178MS-F	63.53 (2.501)	61.13 (2.407)	59.33 (2.336)	55.53 (2.186)	53.93 (2.123)	51.23 (2.017)	49.53 (1.950)	52.33 (2.060)	54.61 (2.150)	8
100	8930E-100-178MS-F	76.23 (3.001)	73.83 (2.907)	72.03 (2.836)	68.23 (2.686)	66.63 (2.623)	63.93 (2.517)	62.23 (2.450)	65.03 (2.560)	67.31 (2.650)	6

4006-022-002

shunto@126.com

CABLE ASSEMBLY
ORDER CODE

8925 - - **179 F** - - - - -
 ① ② ③ ④ ⑤ ⑥ ⑦

- ① **[Type]** Receptacle, With strain relief
8925 : Without locking ejectors **8925E** : With locking ejectors
- ② **[No. of contacts]** **020** : 20pin **030** : 30pin **040** : 40pin **050** : 50pin
060 : 60pin **068** : 68pin **080** : 80pin **100** : 100pin
 (8925 : excl. 20, 30 and 60 pins)
- ③ **[Contact name]** **179**
- ④ **[RoHS]** **F** : RoHS Compliant
- ⑤ **[Cable length (cm)]** **L** : dimension (Example: 013=13cm)
- ⑥ **[Cable type]** **Omit** : Flat cable
S : Intermittent bonded cable* **T** : Twist&Flat cable*
- ⑦ **[Wiring code]** **GG, GH, HH, GO, HO**

* If you are interested in the intermittent bonded or Twist&Flat cable, please contact your local KEL sales office.

ORDER CODE

8925R - - - - - **179 F** - - - - -
 ① ② ③ ④ ⑤ ⑥ ⑦

- ① **[Type]** Receptacle
8925R : With locking ejectors, Without strain relief
- ② **[No. of contacts]** **020** : 20pin **030** : 30pin **040** : 40pin **050** : 50pin
060 : 60pin **068** : 68pin **080** : 80pin **100** : 100pin
- ③ **[Contact name]** **179**
- ④ **[RoHS]** **F** : RoHS Compliant
- ⑤ **[Cable length (cm)]** **L** : dimension (Example: 013=13cm)
- ⑥ **[Cable type]** **Omit** : Flat cable
S : Intermittent bonded cable* **T** : Twist&Flat cable*
- ⑦ **[Wiring code]** **IJ, IJ, JJ, IO, JO**

* If you are interested in the intermittent bonded or Twist&Flat cable, please contact your local KEL sales office.

► 8925(E)-8925(E) Cable assemblies

Unit : mm(inch)

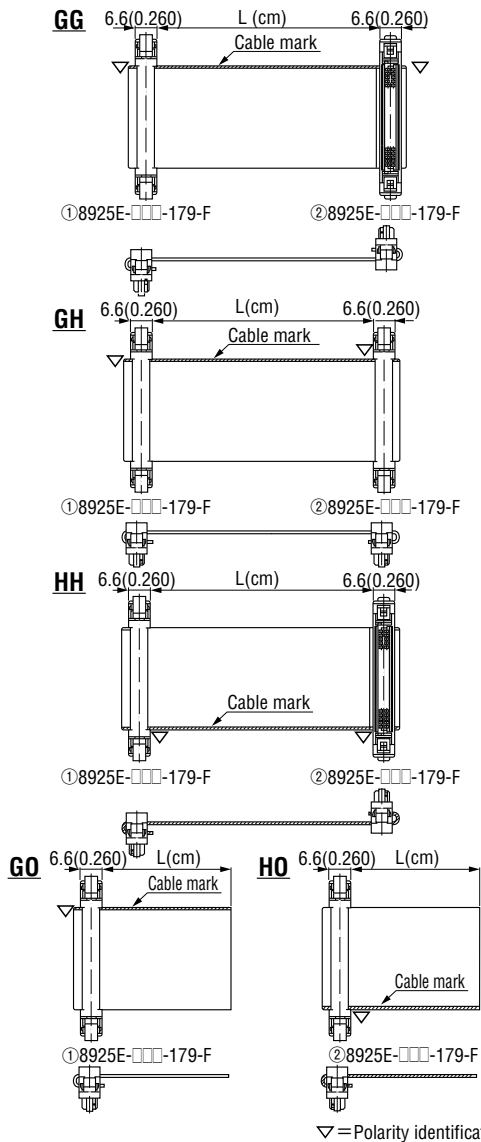
► 8925R-8925R Cable assemblies

Unit : mm(inch)

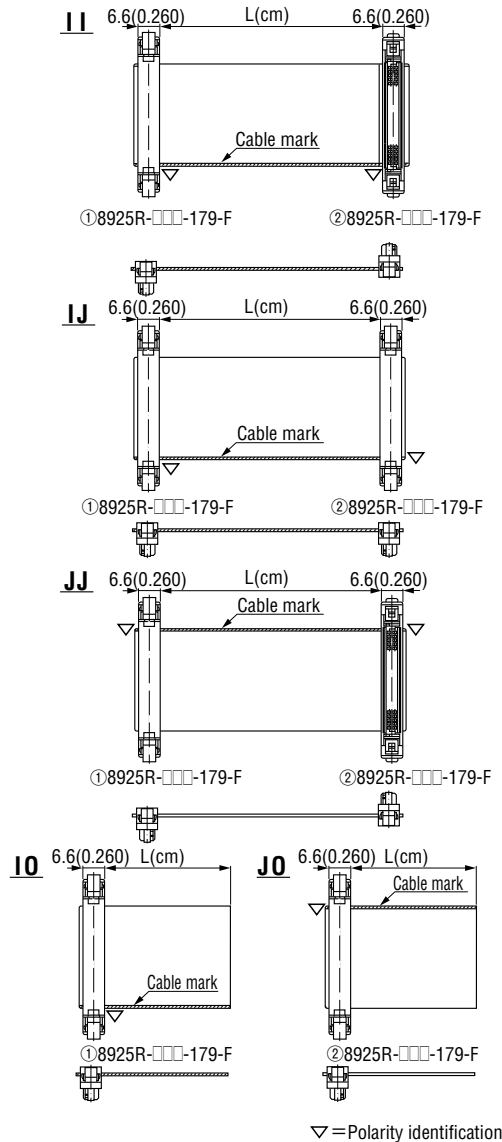

* Intermittent bonded and Twist&Flat cable have a restriction on cable length (L dimension) because they are terminated at the fused part.

* For GO, HO, IO and JO codes, orders are accepted in even quantities. * Harness end has an extra of approximate 1mm beyond the connector edge.

ORDER CODE

8925E- **-179 F-** **-**

① ② ③ ④ ⑤ ⑥ ⑦

- ① **[Type]** Receptacle, With strain relief **8925E** : With locking ejectors
- ② **[No. of contacts]** **020** : 20pin **030** : 30pin **040** : 40pin **050** : 50pin
060 : 60pin **068** : 68pin **080** : 80pin **100** : 100pin
- ③ **[Contact name]** **179**
- ④ **[RoHS]** **F** : RoHS Compliant
- ⑤ **[Cable length (cm)]** **L** : dimension (Example: 013=13cm)
- ⑥ **[Cable type]** **Omit** : Flat cable **S** : Intermittent bonded cable* **T** : Twist&Flat cable*
- ⑦ **[Wiring code]** **GI, GJ, HI, HJ**

* If you are interested in the intermittent bonded or Twist&Flat cable, please contact your local KEL sales office.

ORDER CODE

8925E- **-179 F-** **GZH**

① ② ③ ④ ⑤ ⑥ ⑦

- ① **[Type]** Receptacle, With strain relief **8925E** : With locking ejectors
- ② **[No. of contacts]** **020** : 20pin **030** : 30pin **040** : 40pin **050** : 50pin
060 : 60pin **068** : 68pin **080** : 80pin **100** : 100pin
- ③ **[Contact name]** **179**
- ④ **[RoHS]** **F** : RoHS Compliant
- ⑤ **[Cable length (cm)]** **L₁** : dimension (Example: 013=13cm)
- ⑥ **[Wiring code]** **GZH**
- ⑦ **[Cable length(cm)]** **L₂** : dimension (Example: 013=13cm)

► 8925E-8925R Cable assemblies

Unit : mm(inch)

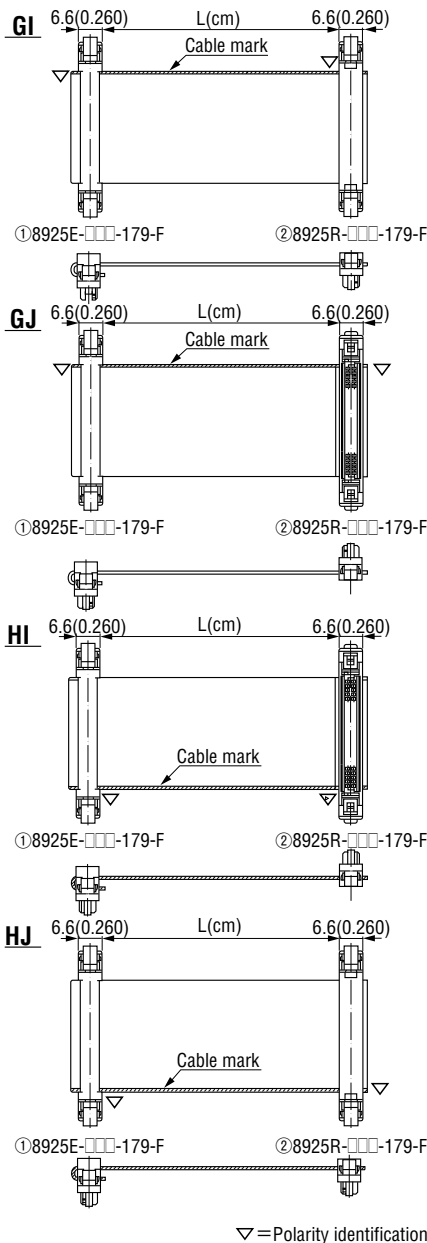

► Daisy chain assembly

Unit : mm(inch)

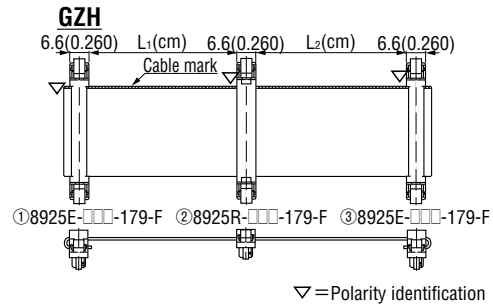

ORDER CODE

8925R- **-179 F-** **IZJ**

① ② ③ ④ ⑤ ⑥ ⑦

- ① **[Type]** Receptacle **8925R** : Without strain relief With locking ejectors
- ② **[No. of contacts]** **020** : 20pin **030** : 30pin **040** : 40pin **050** : 50pin
060 : 60pin **068** : 68pin **080** : 80pin **100** : 100pin
- ③ **[Contact name]** **179**
- ④ **[RoHS]** **F** : RoHS Compliant
- ⑤ **[Cable length (cm)]** **L₁** : dimension (Example: 013=13cm)
- ⑥ **[Wiring code]** **IZJ**
- ⑦ **[Cable length(cm)]** **L₂** : dimension (Example: 013=13cm)

* If you are interested in the intermittent bonded or Twist&Flat cable, please contact your local KEL sales office.

► Daisy chain assembly

Unit : mm(inch)

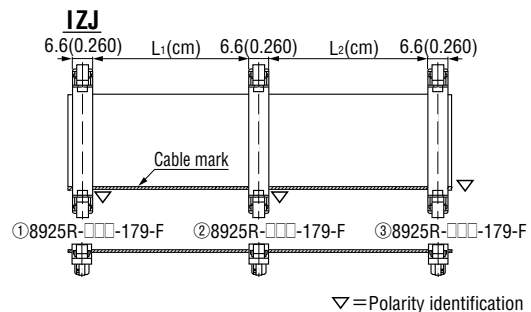

* Intermittent bonded and Twist&Flat cable have a restriction on cable length (L dimension) because they are terminated at the fused part.

* Harness end has an extra length of approximately 1mm beyond the connector edge.

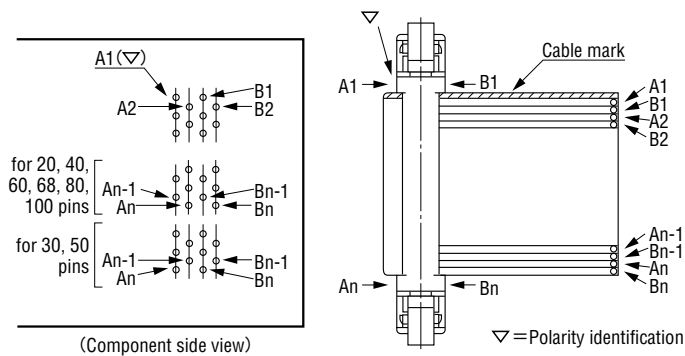
8925□/8931E SERIES PIN ASSIGNMENT (Straight, Through hole)
► Single end assembly (Example: GO wiring)

Note:
Please be careful when trimming the cable after terminating the 8925 □ Series, to protect against the flat ribbon cable that extends beyond the edge of the cable connector body touching the PCB and creating a short. (When used with Right angle Plug connector)

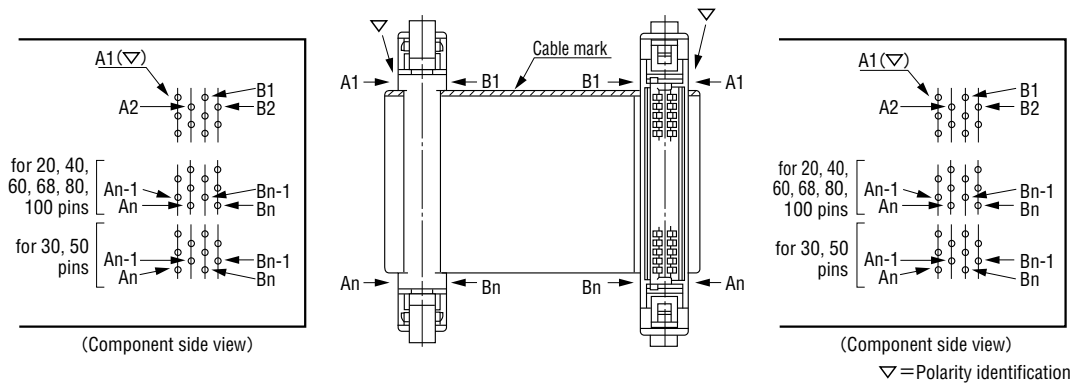
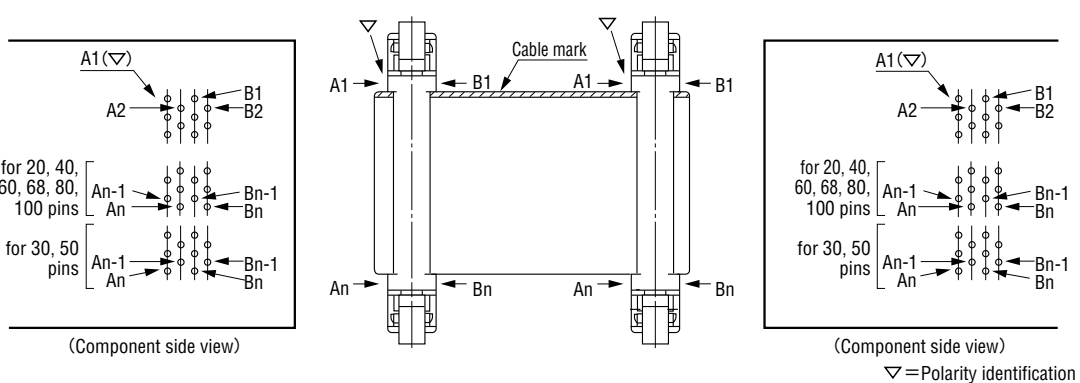
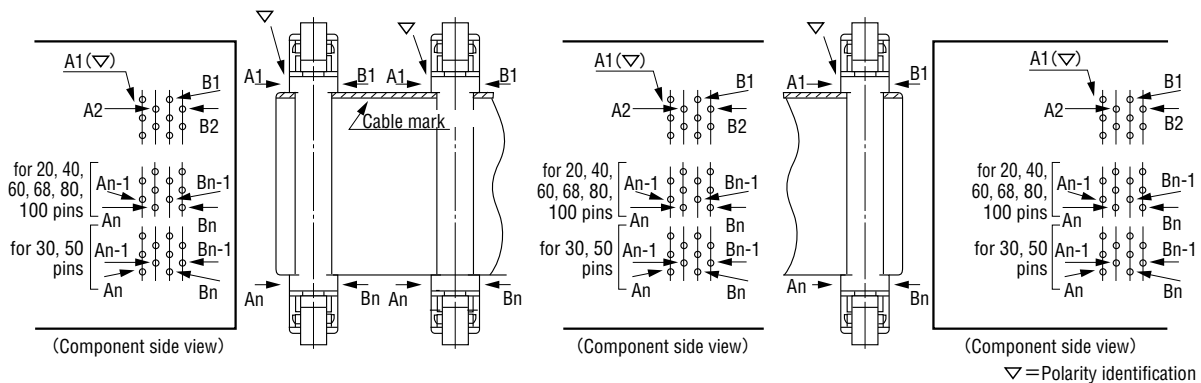
► Double end assembly (Example: GG wiring)

► Double end assembly (Example: GH wiring)

► Daisy chain assembly (Example: GZH wiring)

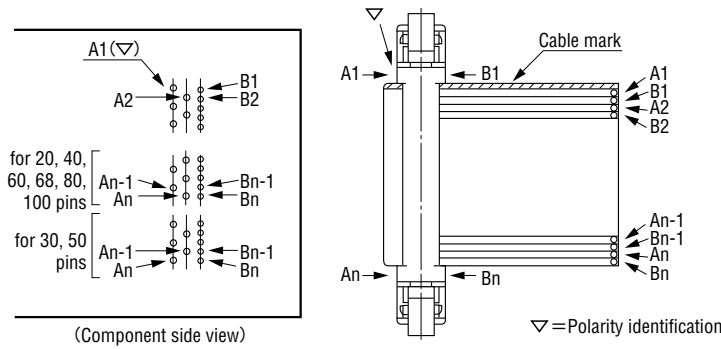
8925□/8931E SERIES PIN ASSIGNMENT (Right angle, Through hole)

► **Single end assembly (Example: GO wiring)**

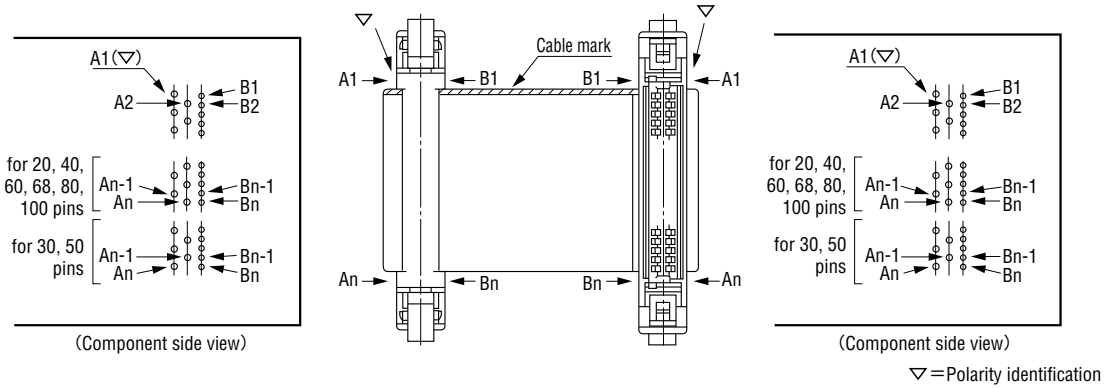

► **Double end assembly (Example: GG wiring)**



► **Double end assembly (Example: GH wiring)**

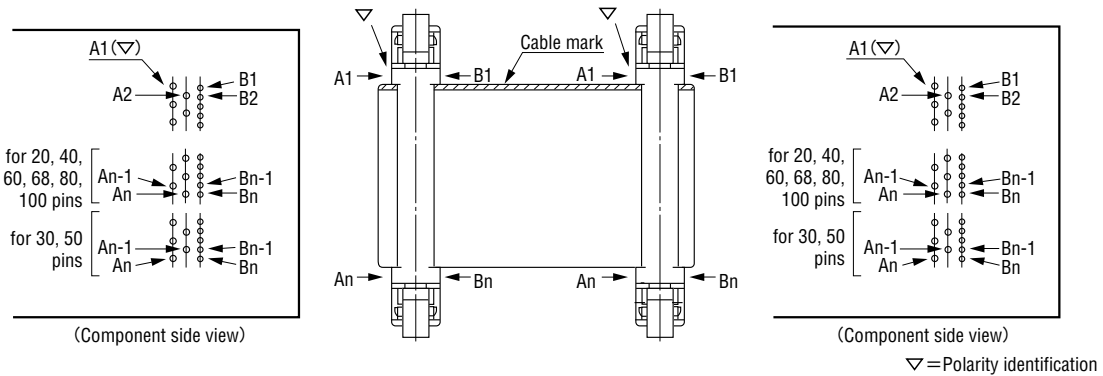

► **Daisy chain assembly (Example: GZH wiring)**

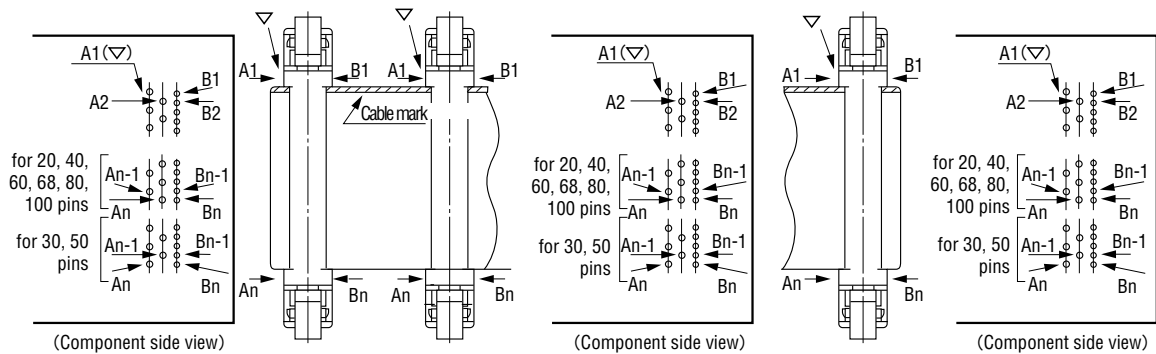

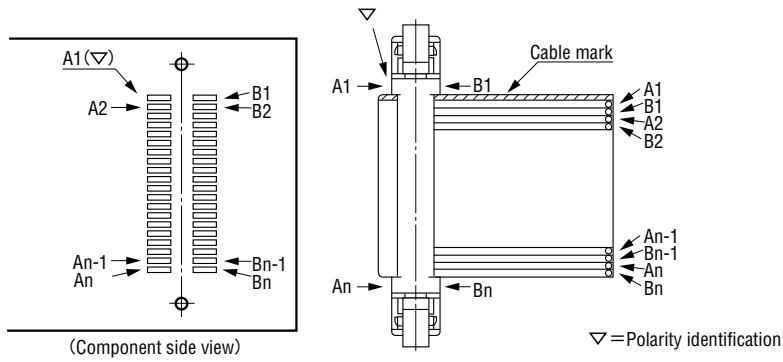
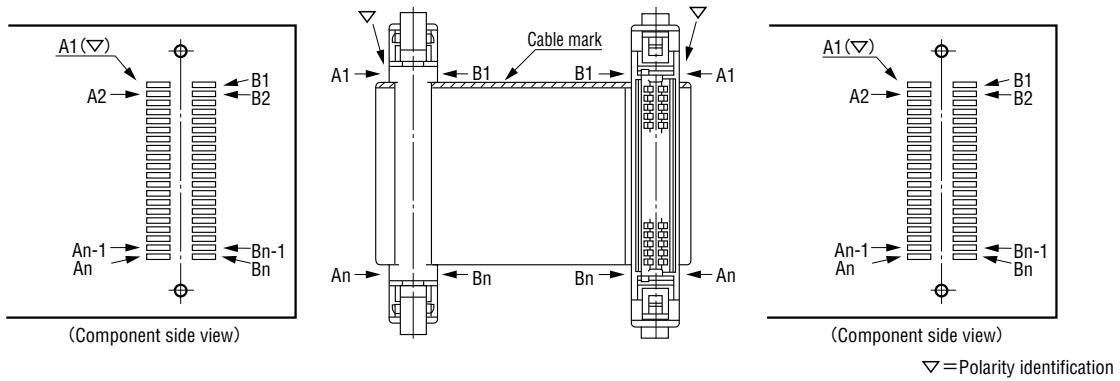
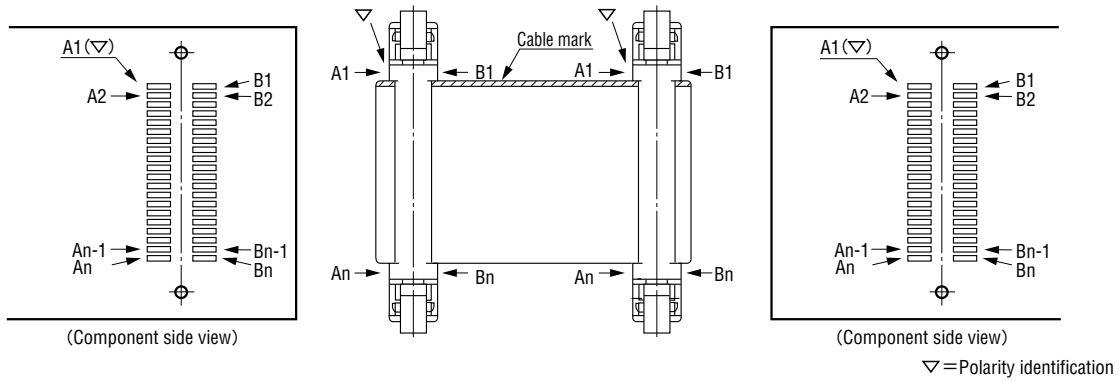
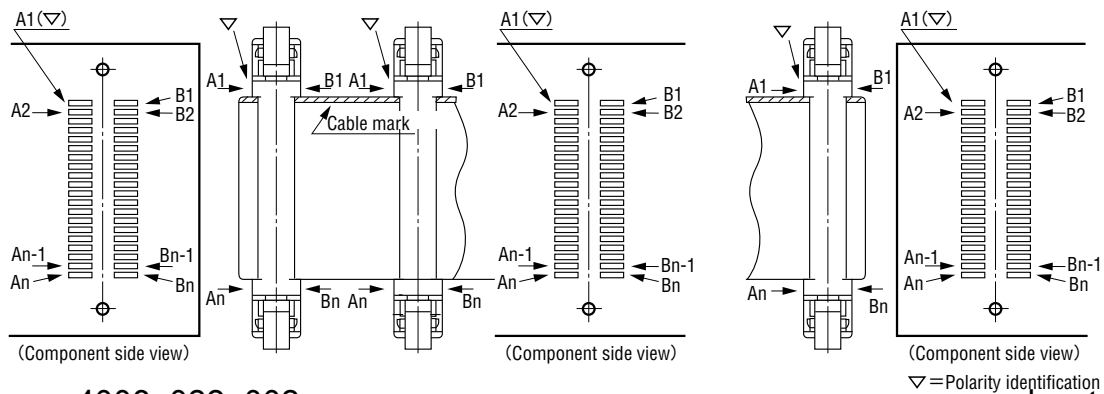
8925□/8930E SERIES PIN ASSIGNMENT (Straight, SMT)
► Single end assembly (Example: GO wiring)

► Double end assembly (Example: GG wiring)

► Double end assembly (Example: GH wiring)

► Daisy chain assembly (Example: GZH wiring)

Cable assembly tools

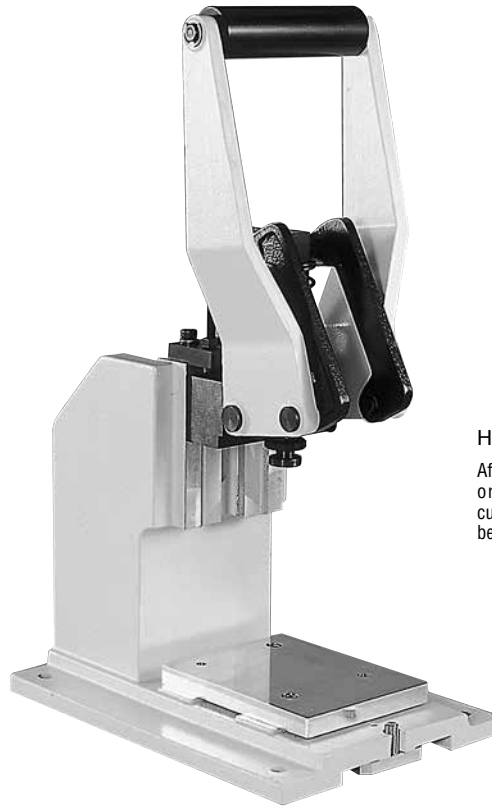
A smooth procedure from cutting of a flat cable to terminal connection to a connector can be achieved.

A hand press (HP-12), cable terminator, and termination equipment, which are designed to be user-friendly and to achieve advanced workability, can be utilized for more speedy and reliable insulation displacement connection between a flat cable and receptacle-side connector (8925□ Series).

The cable terminator and termination equipment can be easily replaced on a plate of the hand press. By attaching a relevant accessory, a series of tasks, such as those "from cutting of a cable to terminal connection to a connector" can be efficiently completed.



Hand press (HP-12)

After mounting the cable terminator or termination equipment, both cutting and terminal connection can be operated by the handle.

◆ Locating fixture for HP-12

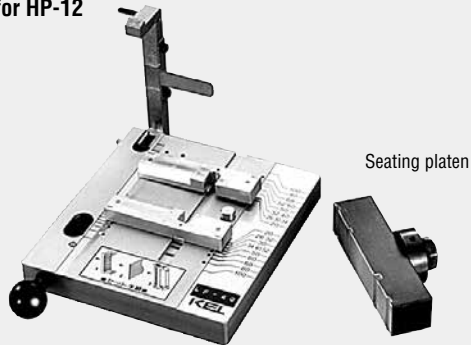

Termination equipment(LF-40)

It is to be mounted on the plate of a hand press to facilitate the insulation displacement connection between a cable and connector (for 8925□ Series).

* The termination equipment (LF-40) is supplied in combination with a seating platen.



Cable terminator(CT-15)

It is to be mounted on the plate of a hand press to cut a flat cable.

* Configuration of the termination equipment and cable terminator illustrated above may be changed due to their modifications.