



Confidential for TIA/QIN only



datasheet

PRODUCT SPECIFICATION

1/9" CMOS 720p (1280 x 720) HD image sensor
with PureCel® technology

OV9734/OV9234

Copyright © 2017 OmniVision Technologies, Inc. All rights reserved.

This document is provided “as is” with no warranties whatsoever, including any warranty of merchantability, non-infringement, fitness for any particular purpose, or any warranty otherwise arising out of any proposal, specification, or sample.

OmniVision Technologies, Inc. and all its affiliates disclaim all liability, including liability for infringement of any proprietary rights, relating to the use of information in this document. No license, expressed or implied, by estoppel or otherwise, to any intellectual property rights is granted herein.

The information contained in this document is considered proprietary to OmniVision Technologies, Inc. and all its affiliates. This information may be distributed to individuals or organizations authorized by OmniVision Technologies, Inc. to receive said information. Individuals and/or organizations are not allowed to re-distribute said information.

Trademark Information

PureCel, OmniVision, the OmniVision logo is a registered trademark of OmniVision Technologies, Inc.

All other trademarks used herein are the property of their respective owners.

CMOS 720p (1280 x 720) HD image sensor with PureCel® technology

datasheet (CSP)
PRODUCT SPECIFICATION

version 2.01
may 2017

To learn more about OmniVision Technologies, visit www.ovt.com.

applications

- smart phones
- PC multimedia
- tablets
- digital still cameras
- toys

ordering information

- **OV09734-H16A** (color, lead-free)
16-pin CSP
- **OV09234-H16A** (b&w, lead-free)
16-pin CSP

features

- support for image sizes: full size (1280x720), VGA (640x480), 2x2 RGB binning (640x360) and 2x2 BW binning (640x360)
- support for output formats: RAW output with 1-lane MIPI
- capable of maintaining register values at software power down
- programmable controls for frame rate, mirror and flip, gain/exposure, and windowing
- support for horizontal and vertical sub-sampling
- automatic black level calibration (ABLC)
- defect pixel correction (DPC)
- support for black sun cancellation
- standard SCCB interface
- on-chip phase lock loop (PLL)
- GPIO tri-state configurability and programmable polarity

key specifications (typical)

- **active array size:** 1280 x 720
- **power supply:**
analog: 2.6 ~ 3.0V (2.8V normal)
core: 1.2VDC \pm 5%
I/O: 1.8V
- **power requirements:**
active: 69 mW
XSHUTDN: 0.9 μ W
- **temperature range:**
operating: -30°C to 85°C junction temperature (see [table 7-2](#))
stable image: 0°C to 50°C junction temperature (see [table 7-2](#))
- **output formats:** 10-bit Raw RGB
- **lens size:** 1/9"
- **lens chief ray angle:** 32.1° (see [figure 9-2](#))
- **input clock frequency:** 6 ~ 27 MHz (see [table 7-5](#))
- **scan mode:** progressive
- **maximum image transfer rate:** (see [table 2-2](#))
- **sensitivity:** 585 mV/Lux-sec
- **shutter:** rolling shutter
- **max S/N ratio:** 36.4 dB
- **dynamic range:** 68.4 dB @ 16x gain
- **maximum exposure interval:** 798 x t_{ROW}
- **pixel size:** 1.4 μ m x 1.4 μ m
- **dark current:** 2e⁻⁷/sec @ 50°C junction temperature
- **image area:** 1819.58 μ m x 1033.34 μ m
- **package dimensions:** 2532 x 1722 μ m

Confidential for
TIANQIN only

table of contents

1	signal descriptions	1-1
2	system level description	2-1
2.1	overview	2-1
2.2	architecture	2-1
2.3	I/O control	2-4
2.4	format and frame rate	2-4
2.5	MIPI interface	2-4
2.6	power management	2-5
2.7	power up sequence	2-5
2.7.1	on-chip power up	2-5
2.8	power down sequence	2-7
2.9	system clock control	2-9
2.10	SCCB interface	2-10
2.11	group write	2-10
3	block level description	3-1
3.1	pixel array structure	3-1
3.2	2x2 binning	3-2
3.3	analog amplifier	3-3
3.4	10-bit A/D converters	3-3
4	image sensor core digital functions	4-1
4.1	mirror and flip	4-1
4.2	test pattern	4-2
4.2.1	color bar	4-2
4.3	exposure control/ gain control	4-3
4.4	black level calibration (BLC)	4-3
5	image sensor processor digital functions	5-1
5.1	ISP general control	5-1
6	register tables	6-1
6.1	general status [0x0100, 0x0103, 0x0106, 0x300A - 0x300B, 0x302A, 0x3820, 0x4A00]	6-1
6.2	SCCB control [0x0107, 0x3031]	6-2
6.3	IO control [0x3001 - 0x3002]	6-2
6.4	clock configuration [0x3080 - 0x3083, 0x3103]	6-3

6.5	analog control [0x3600 - 0x363F]	6-3
6.6	output format control [0x3654]	6-3
6.7	sensor control [0x3700 - 0x370C]	6-4
6.8	PSRAM control [0x3780 - 0x3785]	6-4
6.9	frame timing [0x3800 - 0x381D, 0x3820 - 0x3829]	6-4
6.10	AEC control [0x3500 - 0x3505, 0x3509 - 0x350B, 0x3510 - 0x3513]	6-7
6.11	BLC control [0x4000 - 0x4017, 0x4020 - 0x4041, 0x4050 - 0x405D]	6-8
6.12	frame control [0x4201 - 0x4202]	6-12
6.13	MIPI control [0x4800 - 0x4808, 0x4810 - 0x483D, 0x484A - 0x484F]	6-13
6.14	ISP control [0x5000 - 0x5009, 0x500B - 0x5017]	6-21
6.15	pre_ISP [0x5080]	6-23
6.16	MWB control [0x5180 - 0x5185]	6-23
6.17	WINC control [0x5700 - 0x570C]	6-24
6.18	DPC control [0x5780 - 0x5794, 0x5797 - 0x579D]	6-25
7	operating specifications	7-1
7.1	absolute maximum ratings	7-1
7.2	functional temperature	7-1
7.3	DC characteristics	7-2
7.4	AC characteristics	7-3
8	mechanical specifications	8-1
8.1	physical specifications	8-1
8.2	IR reflow specifications	8-2
9	optical specifications	9-1
9.1	sensor array center	9-1
9.2	lens chief ray angle (CRA)	9-2

list of figures

figure 1-1	pin diagram	1-2
figure 2-1	OV9734/OV9234 block diagram	2-2
figure 2-2	reference design schematic	2-3
figure 2-3	power up sequence	2-6
figure 2-4	power down sequence	2-8
figure 2-5	PLL diagram	2-9
figure 3-1	sensor array region color filter layout	3-1
figure 3-2	example of 2x2 RGB binning	3-2
figure 3-3	example of BW binning	3-2
figure 4-1	mirror and flip samples	4-1
figure 4-2	color bar types	4-2
figure 8-1	package specifications	8-1
figure 8-2	IR reflow ramp rate requirements	8-2
figure 9-1	sensor array center	9-1
figure 9-2	chief ray angle (CRA)	9-2

Confidential for
TIANQIN only

Confidential for
TIANQIN only

list of tables

table 1-1	signal descriptions	1-1
table 2-1	driving capability and direction control for I/O pins	2-4
table 2-2	format and frame rate	2-4
table 2-3	power up sequence timing constraints	2-5
table 2-4	power down sequence timing constraints	2-7
table 2-5	context switching control	2-10
table 3-1	binning-related registers	3-2
table 4-1	image orientation control registers	4-1
table 4-2	test pattern registers	4-2
table 4-3	exposure/gain control functions	4-3
table 4-4	black level calibration controls	4-3
table 5-1	ISP general control registers	5-1
table 6-1	general status registers	6-1
table 6-2	SCCB control registers	6-2
table 6-3	IO control registers	6-2
table 6-4	clock configuration registers	6-3
table 6-5	analog control registers	6-3
table 6-6	output format control register	6-3
table 6-7	sensor control registers	6-4
table 6-8	PSRAM control registers	6-4
table 6-9	frame timing registers	6-4
table 6-10	AEC control registers	6-7
table 6-11	BLC control registers	6-8
table 6-12	frame control registers	6-12
table 6-13	MIPI control registers	6-13
table 6-14	ISP control registers	6-21
table 6-15	pre_ISP register	6-23
table 6-16	MWB control registers	6-23
table 6-17	WINC control registers	6-24
table 6-18	DPC control registers	6-25
table 7-1	absolute maximum ratings	7-1
table 7-2	functional temperature	7-1

table 7-3	DC characteristics ($-30^{\circ}\text{C} < T_J < 85^{\circ}\text{C}$)	7-2
table 7-4	AC characteristics ($T_A = 25^{\circ}\text{C}$, $V_{DD-IO} = 2.8\text{V}$)	7-3
table 7-5	timing characteristics	7-3
table 8-1	package dimensions	8-1
table 8-2	reflow conditions	8-2
table 9-1	CRA versus image height plot	9-2

Confidential for
TIANQIN only

1 signal descriptions

table 1-1 lists the signal descriptions and their corresponding pin numbers for the OV9734/OV9234 image sensor. The package information is shown in **section 8**.

table 1-1 signal descriptions

pin number	signal name	pin type	description
A2	VN	reference	internal analog reference
A4	SID	input	SCCB address selection
A6	SDA	I/O	SCCB data
A8	DOGND	ground	ground for I/O circuit
B1	AGND	ground	ground for analog circuit
B3	XSHUTDN	input	reset and power down (active low with internal pull down resistor)
B5	FSIN/VSYN	I/O	FSIN/VSYN output
B7	SCL	input	SCCB input clock
C2	AVDD	power	power for analog circuit
C4	MDN0	I/O	MIPI TX data lane 0 negative output
C6	MCN	I/O	MIPI TX clock lane negative output
C8	DVDD	power	power for digital circuit
D1	XVCLK	input	system input clock
D3	MDP0	I/O	MIPI TX data lane 0 positive output
D5	MCP	I/O	MIPI TX clock lane positive output
D7	DOVDD	power	power for I/O circuit

figure 1-1 pin diagram

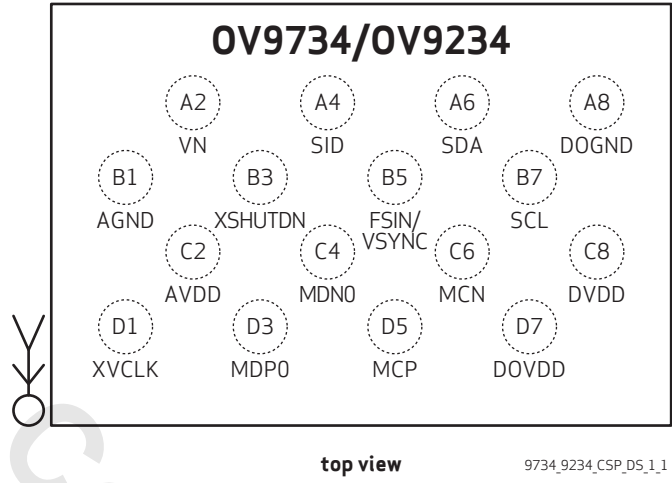

Confidential for
TIANQIN only

2 system level description

2.1 overview

The OV9734 (color) and OV9234 (b&w) image sensors are low voltage, high-performance, 1/9-inch, 720p, CMOS, image sensors that provide the full functionality of a single chip, 720p (1280x720) and VGA (640x480) camera using PureCel® technology. They provide full-frame, sub-sampled and cropped images in various formats via the control of the Serial Camera Control Bus (SCCB) interface.

The OV9734/OV9234 has an image array capable of operating at up to 30 frames per second (fps) in 720p resolution and 45 fps in VGA resolution with complete user control over image quality, formatting and output data transfer. Some image processing functions, such as exposure control, defective pixel canceling are programmable through the SCCB interface. In addition, OmniVision image sensors use proprietary sensor technology to improve image quality by reducing or eliminating common lighting/electrical sources of image contamination, such as fixed pattern noise, smearing, etc., to produce a clean, fully stable, color image.

2.2 architecture

The OV9734/OV9234 sensor core generates streaming pixel data at a constant frame rate. **figure 2-1** shows the functional block diagram of the OV9734/OV9234 image sensor. **figure 2-2** shows an example application schematic using an OV9734/OV9234 sensor.

The timing generator outputs clocks to access the rows of the imaging array, precharging and sampling the rows of the array sequentially. In the time between precharging and sampling a row, the charge in the pixels decreases with exposure to incident light. This is the exposure time in rolling shutter architecture.

The exposure time is controlled by adjusting the time interval between precharging and sampling. After the data of the pixels in the row has been sampled, it is processed through analog circuitry to correct the offset and multiply the data with corresponding gain. Following analog processing is the ADC which outputs 10-bit data for each pixel in the array.

figure 2-1 OV9734/OV9234 block diagram

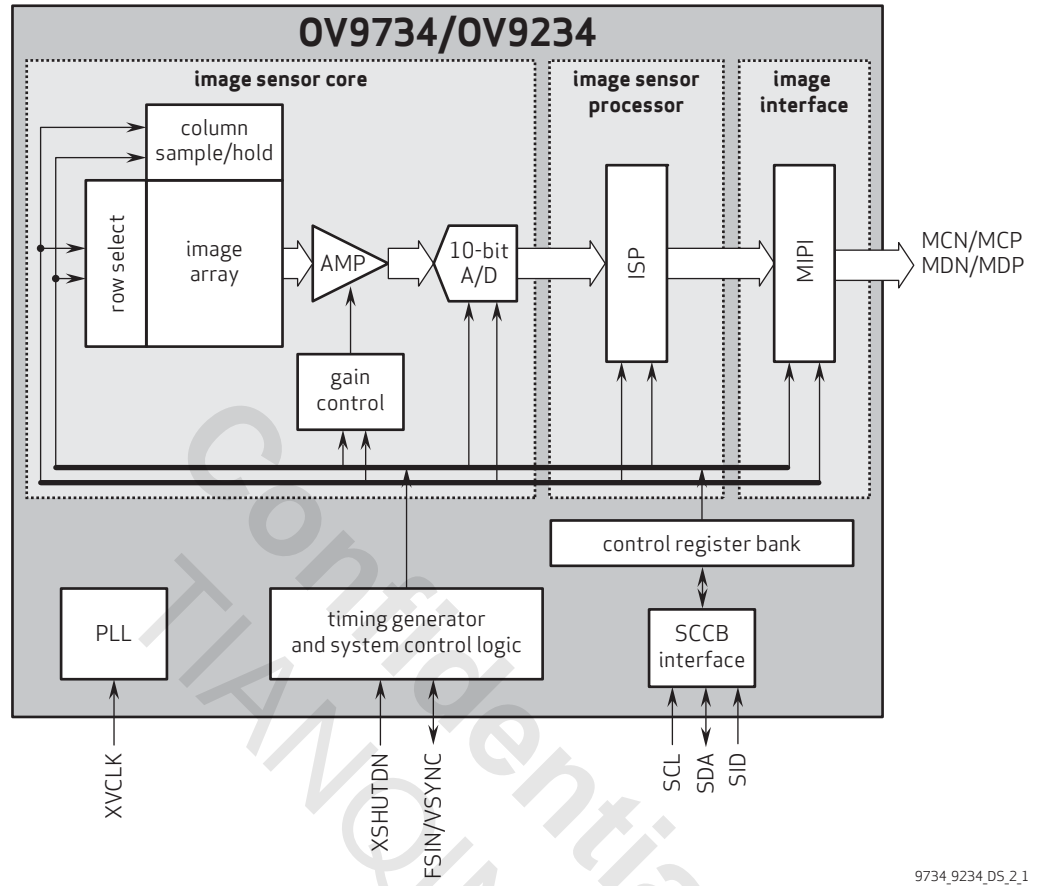

9734_9234_DS_2_1

figure 2-2 reference design schematic

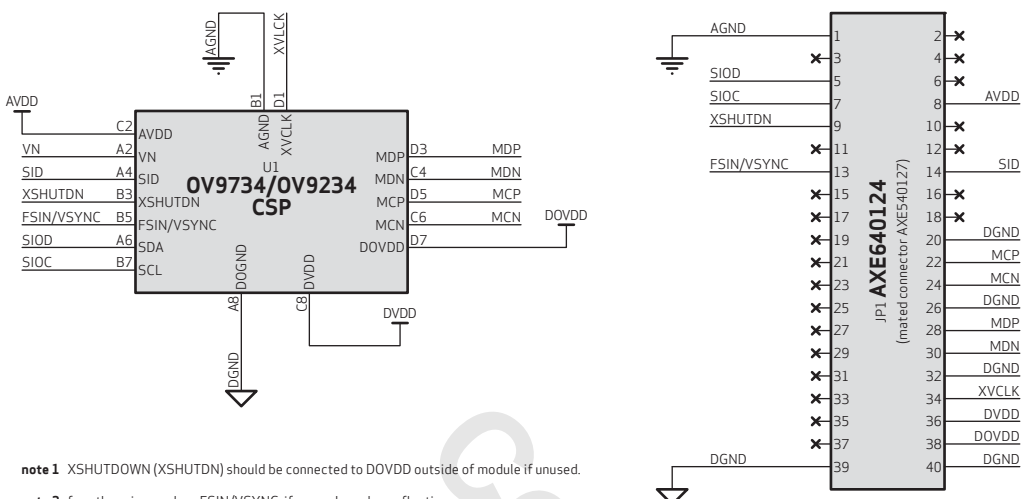

note 1 XSHUTDOWN (XSHUTDN) should be connected to DOVDD outside of module if unused.

note 2 for other pins, such as FSIN/VSYN, if unused, can leave floating.

note 3 AVDD is 2.8V of sensor analog power (clean).

note 4 DOVDD is 1.8V of sensor digital IO power (clean).

note 5 DVDD is 1.2V of sensor digital power, and need to provide externally.

note 6 sensor AGND and DGND should be separated and connected to a single point outside PCB (do not be connected inside module).

note 7 capacitors should be close to their related sensor pins.

note 8 if more space is available, use 1 μ F-0402 capacitor between DVDD and DGND.

note 9 traces of MCP, MCN, MDP, and MDN should have the same or similar length. differential impedance of the clock pair and data pair transmission lines should be controlled at 100 Ohm.

note 10 SID pin should be pulled low for device address 0x6C and pulled high for device address 0x20.

note 11 all NC pins can be left floating or connected to GND if needed.

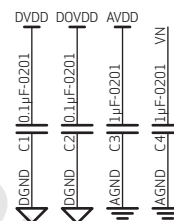

9734_9234_CSP_DS_2,2

2.3 I/O control

The OV9734/OV9234 I/O pad direction and driving capability can be easily adjusted. Driving capability and direction control for I/O pads lists the driving capability and direction control registers of the I/O pins.

table 2-1 driving capability and direction control for I/O pins

function	register	description
output drive capability control	0x3009	Bit[6:5]: output drive capability for MIPI 00: 1x 01: 2x 10: 3x 11: 4x
MIPI I/O control	0x3001	I/O control for MIPI may control any clock and data depending on the signal on certain output ports Bit[0]: MIPI output enable 0: Input 1: Output
MIPI I/O control	0x3002	I/O control for MIPI Bit[3:0]: MIPI output enable 0: Input 1: Output

2.4 format and frame rate

The OV9734/OV9234 supports the following formats: RAW8, RAW10 through MIPI.

table 2-2 format and frame rate

format	resolution	frame rate	methodology	MIPI speed
Full, 10-bit	(1280+8)x(720+8)	30 fps	full resolution	360 Mbps
VGA, 10-bit	(640+8)x(480+8)	45 fps	crop from full	360 Mbps
2x2 binning RGB	(640+4)x(360+4)	60 fps	binning	360 Mbps
2x2 binning BW	(640+4)x(360+4)	60 fps	horizontal neighbor pixels binning; vertical neighbor pixels subsampling	360 Mbps

2.5 MIPI interface

The OV9734/OV9234 supports one lane MIPI interface. The MIPI interface is capable of a data transfer rate of up to 480 Mbps.

2.6 power management

OmniVision recommends cutting off all power supplies, including the external DVDD, when the sensor is not in use.

2.7 power up sequence

The digital and analog supply voltages can be powered up in any order (e.g., DOVDD then AVDD or AVDD then DOVDD). DVDD is supplied later.

2.7.1 on-chip power up

The XVCLK clock can either be initially low and then enabled during software standby mode or XVCLK can be a free running clock.

table 2-3 power up sequence timing constraints

constraint	label	min	max	unit
AVDD rising - DOVDD rising	t0	AVDD and DOVDD may rise in any order		ns
DOVDD rising - AVDD rising	t1	rising separation can vary from 0 ns to infinity		ns
DVDD rising - XSHUTDN rising	t2	0.0	∞	
XSHUTDN rising - first SCCB transaction	t3	8192		XVCLK cycles
minimum number of XVCLK cycles prior to first SCCB transaction	t4	8192		XVCLK cycles
PLL start up/lock time	t5		0.2	ms
entering streaming mode - first frame start sequence (fixed part)	t6		10	ms
entering streaming mode - first frame start sequence (variable part)	t7	delay is integration time value		lines
AVDD or DVDD, whichever is last - DVDD rising	t8	0.0		

figure 2-3 power up sequence

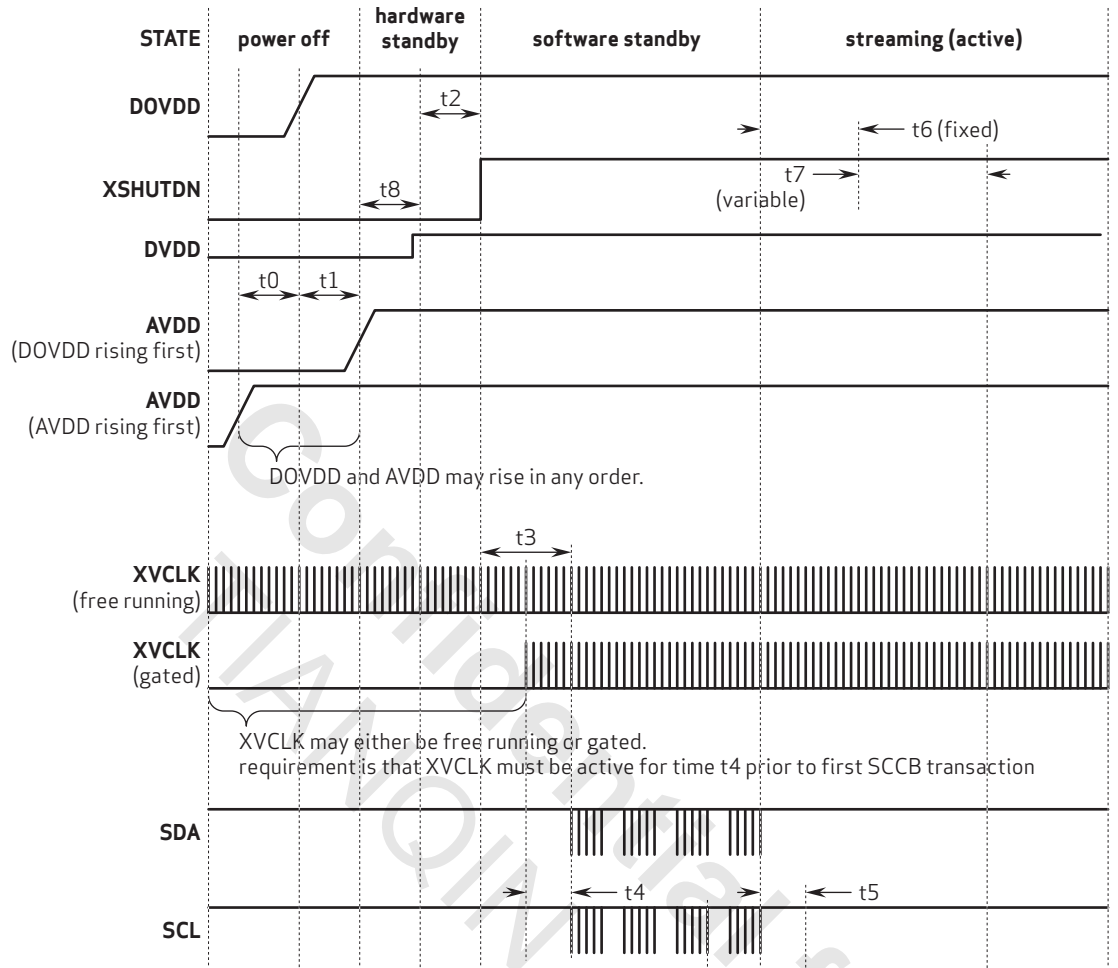

9734_9234_DS_2_3

2.8 power down sequence

The digital and analog supply voltages can be powered down in any order (e.g., DOVDD, then AVDD or AVDD, then DOVDD). Similar to the power-up sequence, the XVCLK input clock may be either gated or continuous. If the SCCB command to exit streaming is received while a frame of data is being output, then the sensor must wait for the frame end before entering software standby mode.

If the SCCB command to exit streaming mode is received during the enter frame time, then the sensor must enter software standby mode immediately.

table 2-4 power down sequence timing constraints

constraint	label	min	max	unit
enter software standby SCCB command device in software standby mode	t0	when a frame of data is output, wait for end before entering software for standby; otherwise, enter software standby mode immediately		
minimum of XVCLK cycles after last SCCB transaction or MIPI frame end	t1	512		XVCLK cycles
last SCCB transaction or MIPI frame end, XSHUTDN falling	t2	512		XVCLK cycles
DVDD fall - AVDD or DOVDD, whichever is first	t3	0		
AVDD falling - DOVDD falling	t4	AVDD and DOVDD may fall in any order, falling separation can vary from 0 ns to infinity		ns
DOVDD falling - AVDD falling	t5			ns
XSHUTDN fall - DVDD fall	t8	0		

figure 2-4 power down sequence

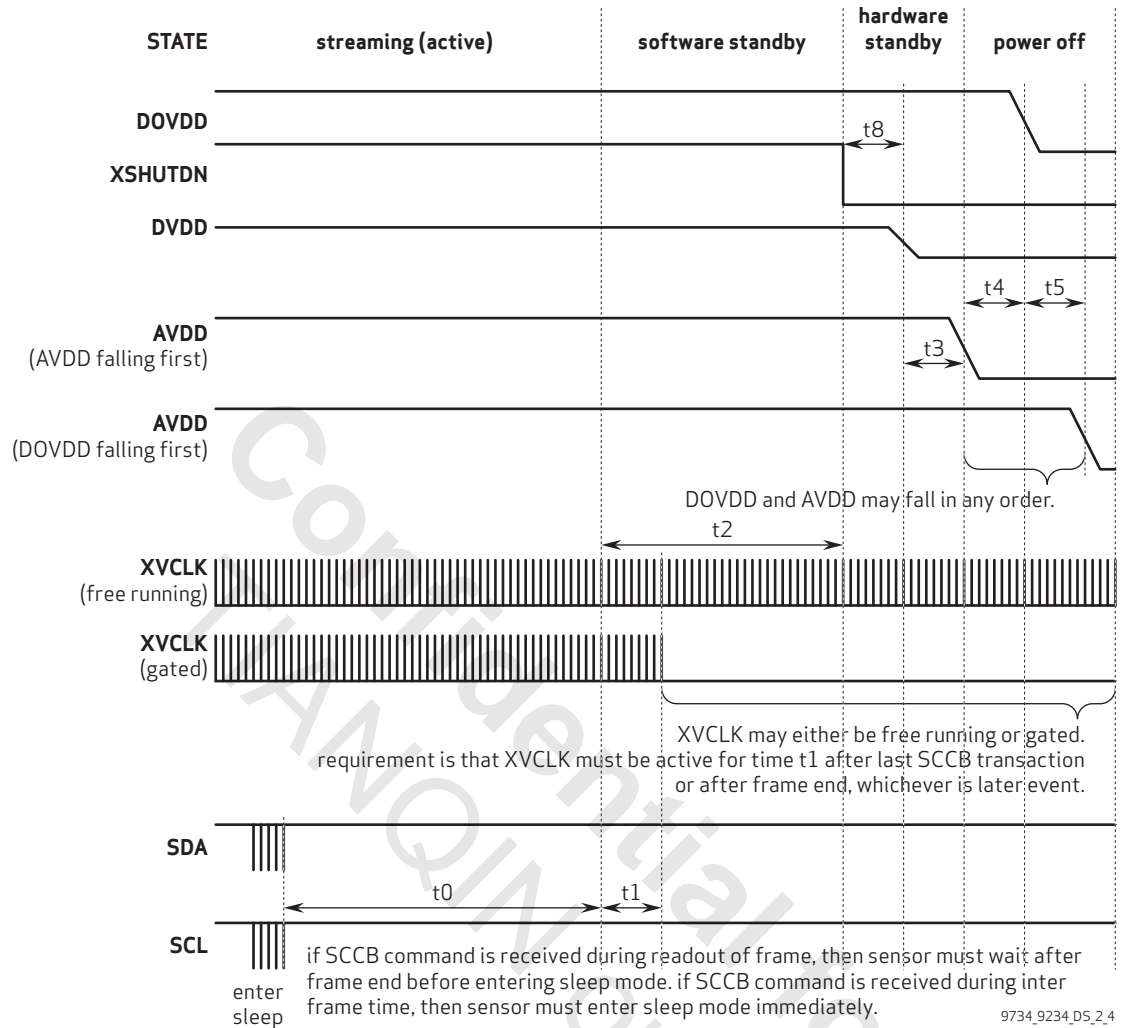

2.9 system clock control

The OV9734/OV9234 PLL allows for an input clock frequency ranging from 6~27 MHz.

PLL settings can only be changed during sensor standby mode (0x0100 = 0).

figure 2-5 PLL diagram

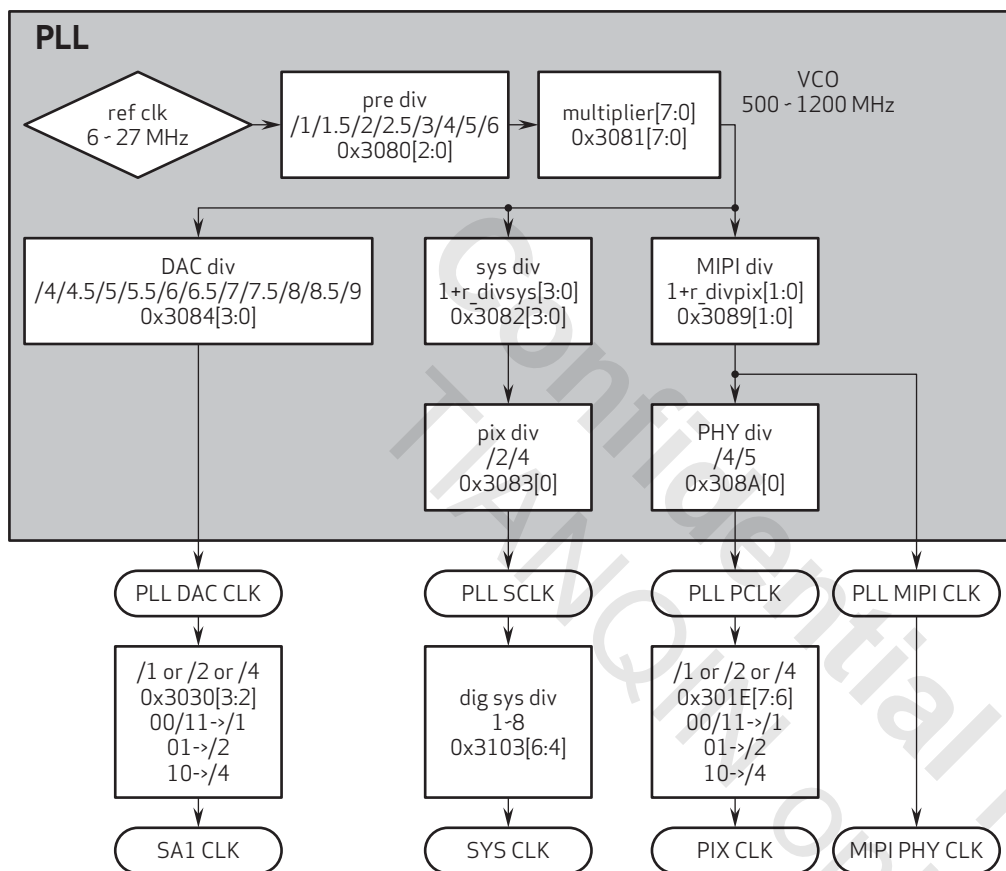

9734_9234_05_2_5

2.10 SCCB interface

The Serial Camera Control Bus (SCCB) interface controls the image sensor operation. Refer to the *OmniVision Technologies Serial Camera Control Bus (SCCB) Specification* for detailed usage of the serial control port.

2.11 group write

Group write is supported in order to update a group of registers (except 0x31xx) in the same frame. These registers are guaranteed to be written prior to the internal latch at the frame boundary.

The OV9734/OV9234 supports up to 16 bytes of registers for group write.

table 2-5 context switching control

address	register name	default value	R/W	description
0x3208	GROUP ACCESS	–	W	Group Access Bit[7:4]: group_ctrl 0000: Group hold start 0001: Group hold end Others: Debug mode Bit[3:0]: Debug mode

After the group is configured, users can perform a hold operation to store register settings into the SRAM. The hold of the group starts and ends with control register 0x3208.

After the contents of the group is defined in the hold operation, all registers belonging to the group are stored in SRAM, and ready to be written into target registers (i.e., launch of the group).

The example setting below shows the sequence to hold and launch the group:

```

6C 3208 00  group hold start
6C 3800 11  first register into group
6C 3911 22  second register into group
6C 3208 10  group hold end
6C 3208 A0  launch group

```

3 block level description

3.1 pixel array structure

The OV9734/OV9234 sensor has an image array of 1296 columns by 736 rows (953,856 pixels). **figure 3-1** shows a cross-section of the image sensor array.

The color filters are arranged in a Bayer pattern. The primary color BG/GR array is arranged in line-alternating fashion. Of the 953,856 pixels, 921,600 (1280x720) are active pixels and can be output. The other pixels are used for black level calibration and interpolation. The center 1288x728 pixels are suggested to be output from the whole active pixel array. The background processor can use the boundary pixels for additional processing.

The sensor array design is based on a field integration read-out system with line-by-line transfer and an electronic shutter with a synchronous pixel read-out scheme.

figure 3-1 sensor array region color filter layout

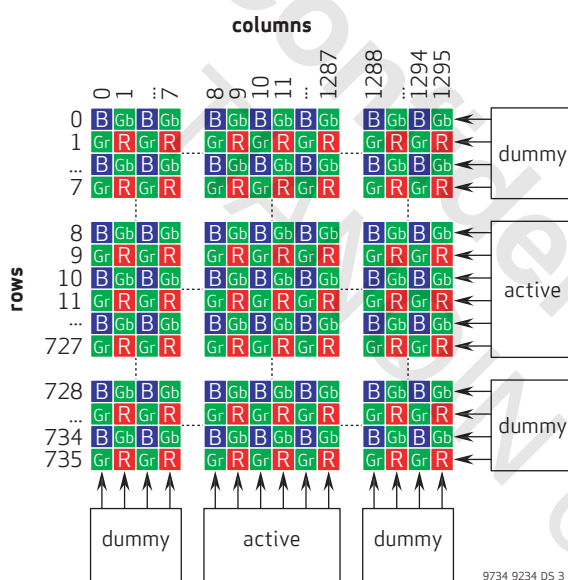

3.2 2x2 binning

The OV9734/OV9234 supports a binning mode to provide a lower resolution output while maintaining the field of view. The OV9734/OV9234 supports 2x2 RGB binning, which is illustrated in **figure 3-2**, and BW binning (horizontal binning only; vertical subsampling), which is illustrated in **figure 3-3**.

figure 3-2 example of 2x2 RGB binning

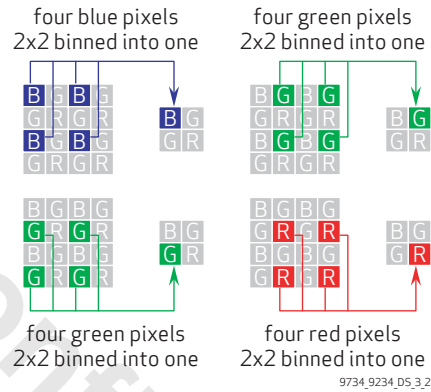

figure 3-3 example of BW binning

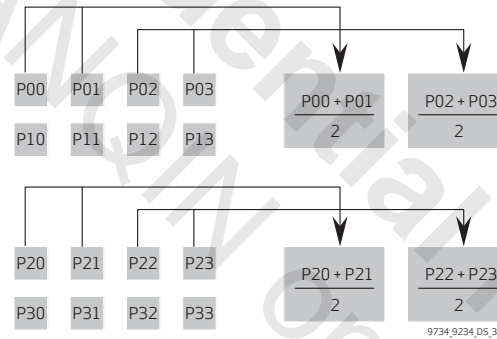

table 3-1 binning-related registers

address	register name	default value	R/W	description
0x37C0	BIN_AVG	0x07	RW	Bit[2]: Binning average/sum select 0: Binning sum 1: Binning average
0x3820	TIMING_FORMAT	0x08	RW	Bit[1]: Horizontal binning Bit[0]: Vertical binning

3.3 analog amplifier

When the column sample/hold circuit has sampled one row of pixels, the pixel data will shift out one-by-one into an analog amplifier.

3.4 10-bit A/D converters

The balanced signal is then digitized by the on-chip 10-bit ADC.

Confidential for
TIANQIN only

Confidential for
TIANQIN only

4 image sensor core digital functions

4.1 mirror and flip

The OV9734/OV9234 provides mirror mode, which reverses the sensor data read-out order horizontally and flip mode, which reverses it vertically, (see [figure 4-1](#)).

figure 4-1 mirror and flip samples

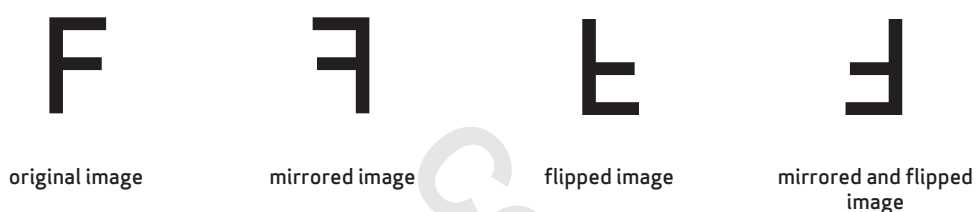

9734_9234_DS_4_1

table 4-1 image orientation control registers

address	register name	default value	R/W	description
0x3820	ORIENTATION	0x10	RW	Bit[4]: BLC_flip ON/OFF select Control together with bit[2] 0: BLC_flip OFF 1: BLC_flip ON Bit[3]: Mirror ON/OFF select 0: Mirror OFF 1: Mirror ON Bit[2]: Flip ON/OFF select 0: Flip OFF 1: Flip ON

4.2 test pattern

For testing purposes, the OV9734/OV9234 offers a color bar option.

4.2.1 color bar

There are four types of color bar which are switched by the bar-style register (0x5080[3:2]).

figure 4-2 color bar types



table 4-2 test pattern registers

address	register name	default value	R/W	description
0x5080	PRE_CTRL00	0x00	RW	Bit[7]: Test pattern enable 0: Disable test function 1: Enable test function Bit[3:2]: color_bar_style 00: Standard color bar 01: Top-bottom darker color bar 10: Right-left darker color bar 11: Bottom-top darker color bar

4.3 exposure control/ gain control

The exposure control and gain control allow the image sensor to adjust the image brightness to a desired range by setting the proper exposure time and gain applied to the image. Exposure time and gain can be set manually from an external controller. The related registers are listed in [table 4-3](#).

table 4-3 exposure/gain control functions

function	register	description
AEC enable	0x3503	Bit[0]: AEC enable 0: Reserved 1: Manual
AEC (exposure time)	{0x3501, 0x3502}	0x3501[7:0] = AEC[15:8] 0x3502[7:0] = AEC[7:0]
AGC enable	0x3503	Bit[1]: AGC enable 0: Reserved 1: Manual
AGC (gain)	{0x350A, 0x350B} ^a	0x350A = analog_gain_code_global[9:8] 0x350B = analog_gain_code_global[7:0]

a. 1x gain and maximum (15.5x) gain of analog_gain[9:0] is 0x10 and 0xF8, respectively

4.4 black level calibration (BLC)

The OV9734/OV9234 black level calibration function compensates for dark current to ensure constant output black level regardless of change in exposure time, gain and temperature.

table 4-4 black level calibration controls

function	register	description
BLC enable	0x5000	Bit[0]: BLC enable 0: Disable 1: Enable
auto/manual mode	0x4001	Bit[4]: Offset manual mode 0: Auto mode 1: Manual mode
target	{0x4002[1:0], 0x4003}	Black Level to be Achieved

Confidential for
TIANQIN only

5 image sensor processor digital functions

5.1 ISP general control

table 5-1 ISP general control registers

address	register name	default value	R/W	description
0x5000	ISP CTRL00	0x2F	RW	ISP Control 00 (0: disable; 1: enable) Bit[6]: pre_isp_man_en Bit[5]: Reserved Bit[4]: awb_gain_en Bit[3]: bc_en Bit[2]: wc_en Bit[1]: dcblc_en Bit[0]: blc_en
0x5001	ISP CTRL01	0x20	RW	Bit[6]: sof_sel Bit[5]: eof_sel1 Bit[4]: eof_sel0 Bit[3]: awb_out_sel Bit[2]: pre_out_sel Bit[1]: blc_out_sel Bit[0]: byp_isp_sel
0x5002	ISP CTRL02	0x10	RW	Bit[4]: bias_plus Bit[3]: bias_man_en Bit[2]: blkv_in Bit[1]: imgv_in Bit[0]: no_latch
0x5003	ISP CTRL03	0x10	RW	Bit[7:0]: bias_man[7:0]
0x5004	ISP CTRL4	0x01	RW	Bit[7]: size_man_en Bit[6:4]: win_y_offset_adjust
0x5006	ISP CTRL06	0x00	RW	Bit[7:0]: Manual horizontal size[15:8]
0x5007	ISP CTRL07	0x00	RW	Bit[7:0]: Manual horizontal size[7:0]
0x5008	ISP CTRL08	0x00	RW	Bit[7:0]: Manual vertical size[15:8]
0x5009	ISP CTRL09	0x00	RW	Bit[7:0]: Manual vertical size[7:0]
0x500B	DPC SRAM TEST	0x02	RW	Bit[5]: dpc_sram_test1 Bit[4]: dpc_sram_rme Bit[3:0]: dpc_sram_rm

Confidential for
TIANQIN only

6 register tables

The following tables provide descriptions of the device control registers contained in the OV9734/OV9234. For all register enable/disable bits, ENABLE = 1 and DISABLE = 0. The device slave address is 0x6C for write and 0x6D for read (when SID=1, 0x20 for write and 0x21 for read).

6.1 general status [0x0100, 0x0103, 0x0106, 0x300A - 0x300B, 0x302A, 0x3820, 0x4A00]

table 6-1 general status registers

address	byte	register name	default value	R/W	description
0x0100		MODE_SELECT	0x00	RW	Mode Select for Software Standby 0: Sleep 1: Streaming
0x0103		SOFTWARE_RESET	0x00	RW	Software Reset Setting this register to 1 resets sensor to its power up defaults. Value of this bit is also reset 0: Off 1: On
0x0106		FAST_STANDBY_CTRL	0x00	RW	Fast Standby Control 0: Frame completes before mode entry 1: Frame may be truncated before mode entry
0x300A	Hi	CHIP ID	0x97	R	Sensor Chip ID High Byte
0x300B	Lo	CHIP ID	0x34	R	Sensor Chip ID Low Byte
0x302A		CHIP REVISION	0xA0	R	Bit[7:0]: Chip revision number
0x3820		IMAGE_ORIENTATION	0x10	RW	Image Orientation Bit[7:5]: Debug mode Bit[4]: BLC_flip Bit[3]: Horizontal mirror 0: Disable 1: Enable Bit[2]: Vertical flip 0: Disable 1: Enable Bit[1:0]: Debug mode
0x4A00		FRAME_COUNT	–	R	Bit[7:0]: Frame counter value (0-255)



note Use the registers below to get minimum standby current, which controls more registers than only the 0x0100:

```
@@ Sleep_On
6c 0100 00
6c 3658 FF
6c 3659 FF
6c 365a FF
6c 308b 01
@@ Sleep_Off
6c 3658 00
6c 3659 00
6c 365a 00
6c 308b 00
6c 0100 01
```

6.2 SCCB control [0x0107, 0x3031]

table 6-2 SCCB control registers

address	register name	default value	R/W	description
0x0107	CCI_ADDRESS_PGM_ID	0x78	RW	Expressed as 8-bit SCCB Programmable ID
0x3031	SCCB	0x02	RW	Expressed as 8-bit Bit[7:2]: Not used Bit[1]: SCCB programmable ID enable Bit[0]: sccb_id2_nack_en

6.3 IO control [0x3001 - 0x3002]

table 6-3 IO control registers

address	register name	default value	R/W	description
0x3001	PCLK/HREF/VSYNC OEN	0x00	RW	Bit[7:1]: Debug mode Bit[0]: Input/output control for GPIO port VYSNC
0x3002	GPIO OEN	0x00	RW	Bit[7:4]: Debug mode Bit[3]: GPIO port 3 Bit[2]: GPIO port 2 Bit[1]: GPIO port 1 Bit[0]: GPIO port 0

6.4 clock configuration [0x3080 - 0x3083, 0x3103]

table 6-4 clock configuration registers

address	register name	default value	R/W	description
0x3080	PRE_PLL_CLK_DIV	0x02	RW	Bit[7:3]: Debug mode Bit[2:0]: Pre PLL clock divider value[2:0]
0x3081	PLL_MULTIPLIER	0x3C	RW	Bit[7:0]: PLL multiplier value[7:0]
0x3082	VT_SYS_CLK_DIV	0x04	RW	Bit[7:4]: Debug mode Bit[3:0]: Video timing system clock divider[3:0]
0x3083	VT_PIXEL_CLK_DIV	0x00	RW	Bit[7:1]: Debug mode Bit[0]: Video timing pixel clock divider[0]
0x3103	SYS_CLK_DIV	0x01	RW	Bit[7]: Debug mode Bit[6:4]: Output system clock divider 0x0~0x7: Div by 1 ~ 8 Bit[3:0]: Debug mode

6.5 analog control [0x3600 - 0x363F]

table 6-5 analog control registers

address	register name	default value	R/W	description
0x3600~ 0x363F	RSVD	-	-	Reserved

6.6 output format control [0x3654]

table 6-6 output format control register

address	register name	default value	R/W	description
0x3654	FMT CTRL	0x10	RW	Output Format Control Bit[7:6]: Debug mode Bit[5]: RAW8/RAW10 output select 0: RAW10 1: RAW8 Bit[4:0]: Debug mode

6.7 sensor control [0x3700 - 0x370C]

table 6-7 sensor control registers

address	register name	default value	R/W	description
0x3700~ 0x370C	RSVD	–	–	Reserved

6.8 PSRAM control [0x3780 - 0x3785]

table 6-8 PSRAM control registers

address	register name	default value	R/W	description
0x3780~ 0x3785	RSVD	–	–	Reserved

6.9 frame timing [0x3800 - 0x381D, 0x3820 - 0x3829]

table 6-9 frame timing registers (sheet 1 of 4)

address	register name	default value	R/W	description
0x3800	X ADDR START	0x00	RW	Bit[7:0]: x_addr_start[15:8] Array horizontal start point high byte
0x3801	X ADDR START	0x04	RW	Bit[7:0]: x_addr_start[7:0] Array horizontal start point low byte
0x3802	Y ADDR START	0x00	RW	Bit[7:0]: y_addr_start[15:8] Array vertical start point high byte
0x3803	Y ADDR START	0x04	RW	Bit[7:0]: y_addr_start[7:0] Array vertical start point low byte
0x3804	X ADDR END	0x05	RW	Bit[7:0]: x_addr_end[15:8] Array horizontal end point high byte
0x3805	X ADDR END	0x0B	RW	Bit[7:0]: x_addr_end[7:0] Array horizontal end point low byte
0x3806	Y ADDR END	0x02	RW	Bit[7:0]: y_addr_end[15:8] Array vertical end point high byte

table 6-9 frame timing registers (sheet 2 of 4)

address	register name	default value	R/W	description
0x3807	Y ADDR END	0xDB	RW	Bit[7:0]: y_addr_end[7:0] Array vertical end point low byte
0x3808	X OUTPUT SIZE	0x05	RW	Bit[7:0]: x_output_size[15:8] ISP horizontal output width high byte
0x3809	X OUTPUT SIZE	0x00	RW	Bit[7:0]: x_output_size[7:0] ISP horizontal output width low byte
0x380A	Y OUTPUT SIZE	0x02	RW	Bit[7:0]: y_output_size[15:8] ISP vertical output height high byte
0x380B	Y OUTPUT SIZE	0xD0	RW	Bit[7:0]: y_output_size[7:0] ISP vertical output height low byte
0x380C	HTS	0x05	RW	Bit[7:0]: HTS[15:8] Total pixels per line high byte
0x380D	HTS	0xC6	RW	Bit[7:0]: HTS[7:0] Total pixels per line low byte
0x380E	VTS	0x03	RW	Bit[7:0]: VTS[15:8] Total lines per frame high byte
0x380F	VTS	0x22	RW	Bit[7:0]: VTS[7:0] Total lines per frame low byte
0x3810	ISP X WIN	0x00	RW	Bit[7:0]: isp_x_win[15:8] ISP horizontal windowing offset high byte
0x3811	ISP X WIN	0x04	RW	Bit[7:0]: isp_x_win[7:0] ISP horizontal windowing offset low byte
0x3812	ISP Y WIN	0x00	RW	Bit[7:0]: isp_y_win[15:8] ISP vertical windowing offset high byte
0x3813	ISP Y WIN	0x04	RW	Bit[7:0]: isp_y_win[7:0] ISP vertical windowing offset low byte
0x3814	VSYNC CS POINT	0x00	RW	Bit[7:0]: vsync_cs_point[15:8]
0x3815	VSYNC CS POINT	0x01	RW	Bit[7:0]: vsync_cs_point[7:0]
0x3816	VSYNC START ROW	0x00	RW	Bit[7:0]: vsync_start_row[15:8]
0x3817	VSYNC START ROW	0x00	RW	Bit[7:0]: vsync_start_row[7:0]
0x3818	VSYNC END ROW	0x00	RW	Bit[7:0]: vsync_end_row[15:8]
0x3819	VSYNC END ROW	0x04	RW	Bit[7:0]: vsync_end_row[7:0]

table 6-9 frame timing registers (sheet 3 of 4)

address	register name	default value	R/W	description
0x381A	HSYNC FIRST	0x00	RW	Bit[7:0]: hsync_first[15:8] HSYNC first active row start position high byte
0x381B	HSYNC FIRST	0x00	RW	Bit[7:0]: hsync_first[7:0] HSYNC first active row start position low byte
0x381C	REG1C	0x01	RW	Bit[7:6]: Not used Bit[5]: init_man Bit[4]: vsync_polarity Bit[3]: ext_vs_re Bit[2]: ext_vs_en Bit[1:0]: grp_wr_start
0x381D	REG1C	0x20	RW	Bit[7:4]: Not used Bit[3:0]: fsin_mask Mask frame sync pulse 0: Input mode: sync sensor every one of {bit[3:0]+1} FSIN pulses 1: Output mode: output one VSYNC at each {bit[3:0]+1} frames
0x3820	FORMAT0	0x10	RW	Bit[7:5]: Not used Bit[4]: BLC_Flip Bit[3]: Mirror Bit[2]: vflip Bit[1]: hbin Bit[0]: vbin
0x3821	FORMAT1	0x00	RW	Bit[7:4]: Not used Bit[3:2]: hsub 00: Full 01: hsub2 10: hsub4 Bit[1:0]: vsub 00: Full 01: vsub2 10: vsub4
0x3822	CS RST FSIN	0x00	RW	Bit[7:0]: cs_rst_fsin[15:8] CS reset value high byte at vs_ext
0x3823	CS RST FSIN	0x00	RW	Bit[7:0]: cs_rst_fsin[7:0] CS reset value low byte at vs_ext
0x3824	R RST FSIN	0x00	RW	Bit[7:0]: r_rst_fsin[15:8] R reset value high byte at vs_ext
0x3825	R RST FSIN	0x00	RW	Bit[7:0]: r_rst_fsin[7:0] R reset value low byte at vs_ext

table 6-9 frame timing registers (sheet 4 of 4)

address	register name	default value	R/W	description
0x3826	FVTS	0x00	RW	Bit[7:0]: FVTS[15:8] Fractional vertical timing size high byte
0x3827	FVTS	0x00	RW	Bit[7:0]: FVTS[7:0] Fractional vertical timing size low byte
0x3828	LN SYNC POINT	0x00	RW	Bit[7:0]: ln_sync_point[15:8] Unit is 16×sclk
0x3829	LN SYNC POINT	0x10	RW	Bit[7:0]: ln_sync_point[7:0] Unit is 16×sclk

6.10 AEC control [0x3500 - 0x3505, 0x3509 - 0x350B, 0x3510 - 0x3513]

table 6-10 AEC control registers (sheet 1 of 2)

address	register name	default value	R/W	description
0x3500	LONG EXPO	0x00	RW	Bit[7:4]: Debug mode Bit[3:0]: Long exposure[19:16]
0x3501	LONG EXPO	0x20	RW	Bit[7:0]: Long exposure[15:8]
0x3502	LONG EXPO	0x00	RW	Bit[7:0]: Long exposure[7:0] Low 4 bits are fraction bits
0x3503	AEC MANUAL	0x03	RW	Bit[7:6]: Not used Bit[5]: Gain change delay option 0: Not delay 1 frame 1: Delay 1 frame Bit[4]: Delay option 0: Disable 1: Enable Bit[3]: gain_change_delay Bit[2]: vts_manual Bit[1]: agc_manual Bit[0]: aec_manual
0x3504	MANUAL SNR GAIN	0x00	RW	Bit[7:2]: Not used Bit[1:0]: Manual sensor gain[9:8]
0x3505	MANUAL SNR GAIN	0x00	RW	Bit[7:0]: Manual sensor gain[7:0]
0x3509	AEC CTRL 9	0x10	RW	Bit[7:5]: Not used Bit[4]: convert_en Bit[3]: gain_man_en Bit[2:0]: Not used



note For optimal performance, minimum exposure should be 4 lines. For more details, contact your local OmniVision FAE.

table 6-10 AEC control registers (sheet 2 of 2)

address	register name	default value	R/W	description
0x350A	LONG GAIN	0x00	RW	Bit[7:2]: Not used Bit[1:0]: Long gain[9:8]
0x350B	LONG GAIN	0x10	RW	Bit[7:0]: Long gain[7:0]
0x3510	PK GAIN	–	R	Bit[7:2]: Not used Bit[1:0]: pk_gain_o[9:8]
0x3511	PK GAIN	–	R	Bit[7:0]: pk_gain_o[7:0]
0x3512	SNR GAIN	–	R	Bit[7:2]: Not used Bit[1:0]: snr_gain[9:8]
0x3513	SNR GAIN	–	R	Bit[7:0]: snr_gain[7:0]

6.11 BLC control [0x4000 - 0x4017, 0x4020 - 0x4041, 0x4050 - 0x405D]

table 6-11 BLC control registers (sheet 1 of 5)

address	register name	default value	R/W	description
0x4000	BLC CTRL 00	0xC1	RW	Bit[7:4]: Avg_weight Bit[3]: Target adjust disable Use offset to adjust target 0: Enable 1: Disable Bit[2]: Compensation enable Adjust on offset due to gain change 0: Enable 1: Disable Bit[1]: Dither_en 1 bit dithering 0: Enable 1: Disable Bit[0]: Median_en Median filter function enable
0x4001	BLC CTRL 01	0xE0	RW	Bit[7]: gain_trig_beh Bit[5]: format_trig_beh Bit[5]: Kocef manual enable Bit[4]: Offset manual enable Bit[3]: Zero line out enable Bit[2]: Black line out enable Bit[1:0]: Bypass mode
0x4002	BLC CTRL 02	0x00	RW	Bit[7:2]: Debug mode Bit[1:0]: Blacklevel target[9:8]

table 6-11 BLC control registers (sheet 2 of 5)

address	register name	default value	R/W	description
0x4003	BLC CTRL 03	0x10	RW	Bit[7:0]: Blacklevel target[7:0]
0x4004	BLC CTRL 04	0x00	RW	Bit[7:3]: Debug mode Bit[2:0]: Horizontal win start[10:8]
0x4005	BLC CTRL 05	0x02	RW	Bit[7:0]: Horizontal win start[7:0]
0x4006	BLC CTRL 06	0x00	RW	Bit[7:3]: Debug mode Bit[2:0]: Horizontal win pad[10:8]
0x4007	BLC CTRL 07	0x02	RW	Bit[7:0]: Horizontal win pad[7:0]
0x4008	BLC CTRL 08	0x00	RW	Bit[7:0]: Black line start line
0x4009	BLC CTRL 09	0x0B	RW	Bit[7:0]: Black line end line
0x400A	BLC CTRL 0A	0x02	RW	Bit[7:0]: Offset trigger threshold[15:8]
0x400B	BLC CTRL 0B	0x00	RW	Bit[7:0]: Offset trigger threshold[7:0]
0x400C	BLC CTRL 0C	0x00	RW	Bit[7:0]: CVDN black lines start
0x400D	BLC CTRL 0D	0x00	RW	Bit[7:0]: CVDN black lines end
0x400E	BLC CTRL 0E	0x00	RW	Bit[7:2]: Debug mode Bit[1:0]: Kcoef man value[9:8]
0x400F	BLC CTRL 0F	0x80	RW	Bit[7:0]: Kcoef man value[7:0]
0x4010	BLC CTRL 10	0xF0	RW	Bit[7]: Offset trigger enable Bit[6]: Gain change trigger enable Bit[5]: Format change trigger enable Bit[4]: Reset trigger enable Bit[3]: Manual average enable Bit[2]: Manual trigger Bit[1]: Freeze enable Bit[0]: Offset always update
0x4011	BLC CTRL 11	0xFF	RW	Bit[7]: Debug mode Bit[6]: Offset trigger multiframe enable Bit[5]: Format trigger multiframe enable Bit[4]: Gain trigger multiframe enable Bit[3]: Reset trigger multiframe enable Bit[2]: Offset trigger multiframe mode Bit[1]: Format trigger multiframe mode Bit[0]: Gain trigger multiframe mode
0x4012	BLC CTRL 12	0x08	RW	Bit[7:6]: Debug mode Bit[5:0]: Reset trigger frame number
0x4013	BLC CTRL 13	0x02	RW	Bit[7:6]: Debug mode Bit[5:0]: Format trigger frame number
0x4014	BLC CTRL 14	0x02	RW	Bit[7:6]: Debug mode Bit[5:0]: Gain trigger frame number

table 6-11 BLC control registers (sheet 3 of 5)

address	register name	default value	R/W	description
0x4015	BLC CTRL 15	0x02	RW	Bit[7:6]: Debug mode Bit[5:0]: Offset trigger frame number
0x4016	BLC CTRL 16	0x00	RW	Bit[7:2]: Debug mode Bit[1:0]: Offset trigger threshold[9:8]
0x4017	BLC CTRL 17	0x10	RW	Bit[7:0]: Offset trigger threshold[7:0]
0x4020	BLC CTRL 20	0x00	RW	Bit[7:6]: Debug mode Bit[5:0]: Offset compensation th000
0x4021	BLC CTRL 21	0x00	RW	Bit[7:6]: Debug mode Bit[5:0]: Offset compensation k000
0x4022	BLC CTRL 22	0x00	RW	Bit[7:6]: Debug mode Bit[5:0]: Offset compensation th001
0x4023	BLC CTRL 23	0x00	RW	Bit[7:6]: Debug mode Bit[5:0]: Offset compensation k001
0x4024	BLC CTRL 24	0x00	RW	Bit[7:6]: Debug mode Bit[5:0]: Offset compensation th010
0x4025	BLC CTRL 25	0x00	RW	Bit[7:6]: Debug mode Bit[5:0]: Offset compensation k010
0x4026	BLC CTRL 26	0x00	RW	Bit[7:6]: Debug mode Bit[5:0]: Offset compensation th011
0x4027	BLC CTRL 27	0x00	RW	Bit[7:6]: Debug mode Bit[5:0]: Offset compensation k011
0x4028	BLC CTRL 28	0x00	RW	Bit[7:6]: Debug mode Bit[5:0]: Offset compensation th100
0x4029	BLC CTRL 29	0x00	RW	Bit[7:6]: Debug mode Bit[5:0]: Offset compensation k100
0x402A	BLC CTRL 2A	0x00	RW	Bit[7:6]: Debug mode Bit[5:0]: Offset compensation th101
0x402B	BLC CTRL 2B	0x00	RW	Bit[7:6]: Debug mode Bit[5:0]: Offset compensation k101
0x402C	BLC CTRL 2C	0x00	RW	Bit[7:6]: Debug mode Bit[5:0]: Offset compensation th110
0x402D	BLC CTRL 2D	0x00	RW	Bit[7:6]: Debug mode Bit[5:0]: Offset compensation k110
0x402E	BLC CTRL 2E	0x00	RW	Bit[7:6]: Debug mode Bit[5:0]: Offset compensation th111
0x402F	BLC CTRL 2F	0x00	RW	Bit[7:6]: Debug mode Bit[5:0]: Offset compensation k111

table 6-11 BLC control registers (sheet 4 of 5)

address	register name	default value	R/W	description
0x4030	BLC CTRL 30	0x00	RW	Bit[7:2]: Debug mode Bit[1:0]: Offset man 000[9:8]
0x4031	BLC CTRL 31	0x00	RW	Bit[7:0]: Offset man 000[7:0]
0x4032	BLC CTRL 32	0x00	RW	Bit[7:2]: Debug mode Bit[1:0]: Offset man 001[9:8]
0x4033	BLC CTRL 33	0x00	RW	Bit[7:0]: Offset man 001[7:0]
0x4034	BLC CTRL 34	0x00	RW	Bit[7:2]: Debug mode Bit[1:0]: Offset man 010[9:8]
0x4035	BLC CTRL 35	0x00	RW	Bit[7:0]: Offset man 010[7:0]
0x4036	BLC CTRL 36	0x00	RW	Bit[7:2]: Debug mode Bit[1:0]: Offset man 011[9:8]
0x4037	BLC CTRL 37	0x00	RW	Bit[7:0]: Offset man 011[7:0]
0x4038	BLC CTRL 38	0x00	RW	Bit[7:2]: Debug mode Bit[1:0]: Offset man 100[9:8]
0x4039	BLC CTRL 39	0x00	RW	Bit[7:0]: Offset man 100[7:0]
0x403A	BLC CTRL 3A	0x00	RW	Bit[7:2]: Debug mode Bit[1:0]: Offset man 101[9:8]
0x403B	BLC CTRL 3B	0x00	RW	Bit[7:0]: Offset man 101[7:0]
0x403C	BLC CTRL 3C	0x00	RW	Bit[7:2]: Debug mode Bit[1:0]: Offset man 110[9:8]
0x403D	BLC CTRL 3D	0x00	RW	Bit[7:0]: Offset man 110[7:0]
0x403E	BLC CTRL 3E	0x00	RW	Bit[7:2]: Debug mode Bit[1:0]: Offset man 111[9:8]
0x403F	BLC CTRL 3F	0x00	RW	Bit[7:0]: Offset man 111[7:0]
0x4040	BLC CTRL 40	0x00	RW	Bit[7:2]: Debug mode Bit[1:0]: r_rnd_gain_th[9:8]
0x4041	BLC CTRL 41	0x00	RW	Bit[7:0]: r_rnd_gain_th[7:0]
0x4050	BLC CTRL 50	–	R	Bit[7:2]: Debug mode Bit[1:0]: blc_offset000[9:8]
0x4051	BLC CTRL 51	–	R	Bit[7:0]: blc_offset000[7:0]
0x4052	BLC CTRL 52	–	R	Bit[7:2]: Debug mode Bit[1:0]: blc_offset001[9:8]
0x4053	BLC CTRL 53	–	R	Bit[7:0]: blc_offset001[7:0]
0x4054	BLC CTRL 54	–	R	Bit[7:2]: Debug mode Bit[1:0]: blc_offset010[9:8]

table 6-11 BLC control registers (sheet 5 of 5)

address	register name	default value	R/W	description
0x4055	BLC CTRL 55	–	R	Bit[7:0]: blc_offset010[7:0]
0x4056	BLC CTRL 56	–	R	Bit[7:2]: Debug mode Bit[1:0]: blc_offset011[9:8]
0x4057	BLC CTRL 57	–	R	Bit[7:0]: blc_offset011[7:0]
0x4058	BLC CTRL 58	–	R	Bit[7:2]: Debug mode Bit[1:0]: blc_offset100[9:8]
0x4059	BLC CTRL 59	–	R	Bit[7:0]: blc_offset100[7:0]
0x405A	BLC CTRL 5A	–	R	Bit[7:2]: Debug mode Bit[1:0]: blc_offset101[9:8]
0x405B	BLC CTRL 5B	–	R	Bit[7:0]: blc_offset101[7:0]
0x405C	BLC CTRL 5C	–	R	Bit[7:2]: Debug mode Bit[1:0]: blc_offset110[9:8]
0x405D	BLC CTRL 5D	–	R	Bit[7:0]: blc_offset110[7:0]

6.12 frame control [0x4201 - 0x4202]

table 6-12 frame control registers

address	register name	default value	R/W	description
0x4201	FC CTRL1	0x00	RW	Bit[7:4]: Not used Bit[3:0]: Number of frame on
0x4202	FC CTRL2	0x00	RW	Bit[7:4]: Not used Bit[3:0]: Number of frame off

6.13 MIPI control [0x4800 - 0x4808, 0x4810 - 0x483D, 0x484A - 0x484F]

table 6-13 MIPI control registers (sheet 1 of 9)

address	register name	default value	R/W	description
0x4800	MIPI_CTRL00	0x04	RW	Bit[7:6]: Debug mode Bit[5]: gate_sc_en 0: Clock lane is free running 1: Gate clock lane when no packet to tx Bit[4]: line_sync_en 0: Not send line short packet for each line 1: Send line short packet for each line Bit[2]: pclk_inv_o 0: Using falling edge of mipi_pclk_o to generate MIPI bus to PHY 1: Using rising edge of mipi_pclk_o to generate MIPI bus to PHY Bit[1]: first_bit Change clk_lane first bit 0: Output 8'h55 1: Output 8'hAA Bit[0]: LPX_select for pclk domain 0: Auto calculate t_lpx_p, unit pclk2x cycle 1: Use lpx_p_min[7:0]
0x4801	RSVD	–	–	Reserved

table 6-13 MIPI control registers (sheet 2 of 9)

address	register name	default value	R/W	description
0x4802	MIPI_CTRL02	0x00	RW	Bit[7]: hs_prepare_sel 0: Auto calculate T_hs_prepare, unit pclk2x 1: Use hs_prepare_min_o[7:0] Bit[6]: clk_prepare_sel 0: Auto calculate T_clk_prepare, unit pclk2x 1: Use clk_prepare_min_o[7:0] Bit[5]: clk_post_sel 0: Auto calculate T_clk_post, unit pclk2x 1: Use clk_post_min_o[7:0] Bit[4]: clk_trail_sel 0: Auto calculate T_clk_trail, unit pclk2x 1: Use clk_trail_min_o[7:0] Bit[3]: hs_exit_sel 0: Auto calculate T_hs_exit, unit pclk2x 1: Use hs_exit_min_o[7:0] Bit[2]: hs_zero_sel 0: Auto calculate T_hs_zero, unit pclk2x 1: Use hs_zero_min_o[7:0] Bit[1]: hs_trail_sel 0: Auto calculate T_hs_trail, unit pclk2x 1: Use hs_trail_min_o[7:0] Bit[0]: clk_zero_sel 0: Auto calculate T_clk_zero, unit pclk2x 1: Use clk_zero_min_o[7:0]
0x4803	MIPI_CTRL03	0x10	RW	Bit[7:5]: Debug mode Bit[4]: fifo_rd_spd_o Bit[3]: manu_offset_o t_perio manual offset SMIA Bit[2]: r_manu_half2one t_period half to 1 SMIA Bit[1:0]: Debug mode
0x4804	RSVD	–	–	Reserved
0x4805	MIPI_CTRL05	0x00	RW	Bit[7:4]: Debug mode Bit[3]: lpda_retim_manu_o Bit[2]: lpda_retim_sel_o 1: Manual Bit[1]: lpck_retim_manu_o Bit[0]: lpck_retim_sel_o 1: Manual

table 6-13 MIPI control registers (sheet 3 of 9)

address	register name	default value	R/W	description
0x4806	MIPI_CTRL06	0x00	RW	Bit[7:5]: Debug mode Bit[4]: pu_mark_en_o Power up mark1 enable Bit[3]: mipi_remot_rst Bit[2]: mipi_susp Bit[1]: smia_lane_ch_en Bit[0]: tx_lsb_first 0: High bit first 1: Low power transmit low bit first
0x4807	MIPI_CTRL07	0x03	RW	Bit[7:4]: Debug mode Bit[3:0]: sw_t_lpx ul_tx T_lpx
0x4808	MIPI_CTRL08	0x18	RW	Bit[7:0]: wkup_dly Mark1 wakeup delay/2^10
0x4810	FCNT_MAX	0xFF	RW	Bit[7:0]: fcnt_max[15:8] High byte of maximum frame counter of frame sync short packet
0x4811	FCNT_MAX	0xFF	RW	Bit[7:0]: fcnt_max[7:0] Low byte of maximum frame counter of frame sync short packet
0x4812	RSVD	–	–	Reserved
0x4813	MIPI_CTRL13	0x00	RW	Bit[7:3]: Debug mode Bit[2]: vc_sel Input VC or register VC Bit[1:0]: VC virtual channel of MIPI
0x4814	MIPI_CTRL14	0x2A	RW	Bit[7]: Debug mode Bit[6]: lpkt_dt_sel 0: Use mipi_dt 1: Use dt_man_o as long packet data Bit[5:0]: dt_man Manual data type
0x4815	RSVD	–	–	Reserved
0x4816	EMB_DT_CTRL	–	R	Bit[7]: Debug mode Bit[6]: emb_line_sel 1: Use emb_dt as data in first emb_line_nu Bit[5:0]: emb_dt Manually set embedded data type
0x4817	RSVD	–	–	Reserved

table 6-13 MIPI control registers (sheet 4 of 9)

address	register name	default value	R/W	description
0x4818	HS_ZERO_MIN	0x00	RW	Bit[7:2]: Debug mode Bit[1:0]: hs_zero_min[9:8] High byte of minimum value of hs_zero, unit ns
0x4819	HS_ZERO_MIN	0x70	RW	Bit[7:0]: hs_zero_min[7:0] Low byte of minimum value of hs_zero, unit ns $Hs_zero_real = hs_zero_min_o + Tui*ui_hs_zero_min_o$
0x481A	HS_TRAIL_MIN	0x00	RW	Bit[7:2]: Debug mode Bit[1:0]: hs_trail_min[9:8] High byte of minimum value of hs_trail, unit ns
0x481B	HS_TRAIL_MIN	0x3C	RW	Bit[7:0]: Low byte of minimum value of hs_trail, unit ns $Hs_trail_real = hs_trail_min_o + Tui*ui_hs_trail_min_o$
0x481C	CLK_ZERO_MIN	0x01	RW	Bit[7:2]: Debug mode Bit[1:0]: clk_zero_min[9:8] High byte of minimum value of clk_zero, unit ns
0x481D	CLK_ZERO_MIN	0x2C	RW	Bit[7:0]: clk_zero_min[7:0] Low byte of minimum value of clk_zero, unit ns $Clk_zero_real = clk_zero_min_o + Tui*ui_clk_zero_min_o$
0x481E	CLK_PREPARE_MAX	0x5F	RW	Bit[7:0]: clk_prepare_max[7:0] Maximum value of clk_prepare, unit ns
0x481F	CLK_PREPARE_MIN	0x26	RW	Bit[7:0]: clk_prepare_min[7:0] Minimum value of clk_prepare, unit ns $Clk_prepare_real = clk_prepare_min_o + Tui*ui_clk_prepare_min_o$
0x4820	CLK_POST_MIN	0x00	RW	Bit[7:2]: Debug mode Bit[1:0]: clk_post_min[9:8] High byte of minimum value of clk_post, unit ns
0x4821	CLK_POST_MIN	0x3C	RW	Bit[7:0]: clk_post_min[7:0] Low byte of minimum value of clk_post, unit ns $Clk_post_real = clk_post_min_o + Tui*ui_clk_post_min_o$

table 6-13 MIPI control registers (sheet 5 of 9)

address	register name	default value	R/W	description
0x4822	CLK_TRAIL_MIN	0x00	RW	Bit[7:2]: Debug mode Bit[1:0]: clk_trail_min[9:8] High byte of minimum value of clk_trail, unit ns
0x4823	CLK_TRAIL_MIN	0x3C	RW	Bit[7:0]: clk_trail_min[7:0] Low byte of minimum value of clk_trail, unit ns $\text{clk_trail_real} = \text{clk_trail_min_o} + \text{Tui} * \text{ui_clk_trail_min_o}$
0x4824	LPX_P_MIN	0x00	RW	Bit[7:2]: Debug mode Bit[1:0]: lpx_p_min[9:8] High byte of minimum value of lpx_p, unit ns
0x4825	LPX_P_MIN	0x32	RW	Bit[7:0]: lpx_p_min[7:0] Low byte of minimum value of lpx_p, unit ns $\text{lpx_p_real} = \text{lpx_p_min_o} + \text{Tui} * \text{ui_lpx_p_min_o}$
0x4826	HS_PREPARE_MIN	0x32	RW	Bit[7:0]: hs_prepare_min[7:0] Minimum value of hs_prepare, unit ns
0x4827	HS_PREPARE_MAX	0x55	RW	Bit[7:0]: hs_prepare_max[7:0] Maximum value of hs_prepare, unit ns $\text{Hs_prepare_real} = \text{hs_prepare_max_o} + \text{Tui} * \text{ui_hs_prepare_max_o}$
0x4828	HS_EXIT_MIN	0x00	RW	Bit[7:2]: Debug mode Bit[1:0]: hs_exit_min[9:8] High byte of minimum value of hs_exit, unit ns
0x4829	HS_EXIT_MIN	0x64	RW	Bit[7:0]: hs_exit_min[7:0] Low byte of minimum value of hs_exit, unit ns $\text{Hs_exit_real} = \text{hs_exit_min_o} + \text{Tui} * \text{ui_hs_exit_min_o}$
0x482A	UI_HS_ZERO_MIN	0x06	RW	Bit[7:6]: Debug mode Bit[5:0]: Minimum UI value of hs_zero, unit UI
0x482B	UI_HS_TRAIL_MIN	0x04	RW	Bit[7:6]: Debug mode Bit[5:0]: Minimum UI value of hs_trail, unit UI
0x482C	UI_CLK_ZERO_MIN	0x00	RW	Bit[7:6]: Debug mode Bit[5:0]: Minimum UI value of clk_zero, unit UI

table 6-13 MIPI control registers (sheet 6 of 9)

address	register name	default value	R/W	description
0x482D	UI_CLK_PREPARE	0x00	RW	Bit[7:4]: ui_clk_prepare_max Maximum UI value of clk_prepare, unit UI Bit[3:0]: ui_clk_prepare_min Minimum UI value of clk_prepare, unit UI
0x482E	UI_CLK_POST_MIN	0x34	RW	Bit[7:6]: Debug mode Bit[5:0]: ui_clk_post_min[5:0] Minimum UI value of clk_post, unit UI
0x482F	UI_CLK_TRAIL_MIN	0x00	RW	Bit[7:6]: Debug mode Bit[5:0]: ui_clk_trail_min[5:0] Minimum UI value of clk_trail, unit UI
0x4830	UI_LPX_P_MIN	0x00	RW	Bit[7:6]: Debug mode Bit[5:0]: ui_lpx_p_min[5:0] Minimum UI value of lpx_p (pclk2x domain), unit UI
0x4831	UI_HS_PREPARE	0x64	RW	Bit[7:4]: ui_hs_prepare_max Maximum UI value of hs_prepare, unit UI Bit[3:0]: ui_hs_prepare_min Minimum UI value of hs_prepare, unit UI
0x4832	UI_HS_EXIT_MIN	0x00	RW	Bit[7:6]: Debug mode Bit[5:0]: ui_hs_exit_min[5:0] Minimum UI value of hs_exit, unit UI
0x4833	MIPI_PKT_STAR_SIZE	0x08	RW	Bit[7:6]: Debug mode Bit[5:0]: mipi_pkt_star_size[5:0]
0x4834~ 0x4836	RSVD	–	–	Reserved
0x4837	PCLK_PERIOD	0x2D	RW	Bit[7:0]: pclk_period[7:0] Period of pclk2x, pclk_div=1, and 1 bit decimal

table 6-13 MIPI control registers (sheet 7 of 9)

address	register name	default value	R/W	description
0x4838	MIPI_LP_GPIO0	0x00	RW	Bit[7]: lp_sel0 0: Auto generate mipi_lp_dir0_o 1: Use lp_dir_man0 to be mipi_lp_dir0_o Bit[6]: lp_dir_man0 0: Input 1: Output Bit[5]: lp_p0_o Bit[4]: lp_n0_o Bit[3]: lp_sel1 0: Auto generate mipi_lp_dir1_o 1: Use lp_dir_man1 to be mipi_lp_dir1_o Bit[2]: lp_dir_man1 0: Input 1: Output Bit[1]: lp_p1_o Bit[0]: lp_n1_o
0x4839	MIPI_LP_GPIO1	0x00	RW	Bit[7]: lp_sel2 0: Auto generate mipi_lp_dir2_o 1: Use lp_dir_man2 to be mipi_lp_dir2_o Bit[6]: lp_dir_man2 0: Input 1: Output Bit[5]: lp_p2_o Bit[4]: lp_n2_o Bit[3]: lp_sel3 0: Auto generate mipi_lp_dir3_o 1: Use lp_dir_man3 to be mipi_lp_dir3_o Bit[2]: lp_dir_man3 0: Input 1: Output Bit[1]: lp_p3_o Bit[0]: lp_n3_o
0x483A~ 0x483B	RSVD	–	–	Reserved
0x483C	MIPI_CTRL3C	0x02	RW	Bit[7:4]: Debug mode Bit[3:0]: t_clk_pre Unit: pclk2x cycle

table 6-13 MIPI control registers (sheet 8 of 9)

address	register name	default value	R/W	description
0x483D	MIPI_LP_GPIO4	0x00	RW	Bit[7]: lp_ck_sel0 0: Auto generate mipi_ck_lp_dir0_o 1: Use lp_ck_dir_man0 to be mipi_ck_lp_dir0_o Bit[6]: lp_ck_dir_man0 0: Input 1: Output Bit[5]: lp_ck_p0_o Bit[4]: lp_ck_n0_o Bit[3]: lp_ck_sel1 0: Auto generate mipi_ck_lp_dir1_o 1: Use lp_ck_dir_man1 to be mipi_ck_lp_dir1_o Bit[2]: lp_ck_dir_man1 0: Input 1: Output Bit[1]: lp_ck_p1_o Bit[0]: lp_ck_n1_o
0x484A	SEL_MIPI_CTRL4A	0x3F	RW	Bit[7:6]: Debug mode Bit[5]: slp_lp_pon_man_o Set for power up Bit[4]: slp_lp_pon_da Bit[3]: slp_lp_pon_ck Bit[2]: mipi_slp_man_st MIPI bus status manual control enable in sleep mode Bit[1]: clk_lane_state Bit[0]: data_lane_state
0x484B	SMIA_OPTION	0x07	RW	Bit[7:2]: Debug mode Bit[1]: clk_start_sel_o 0: Clock starts after SOF 1: Clock starts after reset Bit[0]: sof_sel_o 0: Frame starts after HREF occurs 1: Frame starts after SOF
0x484C	SEL_MIPI_CTRL4C	0x00	RW	Bit[7:4]: Debug mode Bit[3]: smia_fcnt_i select Bit[2]: prbs_enable Bit[1]: hs_test_only MIPI high speed only test mode enable Bit[0]: set_frame_cnt_0 Set frame count to inactive mode (keep 0)
0x484D	TEST_PATTEN_DATA	0xB6	RW	Bit[7:0]: test_patten_data[7:0] Data lane test pattern register
0x484E	FE_DLY	0x10	RW	Bit[7:0]: r_fe_dly_o Last packet to frame end delay / 2

table 6-13 MIPI control registers (sheet 9 of 9)

address	register name	default value	R/W	description
0x484F	TEST_PATTEN_CHK_DATA	0x55	RW	Bit[7:0]: clk_test_patten_reg

6.14 ISP control [0x5000 - 0x5009, 0x500B - 0x5017]

table 6-14 ISP control registers (sheet 1 of 2)

address	register name	default value	R/W	description
0x5000	ISP CTRL00	0x2F	RW	ISP Control 00 (0: disable; 1: enable) Bit[7]: Debug mode Bit[6]: pre_isp_man_en Bit[5]: Debug mode Bit[4]: awb_gain_en Bit[3]: bc_en Bit[2]: wc_en Bit[1]: dcblc_en Bit[0]: blc_en
0x5001	ISP CTRL01	0x20	RW	Bit[7]: Debug mode Bit[6]: sof_sel Bit[5]: eof_sel1 Bit[4]: eof_sel0 Bit[3]: awb_out_sel Bit[2]: pre_out_sel Bit[1]: blc_out_sel Bit[0]: byp_isp_sel
0x5002	ISP CTRL02	0x10	RW	Bit[7:5]: Not used Bit[4]: bias_plus Bit[3]: bias_man_en Bit[2]: blkv_in Bit[1]: imgv_in Bit[0]: no_latch
0x5003	ISP CTRL03	0x10	RW	Bit[7:0]: bias_man[7:0]
0x5004	ISP CTRL4	0x01	RW	Bit[7]: size_man_en Bit[6:4]: win_y_offset_adjust Bit[3:0]: Not used
0x5006	ISP CTRL06	0x00	RW	Bit[7:0]: Manual horizontal size[15:8]
0x5007	ISP CTRL07	0x00	RW	Bit[7:0]: Manual horizontal size[7:0]
0x5008	ISP CTRL08	0x00	RW	Bit[7:0]: Manual vertical size[15:8]
0x5009	ISP CTRL09	0x00	RW	Bit[7:0]: Manual vertical size[7:0]

table 6-14 ISP control registers (sheet 2 of 2)

address	register name	default value	R/W	description
0x500B	DPC SRAM TEST	0x02	RW	Bit[7:6]: Not used Bit[5]: dpc_sram_test1 Bit[4]: dpc_sram_rme Bit[3:0]: dpc_sram_rm
0x500C	MANUAL X_START	0x00	RW	Bit[7:4]: Not used Bit[3:0]: pre_isp manual x_start_address[11:8]
0x500D	MANUAL X_START	0x00	RW	Bit[7:0]: pre_isp manual x_start_address[7:0]
0x500E	MANUAL X_END	0x00	RW	Bit[7:4]: Not used Bit[3:0]: pre_isp manual x_end_address[11:8]
0x500F	MANUAL X_END	0x00	RW	Bit[7:0]: pre_isp manual x_end_address[7:0]
0x5010	MANUAL Y_START	0x00	RW	Bit[7:4]: Not used Bit[3:0]: pre_isp manual y_start_address[11:8]
0x5011	MANUAL Y_START	0x00	RW	Bit[7:0]: pre_isp manual y_start_address[7:0]
0x5012	MANUAL Y_END	0x00	RW	Bit[7:4]: Not used Bit[3:0]: pre_isp manual y_end_address[11:8]
0x5013	MANUAL Y_END	0x00	RW	Bit[7:0]: pre_isp manual y_end_address[7:0]
0x5014	MANUAL X_OUTPUT_SIZE	0x00	RW	Bit[7:4]: Not used Bit[3:0]: pre_isp manual x_output_size[11:8]
0x5015	MANUAL X_OUTPUT_SIZE	0x00	RW	Bit[7:0]: pre_isp manual x_output_size[7:0]
0x5016	MANUAL Y_OUTPUT_SIZE	0x00	RW	Bit[7:4]: Not used Bit[3:0]: pre_isp manual y_output_size[11:8]
0x5017	MANUAL Y_OUTPUT_SIZE	0x00	RW	Bit[7:0]: pre_isp manual y_output_size[7:0]

6.15 pre_ISP [0x5080]

table 6-15 pre_ISP register

address	register name	default value	R/W	description
0x5080	PRE_ISP CTRL0	0x00	R/W	Bit[7]: Test pattern enable 0: Disable test function 1: Enable test function Bit[6:4]: Reserved Bit[3:2]: color_bar_style 00: Standard color bar 01: Top-bottom darker color bar 10: Right-left darker color bar 11: Bottom-top darker color bar Bit[1:0]: Reserved

6.16 MWB control [0x5180 - 0x5185]

table 6-16 MWB control registers

address	register name	default value	R/W	description
0x5180	MWB R GAIN	0x04	RW	Bit[7:4]: Not used Bit[3:0]: mwb_r_gain[11:8] ^a
0x5181	MWB R GAIN	0x00	RW	Bit[7:0]: mwb_r_gain[7:0]
0x5182	MWB G GAIN	0x04	RW	Bit[7:4]: Not used Bit[3:0]: mwb_g_gain[11:8] ^a
0x5183	MWB G GAIN	0x00	RW	Bit[7:0]: mwb_g_gain[7:0]
0x5184	MWB B GAIN	0x04	RW	Bit[7:4]: Not used Bit[3:0]: mwb_b_gain[11:8] ^a
0x5185	MWB B GAIN	0x00	RW	Bit[7:0]: mwb_b_gain[7:0]

a. 1x gain and maximum (~4x) gain of mwb_x_gain[11:0] is 0x100 and 0x3FF, respectively

6.17 WINC control [0x5700 - 0x570C]

table 6-17 WINC control registers

address	register name	default value	R/W	description
0x5700	WINC CTRL00	0x00	RW	Bit[7:5]: Not used Bit[4:0]: x_start_offset[12:8] Start address in horizontal
0x5701	WINC CTRL01	0x00	RW	Bit[7:0]: x_start_offset[7:0]
0x5702	WINC CTRL02	0x00	RW	Bit[7:5]: Not used Bit[4:0]: y_start_offset[12:8] Start address in vertical
0x5703	WINC CTRL03	0x00	RW	Bit[7:0]: y_start_offset[7:0]
0x5704	WINC CTRL04	0x02	RW	Bit[7:5]: Not used Bit[4:0]: window_width[12:8] Select whole zone width high byte
0x5705	WINC CTRL05	0x80	RW	Bit[7:0]: window_width[7:0] Select whole zone width low byte
0x5706	WINC CTRL06	0x01	RW	Bit[7:4]: Not used Bit[3:0]: window_height[11:8] Select whole zone height high byte
0x5707	WINC CTRL07	0xE0	RW	Bit[7:0]: window_height[7:0] Select whole zone height low byte
0x5708	WINC CTRL08	0x00	RW	Bit[7:3]: Reserved Bit[2]: flip_offset_en Bit[1]: Window enable option Bit[0]: Manual window enable
0x5709	WINC RO09	–	R	Bit[7:4]: Not used Bit[3:0]: Pixel count[11:8] for debug
0x570A	WINC RO0A	–	R	Bit[7:0]: Pixel count[7:0] for debug
0x570B	WINC RO0B	–	R	Bit[7:4]: Not used Bit[3:0]: Line count[11:8] for debug
0x570C	WINC RO0C	–	R	Bit[7:0]: Line count[7:0] for debug

6.18 DPC control [0x5780 - 0x5794, 0x5797 - 0x579D]

table 6-18 DPC control registers (sheet 1 of 2)

address	register name	default value	R/W	description
0x5780	DPC CTRL00	0x14	RW	Bit[7:6]: Not used Bit[5]: enable_tail Bit[4]: enable_saturate_crosscluster Bit[3]: enable_3x3_cluster Bit[2]: enable_crosscluster Bit[1]: enable_general_tail Bit[0]: manual_mode_en
0x5781	DPC CTRL01	0x0F	RW	Bit[7:4]: Saturate Bit[3]: enable_diffchannel_wpconn Bit[2]: enable_diffchannel_bpconn Bit[1]: enable_samechannel_wpconn Bit[0]: enable_samechannel_bpconn
0x5782	DPC CTRL02	0x44	RW	Bit[7:4]: status_thre_step Bit[3:0]: wthre_list0
0x5783	WTHRE LIST1	0x02	RW	Bit[7:4]: Not used Bit[3:0]: wthre_list1[7:0]
0x5784	WTHRE LIST2	0x01	RW	Bit[7:4]: Not used Bit[3:0]: wthre_list2[7:0]
0x5785	WTHRE LIST3	0x01	RW	Bit[7:4]: Not used Bit[3:0]: wthre_list3[7:0]
0x5786	ADPT PTN THRE	0x00	RW	Bit[7:4]: Not used Bit[3:0]: adptive_pattern_thre[3:0]
0x5787	ADPT PTN STEP	0x04	RW	Bit[7:4]: Not used Bit[3:0]: adptive_pattern_step[3:0]
0x5788	CON THRE	0x08	RW	Bit[7:4]: Not used Bit[3:0]: more_connection_case_thre[3:0]
0x5789	DPC LVL LIST0	0x0F	RW	Bit[7:0]: dpc_level_list0[7:0]
0x578A	DPC LVL LIST1	0xFD	RW	Bit[7:0]: dpc_level_list1[7:0]
0x578B	DPC LVL LIST2	0xF5	RW	Bit[7:0]: dpc_level_list2[7:0]
0x578C	DPC LVL LIST3	0xF5	RW	Bit[7:0]: dpc_level_list3[7:0]
0x578D	GAIN LIST0	0x03	RW	Bit[7:4]: Not used Bit[6:0]: gain_list0[7:0]
0x578E	GAIN LIST1	0x0F	RW	Bit[7:4]: Not used Bit[6:0]: gain_list1[7:0]

table 6-18 DPC control registers (sheet 2 of 2)

address	register name	default value	R/W	description
0x578F	GAIN LIST2	0x3F	RW	Bit[7]: Not used Bit[6:0]: gain_list2[7:0]
0x5790	MATCH THRE	0x08	RW	Bit[7:4]: Not used Bit[3:0]: matching_threshold[3:0]
0x5791	STATUS THRE	0x04	RW	Bit[7:4]: Not used Bit[3:0]: status_threshold[3:0]
0x5792	THRE RATIO	0x04	RW	Bit[7:4]: Not used Bit[3:0]: threshold_ratio[3:0]
0x5793	DPC CTRL13	0x52	RW	Bit[7:6]: vnum_list1 Bit[5:4]: vnum_list0 Bit[3:2]: Not used Bit[1]: v153_en Bit[0]: clip_intg_en
0x5794	DPC CTRL14	0xA3	RW	Bit[7:6]: vnum_list3 Bit[5:4]: vnum_list2 Bit[3:2]: Not used Bit[1:0]: edge_option
0x5797	BTHRE	–	R	Bit[7]: Not used Bit[6:0]: black_threshold[6:0]
0x5798	WTHRE	–	R	Bit[7:5]: Not used Bit[4:0]: white_threshold[4:0]
0x5799	THRE1	–	R	Bit[7:5]: Not used Bit[4:0]: Threshold1[4:0]
0x579A	THRE2	–	R	Bit[7:5]: Not used Bit[4:0]: Threshold2[4:0]
0x579B	THRE3	–	R	Bit[7:5]: Not used Bit[4:0]: Threshold3[4:0]
0x579C	THRE4	–	R	Bit[7:5]: Not used Bit[4:0]: Threshold4[4:0]
0x579D	LEVEL	–	R	Bit[7:4]: Not used Bit[3:0]: Level

7 operating specifications

7.1 absolute maximum ratings

table 7-1 absolute maximum ratings

parameter		absolute maximum rating ^a
ambient storage temperature		-40°C to +125°C
supply voltage (with respect to ground)	V_{DD-IO}	4.5V
electro-static discharge (ESD)	human body model	2000V
	machine model	200V
all input/output voltages (with respect to ground)		-0.3V to $V_{DD-IO} + 1V$
I/O current on any input or output pin		± 200 mA
peak solder temperature (10 second dwell time)		245°C

- a. exceeding the absolute maximum ratings shown above invalidates all AC and DC electrical specifications and may result in permanent damage to the device. Exposure to absolute maximum rated conditions for extended periods may affect device reliability.

7.2 functional temperature

table 7-2 functional temperature

parameter	range
operating temperature ^a	-30°C to +85°C junction temperature
stable image temperature ^b	0°C to 50°C junction temperature

- a. sensor functions but image quality may be noticeably different at temperatures outside of stable image range
 b. image quality remains stable throughout this temperature range

7.3 DC characteristics

table 7-3 DC characteristics ($-30^{\circ}\text{C} < T_J < 85^{\circ}\text{C}$)

symbol	parameter	min	typ	max	unit
supply					
V_{DD-A}	supply voltage (analog)	2.6	2.8	3.0	V
V_{DD-D}	supply voltage (digital core)	1.14	1.2	1.26	V
V_{DD-IO}	supply voltage (digital I/O)	1.7	1.8	1.9	V
I_{DD-A}	active (operating) current		18.5	35	mA
I_{DD-D}			12	16	mA
I_{DD-IO}			1.5	2.2	mA
$I_{DDS-SCCB}^a$	standby current		60	1500	μA
$I_{DDS-XSHUTDN}$			0.5	10	μA
digital inputs (typical conditions: DOVDD = 1.8V)					
V_{IL}	input voltage LOW			0.54	V
V_{IH}	input voltage HIGH	1.26			V
C_{IN}	input capacitor			10	pF
digital outputs (standard loading 25 pF)					
V_{OH}	output voltage HIGH	1.62			V
V_{OL}	output voltage LOW			0.18	V
serial interface inputs					
V_{IL}	SCL and SDA	-0.5	0	0.54	V
V_{IH}	SCL and SDA	1.26	1.8	2.3	V

- a. standby current is measured at room temperature with external clock off. Use the registers below to get minimum standby current, which controls more registers than only the 0x0100:

```

@@ Sleep_On
6c 0100 00
6c 3658 FF
6c 3659 FF
6c 365a FF
6c 308b 01
@@ Sleep_Off
6c 3658 00
6c 3659 00
6c 365a 00
6c 308b 00
6c 0100 01

```

7.4 AC characteristics

table 7-4 AC characteristics ($T_A = 25^\circ\text{C}$, $V_{DD-IO} = 2.8\text{V}$)

symbol	parameter	min	typ	max	unit
ADC parameters					
B	analog bandwidth		12		MHz
DLE	DC differential linearity error		0.5		LSB
ILE	DC integral linearity error		1		LSB
	settling time for hardware reset			<1	ms
	settling time for software reset			<1	ms
	settling time for resolution mode change			<1	ms
	settling time for register setting			<300	ms

table 7-5 timing characteristics

symbol	parameter	min	typ	max	unit
clock input					
f_{osc}	frequency (XVCLK) ^a	6	24	27	MHz
t_r , t_f	clock input rise/fall time			(see footnote ^b)	ns
	clock input duty cycle	45	50	55	%

- a. for input clock range 6~27MHz, the OV9734/OV9234 can tolerate input clock period jitter up to 600ps peak-to-peak
 b. for clock input rise/fall time, max is 27% of whole clock period

Confidential for
TIANQIN only

8 mechanical specifications

8.1 physical specifications

figure 8-1 package specifications

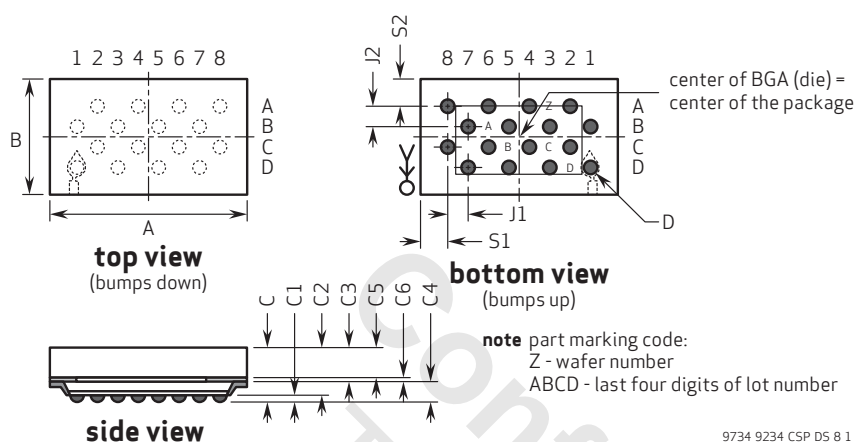
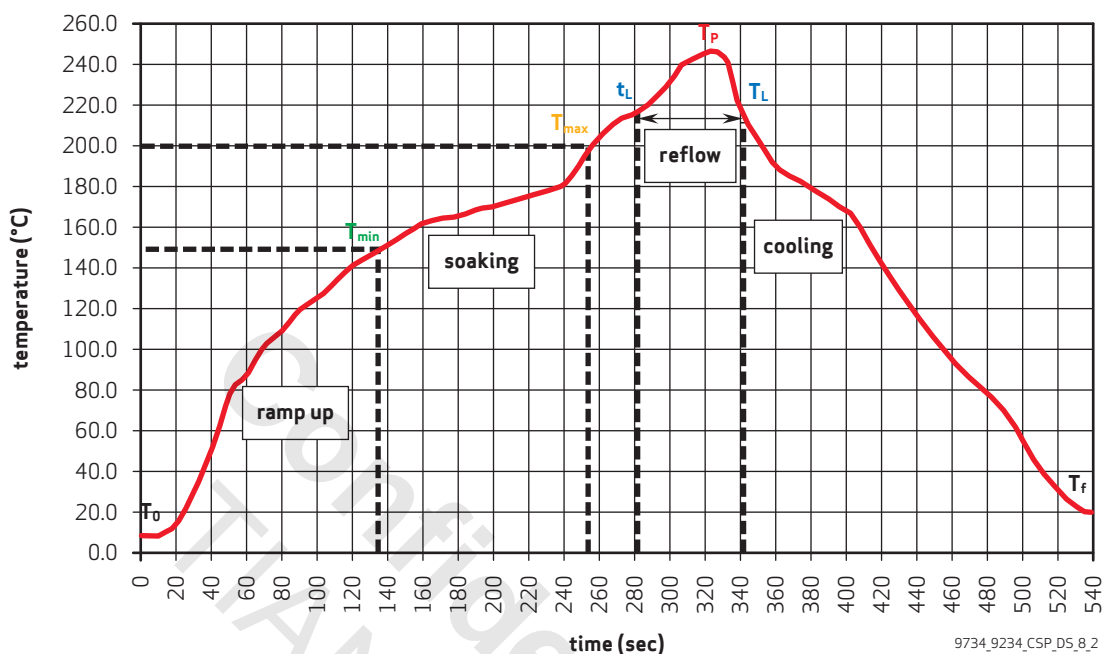

table 8-1 package dimensions

parameter	symbol	min	typ	max	unit
package body dimension x	A	2507	2532	2557	μm
package body dimension y	B	1697	1722	1747	μm
package height	C	680	740	800	μm
ball height	C1	100	130	160	μm
package body thickness	C2	575	610	645	μm
thickness of glass surface to wafer	C3	425	445	465	μm
image plane height	C4	250	295	340	μm
glass thickness	C5	385	400	415	μm
air gap between sensor and glass	C6	41	45	49	μm
ball diameter	D	190	220	250	μm
total ball count	N		16		
pins pitch x-axis	J1		275		μm
pins pitch y-axis	J2		305		μm
edge-to-pin center distance along x	S1	273.5	303.5	333.5	μm
edge-to-pin center distance along y	S2	373.5	403.5	433.5	μm

8.2 IR reflow specifications

figure 8-2 IR reflow ramp rate requirements



note
The OV9734/OV9234 uses a lead free package.

table 8-2 reflow conditions^{ab}

zone	description	exposure
ramp up A (T_0 to T_{min})	heating from room temperature to 150°C	temperature slope $\leq 3^\circ\text{C}$ per second
soaking	heating from 150°C to 200°C	90 ~ 150 seconds
ramp up B (t_L to T_P)	heating from 217°C to 245°C	temperature slope $\leq 3^\circ\text{C}$ per second
peak temperature	maximum temperature in SMT	245°C $\pm 0/-5^\circ\text{C}$ (duration max 30 sec)
reflow (t_L to T_L)	temperature higher than 217°C	30 ~ 120 seconds
ramp down A (T_P to T_L)	cooling down from 245°C to 217°C	temperature slope $\leq 3^\circ\text{C}$ per second
ramp down B (T_L to T_f)	cooling down from 217°C to room temperature	temperature slope $\leq 2^\circ\text{C}$ per second
T_0 to T_P	room temperature to peak temperature	≤ 8 minutes

- a. maximum number of reflow cycles = 3
- b. N2 gas reflow or control O2 gas PPM <500 as recommendation

9 optical specifications

9.1 sensor array center

figure 9-1 sensor array center

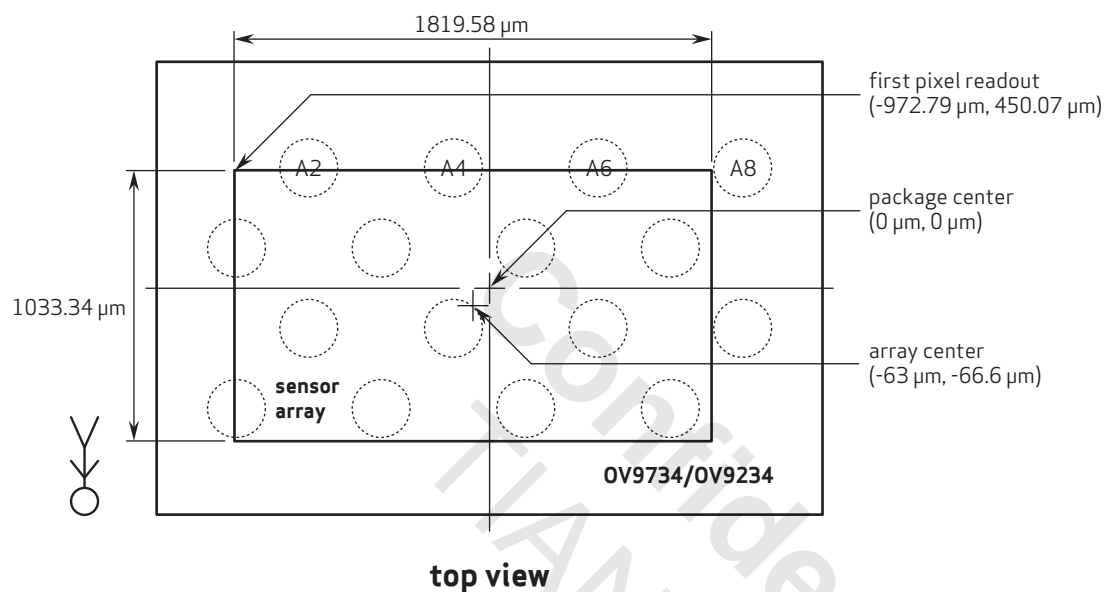

note 1 this drawing is not to scale and is for reference only.

note 2 as most optical assemblies invert and mirror the image, the chip is typically mounted with pins A2 to A8 oriented down on the PCB.

9734_9234_CSP_D5_9_1

9.2 lens chief ray angle (CRA)

figure 9-2 chief ray angle (CRA)

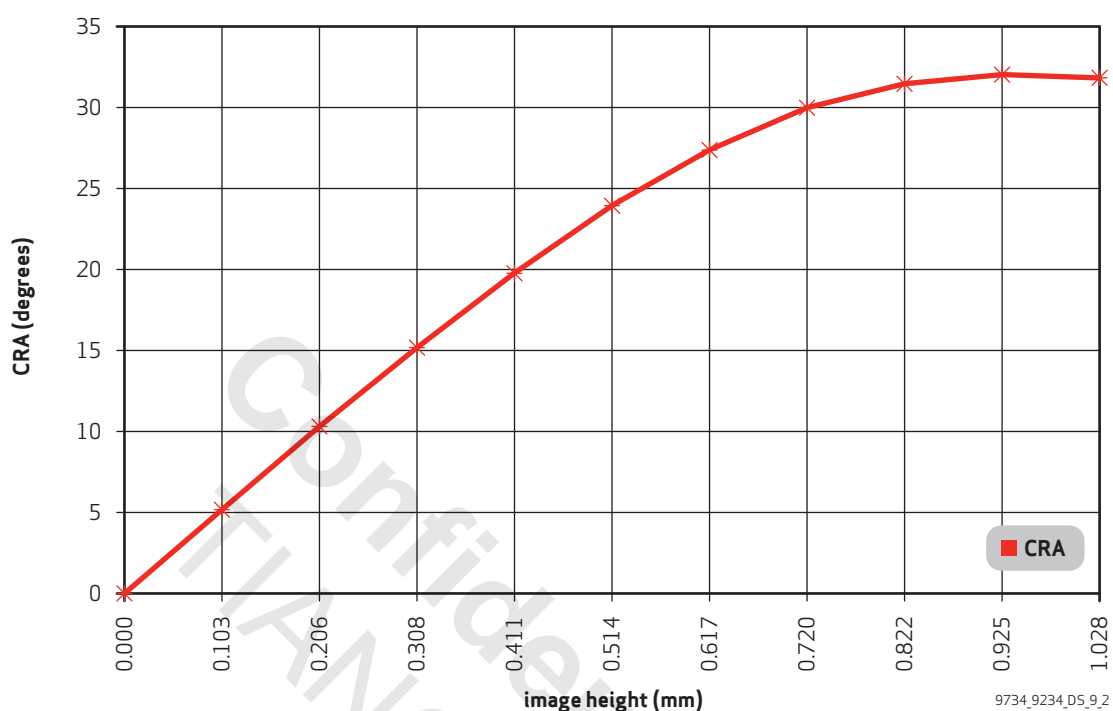

table 9-1 CRA versus image height plot

field (%)	image height (mm)	CRA (degrees)
0	0	0
0.1	0.103	5.2
0.2	0.206	10.3
0.3	0.308	15.2
0.4	0.411	19.8
0.5	0.514	24.0
0.6	0.617	27.4
0.7	0.720	30.0
0.8	0.822	31.5
0.9	0.925	32.1
1.0	1.028	31.9

revision history

- version 1.0** **12.17.2014**
- initial release
- version 1.01** **03.03.2015**
- changed all instances of OmniPixel3-HS to PureCel
 - in chapter 2, changed first sentence to "The OV9734 color PureCel™ image sensor is a low voltage, high-performance 1/9-inch 720p CMOS image sensor that provides the full functionality of a single chip, 720p (1280x720) and VGA (640x480) camera."
 - in figure 9-1, updated first pixel coordinates
- version 1.02** **07.02.2015**
- in ordering information, added b&w ordering part number information
 - added b&w part number throughout datasheet
- version 1.1** **10.14.2015**
- in section 2-2, updated figure 2-2
 - in table 2-1, changed description of register bits 0x3009[6:5] to "output drive capability for MIPI" and changed function of register 0x3001 to "MIPI I/O control"
 - in chapter 2, added section 2.11
 - in table 6-3, removed row for register 0x3009
 - in table 6-4, removed row for register 0x301E
 - in section 6.9, added sidebar note, "For optimal performance, minimum exposure should be 4 lines. For more details, contact your local OmniVision FAE."
 - in table 7-2, changed operating temperature range to -30°C to +85°C junction temperature
 - in table 7-3, changed title to "DC characteristics (-30°C < T_J < 85°C)"
- version 1.11** **12.09.2015**
- in section 2.9, added figure 2-5

version 1.12

01.14.2016

- in key specifications, removed I_{DD-A} , I_{DD-D} , and I_{DD-IO} specifications under power requirements, added active power requirements specification (70 mW), and added sidebar note, "Active power requirement specification is an estimated value and is subject to change when measured data using"
- in table 7-3, changed typ value for I_{DD-A} , I_{DD-D} , and I_{DD-IO} to 16.5mA, 16.6mA, and 2mA, respectively, removed all TBDs from max column, and added sidebar note, "Typical values for I_{DD-A} , I_{DD-D} , and I_{DD-IO} are estimated values and are subject to change when measured data using real silicon is available."

version 1.2

03.01.2016

- in key specifications, changed XSHUTDN power requirements specification to 0.9 μ W and changed sidebar note to "Power requirements specifications are estimated values ..."
- in key specifications, changed sensitivity to 585 mV/Lux-sec, max S/N ratio to 36.4 dB, dynamic range to 68.4 dB @ 16x gain, and dark current to $2e^-$ /sec @ 50°C junction temperature
- in table 4-3, added table footnote a, "1x gain and maximum (15.5x) gain of analog_gain[9:0] is 0x10 and 0xF8, respectively"
- in table 6-18, added table footnote a, "1x gain and maximum (~4x) gain of mwb_x_gain[11:0] is 0x100 and 0x3FF, respectively"
- in table 7-3, added max values for I_{DD-A} , I_{DD-D} , I_{DD-IO} , $I_{DDS-SCCB}$, and $I_{DDS-XSHUTDN}$
- in table 7-3, changed typ values for $I_{DDS-SCCB}$ and $I_{DDS-XSHUTDN}$ to 60 μ A and 0.5 μ A, respectively
- in table 7-3, changed sidebar note to "Typical and maximum values for I_{DD-A} , I_{DD-D} , I_{DD-IO} , $I_{DDS-SCCB}$, and $I_{DDS-XSHUTDN}$ are estimated values and..."
- in table 7-3, added table footnote a, "standby current is measured at room temperature with external clock. Use the registers below to get minimum standby current, which controls more registers than only the 0x0100..."
- in table 7-5, removed "oscillator and" from row heading, changed max values for t_p , t_f to "(see footnote b) and added table footnote a, "for input clock range 6~27MHz, the OV9734 can tolerate input clock period jitter up to 600ps peak-to-peak"

version 1.3

05.19.2016

- in features, changed second bullet point from "...RAW output with MIPI" to "...RAW output with 1-lane MIPI"
- in key specifications, removed side bar note for power requirements, changed active power requirements to 69 mW, and changed output formats to "10-bit Raw RGB"
- in table 2-2, removed column for pixel clock, removed "vertical/horizontal digital" from 2x2 binning RGB methodology, changed 2x2 binning RGB MIPI speed from 180 Mbps to 360 Mbps, changed 2x2 binning BW methodology from "vertical neighbor pixels; horizontal neighbor pixels" to "horizontal neighbor pixels binning; vertical neighbor pixels subsampling", and changed 2x2 binning BW MIPI speed from 180 Mbps to 360 Mbps
- in section 3.2, removed second sentence of section description, changed third sentence of section description from "...supports 2x2 binning..." to "...supports 2x2 RGB binning...", removed "where the voltage levels..." from third sentence of section description, added "and BW binning (horizontal binning only..." to end of section description, changed figure 3-2 title from "example of 2x2 binning" to "example of 2x2 RGB binning", and added new figure 3-3

- in table 3-1, added register 0x37C0
- in table 4-1, added bit description for 0x3820[4]
- in table 5-1, changed bit description for 0x5000[5] to "Reserved"
- in table 6-15, changed bit description for 0x5000[5] to "Reserved"
- in table 6-1, added sidebar note and added bit description for 0x3820[4]
- in chapter 6, added new section 6.6
- in table 6-9, added bit description for 0x3820[4]
- in chapter 6, removed sections 6.13 and 6.14
- in table 6-14, changed bit description for 0x5000[5] to "Reserved"
- in chapter 6, removed section 6.16
- in section 7.3, removed sidebar note
- in table 7-3, changed I_{DD-A} active (operating) current from 16.5 mA, 22 mA to 18.5, 35 mA, respectively, I_{DD-D} active (operating) current from 16.6 mA, 21 mA to 12, 16 mA, respectively, I_{DD-IO} active (operating) current from 2 mA, 2.6 mA to 1.5, 2.2 mA, respectively, $I_{DDS-SCCB}$ maximum standby current from 2000 μ A to 1500 μ A, changed table footnote a from "...temperature with external clock..." to "temperature with external clock off...", and removed table footnote b

version 1.31 06.09.2016

- in header throughout datasheet, added "/OV9234"
- in cover, added "/OV9234"
- in ordering information, added ordering part number OV09234-GA5A
- in section 2.1, updated first paragraph to include OV9234

version 2.0 07.27.2016

- changed datasheet from Preliminary Specification to Product Specification

version 2.01 05.09.2017

- in section 8.1, updated figure 8-1

Confidential for
TIANQIN only

defining the future of digital imaging™

Confidential for
TIANQIN only

OmniVision Technologies, Inc.

UNITED STATES

4275 Burton Drive
Santa Clara, CA 95054

tel: +1 408 567 3000
fax: +1 408 567 3001
email: sales@ovt.com

UNITED KINGDOM

Hook, Hampshire +44 1256 744 610

GERMANY

Munich +49 89 63 81 99 88

INDIA

Bangalore +91 80 4112 8966

CHINA

Beijing + 86 10 6580 1690
Shanghai + 86 21 6175 9888
+86 21 5774 9288
Shenzhen + 86 755 8384 9733

JAPAN

Yokohama +81 45 478 7977
Kyoto +81 75 708 5352

KOREA

Seoul + 82 2 3472 3769

SINGAPORE +65 6933 1933

TAIWAN

Taipei +886 2 2657 9800
Hsin-chu +886 3 5656688