

XMC4700 / XMC4800

Microcontroller Series
for Industrial Applications

XMC4000 Family

ARM[®] Cortex[®]-M4
32-bit processor core

Data Sheet

V1.1 2018-09

Edition 2018-09

**Published by
Infineon Technologies AG
81726 Munich, Germany**

**© 2018 Infineon Technologies AG
All Rights Reserved.**

Legal Disclaimer

The information given in this document shall in no event be regarded as a guarantee of conditions or characteristics. With respect to any examples or hints given herein, any typical values stated herein and/or any information regarding the application of the device, Infineon Technologies hereby disclaims any and all warranties and liabilities of any kind, including without limitation, warranties of non-infringement of intellectual property rights of any third party.

Information

For further information on technology, delivery terms and conditions and prices, please contact the nearest Infineon Technologies Office (www.infineon.com).

Warnings

Due to technical requirements, components may contain dangerous substances. For information on the types in question, please contact the nearest Infineon Technologies Office.

Infineon Technologies components may be used in life-support devices or systems only with the express written approval of Infineon Technologies, if a failure of such components can reasonably be expected to cause the failure of that life-support device or system or to affect the safety or effectiveness of that device or system. Life support devices or systems are intended to be implanted in the human body or to support and/or maintain and sustain and/or protect human life. If they fail, it is reasonable to assume that the health of the user or other persons may be endangered.

XMC4700 / XMC4800

Microcontroller Series
for Industrial Applications

XMC4000 Family

ARM[®] Cortex[®]-M4
32-bit processor core

Data Sheet

V1.1 2018-09

XMC4[78]00 Data Sheet

Revision History: V1.1 2018-09

Previous Versions:

V1.0 2016-01

V0.7 2015-10 (preliminary)

Page	Subjects
55	Added RMS Noise parameter in VADC Parameters table.
8	Corrected EtherCAT features to 8 Fieldbus Memory Management Units (FMMU) and 8 Sync Manager.
46	Added footnote explaining minimum V_{BAT} requirements to start the hibernate domain and/or oscillation of a crystal on RTC_XTAL.
53	Added HIBIO characteristics.
59	Corrected DAC INL and gain error.
71	Changed frequency dependency of the current consumption.
74	Added peripheral idle current overview.
128ff	Updated package parameters and drawings.
133	Higher HBM and CDM ESD limits.

Trademarks

C166™, TriCore™, XMC™ and DAVE™ are trademarks of Infineon Technologies AG. ARM®, ARM Powered®, Cortex®, Thumb® and AMBA® are registered trademarks of ARM, Limited.

CoreSight™, ETM™, Embedded Trace Macrocell™ and Embedded Trace Buffer™ are trademarks of ARM, Limited.

Synopsys™ is a trademark of Synopsys, Inc.

We Listen to Your Comments

Is there any information in this document that you feel is wrong, unclear or missing? Your feedback will help us to continuously improve the quality of this document. Please send your proposal (including a reference to this document) to:

mcdocu.comments@infineon.com



Table of Contents

1	Summary of Features	8
1.1	Ordering Information	10
1.2	Device Types	10
1.3	Device Type Features	11
1.4	Definition of Feature Variants	13
1.5	Identification Registers	14
2	General Device Information	15
2.1	Logic Symbols	15
2.2	Pin Configuration and Definition	18
2.2.1	Package Pin Summary	21
2.2.2	Port I/O Functions	29
2.2.2.1	Port I/O Function Table	30
2.3	Power Connection Scheme	38
3	Electrical Parameters	40
3.1	General Parameters	40
3.1.1	Parameter Interpretation	40
3.1.2	Absolute Maximum Ratings	41
3.1.3	Pin Reliability in Overload	42
3.1.4	Pad Driver and Pad Classes Summary	45
3.1.5	Operating Conditions	46
3.2	DC Parameters	47
3.2.1	Input/Output Pins	47
3.2.2	Analog to Digital Converters (VADC)	54
3.2.3	Digital to Analog Converters (DAC)	58
3.2.4	Out-of-Range Comparator (ORC)	62
3.2.5	Die Temperature Sensor	64
3.2.6	USB OTG Interface DC Characteristics	65
3.2.7	Oscillator Pins	67
3.2.8	Power Supply Current	71
3.2.9	Flash Memory Parameters	75
3.3	AC Parameters	77
3.3.1	Testing Waveforms	77
3.3.2	Power-Up and Supply Monitoring	78
3.3.3	Power Sequencing	79
3.3.4	Phase Locked Loop (PLL) Characteristics	81
3.3.5	Internal Clock Source Characteristics	82
3.3.6	JTAG Interface Timing	84
3.3.7	Serial Wire Debug Port (SW-DP) Timing	86
3.3.8	Embedded Trace Macro Cell (ETM) Timing	87
3.3.9	Peripheral Timing	88

Table of Contents

3.3.9.1	Delta-Sigma Demodulator Digital Interface Timing	88
3.3.9.2	Synchronous Serial Interface (USIC SSC) Timing	89
3.3.9.3	Inter-IC (IIC) Interface Timing	92
3.3.9.4	Inter-IC Sound (IIS) Interface Timing	94
3.3.9.5	SDMMC Interface Timing	96
3.3.10	EBU Timing	104
3.3.10.1	EBU Asynchronous Timing	104
3.3.10.2	EBU Burst Mode Access Timing	111
3.3.10.3	EBU Arbitration Signal Timing	113
3.3.10.4	EBU SDRAM Access Timing	114
3.3.11	USB Interface Characteristics	118
3.3.12	Ethernet Interface (ETH) Characteristics	119
3.3.12.1	ETH Measurement Reference Points	119
3.3.12.2	ETH Management Signal Parameters (ETH_MDC, ETH_MDIO)	120
3.3.12.3	ETH MII Parameters	121
3.3.12.4	ETH RMII Parameters	122
3.3.13	EtherCAT (ECAT) Characteristics	123
3.3.13.1	ECAT Measurement Reference Points	123
3.3.13.2	ETH Management Signal Parameters (MCLK, MDIO)	123
3.3.13.3	MII Timing TX Characteristics	124
3.3.13.4	MII Timing RX Characteristics	126
3.3.13.5	Sync/Latch Timings	127
4	Package and Reliability	128
4.1	Package Parameters	128
4.1.1	Thermal Considerations	128
4.2	Package Outlines	129
5	Quality Declarations	133

About this Document

This Data Sheet is addressed to embedded hardware and software developers. It provides the reader with detailed descriptions about the ordering designations, available features, electrical and physical characteristics of the XMC4[78]00 series devices.

The document describes the characteristics of a superset of the XMC4[78]00 series devices. For simplicity, the various device types are referred to by the collective term XMC4[78]00 throughout this manual.

XMC4000 Family User Documentation

The set of user documentation includes:

- **Reference Manual**
 - describes the functionality of the superset of devices.
- **Data Sheets**
 - list the complete ordering designations, available features and electrical characteristics of derivative devices.
- **Errata Sheets**
 - list deviations from the specifications given in the related Reference Manual or Data Sheets. Errata Sheets are provided for the superset of devices.

Attention: Please consult all parts of the documentation set to attain consolidated knowledge about your device.

Application related guidance is provided by **Users Guides** and **Application Notes**.

Please refer to <http://www.infineon.com/xmc4000> to get access to the latest versions of those documents.

1 Summary of Features

The XMC4[78]00 devices are members of the XMC4000 Family of microcontrollers based on the ARM Cortex-M4 processor core. The XMC4000 is a family of high performance and energy efficient microcontrollers optimized for Industrial Connectivity, Industrial Control, Power Conversion, Sense & Control.

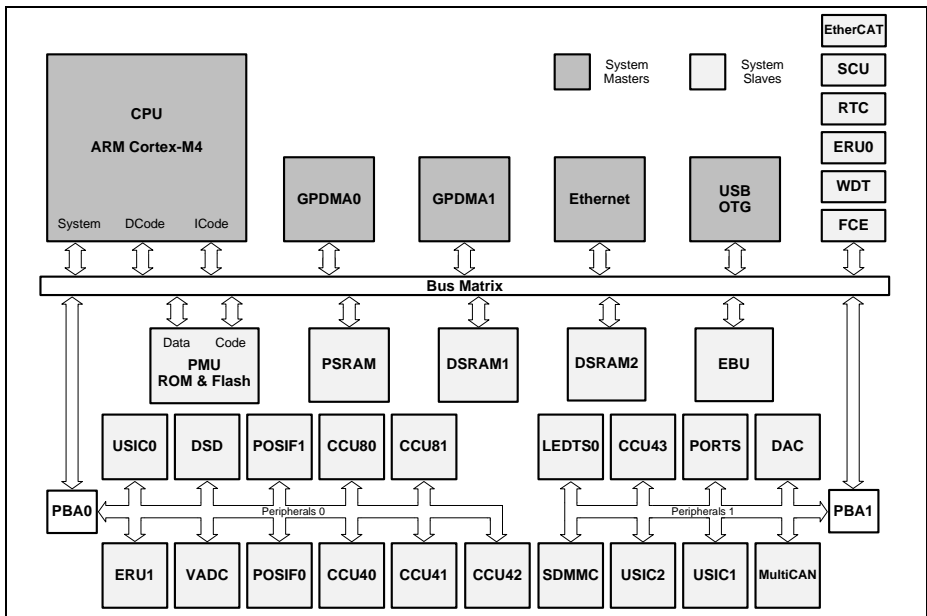

Figure 1 System Block Diagram

CPU Subsystem

- CPU Core
 - High Performance 32-bit ARM Cortex-M4 CPU
 - 16-bit and 32-bit Thumb2 instruction set
 - DSP/MAC instructions
 - System timer (SysTick) for Operating System support
- Floating Point Unit
- Memory Protection Unit
- Nested Vectored Interrupt Controller
- General Purpose DMA with up-to 12 channels
- Event Request Unit (ERU) for programmable processing of external and internal service requests
- Flexible CRC Engine (FCE) for multiple bit error detection

On-Chip Memories

- 16 KB on-chip boot ROM
- 96 KB on-chip high-speed program memory
- 128 KB on-chip high speed data memory
- 128 KB on-chip high-speed communication memory
- 2,048 KB on-chip Flash Memory with 8 KB instruction cache

Communication Peripherals

- Ethernet MAC module capable of 10/100 Mbit/s transfer rates
- EtherCATSlave interface (ECAT) capable of 100 Mbit/s transfer rates with 2 MII ports, 8 Fieldbus Memory Management Units (FMMU), 8 Sync Manager, 64 bit distributed clocks
- Universal Serial Bus, USB 2.0 host, Full-Speed OTG, with integrated PHY
- Controller Area Network interface (MultiCAN), Full-CAN/Basic-CAN with 6 nodes, 256 message objects (MO), data rate up to 1 MBaud
- Six Universal Serial Interface Channels (USIC), providing 6 serial channels, usable as UART, double-SPI, quad-SPI, IIC, IIS and LIN interfaces
- LED and Touch-Sense Controller (LEDTS) for Human-Machine interface
- SD and Multi-Media Card interface (SDMMC) for data storage memory cards
- External Bus Interface Unit (EBU) enabling communication with external memories and off-chip peripherals

Analog Frontend Peripherals

- Four Analog-Digital Converters (VADC) of 12-bit resolution, 8 channels each, with input out-of-range comparators
- Delta Sigma Demodulator with four channels, digital input stage for A/D signal conversion
- Digital-Analog Converter (DAC) with two channels of 12-bit resolution

Industrial Control Peripherals

- Two Capture/Compare Units 8 (CCU8) for motor control and power conversion
- Four Capture/Compare Units 4 (CCU4) for use as general purpose timers
- Two Position Interfaces (POSIF) for servo motor positioning
- Window Watchdog Timer (WDT) for safety sensitive applications
- Die Temperature Sensor (DTS)
- Real Time Clock module with alarm support
- System Control Unit (SCU) for system configuration and control

Input/Output Lines

- Programmable port driver control module (PORTS)
- Individual bit addressability

- Tri-stated in input mode
- Push/pull or open drain output mode
- Boundary scan test support over JTAG interface

On-Chip Debug Support

- Full support for debug features: 8 breakpoints, CoreSight, trace
- Various interfaces: ARM-JTAG, SWD, single wire trace

1.1 Ordering Information

The ordering code for an Infineon microcontroller provides an exact reference to a specific product. The code “XMC4<DDD>-<Z><PPP><T><FFFF>” identifies:

- <DDD> the derivatives function set
- <Z> the package variant
 - E: LFBGA
 - F: LQFP
 - Q: VQFN
- <PPP> package pin count
- <T> the temperature range:
 - F: -40°C to 85°C
 - K: -40°C to 125°C
- <FFFF> the Flash memory size.

For ordering codes for the XMC4[78]00 please contact your sales representative or local distributor.

This document describes several derivatives of the XMC4[78]00 series, some descriptions may not apply to a specific product. Please see [Table 1](#).

For simplicity the term **XMC4[78]00** is used for all derivatives throughout this document.

1.2 Device Types

These device types are available and can be ordered through Infineon’s direct and/or distribution channels.

Table 1 Synopsis of XMC4[78]00 Device Types

Derivative¹⁾	Package	Flash Kbytes	SRAM Kbytes
XMC4700-E196x2048	PG-LFBGA-196	2048	352
XMC4700-F144x2048	PG-LQFP-144	2048	352
XMC4700-F100x2048	PG-LQFP-100	2048	352
XMC4700-E196x1536	PG-LFBGA-196	1536	276

Summary of Features
Table 1 Synopsis of XMC4[78]00 Device Types (cont'd)

Derivative ¹⁾	Package	Flash Kbytes	SRAM Kbytes
XMC4700-F144x1536	PG-LQFP-144	1536	276
XMC4700-F100x1536	PG-LQFP-100	1536	276
XMC4800-E196x2048	PG-LFBGA-196	2048	352
XMC4800-F144x2048	PG-LQFP-144	2048	352
XMC4800-F100x2048	PG-LQFP-100	2048	352
XMC4800-E196x1536	PG-LFBGA-196	1536	276
XMC4800-F144x1536	PG-LQFP-144	1536	276
XMC4800-F100x1536	PG-LQFP-100	1536	276
XMC4800-E196x1024	PG-LFBGA-196	1024	200
XMC4800-F144x1024	PG-LQFP-144	1024	200
XMC4800-F100x1024	PG-LQFP-100	1024	200

1) x is a placeholder for the supported temperature range.

1.3 Device Type Features

The following table lists the available features per device type.

Table 2 Features of XMC4[78]00 Device Types

Derivative ¹⁾	LED TS Intf.	SD MMC Intf.	EBU Intf. ²⁾	ETH Intf. ³⁾	ECAT Slave Intf.	USB Intf.	USIC Chan.	MultiCAN Nodes, MO
XMC4700-E196x2048	1	1	SDM	MR	-	1	3 x 2	N[0..5] MO[0..255]
XMC4700-F144x2048	1	1	SDM	MR	-	1	3 x 2	N[0..5] MO[0..255]
XMC4700-F100x2048	1	1	M16	R	-	1	3 x 2	N[0..5] MO[0..255]
XMC4700-E196x1536	1	1	SDM	MR	-	1	3 x 2	N[0..5] MO[0..255]
XMC4700-F144x1536	1	1	SDM	MR	-	1	3 x 2	N[0..5] MO[0..255]
XMC4700-F100x1536	1	1	M16	R	-	1	3 x 2	N[0..5] MO[0..255]

Summary of Features
Table 2 Features of XMC4[78]00 Device Types (cont'd)

Derivative ¹⁾	LED TS Intf.	SD MMC Intf.	EBU Intf. ²⁾	ETH Intf. ³⁾	ECAT Slave Intf.	USB Intf.	USIC Chan.	MultiCAN Nodes, MO
XMC4800-E196x2048	1	1	SDM	MR	2 x MII	1	3 x 2	N[0..5] MO[0..255]
XMC4800-F144x2048	1	1	SDM	MR	2 x MII	1	3 x 2	N[0..5] MO[0..255]
XMC4800-F100x2048	1	1	M16	R	2 x MII	1	3 x 2	N[0..5] MO[0..255]
XMC4800-E196x1536	1	1	SDM	MR	2 x MII	1	3 x 2	N[0..5] MO[0..255]
XMC4800-F144x1536	1	1	SDM	MR	2 x MII	1	3 x 2	N[0..5] MO[0..255]
XMC4800-F100x1536	1	1	M16	R	2 x MII	1	3 x 2	N[0..5] MO[0..255]
XMC4800-E196x1024	1	1	SDM	MR	2 x MII	1	3 x 2	N[0..5] MO[0..255]
XMC4800-F144x1024	1	1	SDM	MR	2 x MII	1	3 x 2	N[0..5] MO[0..255]
XMC4800-F100x1024	1	1	M16	R	2 x MII	1	3 x 2	N[0..5] MO[0..255]

1) x is a placeholder for the supported temperature range.

2) Memory types supported S=SDRAM, D=DEMUX, M=MUX 16-bit and 32-bit, M16=MUX 16-bit

3) Supported interfaces, M=MII, R=RMII.

Table 3 Features of XMC4[78]00 Device Types

Derivative ¹⁾	ADC Chan.	DSD Chan.	DAC Chan.	CCU4 Slice	CCU8 Slice	POSIF Intf.
XMC4700-E196x2048	32	4	2	4 x 4	2 x 4	2
XMC4700-F144x2048	32	4	2	4 x 4	2 x 4	2
XMC4700-F100x2048	24	4	2	4 x 4	2 x 4	2
XMC4700-E196x1536	32	4	2	4 x 4	2 x 4	2
XMC4700-F144x1536	32	4	2	4 x 4	2 x 4	2
XMC4700-F100x1536	24	4	2	4 x 4	2 x 4	2
XMC4800-E196x2048	32	4	2	4 x 4	2 x 4	2

Summary of Features

Table 3 Features of XMC4[78]00 Device Types (cont'd)

Derivative ¹⁾	ADC Chan.	DSD Chan.	DAC Chan.	CCU4 Slice	CCU8 Slice	POSIF Intf.
XMC4800-F144x2048	32	4	2	4 x 4	2 x 4	2
XMC4800-F100x2048	24	4	2	4 x 4	2 x 4	2
XMC4800-E196x1536	32	4	2	4 x 4	2 x 4	2
XMC4800-F144x1536	32	4	2	4 x 4	2 x 4	2
XMC4800-F100x1536	24	4	2	4 x 4	2 x 4	2
XMC4800-E196x1024	32	4	2	4 x 4	2 x 4	2
XMC4800-F144x1024	32	4	2	4 x 4	2 x 4	2
XMC4800-F100x1024	24	4	2	4 x 4	2 x 4	2

1) x is a placeholder for the supported temperature range.

1.4 Definition of Feature Variants

The XMC4[78]00 types are offered with several memory sizes and number of available VADC channels. [Table 4](#) describes the location of the available Flash memory, [Table 5](#) describes the location of the available SRAMs, [Table 6](#) the available VADC channels.

Table 4 Flash Memory Ranges

Total Flash Size	Cached Range	Uncached Range
1,024 Kbytes	0800 0000 _H – 080F FFFF _H	0C00 0000 _H – 0C0F FFFF _H
1,536 Kbytes	0800 0000 _H – 0817 FFFF _H	0C00 0000 _H – 0C17 FFFF _H
2,048 Kbytes	0800 0000 _H – 081F FFFF _H	0C00 0000 _H – 0C1F FFFF _H

Table 5 SRAM Memory Ranges

Total SRAM Size	Program SRAM	System Data SRAM	Communication Data SRAM
200 Kbytes	1FFE E000 _H – 1FFF FFFF _H	2000 0000 _H – 2001 FFFF _H	–
276 Kbytes	1FFE 8000 _H – 1FFF FFFF _H	2000 0000 _H – 2001 FFFF _H	2002 0000 _H – 2002 CFFF _H
352 Kbytes	1FFE 8000 _H – 1FFF FFFF _H	2000 0000 _H – 2001 FFFF _H	2002 0000 _H – 2003 FFFF _H

Table 6 ADC Channels¹⁾

Package	VADC G0	VADC G1	VADC G2	VADC G3
PG-LQFP-144 PG-LFBGA-196	CH0..CH7	CH0..CH7	CH0..CH7	CH0..CH7
PG-LQFP-100	CH0..CH7	CH0..CH7	CH0..CH3	CH0..CH3

1) Some pins in a package may be connected to more than one channel. For the detailed mapping see the Port I/O Function table.

1.5 Identification Registers

The identification registers allow software to identify the marking.

Table 7 XMC4700 Identification Registers

Register Name	Value	Marking
SCU_IDCHIP	0004 7001 _H	EES-AA, ES-AA, AA
JTAG IDCODE	101D F083 _H	EES-AA, ES-AA, AA

Table 8 XMC4800 Identification Registers

Register Name	Value	Marking
SCU_IDCHIP	0004 8001 _H	EES-AA, ES-AA, AA
JTAG IDCODE	101D F083 _H	EES-AA, ES-AA, AA

2 General Device Information

This section summarizes the logic symbols and package pin configurations with a detailed list of the functional I/O mapping.

2.1 Logic Symbols

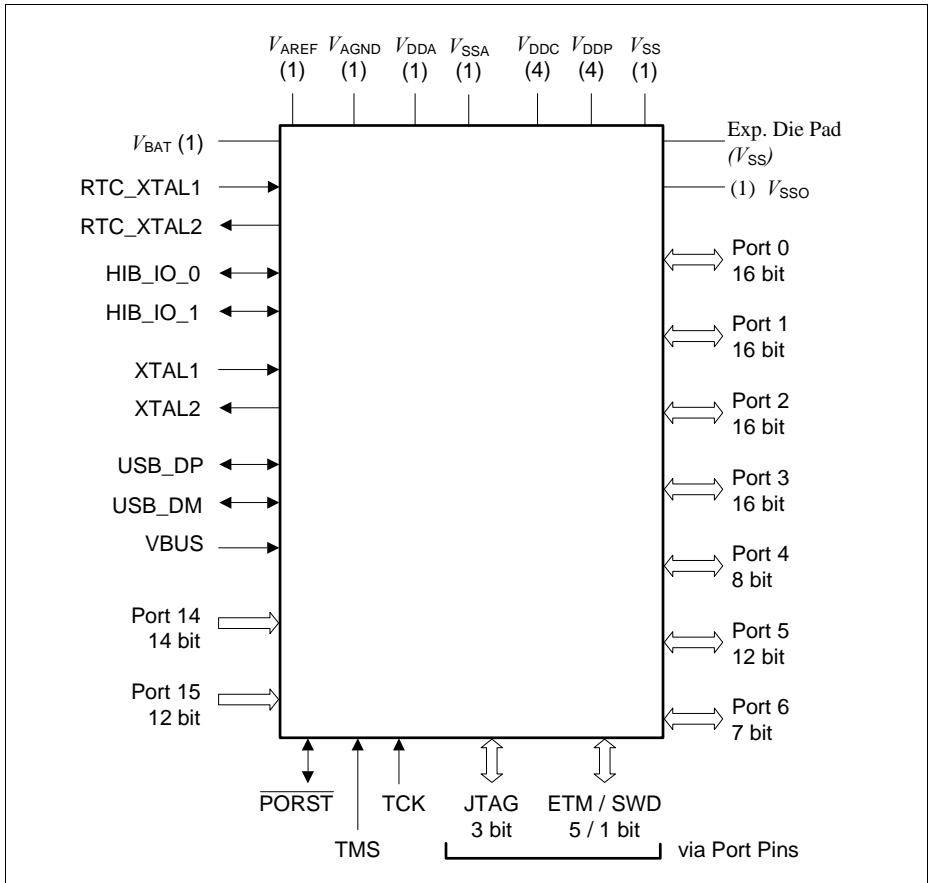

Figure 2 XMC4[78]00 Logic Symbol PG-LQFP-144

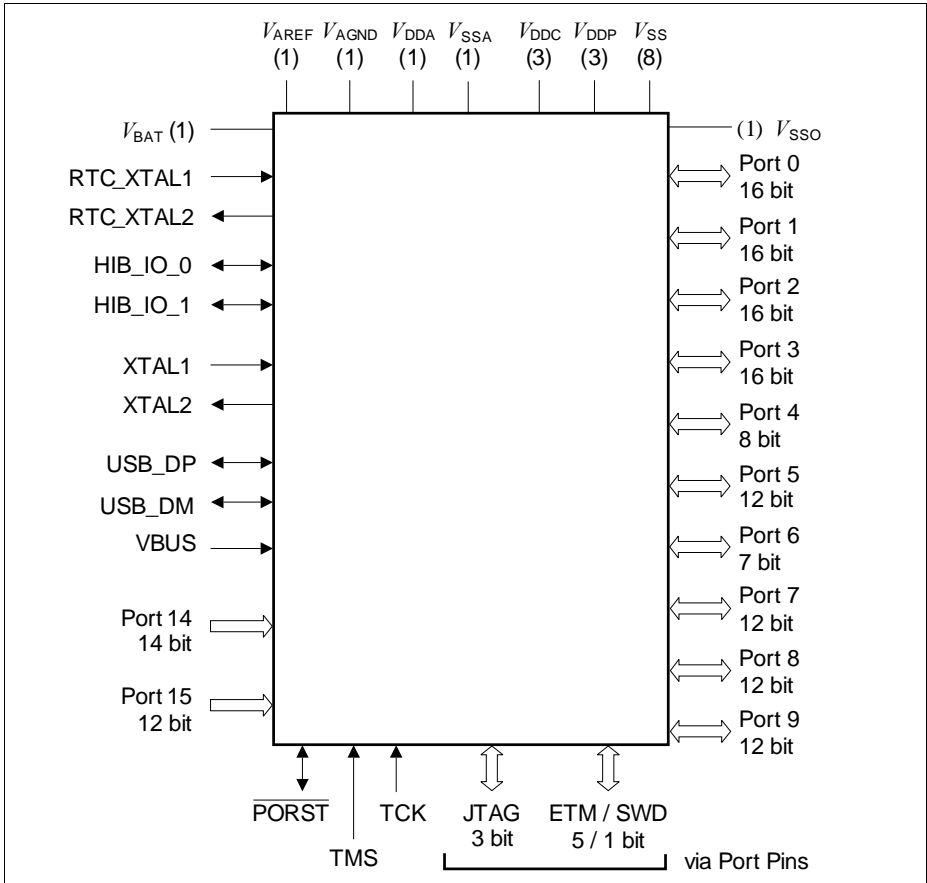

Figure 3 XMC4[78]00 Logic Symbol PG-LFBGA-196

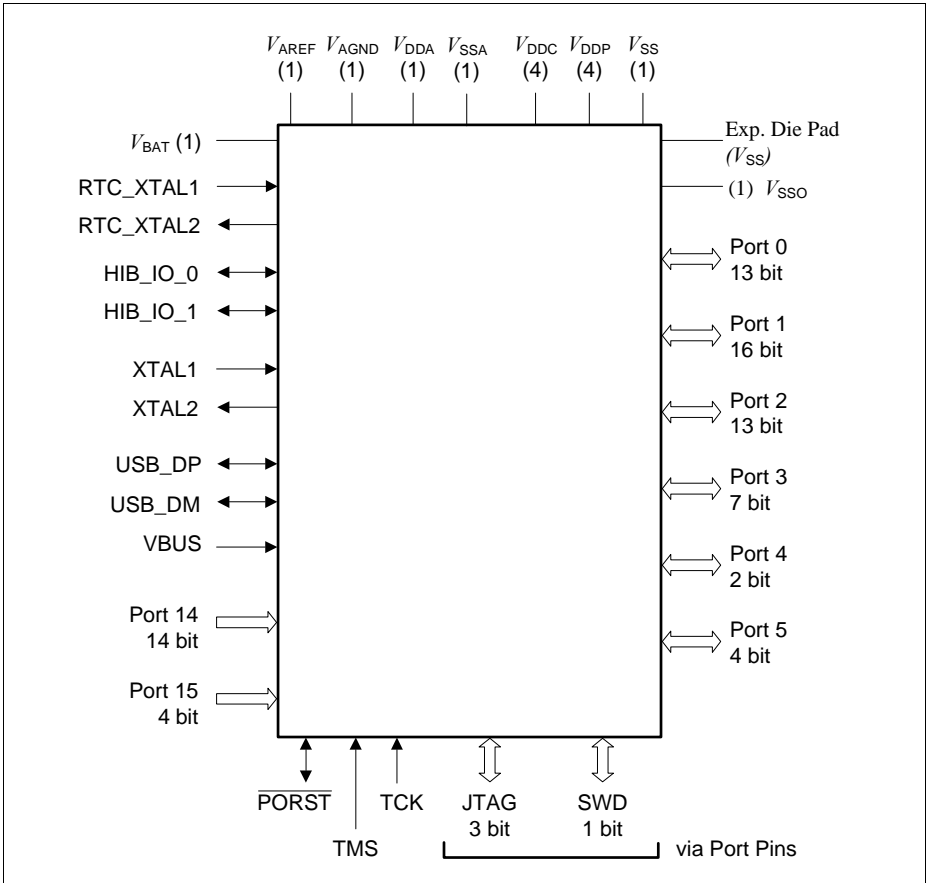

Figure 4 XMC4[78]00 Logic Symbol PG-LQFP-100

General Device Information

	1	2	3	4	5	6	7	8	9	10	11	12	13	14	
A	VSS	P8.6	P8.8	P8.10	P8.9	P8.11	P8.1	P9.8	P9.7	P9.9	P9.5	P9.4	n.c.	VSS	A
B	n.c.	P8.3	P8.2	P8.7	P8.5	P8.4	P8.0	P9.10	P9.11	n.c.	P9.6	n.c.	VSS	n.c.	B
C	VSS	VDDC	P0.2	P0.3	P0.5	P0.6	P3.6	P0.8	P4.1	P1.8	VDDP	VSS	n.c.	n.c.	C
D	VDDP	P3.1	P3.2	P0.10	P0.4	P3.5	P0.7	P4.0	P1.6	P1.7	P1.9	VDDC	P9.3	P9.2	D
E	P3.0	P3.13	P0.1	P0.0	P0.13	P0.15	P4.4	P4.6	P4.7	P1.4	P1.2	P1.3	n.c.	P9.1	E
F	USB_D M	P3.12	P3.11	P0.9	P0.12	P3.14	P3.15	P4.5	P1.0	P1.5	P1.11	P1.10	P9.0	P7.11	F
G	USB_D P	VBUS	P3.8	P3.7	P0.11	P0.14	P3.4	P4.2	P1.1	P1.14	P1.12	P1.13	P7.9	P7.10	G
H	RTC_X TAL1	RTC_X TAL2	HIB_I O_1	HIB_I O_0	P3.9	P3.10	P3.3	P4.3	P6.1	P6.4	P6.5	P6.6	n.c.	P7.8	H
J	VBAT	P15.3	P15.5	P15.4	P15.6	P15.7	TMS	TCK	P6.3	P6.0	$\overline{\text{PORST}}$	P1.15	n.c.	P7.7	J
K	P15.2	P14.15	P14.14	P14.13	P5.10	P5.8	P5.2	P5.1	P5.0	P6.2	XTAL1	XTAL2	n.c.	P7.6	K
L	P14.12	P14.7	P14.6	P14.3	P5.11	P2.15	P5.7	P5.5	P2.6	P5.3	P2.0	VSSO	P7.0	P7.5	L
M	P14.4	P14.5	P14.2	P15.15	P15.12	P5.9	P2.14	P5.6	P2.7	P5.4	P2.2	P2.1	P7.1	P7.3	M
N	VDDA	P14.1	P14.0	P15.14	P14.9	P15.9	P2.12	P2.10	P2.8	P2.4	P2.3	VDDP	P7.2	P7.4	N
P	VSSA	VAGND	VAREF	P15.13	P14.8	P15.8	P2.13	P2.11	P2.9	P2.5	VDDC	VSS	n.c.	VSS	P
	1	2	3	4	5	6	7	8	9	10	11	12	13	14	

XMC4[78]00 - (top view)

Figure 6 XMC4[78]00 PG-LFBGA-196 Pin Configuration (top view)

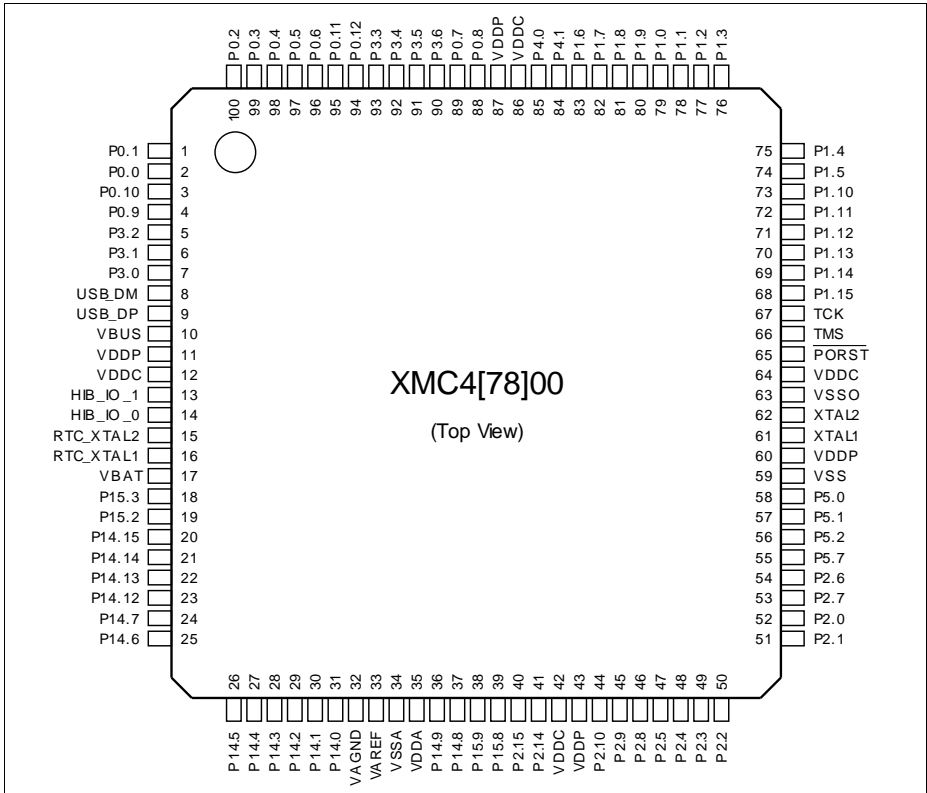

Figure 7 XMC4[78]00 PG-LQFP-100 Pin Configuration (top view)

2.2.1 Package Pin Summary

The following general scheme is used to describe each pin:

Table 9 Package Pin Mapping Description

Function	Package A	Package B	...	Pad Type	Notes
Name	N	Ax	...	A2	

The table is sorted by the “Function” column, starting with the regular Port pins (Px.y), followed by the dedicated pins (i.e. PORST) and supply pins.

The following columns, titled with the supported package variants, lists the package pin number to which the respective function is mapped in that package.

The “Pad Type” indicates the employed pad type (A1, A1+, A2, special=special pad, In=input pad, AN/DIG_IN=analog and digital input, Power=power supply). Details about the pad properties are defined in the Electrical Parameters.

In the “Notes”, special information to the respective pin/function is given, i.e. deviations from the default configuration after reset. Per default the regular Port pins are configured as direct input with no internal pull device active.

Table 10 Package Pin Mapping

Function	LFBGA-196	LQFP-144	LQFP-100	Pad Type	Notes
P0.0	E4	2	2	A1+	
P0.1	E3	1	1	A1+	
P0.2	C3	144	100	A2	
P0.3	C4	143	99	A2	
P0.4	D5	142	98	A2	
P0.5	C5	141	97	A2	
P0.6	C6	140	96	A2	
P0.7	D7	128	89	A2	After a system reset, via HWSEL this pin selects the DB.TDI function.
P0.8	C8	127	88	A2	After a system reset, via HWSEL this pin selects the DB.TRST function, with a weak pull-down active.
P0.9	F4	4	4	A2	
P0.10	D4	3	3	A1+	

General Device Information
Table 10 Package Pin Mapping (cont'd)

Function	LFBGA-196	LQFP-144	LQFP-100	Pad Type	Notes
P0.11	G5	139	95	A1+	
P0.12	F5	138	94	A1+	
P0.13	E5	137	-	A1+	
P0.14	G6	136	-	A1+	
P0.15	E6	135	-	A1+	
P1.0	F9	112	79	A1+	
P1.1	G9	111	78	A1+	
P1.2	E11	110	77	A2	
P1.3	E12	109	76	A2	
P1.4	E10	108	75	A1+	
P1.5	F10	107	74	A1+	
P1.6	D9	116	83	A2	
P1.7	D10	115	82	A2	
P1.8	C10	114	81	A2	
P1.9	D11	113	80	A2	
P1.10	F12	106	73	A1+	
P1.11	F11	105	72	A1+	
P1.12	G11	104	71	A2	
P1.13	G12	103	70	A2	
P1.14	G10	102	69	A2	
P1.15	J12	94	68	A2	
P2.0	L11	74	52	A2	
P2.1	M12	73	51	A2	After a system reset, via HWSEL this pin selects the DB.TDO function.
P2.2	M11	72	50	A2	
P2.3	N11	71	49	A2	
P2.4	N10	70	48	A2	
P2.5	P10	69	47	A2	
P2.6	L9	76	54	A1+	
P2.7	M9	75	53	A1+	
P2.8	N9	68	46	A2	
P2.9	P9	67	45	A2	

General Device Information

Table 10 Package Pin Mapping (cont'd)

Function	LFBGA-196	LQFP-144	LQFP-100	Pad Type	Notes
P2.10	N8	66	44	A2	
P2.11	P8	65	-	A2	
P2.12	N7	64	-	A2	
P2.13	P7	63	-	A2	
P2.14	M7	60	41	A2	
P2.15	L6	59	40	A2	
P3.0	E1	7	7	A2	
P3.1	D2	6	6	A2	
P3.2	D3	5	5	A2	
P3.3	H7	132	93	A1+	
P3.4	G7	131	92	A1+	
P3.5	D6	130	91	A2	
P3.6	C7	129	90	A2	
P3.7	G4	14	-	A1+	
P3.8	G3	13	-	A1+	
P3.9	H5	12	-	A1+	
P3.10	H6	11	-	A1+	
P3.11	F3	10	-	A1+	
P3.12	F2	9	-	A2	
P3.13	E2	8	-	A2	
P3.14	F6	134	-	A1+	
P3.15	F7	133	-	A1+	
P4.0	D8	124	85	A2	
P4.1	C9	123	84	A2	
P4.2	G8	122	-	A1+	
P4.3	H8	121	-	A1+	
P4.4	E7	120	-	A1+	
P4.5	F8	119	-	A1+	
P4.6	E8	118	-	A1+	
P4.7	E9	117	-	A1+	
P5.0	K9	84	58	A1+	
P5.1	K8	83	57	A1+	
P5.2	K7	82	56	A1+	

General Device Information

Table 10 Package Pin Mapping (cont'd)

Function	LFBGA-196	LQFP-144	LQFP-100	Pad Type	Notes
P5.3	L10	81	-	A2	
P5.4	M10	80	-	A2	
P5.5	L8	79	-	A2	
P5.6	M8	78	-	A2	
P5.7	L7	77	55	A1+	
P5.8	K6	58	-	A2	
P5.9	M6	57	-	A2	
P5.10	K5	56	-	A1+	
P5.11	L5	55	-	A1+	
P6.0	J10	101	-	A2	
P6.1	H9	100	-	A2	
P6.2	K10	99	-	A2	
P6.3	J9	98	-	A1+	
P6.4	H10	97	-	A2	
P6.5	H11	96	-	A2	
P6.6	H12	95	-	A2	
P7.0	L13	-	-	A2	
P7.1	M13	-	-	A2	
P7.2	N13	-	-	A2	
P7.3	M14	-	-	A2	
P7.4	N14	-	-	A1+	
P7.5	L14	-	-	A1+	
P7.6	K14	-	-	A1+	
P7.7	J14	-	-	A1+	
P7.8	H14	-	-	A2	
P7.9	G13	-	-	A1+	
P7.10	G14	-	-	A1+	
P7.11	F14	-	-	A1+	
P8.0	B7	-	-	A2	
P8.1	A7	-	-	A2	
P8.2	B3	-	-	A2	
P8.3	B2	-	-	A2	
P8.4	B6	-	-	A1+	

General Device Information

Table 10 Package Pin Mapping (cont'd)

Function	LFBGA-196	LQFP-144	LQFP-100	Pad Type	Notes
P8.5	B5	-	-	A1+	
P8.6	A2	-	-	A1+	
P8.7	B4	-	-	A1+	
P8.8	A3	-	-	A2	
P8.9	A5	-	-	A1+	
P8.10	A4	-	-	A1+	
P8.11	A6	-	-	A1+	
P9.0	F13	-	-	A2	
P9.1	E14	-	-	A2	
P9.2	D14	-	-	A1+	
P9.3	D13	-	-	A2	
P9.4	A12	-	-	A1+	
P9.5	A11	-	-	A1+	
P9.6	B11	-	-	A1+	
P9.7	A9	-	-	A1+	
P9.8	A8	-	-	A1+	
P9.9	A10	-	-	A1+	
P9.10	B8	-	-	A1+	
P9.11	B9	-	-	A1+	
P14.0	N3	42	31	AN/DIG_IN	
P14.1	N2	41	30	AN/DIG_IN	
P14.2	M3	40	29	AN/DIG_IN	
P14.3	L4	39	28	AN/DIG_IN	
P14.4	M1	38	27	AN/DIG_IN	
P14.5	M2	37	26	AN/DIG_IN	
P14.6	L3	36	25	AN/DIG_IN	
P14.7	L2	35	24	AN/DIG_IN	
P14.8	P5	52	37	AN/DAC/DI G_IN	
P14.9	N5	51	36	AN/DAC/DI G_IN	
P14.12	L1	34	23	AN/DIG_IN	
P14.13	K4	33	22	AN/DIG_IN	

General Device Information

Table 10 Package Pin Mapping (cont'd)

Function	LFBGA-196	LQFP-144	LQFP-100	Pad Type	Notes
P14.14	K3	32	21	AN/DIG_IN	
P14.15	K2	31	20	AN/DIG_IN	
P15.2	K1	30	19	AN/DIG_IN	
P15.3	J2	29	18	AN/DIG_IN	
P15.4	J4	28	-	AN/DIG_IN	
P15.5	J3	27	-	AN/DIG_IN	
P15.6	J5	26	-	AN/DIG_IN	
P15.7	J6	25	-	AN/DIG_IN	
P15.8	P6	54	39	AN/DIG_IN	
P15.9	N6	53	38	AN/DIG_IN	
P15.12	M5	50	-	AN/DIG_IN	
P15.13	P4	49	-	AN/DIG_IN	
P15.14	N4	44	-	AN/DIG_IN	
P15.15	M4	43	-	AN/DIG_IN	
USB_DP	G1	16	9	special	
USB_DM	F1	15	8	special	
HIB_IO_0	H4	21	14	A1 special	At the first power-up and with every reset of the hibernate domain this pin is configured as open-drain output and drives "0". As output the medium driver mode is active.
HIB_IO_1	H3	20	13	A1 special	At the first power-up and with every reset of the hibernate domain this pin is configured as input with no pull device active. As output the medium driver mode is active.
TCK	J8	93	67	A1	Weak pull-down active.
TMS	J7	92	66	A1+	Weak pull-up active. As output the strong-soft driver mode is active.

General Device Information

Table 10 Package Pin Mapping (cont'd)

Function	LFBGA-196	LQFP-144	LQFP-100	Pad Type	Notes
PORST	J11	91	65	special	Weak pull-up permanently active, strong pull-down controlled by EVR.
XTAL1	K11	87	61	clock_IN	
XTAL2	K12	88	62	clock_O	
RTC_XTAL1	H1	23	16	clock_IN	
RTC_XTAL2	H2	22	15	clock_O	
VBAT	J1	24	17	Power	When VDDP is supplied VBAT has to be supplied as well.
VBUS	G2	17	10	special	
VAREF	P3	46	33	AN_Ref	
VAGND	P2	45	32	AN_Ref	
VDDA	N1	48	35	AN_Power	
VSSA	P1	47	34	AN_Power	
VDDC	-	19	12	Power	
VDDC	-	61	42	Power	
VDDC	-	90	64	Power	
VDDC	-	125	86	Power	
VDDC	C2	-	-	Power	
VDDC	D12	-	-	Power	
VDDC	P11	-	-	Power	
VDDP	-	18	11	Power	
VDDP	-	62	43	Power	
VDDP	-	86	60	Power	
VDDP	-	126	87	Power	
VDDP	C11	-	-	Power	
VDDP	D1	-	-	Power	
VDDP	N12	-	-	Power	
VSS	-	85	59	Power	
VSS	A1	-	-	Power	
VSS	A14	-	-	Power	
VSS	B13	-	-	Power	
VSS	C1	-	-	Power	

General Device Information

Table 10 Package Pin Mapping (cont'd)

Function	LFBGA-196	LQFP-144	LQFP-100	Pad Type	Notes
VSS	C12	-	-	Power	
VSS	P12	-	-	Power	
VSS	P14	-	-	Power	
VSSO	L12	89	63	Power	
VSS	-	Exp. Pad	Exp. Pad	Power	<p>Exposed Die Pad The exposed die pad is connected internally to VSS. For proper operation, it is mandatory to connect the exposed pad directly to the common ground on the board. For thermal aspects, please refer to the Data Sheet. Board layout examples are given in an application note.</p>
n.c.	A13	-	-	Power	
n.c.	B1	-	-	Power	
n.c.	B10	-	-	Power	
n.c.	B12	-	-	Power	
n.c.	B14	-	-	Power	
n.c.	C13	-	-	Power	
n.c.	C14	-	-	Power	
n.c.	E13	-	-	Power	
n.c.	H13	-	-	Power	
n.c.	J13	-	-	Power	
n.c.	K13	-	-	Power	
n.c.	P13	-	-	Power	

2.2.2 Port I/O Functions

The following general scheme is used to describe each Port pin:

Table 11 Port I/O Function Description

Function	Outputs			Inputs		
	ALT1	ALn	HWO0	HWIO	Input	Input
P0.0		MODA.OUT	MODB.OUT	MODB.INA	MODC.INA	
Pn.y	MODA.OUT				MODA.INA	MODC.INB

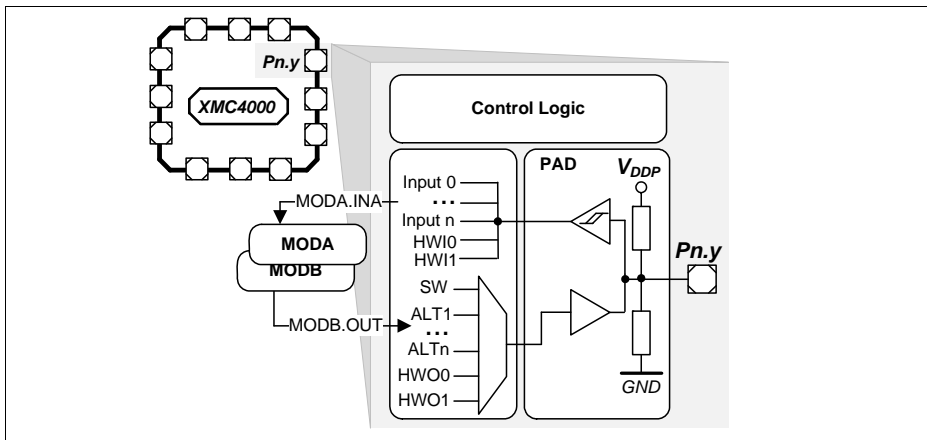

Figure 8 Simplified Port Structure

Pn.y is the port pin name, defining the control and data bits/registers associated with it. As GPIO, the port is under software control. Its input value is read via Pn_IN.y, Pn_OUT defines the output value.

Up to four alternate output functions (ALT1/2/3/4) can be mapped to a single port pin, selected by Pn_IOCR.PC. The output value is directly driven by the respective module, with the pin characteristics controlled by the port registers (within the limits of the connected pad).

The port pin input can be connected to multiple peripherals. Most peripherals have an input multiplexer to select between different possible input sources.

The input path is also active while the pin is configured as output. This allows to feedback an output to on-chip resources without wasting an additional external pin.

By Pn_HWSEL it is possible to select between different hardware “masters” (HWO0/HWIO). The selected peripheral can take control of the pin(s). Hardware control overrules settings in the respective port pin registers.

2.2.2.1 Port I/O Function Table

Table 12 Port I/O Functions

Function	Outputs						Inputs									
	ALT1	ALT2	ALT3	ALT4	HWO0	HWO1	HWI0	HWI1	Input	Input	Input	Input	Input	Input	Input	
P0.0	ECAT0. PHY_RST	CAN. NO_TXD	CCU80. OUT21	LEDT50. COL2					U1C1. DX0D	ETH0. CLK_RMIB	ERU0. 0B0				ETH0. CLKRXB	
P0.1	USB. DRIVEVBUS	U1C1. DOUT0	CCU80. OUT11	LEDT50. COL3						ETH0. CRS_DVB	ERU0. 0A0			ECAT0. P1_RX_CLKA	ETH0. RXDVB	
P0.2	ECAT0. P1_TXD2	U1C1. SELO1	CCU80. OUT01		U1C0. DOUT3	EBU. AD0	U1C0. HWIN3	EBU. D0	ETH0. RXD0B		ERU0. 3B3					
P0.3	ECAT0. P1_TXD3		CCU80. OUT20		U1C0. DOUT2	EBU. AD1	U1C0. HWIN2	EBU. D1	ETH0. RXD1B		ERU1. 3B0					
P0.4	ETH0. TX_EN		CCU80. OUT10		U1C0. DOUT1	EBU. AD2	U1C0. HWIN1	EBU. D2		U1C0. DX0A	ERU0. 2B3			ECAT0. P1_RXD3A		
P0.5	ETH0. TXD0	U1C0. DOUT0	CCU80. OUT00		U1C0. DOUT0	EBU. AD3	U1C0. HWIN0	EBU. D3		U1C0. DX0B		ERU1. 3A0		ECAT0. P1_RXD2A		
P0.6	ETH0. TXD1	U1C0. SELO0	CCU80. OUT30			EBU. ADV				U1C0. DX2A	ERU0. 3B2		CCU80. IN2B	ECAT0. P1_RXD1A		
P0.7	WWDT. SERVICE_OUT	U0C0. SELO0	ECAT0. LED_ERR			EBU. AD6	DB. TDI	EBU. D6	U0C0. DX2B	DSD. DIN1A	ERU0. 2B1		CCU80. IN0A	CCL80. IN1A	CCU80. IN2A	CCU80. IN3A
P0.8	SCU. EXTCLK	U0C0. SCLKOUT	ECAT0. LED_RUN			EBU. AD7	DB. TRST	EBU. D7	U0C0. DX1B	DSD. DIN0A	ERU0. 2A1	CAN. N3_RXDA	CCU80. IN1B			
P0.9		U1C1. SELO0	CCU80. OUT12	LEDT50. COL0	ETH0. MDO	EBU. CST	ETH0. MDIA		U1C1. DX2A	USB. ID	ERU0. 1B0			ECAT0. P1_RX_DVA		
P0.10	ETH0. MDC	U1C1. SCLKOUT	CCU80. OUT02	LEDT50. COL1					U1C1. DX1A		ERU0. 1A0			ECAT0. P1_TX_CLKA		
P0.11	ECAT0. P1_LINK_ACT	U1C0. SCLKOUT	CCU80. OUT31		SDMMC. RST	EBU. BREQ			ETH0. RXERB	U1C0. DX1A	ERU0. 3A2			ECAT0. P1_RXD0A		
P0.12		U1C1. SELO0	CCU40. OUT3		ECAT0. MDO	EBU. HLDA	ECAT0. MDIA	EBU. HLDA		U1C1. DX2B	ERU0. 2B2					
P0.13		U1C1. SCLKOUT	CCU40. OUT2							U1C1. DX1B	ERU0. 2A2					
P0.14		U1C0. SELO1	CCU40. OUT1		U1C1. DOUT3		U1C1. HWIN3						CCU42. IN3C			
P0.15		U1C0. SELO2	CCU40. OUT0		U1C1. DOUT2		U1C1. HWIN2						CCU42. IN2C			
P1.0	DSD. CGPWMM	U0C0. SELO0	CCU40. OUT3	ERU1. PDOUT3					U0C0. DX2A		ERU0. 3B0		CCU40. IN3A	ECAT0. P0_TX_CLKA		
P1.1	DSD. CGPWMP	U0C0. SCLKOUT	CCU40. OUT2	ERU1. PDOUT2			SDMMC. SDWC		U0C0. DX1A	POSIF0. IN2A	ERU0. 3A0		CCU40. IN2A	ECAT0. P0_RX_CLKA		
P1.2	ECAT0. P0_TXD3		CCU40. OUT1	ERU1. PDOUT1	U0C0. DOUT3	EBU. AD14	U0C0. HWIN3	EBU. D14		POSIF0. IN1A		ERU1. 2B0	CCU40. IN1A			
P1.3	ECAT0. P0_TX_ENA	U0C0. MCLKOUT	CCU40. OUT0	ERU1. PDOUT0	U0C0. DOUT2	EBU. AD15	U0C0. HWIN2	EBU. D15		POSIF0. IN0A		ERU1. 2A0	CCU40. IN0A			
P1.4	WWDT. SERVICE_OUT	CAN. NO_TXD	CCU80. OUT33	CCU81. OUT20	U0C0. DOUT1		U0C0. HWIN1		U0C0. DX0B	CAN. N1_RXDD	ERU0. 2B0		CCU41. IN0C		ECAT0. P0_RXD0A	

Table 12 Port I/O Functions (cont'd)

Function	Outputs						Inputs								
	ALT1	ALT2	ALT3	ALT4	HWO0	HWO1	HWO0	HWO1	Input	Input	Input	Input	Input	Input	Input
P1.5	CAN_N1_TXD	U0C0_DOUT0	CCU80_OUT23	CCU81_OUT10	U0C0_DOUT0		U0C0_HWI0	U0C0_DX0A	ERU0_ZA0	ERU1_0A0	CCU41_IN1C	DSD_DIN2B		ECAT0_PO_RXD1A	
P1.6	ECAT0_PO_TXD0	U0C0_SCLKOUT			SDMMC_DATA1_OUT	EBU_AD10	SDMMC_DATA1_IN	EBU_D10	DSD_DIN2A						
P1.7	ECAT0_PO_TXD1	U0C0_DOUT0	DSD_MCLK2	U1C1_SELO2	SDMMC_DATA2_OUT	EBU_AD11	SDMMC_DATA2_IN	EBU_D11	DSD_MCLK2A		DSD_MCLK3C				
P1.8	ECAT0_PO_TXD2	U0C0_SELO1	DSD_MCLK1	U1C1_SCLKOUT	SDMMC_DATA4_OUT	EBU_AD12	SDMMC_DATA4_IN	EBU_D12	CAN_N2_RXDA	DSD_MCLK1A	DSD_MCLK0D	DSD_MCLK2D	DSD_MCLK3D		
P1.9	U0C0_SCLKOUT	CAN_N2_TXD	DSD_MCLK0	U1C1_DOUT0	SDMMC_DATA5_OUT	EBU_AD13	SDMMC_DATA5_IN	EBU_D13	DSD_MCLK0A		DSD_MCLK1C	DSD_MCLK2C	DSD_MCLK3C	ECAT0_PO_RX_DVA	
P1.10	ETH0_MDC	U0C0_SCLKOUT	CCU81_OUT21	ECAT0_LED_ERR			SDMMC_SDCD				CCU41_IN2C			ECAT0_PO_RXD2A	
P1.11	ECAT0_LED_STATE_RUN	U0C0_SELO0	CCU81_OUT11	ECAT0_LED_RUN	ETH0_MDO		ETH0_MDIC				CCU41_IN3C			ECAT0_PO_RXD3A	
P1.12	ETH0_TX_EN	CAN_N1_TXD	CCU81_OUT01	ECAT0_PO_LINK_ACT	SDMMC_DATA6_OUT	EBU_AD16	SDMMC_DATA6_IN	EBU_D16							
P1.13	ETH0_TXD0	U0C1_SELO3	CCU81_OUT20	ECAT0_PHY_CLK25	SDMMC_DATA7_OUT	EBU_AD17	SDMMC_DATA7_IN	EBU_D17	CAN_N1_RXDC						
P1.14	ETH0_TXD1	U0C1_SELO2	CCU81_OUT10	ECAT0_SYNC0		EBU_AD18		EBU_D18	U1C0_DX0E						
P1.15	SCU_EXTCLK	DSD_MCLK2	CCU81_OUT00	U1C0_DOUT0		EBU_AD19		EBU_D19	DSD_MCLK2B		ERU1_1A0			ECAT0_PO_LINKB	
P2.0	CAN_NO_TXD	CCU81_OUT21	DSD_GCPWMN	LEDTS0_COL1	ETH0_MDO	EBU_AD20	ETH0_MDB	EBU_D20		ERU0_0B3		CCU40_IN1C			
P2.1	CAN_NS_TXD	CCU81_OUT11	DSD_GCPWMP	LEDTS0_COL0	DB_TDO/TRACESVO	EBU_AD21		EBU_D21	ETH0_CLK_RMIIA		ERU1_0B0	CCU40_IN0C		ETH0_CLKRXA	
P2.2	VADC_EMUX00	CCU41_OUT01	CCU41_OUT3	LEDTS0_LINE0	LEDTS0_EXTENDED0	EBU_AD22	LEDTS0_TSINGA	EBU_D22	ETH0_RXD0A	U0C1_DX0A	ERU0_1B2		CCU41_IN3A		
P2.3	VADC_EMUX01	U0C1_SELO0	CCU41_OUT2	LEDTS0_LINE1	LEDTS0_EXTENDED1	EBU_AD23	LEDTS0_TSINGA	EBU_D23	ETH0_RXD1A	U0C1_DX2A	ERU0_1A2	POSIF1_IN2A	CCU41_IN2A		
P2.4	VADC_EMUX02	U0C1_SCLKOUT	CCU41_OUT1	LEDTS0_LINE2	LEDTS0_EXTENDED2	EBU_AD24	LEDTS0_TSINGA	EBU_D24	ETH0_RXERA	U0C1_DX1A	ERU0_0B2	POSIF1_IN1A	CCU41_IN1A		
P2.5	ETH0_TX_EN	U0C1_DOUT0	CCU41_OUT0	LEDTS0_LINE3	LEDTS0_EXTENDED3	EBU_AD25	LEDTS0_TSINGA	EBU_D25	ETH0_RXDVA	U0C1_DX0B	ERU0_0A2	POSIF1_IN0A	CCU41_IN0A	ETH0_CRS_DVA	
P2.6	U0C0_SELO4	ERU1_PDOU73	CCU80_OUT13	LEDTS0_COL3	U2C0_DOUT3		U2C0_HWI3	U2C0_DX0A	CAN_N1_RXDA	ERU0_1B3	CAN_NS_RXDB	CCU40_IN3C	ECAT0_PO_RX_ERRB		
P2.7	ETH0_MDC	CAN_N1_TXD	CCU80_OUT03	LEDTS0_COL2					DSD_DIN0B		ERU1_1B0	CCU40_IN2C			
P2.8	ETH0_TXD0	ERU1_PDOU71	CCU80_OUT32	LEDTS0_LINE4	LEDTS0_EXTENDED4	EBU_AD26	LEDTS0_TSINGA	EBU_D26	DAC_TRIGGERS			CCU40_IN0B	CCU40_IN2B	CCU40_IN3B	
P2.9	ETH0_TXD1	ERU1_PDOU72	CCU80_OUT22	LEDTS0_LINE5	LEDTS0_EXTENDED5	EBU_AD27	LEDTS0_TSINGA	EBU_D27	DAC_TRIGGER4			CCU41_IN0B	CCU41_IN1B	CCU41_IN2B	CCU41_IN3B
P2.10	VADC_EMUX10	ERU1_PDOU70	ECAT0_PHY_RST	ECAT0_SYNC1	DB_ETM_TRACEDA1A3	EBU_AD28		EBU_D28							
P2.11	ETH0_TXER	ECAT0_P1_TXD0	CCU80_OUT22		DB_ETM_TRACEDA1A2	EBU_AD29		EBU_D29							

Table 12 Port I/O Functions (cont'd)

Function	Outputs						Inputs									
	ALT1	ALT2	ALT3	ALT4	HWO0	HWO1	HWI0	HWI1	Input	Input	Input	Input	Input	Input	Input	Input
P2.12	ETH0_TXD2	ECAT0_P1_TXD1	CCU81_OUT33	ETH0_TXD0	DB_ETM_TRACEDA_TA1	EBU_AD30		EBU_D30					CCU43_IN3C			
P2.13	ETH0_TXD3	ECAT0_P1_TXD2		ETH0_TXD1	DB_ETM_TRACEDA_TA0	EBU_AD31		EBU_D31					CCU43_IN2C			
P2.14	VADC_EMUX11	U1C0_DOUT0	CCU80_OUT21	CAN_N4_TXD	DB_ETM_TRACECLK	EBU_BC0				U1C0_DX0D			CCU43_IN0B	CCU43_IN1B	CCU43_IN2B	CCU43_IN3B
P2.15	VADC_EMUX12	ECAT0_P1_TXD3	CCU80_OUT11	LEDT50_LINE6	LEDT50_EXTENDED6	EBU_BCT	LEDT50_TSIN6A		ETH0_COLA	U1C0_DX0C	CAN_N4_RXDA		CCU42_IN0B	CCU42_IN1B	CCU42_IN2B	CCU42_IN3B
P3.0	U2C1_SEL00	U0C1_SCLKOUT	CCU42_OUT0	ECAT0_P1_TX_ENA		EBU_RD			U0C1_DX1B				CCU80_IN2C	CCU81_IN0C		
P3.1		U0C1_SEL00	ECAT0_P1_TXD0			EBU_RD_WR			U0C1_DX2B		ERU0_0B1		CCU80_IN1C			
P3.2	USB_DRIVEVBUS	CAN_NO_TXD	ECAT0_P1_TXD1	LEDT50_COLA		EBU_CS0					ERU0_0A1		CCU80_IN0C			
P3.3		U1C1_SEL01	CCU42_OUT3	ECAT0_MCLK	SDMMC_LED			EBU_WAIT		DSD_DIN3B			CCU42_IN3A	CCU80_IN3B		
P3.4	U0C1_SCLKOUT	U1C1_SEL02	CCU42_OUT2	DSD_MCLK3	SDMMC_BUS_POWER			EBU_HOLD	U2C1_DX0B	DSD_MCLK3B			CCU42_IN2A	CCU80_IN0B	ECAT0_P1_LINKA	
P3.5	U2C1_DOUT0	U1C1_SEL03	CCU42_OUT1	U0C1_DOUT0	SDMMC_CMD_OUT	EBU_AD4	SDMMC_CMD_IN	EBU_D4	U2C1_DX0A		ERU0_3B1		CCU42_IN1A		ECAT0_P1_RX_ERRA	
P3.6	U2C1_SCLKOUT	U1C1_SEL04	CCU42_OUT0	U0C1_SCLKOUT	SDMMC_CLK_OUT	EBU_AD5	SDMMC_CLK_IN	EBU_D5	U2C1_DX1B		ERU0_3A1		CCU42_IN0A			
P3.7	ECAT0_SYNC0	CAN_N2_TXD	CCU41_OUT3	LEDT50_LINE0					U2C0_DX0C							
P3.8	U2C0_DOUT0	U0C1_SEL03	CCU41_OUT2	LEDT50_LINE1							CAN_N2_RXDB			POSIF1_IN2B		
P3.9	U2C0_SCLKOUT	CAN_N1_TXD	CCU41_OUT1	LEDT50_LINE2										POSIF1_IN1B		
P3.10	U2C0_SEL00	CAN_NO_TXD	CCU41_OUT0	LEDT50_LINE3	U0C1_DOUT3			U0C1_HWIN3						POSIF1_IN0B		
P3.11	U2C1_DOUT0	U0C1_SEL02	CCU42_OUT3	LEDT50_LINE4	U0C1_DOUT2			U0C1_HWIN2		CAN_N1_RXDB				CCU81_IN3C		
P3.12	ECAT0_P1_LINK_ACT	U0C1_SEL01	CCU42_OUT2	LEDT50_LINE5	U0C1_DOUT1			U0C1_HWIN1	CAN_NO_RXDC	U2C1_DX0D				CCU81_IN2C		
P3.13	U2C1_SCLKOUT	U0C1_DOUT0	CCU42_OUT1	LEDT50_LINE6	U0C1_DOUT0			U0C1_HWIN0	U0C1_DX0D				CCU80_IN3C	CCU81_IN1C		
P3.14		U1C0_SEL03			U1C1_DOUT1			U1C1_HWIN1		U1C1_DX0B			CCU42_IN1C			
P3.15		U1C1_DOUT0			U1C1_DOUT0			U1C1_HWIN0		U1C1_DX0A			CCU42_IN0C			
P4.0	CAN_N3_TXD	ECAT0_PHY_CLK25	DSD_MCLK1	U1C0_SCLKOUT	SDMMC_DATA0_OUT	EBU_AD6	SDMMC_DATA0_IN	EBU_D6	U1C1_DX1C	DSD_MCLK1B	U0C1_DX0E	U2C1_DX0C				ECAT0_P0_RX_ERRA
P4.1	U2C1_SEL00	U1C1_MCLKOUT	DSD_MCLK0	U0C1_SEL00	SDMMC_DATA3_OUT	EBU_AD9	SDMMC_DATA3_IN	EBU_D9	U2C1_DX2B	DSD_MCLK0B		U2C1_DX2A	DSD_MCLK1D			ECAT0_P0_LINKA
P4.2	U2C1_SEL01	U1C1_DOUT0		ECAT0_MDO	ECAT0_MDO		ECAT0_MDOB		U1C1_DX0C			U2C1_DX1A	CCU43_IN1C			

Table 12 Port I/O Functions (cont'd)

Function	Outputs						Inputs										
	ALT1	ALT2	ALT3	ALT4	HWO0	HWO1	HWI0	HWI1	Input	Input	Input	Input	Input	Input	Input		
P4.3	U0C1. SELO2	U0C0. SELOS	CCU43. OUT3	ECAT0. MCLK									CCU43. IN3A				
P4.4		U0C0. SELO4	CCU43. OUT2		U2C1. DOUT3								CCU43. IN2A				
P4.5		U0C0. SELO3	CCU43. OUT1		U2C1. DOUT2								CCU43. IN1A				
P4.6		U0C0. SELO2	CCU43. OUT0		U2C1. DOUT1					CAN. N2_RXDC		U2C1. DX0E	CCU43. IN0A				
P4.7	U2C1. DOUT0	CAN. N2_TXD			U2C1. DOUT0					U2C1. HWIN0			CCU43. IN0C				
P5.0	U2C0. DOUT0	DSD. CGPWMM	CCU81. PDOUT3	ERU1. PDOUT0	U2C0. DOUT0					U2C0. HWIN0	U2C0. DX0B	ETH0. RXD0D	U0C0. DX0D	ECAT0. PO_RXD0B	CCU81. IN0A	CCU81. IN2A	CCU81. IN3A
P5.1	U0C0. DOUT0	DSD. CGPWMP	CCU81. PDOUT32	ERU1. PDOUT1	U2C0. DOUT1					U2C0. HWIN1	U2C0. DX0A	ETH0. RXD1D		ECAT0. PO_RXD1B	CCU81. IN0B		
P5.2	U2C0. SCLKOUT	ECAT0. PO_LINK_ACT	CCU81. OUT23	ERU1. PDOUT2							U2C0. DX1A	ETH0. CRS_DVD		ECAT0. PO_RXD2B	CCU81. IN1B		ETH0. RXDVD
P5.3	U2C0. SELO0		CCU81. OUT22	ERU1. PDOUT3	EBU. CKE	EBU. A20						ETH0. RXERD			CCU81. IN2B		
P5.4	U2C0. SELO1		CCU81. OUT13		EBU. RAS	EBU. A21						ETH0. CRSD			CCU81. IN3B		ECAT0. PO_RX_CLKB
P5.5	U2C0. SELO2		CCU81. OUT12		EBU. CAS	EBU. A22						ETH0. COLD					ECAT0. PO_TX_CLKB
P5.6	U2C0. SELO3		CCU81. OUT03		EBU. BFCLK0	EBU. A23					EBU. BFCLKI						ECAT0. PO_RX_DVB
P5.7	ECAT0. SYNC0		CCU81. OUT92	LEDS0. COLA	U2C0. DOUT2									ECAT0. PO_RXD3B			
P5.8	ECAT0. P1_TX_ENA	U1C0. SCLKOUT	CCU80. OUT01	CAN. N4_TXD	EBU. SDCLK0	EBU. CS2						ETH0. RXD2A	U1C0. DX1B				
P5.9		U1C0. SELO0	CCU80. OUT20	ETH0. TX_EN	EBU. BFCLK0	EBU. CS3						ETH0. RXD3A	U1C0. DX2B			ECAT0. P1_TX_CLKB	
P5.10		U1C0. MCLKOUT	CCU80. OUT10	LEDS0. LINE7	LEDS0. EXTENDED7							ETH0. CLK_TXA		CAN. N5_RXDA			
P5.11		U1C0. SELO1	CCU80. OUT00	CAN. N5_TXD								ETH0. CRSA					
P6.0	ETH0. TXD2	U0C1. SELO1	CCU81. OUT31	ECAT0. PHY_CLK25	DB. ETM_TRACECLK	EBU. A16											
P6.1	ETH0. TXD3	U0C1. SELO0	CCU81. OUT30	ECAT0. PO_TX_ENA	DB. ETM_TRACEDA TA3	EBU. A17						U0C1. DX2C					
P6.2	ETH0. TXER	U0C1. SCLKOUT	CCU43. OUT3	ECAT0. PO_TXD0	DB. ETM_TRACEDA TA2	EBU. A18						U0C1. DX1C					
P6.3			CCU43. OUT2	ECAT0. PO_LINK_ACT								U0C1. DX0C	ETH0. RXD3B				
P6.4		U0C1. DOUT0	CCU43. OUT1	ECAT0. PO_TXD1	EBU. SDCLK0	EBU. A19						EBU. SDCLKI	ETH0. RXD2B				
P6.5	CAN. N3_TXD	U0C1. MCLKOUT	CCU43. OUT0	ECAT0. PO_TXD2	DB. ETM_TRACEDA TA1	EBU. BC2						DSD. DIN3A	ETH0. CLK_RMIIID				ETH0. CLKRXD

Table 12 Port I/O Functions (cont'd)

Function	Outputs						Inputs									
	ALT1	ALT2	ALT3	ALT4	HWO0	HWO1	HWI0	HWI1	Input	Input	Input	Input	Input	Input	Input	Input
P6.6	U0C0. DOUT0		DSD. MCLK3	ECAT0. P0_TXD3	DB. ETM_TRACEDA TA0	EBU. BC3			DSD. MCLK3A	ETH0. CLK_TXB		CAN. NS_RXDB				
P7.0		CAN. NS_TXD		ECAT0. P0_TXD0	EBU. A19											
P7.1				ECAT0. P0_TXD1	EBU. A20					CAN. NS_RXDC						
P7.2		CAN. N4_TXD		ECAT0. P0_TXD2	EBU. A21											
P7.3				ECAT0. P0_TXD3	EBU. A22					CAN. N4_RXDC						
P7.4			CCU42. OUT0						ECAT0. P0_RXD0C							
P7.5			CCU42. OUT1						ECAT0. P0_RXD1C							
P7.6			CCU42. OUT2						ECAT0. P0_RXD2C							
P7.7			CCU42. OUT3						ECAT0. P0_RXD3C							
P7.8		CAN. NS_TXD		ECAT0. P0_TX_ENA	DB. ETM_TRACECLK											
P7.9			CCU80. OUT22						ECAT0. P0_RX_ERRRC							
P7.10			CCU80. OUT32						ECAT0. P0_RX_CLKC							
P7.11			CCU80. OUT33						ECAT0. P0_RX_DVC							
P8.0				ECAT0. P1_TXD0	DB. ETM_TRACEDA TA0					CAN. NS_RXDC						
P8.1				ECAT0. P1_TXD1	DB. ETM_TRACEDA TA1					U0C0. DX2C						
P8.2				ECAT0. P1_TXD2	DB. ETM_TRACEDA TA2											
P8.3				ECAT0. P1_TXD3	DB. ETM_TRACEDA TA3					U0C0. DX1C						
P8.4		U0C0. SELO1							ECAT0. P1_RXD0C							
P8.5		U0C0. SCLKOUT							ECAT0. P1_RXD1C							
P8.6		U0C0. SELO0							ECAT0. P1_RXD2C							
P8.7		U0C0. DOUT0							ECAT0. P1_RXD3C							
P8.8				ECAT0. P1_TX_ENA						U0C0. DX0E						

Table 12 Port I/O Functions (cont'd)

Function	Outputs						Inputs								
	ALT1	ALT2	ALT3	ALT4	HWO0	HWO1	HWI0	HWI1	Input	Input	Input	Input	Input	Input	Input
P8.9			CCU81. OUT33						ECAT0. P1_RX_ERRRC						
P8.10			CCU81. OUT21						ECAT0. P1_RX_CLKC						
P8.11			CCU81. OUT11						ECAT0. P1_RX_DVC						
P9.0		U2C0. SELO0		ECAT0. SYNC0					ECAT0. LATCH0B	U2C0. DX2C		ECAT0. P1_TX_CLKC			
P9.1		U2C0. SCLKOUT		ECAT0. SYNC1					ECAT0. LATCH1B	U2C0. DX1C		ECAT0. P0_TX_CLKC			
P9.2		U2C0. SELO1		ECAT0. PHY_RST					ETH0. COLC						
P9.3		U2C0. DOUT0		ECAT0. PHY_CLK25					ETH0. CRSC						
P9.4	ECAT0. LED_STATE_RU N			ECAT0. LED_RUN						U2C0. DX0E					
P9.5		U2C0. SELO2		ECAT0. LED_ERR					ETH0. RXDXC						
P9.6		U2C0. SELO3		ECAT0. MCLK					ETH0. RXDXC						
P9.7		U2C0. SELO4			ECAT0. MDO		ECAT0. MDIC		ETH0. RXERC						
P9.8				ECAT0. P0_LINK_ACT						U2C1. DX2C					
P9.9				ECAT0. P1_LINK_ACT						U2C1. DX1C					
P9.10		U2C1. DOUT0							ECAT0. P0_LINKC						
P9.11		U2C1. SELO3							ECAT0. P1_LINKC						
P14.0									VADC. GOCH0						
P14.1									VADC. GOCH1						
P14.2									VADC. GOCH2	VADC. G1CH2					
P14.3									VADC. GOCH3	VADC. G1CH3			CAN. NO_RXDB		
P14.4									VADC. GOCH4		VADC. G2CH0			CAN. N4_RXDB	ECAT0. LATCH1A
P14.5									VADC. GOCH5		VADC. G2CH1		POSIFO. IN2B		ECAT0. LATCH0A
P14.6									VADC. GOCH6				POSIFO. IN1B	GOORC6	ECAT0. P1_RX_CLKB
P14.7									VADC. GOCH7				POSIFO. IN0B	GOORC7	ECAT0. P1_RXDBB

Table 12 Port I/O Functions (cont'd)

Function	Outputs						Inputs									
	ALT1	ALT2	ALT3	ALT4	HWO0	HWO1	HWI0	HWI1	Input	Input	Input	Input	Input	Input	Input	Input
P14.8					DAC. OUT_0					VADC. G1CH0		VADC. G3CH2	ETH0. RXDOC			
P14.9					DAC. OUT_1					VADC. G1CH1		VADC. G3CH3	ETH0. RXD1C			
P14.12										VADC. G1CH4						ECAT0. P1_RXD1B
P14.13										VADC. G1CH5						ECAT0. P1_RXD2B
P14.14										VADC. G1CH6				G1ORC6		ECAT0. P1_RXD3B
P14.15										VADC. G1CH7				G1ORC7		ECAT0. P1_RX_DVB
P15.2											VADC. G2CH2					ECAT0. P1_RX_ERRB
P15.3											VADC. G2CH3					ECAT0. P1_LINKB
P15.4											VADC. G2CH4					
P15.5											VADC. G2CH5					
P15.6											VADC. G2CH6					
P15.7											VADC. G2CH7					
P15.8												VADC. G3CH9	ETH0. CLK_RMIIIC			ETH0. CLKRXIC
P15.9												VADC. G3CH1	ETH0. CRS_DVC			ETH0. RXDVC
P15.12												VADC. G3CH4				
P15.13												VADC. G3CH5				
P15.14												VADC. G3CH6				
P15.15												VADC. G3CH7				
HIB_JO_0	HIBOUT	WVDT. SERVICE_OUT							WAKEUPA							
HIB_JO_1	HIBOUT	WVDT. SERVICE_OUT							WAKEUPB							
USB_DP																
USB_DM																
TCK								DB.TCK/ SWCLK								
TMS					DB.TMS/ SWDIO											
PORST																

Table 12 Port I/O Functions (cont'd)

Function	Outputs						Inputs									
	ALT1	ALT2	ALT3	ALT4	HWO0	HWO1	HWI0	HWI1	Input	Input	Input	Input	Input	Input	Input	Input
XTAL1									USC0. DX0F	USC1. DX0F	U1C0. DX0F	U1C1. DX0F	USC0. DX0F	USC1. DX0F		
XTAL2																
RTC_XTAL1											ERU0. 1B1					
RTC_XTAL2																

2.3 Power Connection Scheme

Figure 9. shows a reference power connection scheme for the XMC4[78]00.

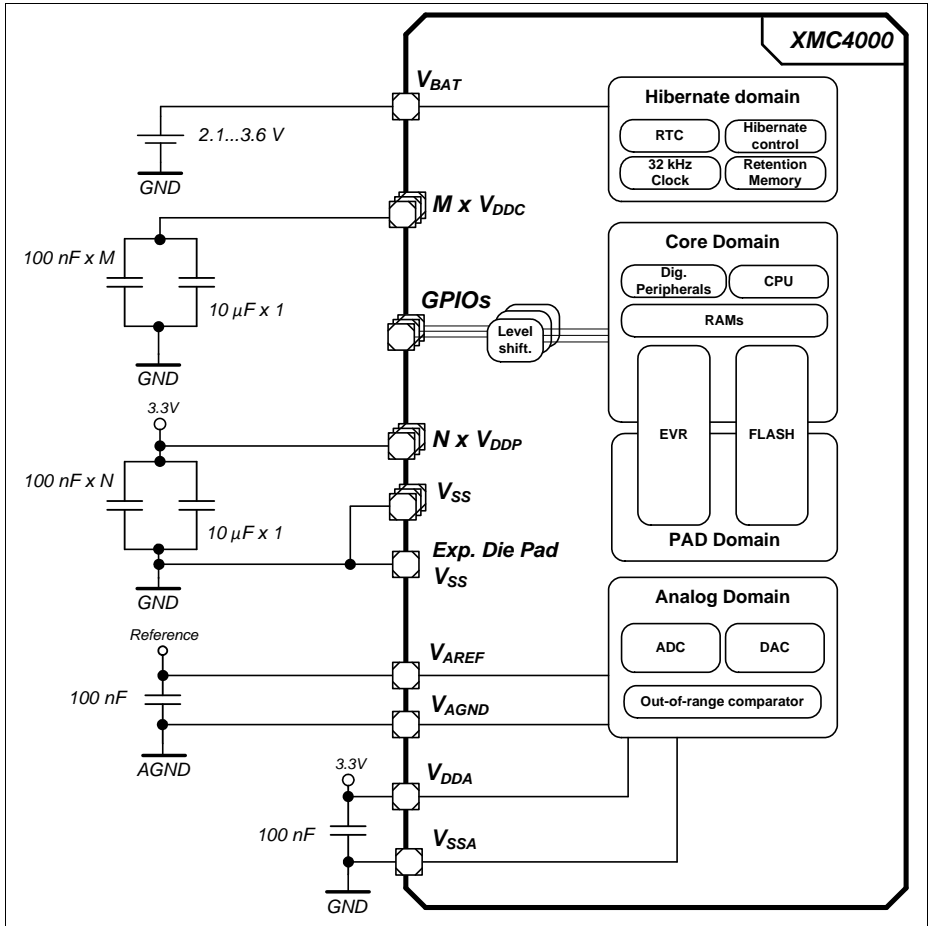

Figure 9 Power Connection Scheme

Every power supply pin needs to be connected. Different pins of the same supply need also to be externally connected. As example, all V_{DDP} pins must be connected externally to one V_{DDP} net. In this reference scheme one 100 nF capacitor is connected at each supply pin against V_{SS} . An additional 10 μ F capacitor is connected to the V_{DDP} nets and an additional 10 μ F capacitor to the V_{DDC} nets.

The XMC4[78]00 has a common ground concept, all V_{SS} , V_{SSA} and V_{SSO} pins share the same ground potential. In packages with an exposed die pad it must be connected to the common ground as well.

V_{AGND} is the low potential to the analog reference V_{AREF} . Depending on the application it can share the common ground or have a different potential. In devices with shared V_{DDA}/V_{AREF} and V_{SSA}/V_{AGND} pins the reference is tied to the supply. Some analog channels can optionally serve as “Alternate Reference”; further details on this operating mode are described in the Reference Manual.

When V_{DDP} is supplied, V_{BAT} must be supplied as well. If no other supply source (e.g. battery) is connected to V_{BAT} , the V_{BAT} pin can also be connected directly to V_{DDP} .

3 Electrical Parameters

Attention: All parameters in this chapter are preliminary target values and may change based on characterization results.

3.1 General Parameters

3.1.1 Parameter Interpretation

The parameters listed in this section partly represent the characteristics of the XMC4[78]00 and partly its requirements on the system. To aid interpreting the parameters easily when evaluating them for a design, they are marked with a two-letter abbreviation in column "Symbol":

- **CC**
Such parameters indicate **C**ontroller **C**haracteristics, which are a distinctive feature of the XMC4[78]00 and must be regarded for system design.
- **SR**
Such parameters indicate **S**ystem **R**equirements, which must be provided by the application system in which the XMC4[78]00 is designed in.

3.1.2 Absolute Maximum Ratings

Stresses above the values listed under “Absolute Maximum Ratings” may cause permanent damage to the device. This is a stress rating only and functional operation of the device at these or any other conditions above those indicated in the operational sections of this specification is not implied. Exposure to absolute maximum rating conditions may affect device reliability.

Table 13 Absolute Maximum Rating Parameters

Parameter	Symbol		Values			Unit	Note / Test Condition
			Min.	Typ.	Max.		
Storage temperature	T_{ST}	SR	-65	–	150	°C	–
Junction temperature	T_J	SR	-40	–	150	°C	–
Voltage at 3.3 V power supply pins with respect to V_{SS}	V_{DDP}	SR	–	–	4.3	V	–
Voltage on any Class A and dedicated input pin with respect to V_{SS}	V_{IN}	SR	-1.0	–	$V_{DDP} + 1.0$ or max. 4.3	V	whichever is lower
Voltage on any analog input pin with respect to V_{AGND}	V_{AIN} V_{AREF}	SR	-1.0	–	$V_{DDP} + 1.0$ or max. 4.3	V	whichever is lower
Input current on any pin during overload condition	I_{IN}	SR	-10	–	+10	mA	
Absolute maximum sum of all input circuit currents for one port group during overload condition ¹⁾	ΣI_{IN}	SR	-25	–	+25	mA	
Absolute maximum sum of all input circuit currents during overload condition	ΣI_{IN}	SR	-100	–	+100	mA	

1) The port groups are defined in [Table 17](#).

Figure 10 explains the input voltage ranges of V_{IN} and V_{AIN} and its dependency to the supply level of V_{DDP} . The input voltage must not exceed 4.3 V, and it must not be more than 1.0 V above V_{DDP} . For the range up to $V_{DDP} + 1.0$ V also see the definition of the overload conditions in [Section 3.1.3](#).

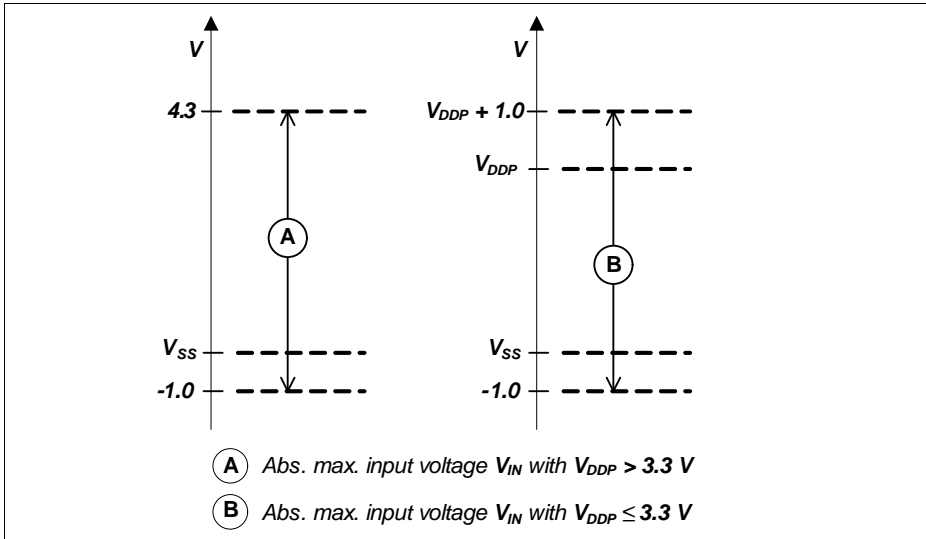

Figure 10 Absolute Maximum Input Voltage Ranges

3.1.3 Pin Reliability in Overload

When receiving signals from higher voltage devices, low-voltage devices experience overload currents and voltages that go beyond their own IO power supplies specification.

Table 14 defines overload conditions that will not cause any negative reliability impact if all the following conditions are met:

- full operation life-time is not exceeded
- **Operating Conditions** are met for
 - pad supply levels (V_{DDP} or V_{DDA})
 - temperature

If a pin current is outside of the **Operating Conditions** but within the overload conditions, then the parameters of this pin as stated in the Operating Conditions can no longer be guaranteed. Operation is still possible in most cases but with relaxed parameters.

Note: An overload condition on one or more pins does not require a reset.

Note: A series resistor at the pin to limit the current to the maximum permitted overload current is sufficient to handle failure situations like short to battery.

Table 14 Overload Parameters

Parameter	Symbol		Values			Unit	Note / Test Condition
			Min.	Typ.	Max.		
Input current on any port pin during overload condition	I_{OV}	SR	-5	–	5	mA	
Absolute sum of all input circuit currents for one port group during overload condition ¹⁾	I_{OVG}	SR	–	–	20	mA	$\Sigma I_{OVx} $, for all $I_{OVx} < 0$ mA
			–	–	20	mA	$\Sigma I_{OVx} $, for all $I_{OVx} > 0$ mA
Absolute sum of all input circuit currents during overload condition	I_{OVS}	SR	–	–	80	mA	ΣI_{OVG}

1) The port groups are defined in [Table 17](#).

Figure 11 shows the path of the input currents during overload via the ESD protection structures. The diodes against V_{DDP} and ground are a simplified representation of these ESD protection structures.

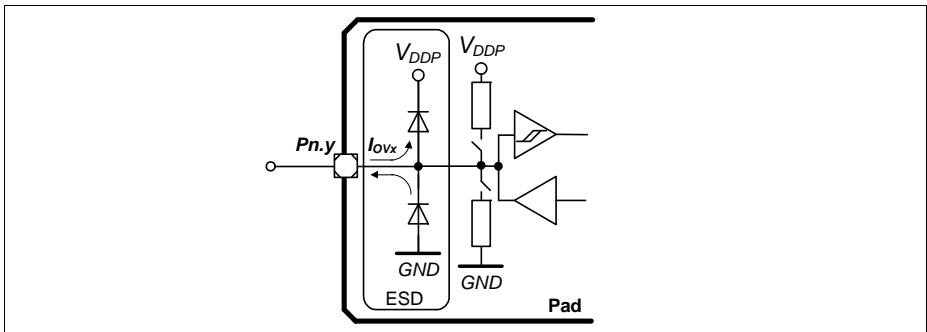

Figure 11 Input Overload Current via ESD structures

Table 15 and **Table 16** list input voltages that can be reached under overload conditions. Note that the absolute maximum input voltages as defined in the **Absolute Maximum Ratings** must not be exceeded during overload.

Table 15 PN-Junction Characteristics for positive Overload

Pad Type	$I_{OV} = 5 \text{ mA}, T_J = -40 \text{ }^\circ\text{C}$	$I_{OV} = 5 \text{ mA}, T_J = 150 \text{ }^\circ\text{C}$
A1 / A1+	$V_{IN} = V_{DDP} + 1.0 \text{ V}$	$V_{IN} = V_{DDP} + 0.75 \text{ V}$
A2	$V_{IN} = V_{DDP} + 0.7 \text{ V}$	$V_{IN} = V_{DDP} + 0.6 \text{ V}$
AN/DIG_IN	$V_{IN} = V_{DDP} + 1.0 \text{ V}$	$V_{IN} = V_{DDP} + 0.75 \text{ V}$

Table 16 PN-Junction Characteristics for negative Overload

Pad Type	$I_{OV} = 5 \text{ mA}, T_J = -40 \text{ }^\circ\text{C}$	$I_{OV} = 5 \text{ mA}, T_J = 150 \text{ }^\circ\text{C}$
A1 / A1+	$V_{IN} = V_{SS} - 1.0 \text{ V}$	$V_{IN} = V_{SS} - 0.75 \text{ V}$
A2	$V_{IN} = V_{SS} - 0.7 \text{ V}$	$V_{IN} = V_{SS} - 0.6 \text{ V}$
AN/DIG_IN	$V_{IN} = V_{DDP} - 1.0 \text{ V}$	$V_{IN} = V_{DDP} - 0.75 \text{ V}$

Table 17 Port Groups for Overload and Short-Circuit Current Sum Parameters

Group	Pins
1	P0.[15:0], P3.[15:0], P8.[11:0]
2	P14.[15:0], P15.[15:0]
3	P2.[15:0], P5.[11:0], P7[11:0]
4	P1.[15:0], P4.[7:0], P6.[6:0], P9.[11:0]

3.1.4 Pad Driver and Pad Classes Summary

This section gives an overview on the different pad driver classes and their basic characteristics.

Table 18 Pad Driver and Pad Classes Overview

Class	Power Supply	Type	Sub-Class	Speed Grade	Load	Termination
A	3.3 V	LVTTTL I/O	A1 (e.g. GPIO)	6 MHz	100 pF	No
			A1+ (e.g. serial I/Os)	25 MHz	50 pF	Series termination recommended
			A2 (e.g. ext. Bus)	80 MHz	15 pF	Series termination recommended

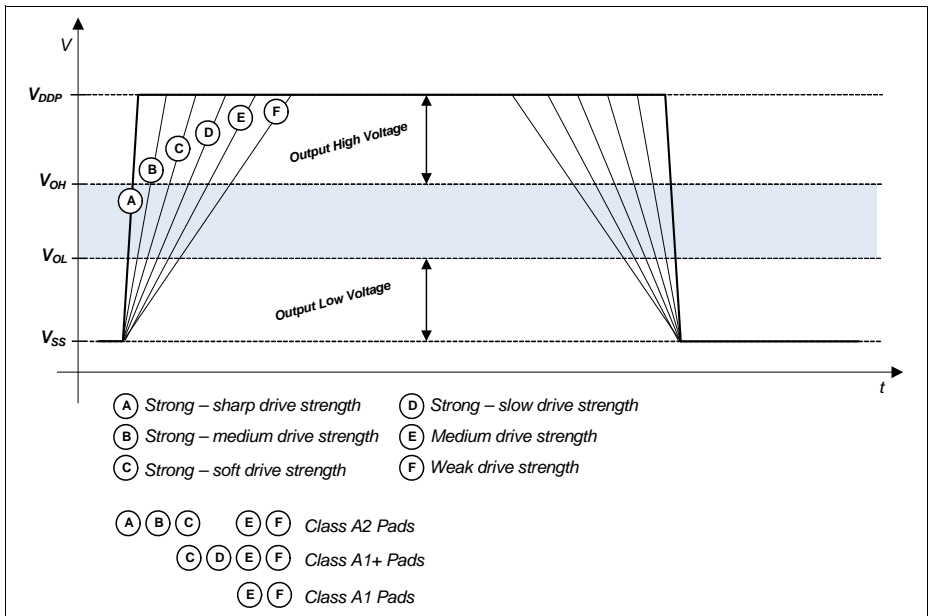

Figure 12 Output Slopes with different Pad Driver Modes

Figure 12 is a qualitative display of the resulting output slope performance with different output driver modes. The detailed input and output characteristics are listed in **Section 3.2.1**.

3.1.5 Operating Conditions

The following operating conditions must not be exceeded in order to ensure correct operation and reliability of the XMC4[78]00. All parameters specified in the following sections refer to these operating conditions, unless noted otherwise.

Table 19 Operating Conditions Parameters

Parameter	Symbol	Values			Unit	Note / Test Condition
		Min.	Typ.	Max.		
Ambient Temperature	T_A SR	-40	–	85	°C	Temp. Range F
		-40	–	125	°C	Temp. Range K
Digital supply voltage	V_{DDP} SR	3.13 ¹⁾	3.3	3.63 ²⁾	V	
Core Supply Voltage	V_{DDC} CC	– ¹⁾	1.3	–	V	Generated internally
Digital ground voltage	V_{SS} SR	0	–	–	V	
ADC analog supply voltage	V_{DDA} SR	3.0	3.3	3.6 ²⁾	V	
Analog ground voltage for V_{DDA}	V_{SSA} SR	-0.1	0	0.1	V	
Battery Supply Voltage for Hibernate Domain	V_{BAT} SR	1.95 ³⁾	–	3.63	V	When V_{DDP} is supplied V_{BAT} has to be supplied as well.
System Frequency	f_{SYS} SR	–	–	144	MHz	
Short circuit current of digital outputs	I_{SC} SR	-5	–	5	mA	
Absolute sum of short circuit currents per pin group ⁴⁾	ΣI_{SC_PG} SR	–	–	20	mA	
Absolute sum of short circuit currents of the device	ΣI_{SC_D} SR	–	–	100	mA	

1) See also the Supply Monitoring thresholds, [Section 3.3.2](#).

2) Voltage overshoot to 4.0 V is permissible at Power-Up and \overline{PORST} low, provided the pulse duration is less than 100 μ s and the cumulated sum of the pulses does not exceed 1 h over lifetime.

3) To start the hibernate domain it is required that $V_{BAT} \geq 2.1$ V, for a reliable start of the oscillation of RTC_XTAL in crystal mode it is required that $V_{BAT} \geq 3.0$ V.

4) The port groups are defined in [Table 17](#).

3.2 DC Parameters

3.2.1 Input/Output Pins

The digital input stage of the shared analog/digital input pins is identical to the input stage of the standard digital input/output pins.

The Pull-up on the PORST pin is identical to the Pull-up on the standard digital input/output pins.

Note: These parameters are not subject to production test, but verified by design and/or characterization.

Table 20 Standard Pad Parameters

Parameter	Symbol	Values		Unit	Note / Test Condition
		Min.	Max.		
Pin capacitance (digital inputs/outputs)	C_{IO} CC	–	10	pF	
Pull-down current	$ I_{PDL} $ SR	150	–	μA	¹⁾ $V_{IN} \geq 0.6 \times V_{DDP}$
		–	10	μA	²⁾ $V_{IN} \leq 0.36 \times V_{DDP}$
Pull-Up current	$ I_{PUH} $ SR	–	10	μA	²⁾ $V_{IN} \geq 0.6 \times V_{DDP}$
		100	–	μA	¹⁾ $V_{IN} \leq 0.36 \times V_{DDP}$
Input Hysteresis for pads of all A classes ³⁾	HYS_A CC	$0.1 \times V_{DDP}$	–	V	
PORST spike filter always blocked pulse duration	t_{SF1} CC	–	10	ns	
PORST spike filter pass-through pulse duration	t_{SF2} CC	100	–	ns	
PORST pull-down current	$ I_{PPD} $ CC	13	–	mA	$V_{IN} = 1.0 \text{ V}$

1) Current required to override the pull device with the opposite logic level (“force current”).

With active pull device, at load currents between force and keep current the input state is undefined.

2) Load current at which the pull device still maintains the valid logic level (“keep current”).

With active pull device, at load currents between force and keep current the input state is undefined.

3) Hysteresis is implemented to avoid metastable states and switching due to internal ground bounce. It can not be guaranteed that it suppresses switching due to external system noise.

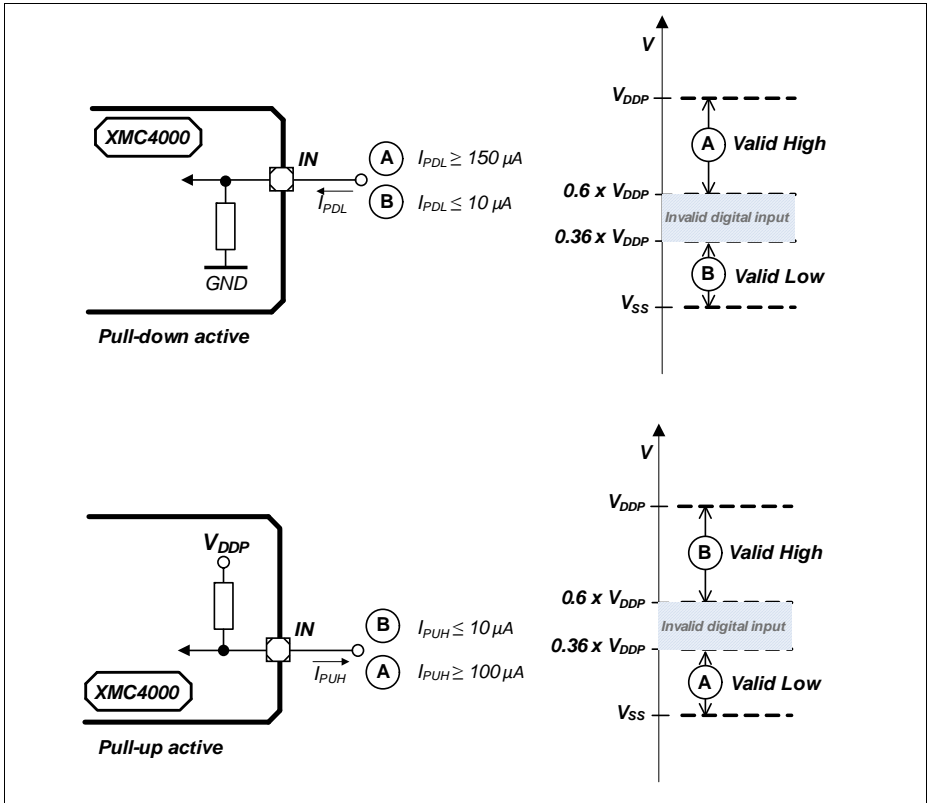

Figure 13 Pull Device Input Characteristics

Figure 13 visualizes the input characteristics with an active internal pull device:

- in the cases “A” the internal pull device is overridden by a strong external driver;
- in the cases “B” the internal pull device defines the input logical state against a weak external load.

Table 21 Standard Pads Class_A1

Parameter	Symbol	Values		Unit	Note / Test Condition
		Min.	Max.		
Input leakage current	I_{OZA1} CC	-500	500	nA	$0\text{ V} \leq V_{IN} \leq V_{DDP}$
Input high voltage	V_{IHA1} SR	$0.6 \times V_{DDP}$	$V_{DDP} + 0.3$	V	max. 3.6 V
Input low voltage	V_{ILA1} SR	-0.3	$0.36 \times V_{DDP}$	V	
Output high voltage, POD ¹⁾ = weak	V_{OHA1} CC	$V_{DDP} - 0.4$	–	V	$I_{OH} \geq -400\ \mu\text{A}$
		2.4	–	V	$I_{OH} \geq -500\ \mu\text{A}$
Output high voltage, POD ¹⁾ = medium		$V_{DDP} - 0.4$	–	V	$I_{OH} \geq -1.4\ \text{mA}$
		2.4	–	V	$I_{OH} \geq -2\ \text{mA}$
Output low voltage	V_{OLA1} CC	–	0.4	V	$I_{OL} \leq 500\ \mu\text{A}$; POD ¹⁾ = weak
		–	0.4	V	$I_{OL} \leq 2\ \text{mA}$; POD ¹⁾ = medium
Fall time	t_{FA1} CC	–	150	ns	$C_L = 20\ \text{pF}$; POD ¹⁾ = weak
		–	50	ns	$C_L = 50\ \text{pF}$; POD ¹⁾ = medium
Rise time	t_{RA1} CC	–	150	ns	$C_L = 20\ \text{pF}$; POD ¹⁾ = weak
		–	50	ns	$C_L = 50\ \text{pF}$; POD ¹⁾ = medium

1) POD = Pin Out Driver

Table 22 Standard Pads Class_A1+

Parameter	Symbol	Values		Unit	Note / Test Condition
		Min.	Max.		
Input leakage current	I_{OZA1+} CC	-1	1	μA	$0\text{ V} \leq V_{IN} \leq V_{DDP}$
Input high voltage	V_{IHA1+} SR	$0.6 \times V_{DDP}$	$V_{DDP} + 0.3$	V	max. 3.6 V
Input low voltage	V_{ILA1+} SR	-0.3	$0.36 \times V_{DDP}$	V	

Electrical Parameters
Table 22 Standard Pads Class_A1+

Parameter	Symbol	Values		Unit	Note / Test Condition	
		Min.	Max.			
Output high voltage, POD ¹⁾ = weak	V_{OHA1+} CC	$V_{DDP} - 0.4$	–	V	$I_{OH} \geq -400 \mu A$	
		2.4	–	V	$I_{OH} \geq -500 \mu A$	
Output high voltage, POD ¹⁾ = medium		$V_{DDP} - 0.4$	–	V	$I_{OH} \geq -1.4 mA$	
		2.4	–	V	$I_{OH} \geq -2 mA$	
Output high voltage, POD ¹⁾ = strong		$V_{DDP} - 0.4$	–	V	$I_{OH} \geq -1.4 mA$	
		2.4	–	V	$I_{OH} \geq -2 mA$	
Output low voltage		V_{OLA1+} CC	–	0.4	V	$I_{OL} \leq 500 \mu A$; POD ¹⁾ = weak
			–	0.4	V	$I_{OL} \leq 2 mA$; POD ¹⁾ = medium
	–		0.4	V	$I_{OL} \leq 2 mA$; POD ¹⁾ = strong	
Fall time	t_{FA1+} CC	–	150	ns	$C_L = 20 pF$; POD ¹⁾ = weak	
		–	50	ns	$C_L = 50 pF$; POD ¹⁾ = medium	
		–	28	ns	$C_L = 50 pF$; POD ¹⁾ = strong; edge = slow	
		–	16	ns	$C_L = 50 pF$; POD ¹⁾ = strong; edge = soft;	
Rise time	t_{RA1+} CC	–	150	ns	$C_L = 20 pF$; POD ¹⁾ = weak	
		–	50	ns	$C_L = 50 pF$; POD ¹⁾ = medium	
		–	28	ns	$C_L = 50 pF$; POD ¹⁾ = strong; edge = slow	
		–	16	ns	$C_L = 50 pF$; POD ¹⁾ = strong; edge = soft	

1) POD = Pin Out Driver

Table 23 Standard Pads Class_A2

Parameter	Symbol	Values		Unit	Note / Test Condition
		Min.	Max.		
Input Leakage current	I_{OZA2} CC	-6	6	μA	$0\text{ V} \leq V_{IN} < 0.5 \cdot V_{DDP} - 1\text{ V};$ $0.5 \cdot V_{DDP} + 1\text{ V} < V_{IN} \leq V_{DDP}$
		-3	3	μA	$0.5 \cdot V_{DDP} - 1\text{ V} < V_{IN} < 0.5 \cdot V_{DDP} + 1\text{ V}$
Input high voltage	V_{IHA2} SR	$0.6 \times V_{DDP}$	$V_{DDP} + 0.3$	V	max. 3.6 V
Input low voltage	V_{ILA2} SR	-0.3	$0.36 \times V_{DDP}$	V	
Output high voltage, POD = weak	V_{OHA2} CC	$V_{DDP} - 0.4$	-	V	$I_{OH} \geq -400\ \mu\text{A}$
		2.4	-	V	$I_{OH} \geq -500\ \mu\text{A}$
Output high voltage, POD = medium		$V_{DDP} - 0.4$	-	V	$I_{OH} \geq -1.4\ \text{mA}$
		2.4	-	V	$I_{OH} \geq -2\ \text{mA}$
Output high voltage, POD = strong		$V_{DDP} - 0.4$	-	V	$I_{OH} \geq -1.4\ \text{mA}$
		2.4	-	V	$I_{OH} \geq -2\ \text{mA}$
Output low voltage, POD = weak	V_{OLA2} CC	-	0.4	V	$I_{OL} \leq 500\ \mu\text{A}$
Output low voltage, POD = medium		-	0.4	V	$I_{OL} \leq 2\ \text{mA}$
Output low voltage, POD = strong		-	0.4	V	$I_{OL} \leq 2\ \text{mA}$

Electrical Parameters

Table 23 Standard Pads Class_A2

Parameter	Symbol	Values		Unit	Note / Test Condition
		Min.	Max.		
Fall time	t_{FA2} CC	–	150	ns	$C_L = 20$ pF; POD = weak
		–	50	ns	$C_L = 50$ pF; POD = medium
		–	3.7	ns	$C_L = 50$ pF; POD = strong; edge = sharp
		–	7	ns	$C_L = 50$ pF; POD = strong; edge = medium
		–	16	ns	$C_L = 50$ pF; POD = strong; edge = soft
Rise time	t_{RA2} CC	–	150	ns	$C_L = 20$ pF; POD = weak
		–	50	ns	$C_L = 50$ pF; POD = medium
		–	3.7	ns	$C_L = 50$ pF; POD = strong; edge = sharp
		–	7.0	ns	$C_L = 50$ pF; POD = strong; edge = medium
		–	16	ns	$C_L = 50$ pF; POD = strong; edge = soft

Table 24 HIB_IO Class_A1 special Pads

Parameter	Symbol	Values		Unit	Note / Test Condition
		Min.	Max.		
Input leakage current	I_{OZHIB} CC	-500	500	nA	$0\text{ V} \leq V_{IN} \leq V_{BAT}$
Input high voltage	V_{IHIB} SR	$0.6 \times V_{BAT}$	$V_{BAT} + 0.3$	V	max. 3.6 V
Input low voltage	V_{ILHIB} SR	-0.3	$0.36 \times V_{BAT}$	V	
Input Hysteresis for HIB_IO pins ¹⁾	$HYSHIB$ CC	$0.1 \times V_{BAT}$	–	V	$V_{BAT} \geq 3.13\text{ V}$
		$0.06 \times V_{BAT}$	–	V	$V_{BAT} < 3.13\text{ V}$
Output high voltage, POD ¹⁾ = medium	V_{OHIB} CC	$V_{BAT} - 0.4$	–	V	$I_{OH} \geq -1.4\text{ mA}$
Output low voltage	V_{OLHIB} CC	–	0.4	V	$I_{OL} \leq 2\text{ mA}$
Fall time	t_{FHIB} CC	–	50	ns	$V_{BAT} \geq 3.13\text{ V}$ $C_L = 50\text{ pF}$
		–	100	ns	$V_{BAT} < 3.13\text{ V}$ $C_L = 50\text{ pF}$
Rise time	t_{RHIB} CC	–	50	ns	$V_{BAT} \geq 3.13\text{ V}$ $C_L = 50\text{ pF}$
		–	100	ns	$V_{BAT} < 3.13\text{ V}$ $C_L = 50\text{ pF}$

1) Hysteresis is implemented to avoid metastable states and switching due to internal ground bounce. It can not be guaranteed that it suppresses switching due to external system noise.

3.2.2 Analog to Digital Converters (VADC)

Note: These parameters are not subject to production test, but verified by design and/or characterization.

Table 25 VADC Parameters (Operating Conditions apply)

Parameter	Symbol	Values			Unit	Note / Test Condition
		Min.	Typ.	Max.		
Analog reference voltage ⁵⁾	V_{AREF} SR	$V_{AGND} + 1$	–	$V_{DDA} + 0.05^{1)}$	V	
Analog reference ground ⁵⁾	V_{AGND} SR	$V_{SSM} - 0.05$	–	$V_{AREF} - 1$	V	
Analog reference voltage range ²⁾⁵⁾	$V_{AREF} - V_{AGND}$ SR	1	–	$V_{DDA} + 0.1$	V	
Analog input voltage	V_{AIN} SR	V_{AGND}	–	V_{DDA}	V	
Input leakage at analog inputs ³⁾	I_{OZ1} CC	-100	–	200	nA	$0.03 \times V_{DDA} < V_{AIN} < 0.97 \times V_{DDA}$
		-500	–	100	nA	$0 \text{ V} \leq V_{AIN} \leq 0.03 \times V_{DDA}$
		-100	–	500	nA	$0.97 \times V_{DDA} \leq V_{AIN} \leq V_{DDA}$
Input leakage current at VAREF	I_{OZ2} CC	-1	–	1	μA	$0 \text{ V} \leq V_{AREF} \leq V_{DDA}$
Input leakage current at VAGND	I_{OZ3} CC	-1	–	1	μA	$0 \text{ V} \leq V_{AGND} \leq V_{DDA}$
Internal ADC clock	f_{ADCI} CC	2	–	36	MHz	$V_{DDA} = 3.3 \text{ V}$
Switched capacitance at the analog voltage inputs ⁴⁾	C_{AINSW} CC	–	4	6.5	pF	
Total capacitance of an analog input	C_{AINTOT} CC	–	12	20	pF	
Switched capacitance at the positive reference voltage input ⁵⁾⁶⁾	C_{AREFSW} CC	–	15	30	pF	
Total capacitance of the voltage reference inputs ⁵⁾	$C_{AREFTOT}$ CC	–	20	40	pF	

Electrical Parameters
Table 25 VADC Parameters (Operating Conditions apply)

Parameter	Symbol	Values			Unit	Note / Test Condition
		Min.	Typ.	Max.		
Total Unadjusted Error	TUE_{CC}	-4	–	4	LSB	12-bit resolution; $V_{DDA} = 3.3\text{ V}$; $V_{AREF} = V_{DDA}$ ⁷⁾
Differential Non-Linearity Error ⁸⁾	$EA_{DNL_{CC}}$	-3	–	3	LSB	
Gain Error ⁸⁾	$EA_{GAIN_{CC}}$	-4	–	4	LSB	
Integral Non-Linearity ⁸⁾	$EA_{INL_{CC}}$	-3	–	3	LSB	
Offset Error ⁸⁾	$EA_{OFF_{CC}}$	-4	–	4	LSB	
RMS Noise ⁹⁾	$EN_{RMS_{CC}}$	–	1	2 ^{10/11)}	LSB	
Worst case ADC V_{DDA} power supply current per active converter	$I_{DDAA_{CC}}$	–	1.5	2	mA	during conversion $V_{DDP} = 3.6\text{ V}$, $T_J = 150\text{ °C}$
Charge consumption on V_{AREF} per conversion ⁵⁾	$Q_{CONV_{CC}}$	–	30	–	pC	$0\text{ V} \leq V_{AREF} \leq V_{DDA}$ ¹²⁾
ON resistance of the analog input path	$R_{AIN_{CC}}$	–	600	1 200	Ohm	
ON resistance for the ADC test (pull down for AIN7)	$R_{AIN7T_{CC}}$	180	550	900	Ohm	
Resistance of the reference voltage input path	$R_{AREF_{CC}}$	–	700	1 700	Ohm	

- 1) A running conversion may become imprecise in case the normal conditions are violated (voltage overshoot).
- 2) If the analog reference voltage is below V_{DDA} , then the ADC converter errors increase. If the reference voltage is reduced by the factor k ($k < 1$), TUE, DNL, INL, Gain, and Offset errors increase also by the factor 1/k.
- 3) The leakage current definition is a continuous function, as shown in figure ADCx Analog Inputs Leakage. The numerical values defined determine the characteristic points of the given continuous linear approximation - they do not define step function (see [Figure 16](#)).
- 4) The sampling capacity of the conversion C-network is pre-charged to $V_{AREF}/2$ before the sampling moment. Because of the parasitic elements, the voltage measured at AINx can deviate from $V_{AREF}/2$.
- 5) Applies to AINx, when used as alternate reference input.
- 6) This represents an equivalent switched capacitance. This capacitance is not switched to the reference voltage at once. Instead, smaller capacitances are successively switched to the reference voltage.
- 7) For 10-bit conversions, the errors are reduced to 1/4; for 8-bit conversions, the errors are reduced to 1/16. Never less than ± 1 LSB.
- 8) The sum of DNL/INL/GAIN/OFF errors does not exceed the related total unadjusted error TUE.

Electrical Parameters

- 9) This parameter is valid for soldered devices and requires careful analog board design.
- 10) Resulting worst case combined error is arithmetic combination of TUE and EN_{RMS} .
- 11) Value is defined for one sigma Gauss distribution.
- 12) The resulting current for a conversion can be calculated with $I_{AREF} = Q_{CONV} / t_c$.
The fastest 12-bit post-calibrated conversion of $t_c = 459$ ns results in a typical average current of $I_{AREF} = 65.4$ μ A.

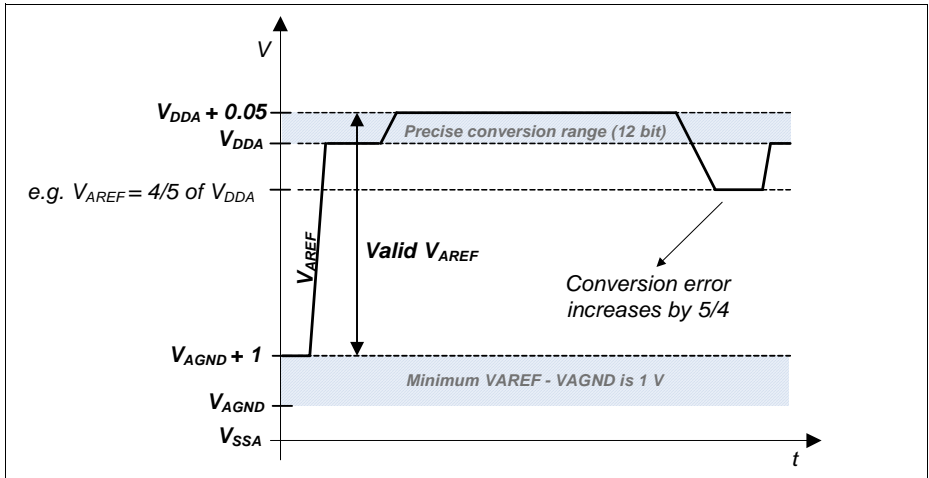

Figure 14 VADC Reference Voltage Range

The power-up calibration of the VADC requires a maximum number of $4 \cdot 352 \cdot f_{ADCI}$ cycles.

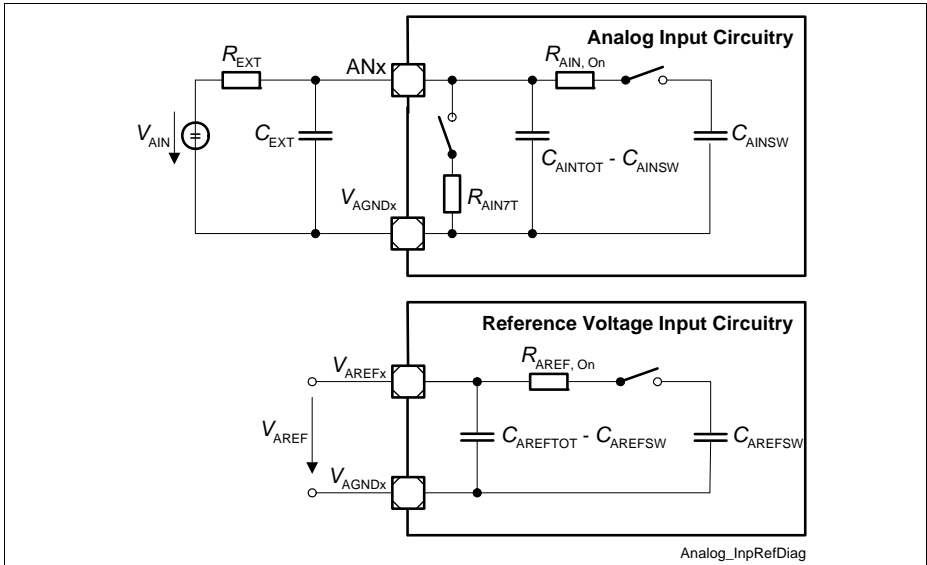

Figure 15 VADC Input Circuits

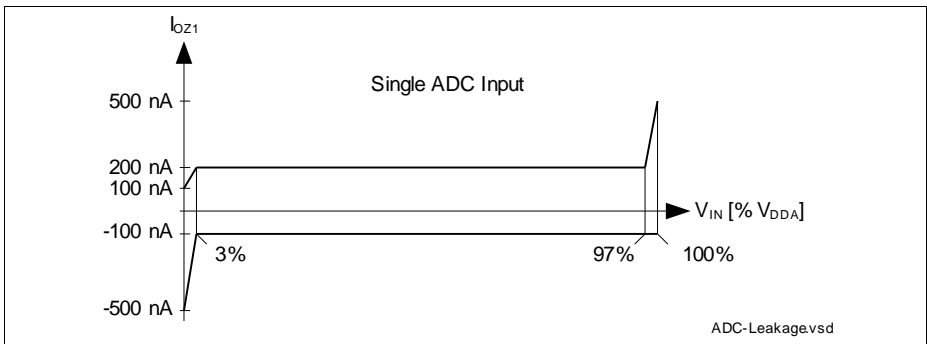

Figure 16 VADC Analog Input Leakage Current

Conversion Time
Table 26 Conversion Time (Operating Conditions apply)

Parameter	Symbol	Values	Unit	Note
Conversion time	t_C CC	$2 \times T_{ADC} + (2 + N + STC + PC + DM) \times T_{ADCI}$	μs	N = 8, 10, 12 for N-bit conversion $T_{ADC} = 1 / f_{PERIPH}$ $T_{ADCI} = 1 / f_{ADCI}$

- STC defines additional clock cycles to extend the sample time
- PC adds two cycles if post-calibration is enabled
- DM adds one cycle for an extended conversion time of the MSB

Conversion Time Examples

System assumptions:

$$f_{ADC} = 144 \text{ MHz i.e. } t_{ADC} = 6.9 \text{ ns, DIVA} = 3, f_{ADCI} = 36 \text{ MHz i.e. } t_{ADCI} = 27.8 \text{ ns}$$

According to the given formulas the following minimum conversion times can be achieved (STC = 0, DM = 0):

12-bit post-calibrated conversion (PC = 2):

$$t_{CN12C} = (2 + 12 + 2) \times t_{ADCI} + 2 \times t_{ADC} = 16 \times 27.8 \text{ ns} + 2 \times 6.9 \text{ ns} = 459 \text{ ns}$$

12-bit uncalibrated conversion:

$$t_{CN12} = (2 + 12) \times t_{ADCI} + 2 \times t_{ADC} = 14 \times 27.8 \text{ ns} + 2 \times 6.9 \text{ ns} = 403 \text{ ns}$$

10-bit uncalibrated conversion:

$$t_{CN10} = (2 + 10) \times t_{ADCI} + 2 \times t_{ADC} = 12 \times 27.8 \text{ ns} + 2 \times 6.9 \text{ ns} = 348 \text{ ns}$$

8-bit uncalibrated:

$$t_{CN8} = (2 + 8) \times t_{ADCI} + 2 \times t_{ADC} = 10 \times 27.8 \text{ ns} + 2 \times 6.9 \text{ ns} = 292 \text{ ns}$$

3.2.3 Digital to Analog Converters (DAC)

Note: These parameters are not subject to production test, but verified by design and/or characterization.

Electrical Parameters
Table 27 DAC Parameters (Operating Conditions apply)

Parameter	Symbol	CC	Values			Unit	Note / Test Condition
			Min.	Typ.	Max.		
RMS supply current	I_{DD}	CC	–	2.5	4	mA	per active DAC channel, without load currents of DAC outputs
Resolution	RES	CC	–	12	–	Bit	
Update rate	f_{URATE_A}	CC	–		2	Msample/s	data rate, where DAC can follow 64 LSB code jumps to ± 1 LSB accuracy
Update rate	f_{URATE_F}	CC	–		5	Msample/s	data rate, where DAC can follow 64 LSB code jumps to ± 4 LSB accuracy
Settling time	t_{SETTLE}	CC	–	1	2	μ s	at full scale jump, output voltage reaches target value ± 20 LSB
Slew rate	SR	CC	2	5	–	V/ μ s	
Minimum output voltage	V_{OUT_MIN}	CC	–	0.3	–	V	code value unsigned: 000 _H ; signed: 800 _H
Maximum output voltage	V_{OUT_MAX}	CC	–	2.5	–	V	code value unsigned: FFF _H ; signed: 7FF _H
Integral non-linearity	INL	CC	-5.5	± 2.5	5.5	LSB	$R_L \geq 5$ kOhm, $C_L \leq 50$ pF
Differential non-linearity	DNL	CC	-2	± 1	2	LSB	$R_L \geq 5$ kOhm, $C_L \leq 50$ pF
Offset error	ED_{OFF}	CC		± 20		mV	
Gain error	ED_{G_IN}	CC	-6.5	-1.5	3	%	
Startup time	$t_{STARTUP}$	CC	–	15	30	μ s	time from output enabling till code valid ± 16 LSB

Table 27 DAC Parameters (Operating Conditions apply) (cont'd)

Parameter	Symbol		Values			Unit	Note / Test Condition
			Min.	Typ.	Max.		
3dB Bandwidth of Output Buffer	f_{C1}	CC	2.5	5	–	MHz	verified by design
Output sourcing current	I_{OUT_SOURCE}	CC	–	-30	–	mA	
Output sinking current	I_{OUT_SINK}	CC	–	0.6	–	mA	
Output resistance	R_{OUT}	CC	–	50	–	Ohm	
Load resistance	R_L	SR	5	–	–	kOhm	
Load capacitance	C_L	SR	–	–	50	pF	
Signal-to-Noise Ratio	SNR	CC	–	70	–	dB	examination bandwidth < 25 kHz
Total Harmonic Distortion	THD	CC	–	70	–	dB	examination bandwidth < 25 kHz
Power Supply Rejection Ratio	PSRR	CC	–	56	–	dB	to V_{DDA} verified by design

Conversion Calculation

Unsigned:

$$DACxDATA = 4095 \times (V_{OUT} - V_{OUT_MIN}) / (V_{OUT_MAX} - V_{OUT_MIN})$$

Signed:

$$DACxDATA = 4095 \times (V_{OUT} - V_{OUT_MIN}) / (V_{OUT_MAX} - V_{OUT_MIN}) - 2048$$

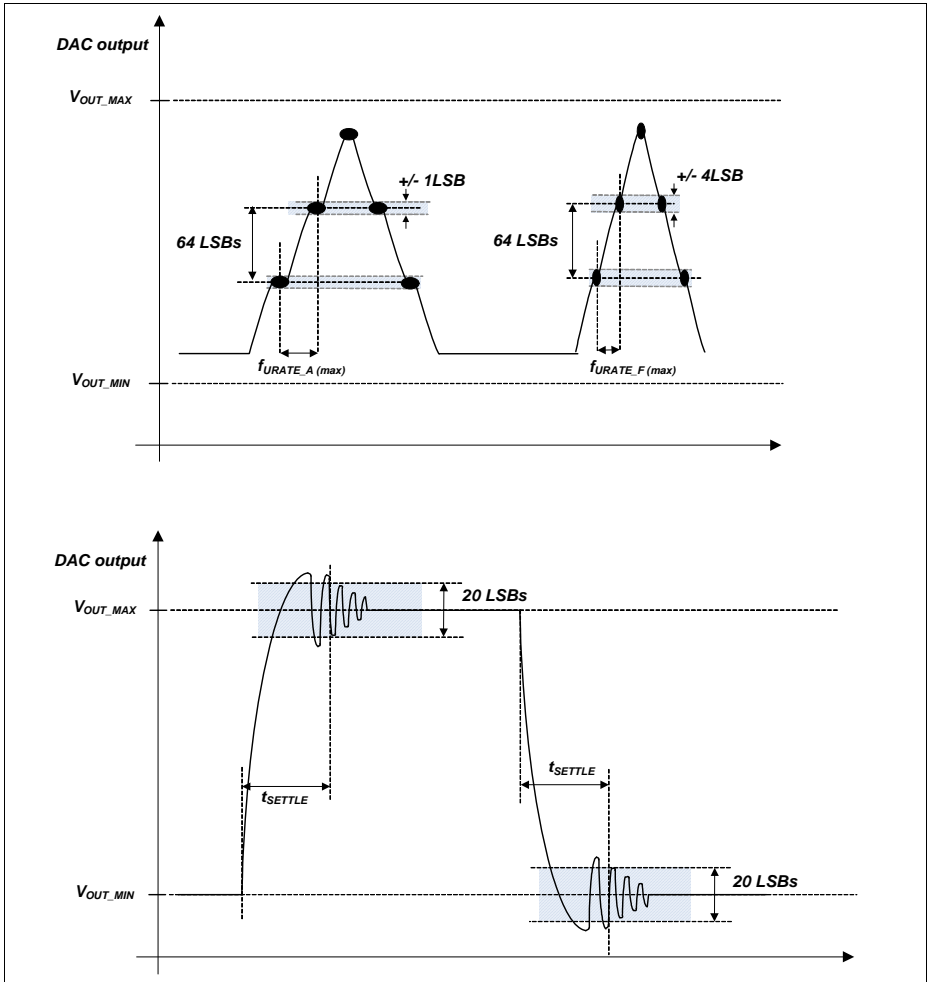

Figure 17 DAC Conversion Examples

3.2.4 Out-of-Range Comparator (ORC)

The Out-of-Range Comparator (ORC) triggers on analog input voltages (V_{AIN}) above the analog reference¹⁾ (V_{AREF}) on selected input pins (GxORCy) and generates a service request trigger (GxORCOUTy).

Note: These parameters are not subject to production test, but verified by design and/or characterization.

The parameters in **Table 28** apply for the maximum reference voltage $V_{AREF} = V_{DDA} + 50 \text{ mV}$.

Table 28 ORC Parameters (Operating Conditions apply)

Parameter	Symbol		Values			Unit	Note / Test Condition
			Min.	Typ.	Max.		
DC Switching Level	V_{ODC}	CC	100	125	210	mV	$V_{AIN} \geq V_{AREF} + V_{ODC}$
Hysteresis	V_{OHYS}	CC	50	–	V_{ODC}	mV	
Detection Delay of a persistent Overvoltage	t_{ODD}	CC	50	–	450	ns	$V_{AIN} \geq V_{AREF} + 210 \text{ mV}$
			45	–	105	ns	$V_{AIN} \geq V_{AREF} + 400 \text{ mV}$
Always detected Overvoltage Pulse	t_{OPDD}	CC	440	–	–	ns	$V_{AIN} \geq V_{AREF} + 210 \text{ mV}$
			90	–	–	ns	$V_{AIN} \geq V_{AREF} + 400 \text{ mV}$
Never detected Overvoltage Pulse	t_{OPDN}	CC	–	–	45	ns	$V_{AIN} \geq V_{AREF} + 210 \text{ mV}$
			–	–	30	ns	$V_{AIN} \geq V_{AREF} + 400 \text{ mV}$
Release Delay	t_{ORD}	CC	65	–	105	ns	$V_{AIN} \leq V_{AREF}$
Enable Delay	t_{OED}	CC	–	100	200	ns	

1) Always the standard VADC reference, alternate references do not apply to the ORC.

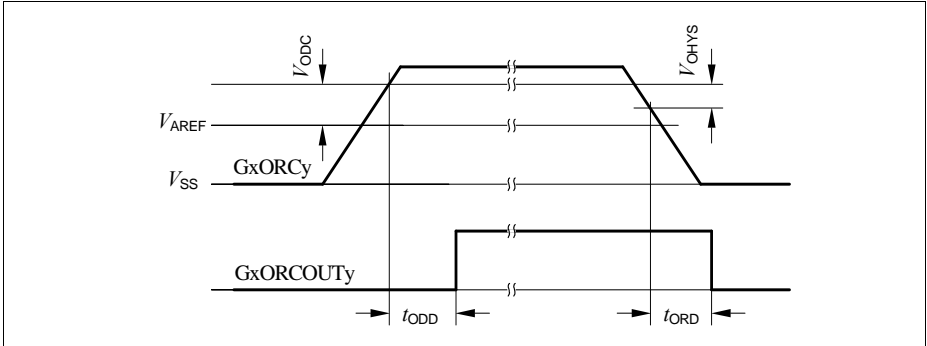

Figure 18 GxORCOUTy Trigger Generation

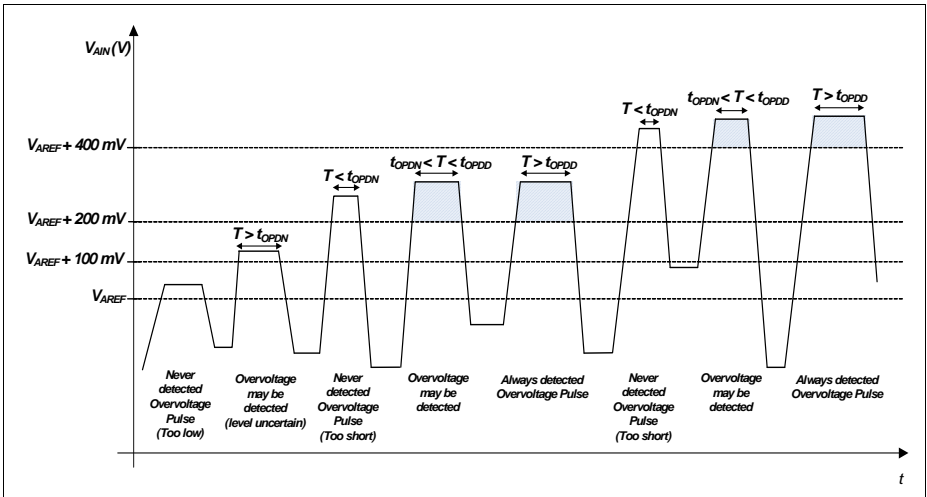

Figure 19 ORC Detection Ranges

3.2.5 Die Temperature Sensor

The Die Temperature Sensor (DTS) measures the junction temperature T_J .

Note: These parameters are not subject to production test, but verified by design and/or characterization.

Table 29 Die Temperature Sensor Parameters

Parameter	Symbol	Values			Unit	Note / Test Condition
		Min.	Typ.	Max.		
Temperature sensor range	T_{SR} SR	-40	–	150	°C	
Linearity Error (to the below defined formula)	ΔT_{LE} CC	–	±1	–	°C	per $\Delta T_J \leq 30$ °C
Offset Error	ΔT_{OE} CC	–	±6	–	°C	$\Delta T_{OE} = T_J - T_{DTS}$ $V_{DDP} \leq 3.3$ V ¹⁾
Measurement time	t_M CC	–	–	100	µs	
Start-up time after reset inactive	t_{TSST} SR	–	–	10	µs	

1) At $V_{DDP_max} = 3.63$ V the typical offset error increases by an additional $\Delta T_{OE} = \pm 1$ °C.

The following formula calculates the temperature measured by the DTS in [°C] from the RESULT bit field of the DTSSTAT register.

$$\text{Temperature } T_{DTS} = (\text{RESULT} - 605) / 2.05 \text{ [°C]}$$

This formula and the values defined in [Table 29](#) apply with the following calibration values:

- DTSCON.BGTRIM = 8_H
- DTSCON.REFTRIM = 4_H

3.2.6 USB OTG Interface DC Characteristics

The Universal Serial Bus (USB) Interface is compliant to the USB Rev. 2.0 Specification and the OTG Specification Rev. 1.3. High-Speed Mode is not supported.

Note: These parameters are not subject to production test, but verified by design and/or characterization.

Table 30 USB OTG VBUS and ID Parameters (Operating Conditions apply)

Parameter	Symbol	Values			Unit	Note / Test Condition
		Min.	Typ.	Max.		
VBUS input voltage range	V_{IN} CC	0.0	–	5.25	V	
A-device VBUS valid threshold	V_{B1} CC	4.4	–	–	V	
A-device session valid threshold	V_{B2} CC	0.8	–	2.0	V	
B-device session valid threshold	V_{B3} CC	0.8	–	4.0	V	
B-device session end threshold	V_{B4} CC	0.2	–	0.8	V	
VBUS input resistance to ground	R_{VBUS_IN} CC	40	–	100	kOhm	
B-device VBUS pull-up resistor	R_{VBUS_PU} CC	281	–	–	Ohm	Pull-up voltage = 3.0 V
B-device VBUS pull-down resistor	R_{VBUS_PD} CC	656	–	–	Ohm	
USB.ID pull-up resistor	R_{UID_PU} CC	14	–	25	kOhm	
VBUS input current	I_{VBUS_IN} CC	–	–	150	μ A	$0\text{ V} \leq V_{IN} \leq 5.25\text{ V}$: $T_{AVG} = 1\text{ ms}$

Table 31 USB OTG Data Line (USB_DP, USB_DM) Parameters (Operating Conditions apply)

Parameter	Symbol	Values			Unit	Note / Test Condition
		Min.	Typ.	Max.		
Input low voltage	V_{IL} SR	–	–	0.8	V	
Input high voltage (driven)	V_{IH} SR	2.0	–	–	V	
Input high voltage (floating) ¹⁾	V_{IHZ} SR	2.7	–	3.6	V	
Differential input sensitivity	V_{DIS} CC	0.2	–	–	V	
Differential common mode range	V_{CM} CC	0.8	–	2.5	V	
Output low voltage	V_{OL} CC	0.0	–	0.3	V	1.5 kOhm pull-up to 3.6 V
Output high voltage	V_{OH} CC	2.8	–	3.6	V	15 kOhm pull-down to 0 V
DP pull-up resistor (idle bus)	R_{PUI} CC	900	–	1 575	Ohm	
DP pull-up resistor (upstream port receiving)	R_{PUA} CC	1 425	–	3 090	Ohm	
DP, DM pull-down resistor	R_{PD} CC	14.25	–	24.8	kOhm	
Input impedance DP, DM	Z_{INP} CC	300	–	–	kOhm	$0 V \leq V_{IN} \leq V_{DDP}$
Driver output resistance DP, DM	Z_{DRV} CC	28	–	44	Ohm	

1) Measured at A-connector with 1.5 kOhm \pm 5% to 3.3 V \pm 0.3 V connected to USB_DP or USB_DM and at B-connector with 15 kOhm \pm 5% to ground connected to USB_DP and USB_DM.

3.2.7 Oscillator Pins

Note: It is strongly recommended to measure the oscillation allowance (negative resistance) in the final target system (layout) to determine the optimal parameters for the oscillator operation. Please refer to the limits specified by the crystal or ceramic resonator supplier.

Note: These parameters are not subject to production test, but verified by design and/or characterization.

The oscillator pins can be operated with an external crystal (see [Figure 20](#)) or in direct input mode (see [Figure 21](#)).

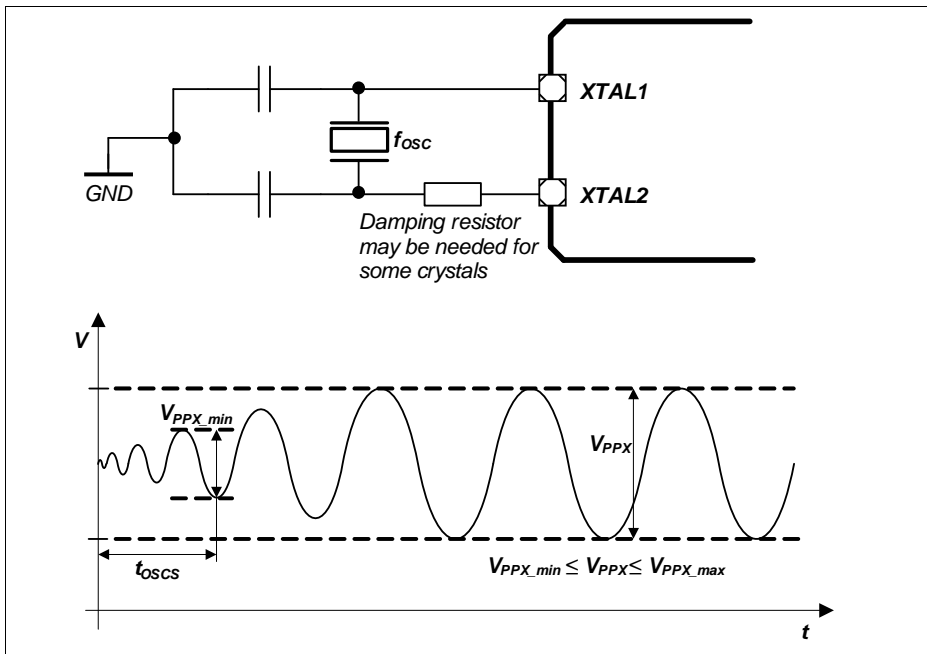

Figure 20 Oscillator in Crystal Mode

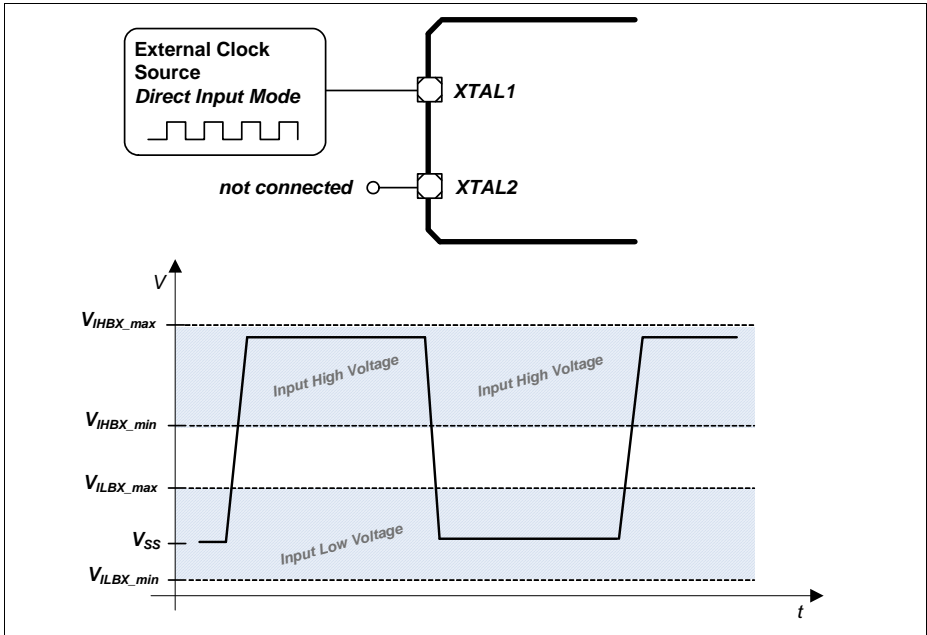

Figure 21 Oscillator in Direct Input Mode

Table 32 OSC_XTAL Parameters

Parameter	Symbol	Values			Unit	Note / Test Condition
		Min.	Typ.	Max.		
Input frequency	f_{OSC} SR	4	–	40	MHz	Direct Input Mode selected
		4	–	25	MHz	External Crystal Mode selected
Oscillator start-up time ¹⁾²⁾	t_{OSCS} CC	–	–	10	ms	
Input voltage at XTAL1	V_{IX} SR	-0.5	–	$V_{\text{DDP}} + 0.5$	V	
Input amplitude (peak-to-peak) at XTAL1 ²⁾³⁾	V_{PPX} SR	$0.4 \times V_{\text{DDP}}$	–	$V_{\text{DDP}} + 1.0$	V	
Input high voltage at XTAL1 ⁴⁾	V_{IHBX} SR	1.0	–	$V_{\text{DDP}} + 0.5$	V	
Input low voltage at XTAL1 ⁴⁾	V_{ILBX} SR	-0.5	–	0.4	V	
Input leakage current at XTAL1	I_{ILX1} CC	-100	–	100	nA	Oscillator power down $0 \text{ V} \leq V_{\text{IX}} \leq V_{\text{DDP}}$

1) t_{OSCS} is defined from the moment the oscillator is enabled with SCU_OSCHPCTRL.MODE until the oscillations reach an amplitude at XTAL1 of $0.4 \cdot V_{\text{DDP}}$.

2) The external oscillator circuitry must be optimized by the customer and checked for negative resistance and amplitude as recommended and specified by crystal suppliers.

3) If the shaper unit is enabled and not bypassed.

4) If the shaper unit is bypassed, dedicated DC-thresholds have to be met.

Table 33 RTC_XTAL Parameters

Parameter	Symbol	Values			Unit	Note / Test Condition
		Min.	Typ.	Max.		
Input frequency	f_{OSC} SR	–	32.768	–	kHz	
Oscillator start-up time ¹⁾²⁾³⁾	t_{OSCS} CC	–	–	5	s	
Input voltage at RTC_XTAL1	V_{IX} SR	-0.3	–	$V_{BAT} + 0.3$	V	
Input amplitude (peak-to-peak) at RTC_XTAL1 ²⁾⁴⁾	V_{PPX} SR	0.4	–	–	V	
Input high voltage at RTC_XTAL1 ⁵⁾	V_{IHBX} SR	$0.6 \times V_{BAT}$	–	$V_{BAT} + 0.3$	V	
Input low voltage at RTC_XTAL1 ⁵⁾	V_{ILBX} SR	-0.3	–	$0.36 \times V_{BAT}$	V	
Input Hysteresis for RTC_XTAL1 ⁵⁾⁶⁾	V_{HYSX} CC	$0.1 \times V_{BAT}$		–	V	$3.0 \text{ V} \leq V_{BAT} < 3.6 \text{ V}$
		$0.03 \times V_{BAT}$		–	V	$V_{BAT} < 3.0 \text{ V}$
Input leakage current at RTC_XTAL1	I_{ILX1} CC	-100	–	100	nA	Oscillator power down $0 \text{ V} \leq V_{IX} \leq V_{BAT}$

- 1) t_{OSCS} is defined from the moment the oscillator is enabled by the user with SCU_OSCULCTRL.MODE until the oscillations reach an amplitude at RTC_XTAL1 of 400 mV.
- 2) The external oscillator circuitry must be optimized by the customer and checked for negative resistance and amplitude as recommended and specified by crystal suppliers.
- 3) For a reliable start of the oscillation in crystal mode it is required that $V_{BAT} \geq 3.0 \text{ V}$. A running oscillation is maintained across the full V_{BAT} voltage range.
- 4) If the shaper unit is enabled and not bypassed.
- 5) If the shaper unit is bypassed, dedicated DC-thresholds have to be met.
- 6) Hysteresis is implemented to avoid metastable states and switching due to internal ground bounce. It can not be guaranteed that it suppresses switching due to external system noise.

3.2.8 Power Supply Current

The total power supply current defined below consists of a leakage and a switching component.

Application relevant values are typically lower than those given in the following tables, and depend on the customer's system operating conditions (e.g. thermal connection or used application configurations).

Note: These parameters are not subject to production test, but verified by design and/or characterization.

If not stated otherwise, the operating conditions for the parameters in the following table are:

$$V_{DDP} = 3.3 \text{ V}, T_A = 25 \text{ }^{\circ}\text{C}$$

Table 34 Power Supply Parameters

Parameter	Symbol	Values			Unit	Note / Test Condition
		Min.	Typ.	Max.		
Active supply current ⁽¹⁾⁽¹⁾ Peripherals enabled Frequency: $f_{CPU} / f_{PERIPH} / f_{CCU}$ in MHz	I_{DDPA} CC	-	135	-	mA	144 / 144 / 144
		-	125	-		144 / 72 / 72
		-	97	-		72 / 72 / 144
		-	80	-		24 / 24 / 24
		-	68	-		1 / 1 / 1
Active supply current Code execution from RAM Flash in Sleep mode	I_{DDPA} CC	-	108	-	mA	144 / 144 / 144
		-	98	-		144 / 72 / 72
Active supply current ⁽²⁾ Peripherals disabled Frequency: $f_{CPU} / f_{PERIPH} / f_{CCU}$ in MHz	I_{DDPA} CC	-	86	-	mA	144 / 144 / 144
		-	85	-		144 / 72 / 72
		-	70	-		72 / 72 / 144
		-	55	-		24 / 24 / 24
		-	50	-		1 / 1 / 1
Sleep supply current ⁽³⁾ Peripherals enabled Frequency: $f_{CPU} / f_{PERIPH} / f_{CCU}$ in MHz	I_{DDPS} CC	-	127	-	mA	144 / 144 / 144
		-	115	-		144 / 72 / 72
		-	93	-		72 / 72 / 144
		-	57	-		24 / 24 / 24
		-	47	-		1 / 1 / 1
		$f_{CPU} / f_{PERIPH} / f_{CCU}$ in kHz	-	48		-

Table 34 Power Supply Parameters

Parameter	Symbol	Values			Unit	Note / Test Condition
		Min.	Typ.	Max.		
Sleep supply current ⁴⁾ Peripherals disabled Frequency: $f_{CPU} / f_{PERIPH} / f_{CCU}$ in MHz	I_{DDPS} CC	-	77	-	mA	144 / 144 / 144
		-	76	-		144 / 72 / 72
		-	65	-		72 / 72 / 144
		-	53	-		24 / 24 / 24
		-	46	-		1 / 1 / 1
		-	47	-		100 / 100 / 100
$f_{CPU} / f_{PERIPH} / f_{CCU}$ in kHz						
Deep Sleep supply current ⁵⁾ Flash in Sleep mode Frequency: $f_{CPU} / f_{PERIPH} / f_{CCU}$ in MHz $f_{CPU} / f_{PERIPH} / f_{CCU}$ in kHz	I_{DDPD} CC	-	11	-	mA	24 / 24 / 24
		-	7.0	-		4 / 4 / 4
		-	6.6	-		1 / 1 / 1
		-	7.6	-		100 / 100 / 100 ⁶⁾
Hibernate supply current RTC on ⁷⁾	I_{DDPH} CC	-	8.7	-	μ A	$V_{BAT} = 3.3$ V
		-	6.5	-		$V_{BAT} = 2.4$ V
		-	5.7	-		$V_{BAT} = 2.0$ V
Hibernate supply current RTC off ⁸⁾	I_{DDPH} CC	-	8.0	-	μ A	$V_{BAT} = 3.3$ V
		-	6.0	-		$V_{BAT} = 2.4$ V
		-	5.0	-		$V_{BAT} = 2.0$ V
Hibernate off ⁹⁾	I_{DDPH} CC	-	4.4	-	μ A	$V_{BAT} = 3.3$ V
		-	3.5	-		$V_{BAT} = 2.4$ V
		-	3.1	-		$V_{BAT} = 2.0$ V
Worst case active supply current ¹⁰⁾	I_{DDPA} CC	-	-	250 ¹¹⁾	mA	$V_{DDP} = 3.6$ V, $T_J = 150$ °C
V_{DDA} power supply current	I_{DDA} CC	-	-	- ¹²⁾	mA	
I_{DDP} current at PORST Low	I_{DDP_PORST} CC	-	5	10	mA	$V_{DDP} = 3.3$ V, $T_J = 25$ °C
		-	13	55	mA	$V_{DDP} = 3.6$ V, $T_J = 150$ °C
Power Dissipation	P_{DISS} CC	-	-	1.4	W	$V_{DDP} = 3.6$ V, $T_J = 150$ °C

Table 34 Power Supply Parameters

Parameter	Symbol	Values			Unit	Note / Test Condition
		Min.	Typ.	Max.		
Wake-up time from Sleep to Active mode	t_{SSA} CC	–	6	–	cycles	
Wake-up time from Deep Sleep to Active mode		–	–	–	ms	Defined by the wake-up of the Flash module, see Section 3.2.9
Wake-up time from Hibernate mode		–	–	–	ms	Wake-up via power-on reset event, see Section 3.3.2

- 1) CPU executing code from Flash, all peripherals idle.
- 2) CPU executing code from Flash.
- 3) CPU in sleep, all peripherals idle, Flash in Active mode.
- 4) CPU in sleep, Flash in Active mode.
- 5) CPU in sleep, peripherals disabled, after wake-up code execution from RAM.
- 6) To wake-up the Flash from its Sleep mode, $f_{CPU} \geq 1$ MHz is required.
- 7) OSC_ULP operating with external crystal on RTC_XTAL
- 8) OSC_ULP off, Hibernate domain operating with OSC_Sl clock
- 9) V_{BAT} supplied, but Hibernate domain not started; for example state after factory assembly
- 10) Test Power Loop: $f_{SYS} = 144$ MHz, CPU executing benchmark code from Flash, all CCUs in 100kHz timer mode, all ADC groups in continuous conversion mode, USICs as SPI in internal loop-back mode, CAN in 500kHz internal loop-back mode, interrupt triggered DMA block transfers to parity protected RAMs and FCE, DTS measurements and FPU calculations.
The power consumption of each customer application will most probably be lower than this value, but must be evaluated separately.
- 11) I_{DDP} decreases typically by approximately 5 mA when f_{SYS} decreases by 10 MHz, at constant T_J
- 12) Sum of currents of all active converters (ADC and DAC)

Peripheral Idle Currents

Default test conditions:

- f_{sys} and derived clocks at 144 MHz
- $V_{DDP} = 3.3\text{ V}$, $T_a = 25\text{ °C}$
- all peripherals are held in reset (see the PRSTAT registers in the Reset Control Unit of the SCU)
- the peripheral clocks are disabled (see CGATSTAT registers in the Clock Control Unit of the SCU)
- no I/O activity

The given values are a result of differential measurements with asserted and deasserted peripheral reset as well as disabled and enabled clock of the peripheral under test.

The tested peripheral is left in the state after the peripheral reset is deasserted, no further initialisation or configuration is done. E.g. no timer is running in the CCUs, no communication active in the USICs, etc.

Table 35 Peripheral Idle Currents

Parameter	Symbol	Values			Unit	Note / Test Condition
		Min.	Typ.	Max.		
PORTS FCE WDT POSIFx ¹⁾	$I_{PER\ CC}$	–	≤ 0.3	–	mA	
MultiCAN ERU LEDTSCU0 ETH CCU4x ¹⁾ , CCU8x ¹⁾		–	≤ 1.0	–		
DAC (digital) ²⁾		–	1.3	–		
USICx DMA1 SDMMC		–	3.0	–		
DSD, EBU VADC (digital) ²⁾		–	4.5	–		
DMA0, USB, EtherCAT		–	6.0	–		

1) Enabling the f_{CCU} clock for the POSIFx/CCU4x/CCU8x modules adds approximately $I_{PER} = 4.8\text{ mA}$, disregarding which and how many of those peripherals are enabled.

2) The current consumption of the analog components are given in the dedicated Data Sheet sections of the respective peripheral.

3.2.9 Flash Memory Parameters

Note: These parameters are not subject to production test, but verified by design and/or characterization.

Table 36 Flash Memory Parameters

Parameter	Symbol	Values			Unit	Note / Test Condition
		Min.	Typ.	Max.		
Erase Time per 256 Kbyte Sector	t_{ERP} CC	–	5	5.5	s	
Erase Time per 64 Kbyte Sector	t_{ERP} CC	–	1.2	1.4	s	
Erase Time per 16 Kbyte Logical Sector	t_{ERP} CC	–	0.3	0.4	s	
Program time per page ¹⁾	t_{PRP} CC	–	5.5	11	ms	
Erase suspend delay	t_{FL_ErSusp} CC	–	–	15	ms	
Wait time after margin change	$t_{FL_MarginDel}$ CC	10	–	–	μs	
Wake-up time	t_{WU} CC	–	–	270	μs	
Read access time	t_a CC	22	–	–	ns	For operation with $1/f_{CPU} < t_a$ wait states must be configured ²⁾
Data Retention Time, Physical Sector ³⁾⁴⁾	t_{RET} CC	20	–	–	years	Max. 1000 erase/program cycles
Data Retention Time, Logical Sector ³⁾⁴⁾	t_{RETL} CC	20	–	–	years	Max. 100 erase/program cycles
Data Retention Time, User Configuration Block (UCB) ³⁾⁴⁾	t_{RTU} CC	20	–	–	years	Max. 4 erase/program cycles per UCB
Endurance on 64 Kbyte Physical Sector PS4	N_{EPS4} CC	10000	–	–	cycles	Cycling distributed over life time ⁵⁾

Electrical Parameters

- 1) In case the Program Verify feature detects weak bits, these bits will be programmed once more. The reprogramming takes an additional time of 5.5 ms.
- 2) The following formula applies to the wait state configuration: $FCON.WSPFLASH \times (1 / f_{CPU}) \geq t_a$.
- 3) Storage and inactive time included.
- 4) Values given are valid for an average weighted junction temperature of $T_J = 110^\circ\text{C}$.
- 5) Only valid with robust EEPROM emulation algorithm, equally cycling the logical sectors. For more details see the Reference Manual.

3.3 AC Parameters

3.3.1 Testing Waveforms

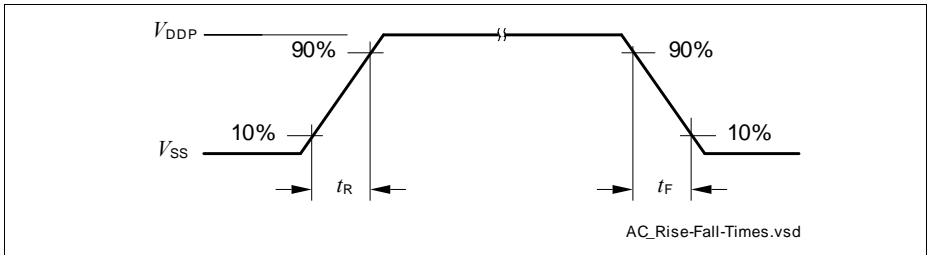

Figure 22 Rise/Fall Time Parameters

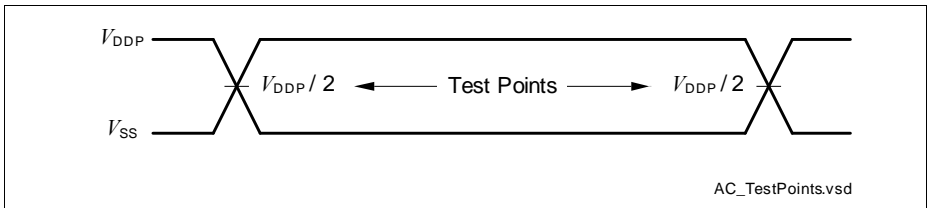

Figure 23 Testing Waveform, Output Delay

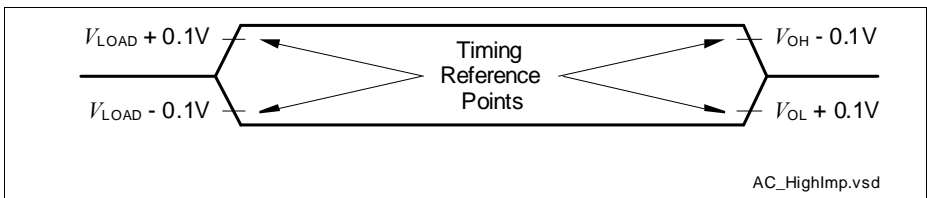

Figure 24 Testing Waveform, Output High Impedance

3.3.2 Power-Up and Supply Monitoring

$\overline{\text{PORST}}$ is always asserted when V_{DDP} and/or V_{DDC} violate the respective thresholds.

Note: These parameters are not subject to production test, but verified by design and/or characterization.

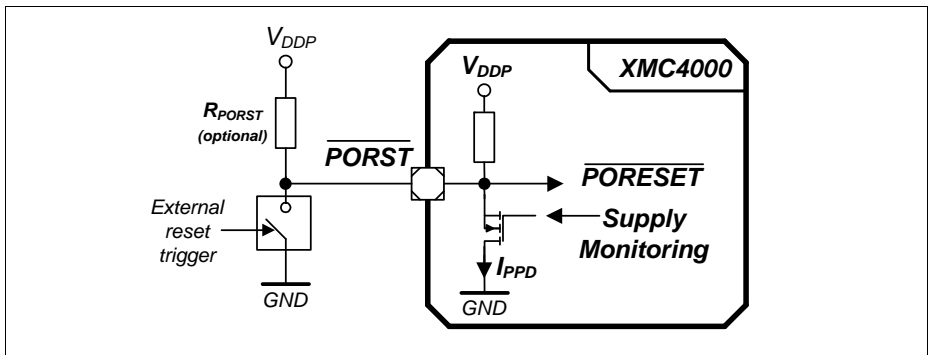

Figure 25 $\overline{\text{PORST}}$ Circuit

Table 37 Supply Monitoring Parameters

Parameter	Symbol	Values			Unit	Note / Test Condition
		Min.	Typ.	Max.		
Digital supply voltage reset threshold	V_{POR} CC	2.79 ¹⁾	–	3.05 ²⁾	V	3)
Core supply voltage reset threshold	V_{PV} CC	–	–	1.17	V	
V_{DDP} voltage to ensure defined pad states	V_{DDPPA} CC	–	1.0	–	V	
$\overline{\text{PORST}}$ rise time	t_{PR} SR	–	–	2	μs	4)
Startup time from power-on reset with code execution from Flash	t_{SSW} CC	–	2.5	3.5	ms	Time to the first user code instruction
V_{DDC} ramp up time	t_{VCR} CC	–	550	–	μs	Ramp up after power-on or after a reset triggered by a violation of V_{POR} or V_{PV}

1) Minimum threshold for reset assertion.

- 2) Maximum threshold for reset deassertion.
- 3) The V_{DDP} monitoring has a typical hysteresis of $V_{PORHYS} = 180$ mV.
- 4) If t_{PR} is not met, low spikes on \overline{PORST} may be seen during start up (e.g. reset pulses generated by the supply monitoring due to a slow ramping V_{DDP}).

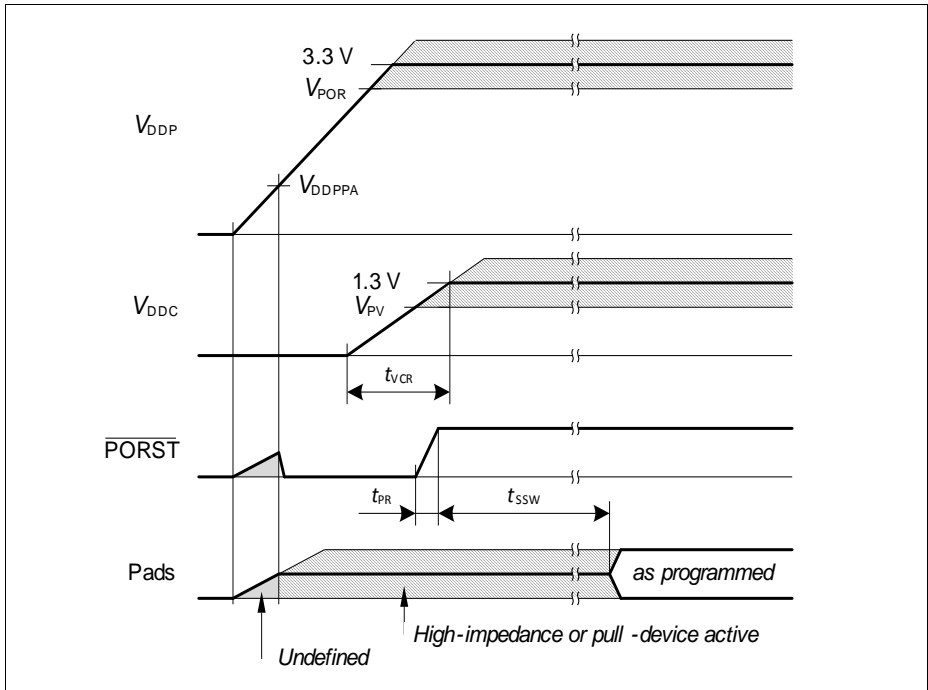

Figure 26 Power-Up Behavior

3.3.3 Power Sequencing

While starting up and shutting down as well as when switching power modes of the system it is important to limit the current load steps. A typical cause for such load steps is changing the CPU frequency f_{CPU} . Load steps exceeding the below defined values may cause a power on reset triggered by the supply monitor.

Note: These parameters are not subject to production test, but verified by design and/or characterization.

Table 38 Power Sequencing Parameters

Parameter	Symbol	Values			Unit	Note / Test Condition
		Min.	Typ.	Max.		
Positive Load Step Current	ΔI_{PLS} SR	-	-	50	mA	Load increase on V_{DDP} $\Delta t \leq 10$ ns
Negative Load Step Current	ΔI_{NLS} SR	-	-	150	mA	Load decrease on V_{DDP} $\Delta t \leq 10$ ns
V_{DDC} Voltage Over- / Undershoot from Load Step	ΔV_{LS} CC	-	-	± 100	mV	For maximum positive or negative load step
Positive Load Step Settling Time	t_{PLSS} SR	50	-	-	μ s	
Negative Load Step Settling Time	t_{NLSS} SR	100	-	-	μ s	
External Buffer Capacitor on V_{DDC}	C_{EXT} SR	-	10	-	μ F	In addition $C = 100$ nF capacitor on each V_{DDC} pin

Positive Load Step Examples

System assumptions:

$f_{CPU} = f_{SYS}$, target frequency $f_{CPU} = 144$ MHz, main PLL $f_{VCO} = 288$ MHz, stepping done by K2 divider, t_{PLSS} between individual steps:

24 MHz - 48 MHz - 72 MHz - 96 MHz - 144 MHz (K2 steps 12 - 6 - 4 - 3 - 2)

24 MHz - 48 MHz - 96 MHz - 144 MHz (K2 steps 12 - 6 - 3 - 2)

24 MHz - 72 MHz - 144 MHz (K2 steps 12 - 4 - 2)

3.3.4 Phase Locked Loop (PLL) Characteristics

Note: These parameters are not subject to production test, but verified by design and/or characterization.

Main and USB PLL

Table 39 PLL Parameters

Parameter	Symbol	Values			Unit	Note / Test Condition
		Min.	Typ.	Max.		
Accumulated Jitter	D_P CC	–	–	±5	ns	accumulated over 300 cycles $f_{SYS} = 144$ MHz
Duty Cycle ¹⁾	D_{DC} CC	46	50	54	%	Low pulse to total period, assuming an ideal input clock source
PLL base frequency	$f_{PLLBASE}$ CC	30	–	140	MHz	
VCO input frequency	f_{REF} CC	4	–	16	MHz	
VCO frequency range	f_{VCO} CC	260	–	520	MHz	
PLL lock-in time	t_L CC	–	–	400	µs	

1) 50% for even K2 divider values, 50±(10/K2) for odd K2 divider values.

3.3.5 Internal Clock Source Characteristics

Note: These parameters are not subject to production test, but verified by design and/or characterization.

Fast Internal Clock Source

Table 40 Fast Internal Clock Parameters

Parameter	Symbol	Values			Unit	Note / Test Condition
		Min.	Typ.	Max.		
Nominal frequency	f_{OFINC} CC	–	36.5	–	MHz	not calibrated
		–	24	–	MHz	calibrated
Accuracy	Δf_{OFI} CC	-0.5	–	0.5	%	automatic calibration ¹⁾²⁾
		-15	–	15	%	factory calibration, $V_{\text{DDP}} = 3.3 \text{ V}$
		-25	–	25	%	no calibration, $V_{\text{DDP}} = 3.3 \text{ V}$
		-7	–	7	%	Variation over voltage range ³⁾ $3.13 \text{ V} \leq V_{\text{DDP}} \leq 3.63 \text{ V}$
Start-up time	t_{OFIS} CC	–	50	–	μs	

1) Error in addition to the accuracy of the reference clock.

2) Automatic calibration compensates variations of the temperature and in the V_{DDP} supply voltage.

3) Deviations from the nominal V_{DDP} voltage induce an additional error to the uncalibrated and/or factory calibrated oscillator frequency.

Slow Internal Clock Source

Table 41 Slow Internal Clock Parameters

Parameter	Symbol	Values			Unit	Note / Test Condition
		Min.	Typ.	Max.		
Nominal frequency	f_{OSI} CC	–	32.768	–	kHz	
Accuracy	Δf_{OSI} CC	-4	–	4	%	$V_{BAT} = \text{const.}$ $0\text{ }^{\circ}\text{C} \leq T_A \leq 85\text{ }^{\circ}\text{C}$
		-5	–	5	%	$V_{BAT} = \text{const.}$ $T_A < 0\text{ }^{\circ}\text{C}$ or $T_A > 85\text{ }^{\circ}\text{C}$
		-5	–	5	%	$2.4\text{ V} \leq V_{BAT}$, $T_A = 25\text{ }^{\circ}\text{C}$
		-10	–	10	%	$1.95\text{ V} \leq V_{BAT} < 2.4\text{ V}$, $T_A = 25\text{ }^{\circ}\text{C}$
Start-up time	t_{OSIS} CC	–	50	–	μs	

3.3.6 JTAG Interface Timing

The following parameters are applicable for communication through the JTAG debug interface. The JTAG module is fully compliant with IEEE1149.1-2000.

Note: These parameters are not subject to production test, but verified by design and/or characterization.

Note: Operating conditions apply.

Table 42 JTAG Interface Timing Parameters

Parameter	Symbol	Values			Unit	Note / Test Condition
		Min.	Typ.	Max.		
TCK clock period	t_1 SR	25	–	–	ns	
TCK high time	t_2 SR	10	–	–	ns	
TCK low time	t_3 SR	10	–	–	ns	
TCK clock rise time	t_4 SR	–	–	4	ns	
TCK clock fall time	t_5 SR	–	–	4	ns	
TDI/TMS setup to TCK rising edge	t_6 SR	6	–	–	ns	
TDI/TMS hold after TCK rising edge	t_7 SR	6	–	–	ns	
TDO valid after TCK falling edge ¹⁾ (propagation delay)	t_8 CC	–	–	13	ns	$C_L = 50$ pF
		3	–	–	ns	$C_L = 20$ pF
TDO hold after TCK falling edge ¹⁾	t_{18} CC	2	–	–	ns	
TDO high imped. to valid from TCK falling edge ¹⁾²⁾	t_9 CC	–	–	14	ns	$C_L = 50$ pF
TDO valid to high imped. from TCK falling edge ¹⁾	t_{10} CC	–	–	13.5	ns	$C_L = 50$ pF

1) The falling edge on TCK is used to generate the TDO timing.

2) The setup time for TDO is given implicitly by the TCK cycle time.

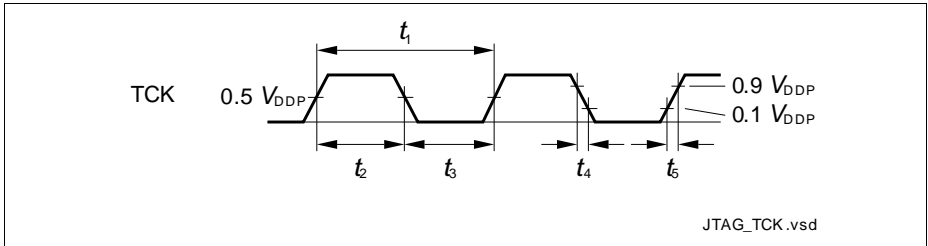

Figure 27 Test Clock Timing (TCK)

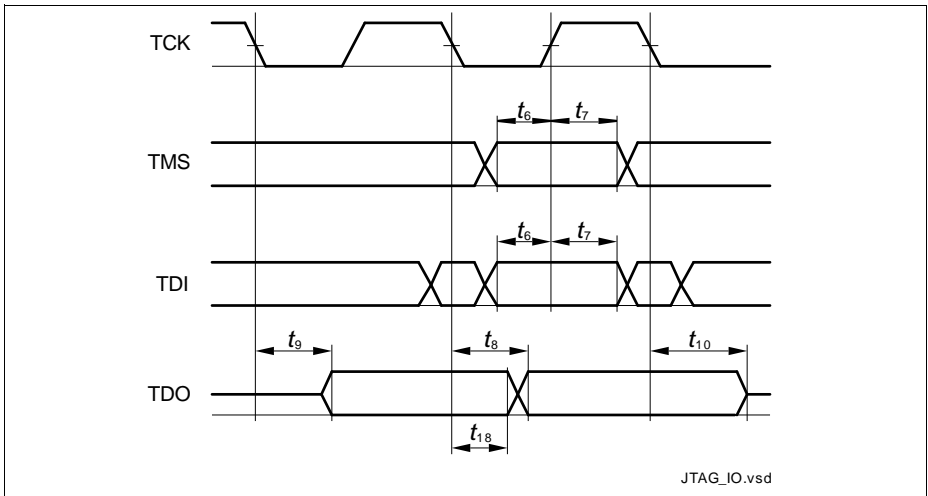

Figure 28 JTAG Timing

3.3.7 Serial Wire Debug Port (SW-DP) Timing

The following parameters are applicable for communication through the SW-DP interface.

Note: These parameters are not subject to production test, but verified by design and/or characterization.

Note: Operating conditions apply.

Table 43 SWD Interface Timing Parameters (Operating Conditions apply)

Parameter	Symbol	SR	Values			Unit	Note / Test Condition
			Min.	Typ.	Max.		
SWDCLK clock period	t_{SC}	SR	25	–	–	ns	$C_L = 30$ pF
			40	–	–	ns	$C_L = 50$ pF
SWDCLK high time	t_1	SR	10	–	500000	ns	
SWDCLK low time	t_2	SR	10	–	500000	ns	
SWDIO input setup to SWDCLK rising edge	t_3	SR	6	–	–	ns	
SWDIO input hold after SWDCLK rising edge	t_4	SR	6	–	–	ns	
SWDIO output valid time after SWDCLK rising edge	t_5	CC	–	–	17	ns	$C_L = 50$ pF
			–	–	13	ns	$C_L = 30$ pF
SWDIO output hold time from SWDCLK rising edge	t_6	CC	3	–	–	ns	

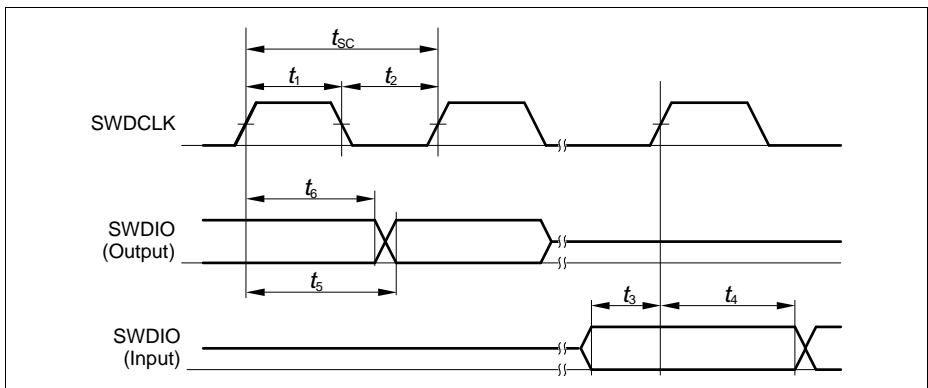

Figure 29 SWD Timing

3.3.8 Embedded Trace Macro Cell (ETM) Timing

The data timing refers to the active clock edge. The XMC4[78]00 ETM uses the half-rate clocking mode. In this mode both, the rising and falling clock edges are active clock edges.

Note: These parameters are not subject to production test, but verified by design and/or characterization.

Note: Operating conditions apply, with $C_L \leq 15$ pF.

Table 44 ETM Interface Timing Parameters

Parameter	Symbol	CC	Values			Unit	Note / Test Condition
			Min.	Typ.	Max.		
TRACECLK period	t_1	CC	13.8	–	–	ns	–
TRACECLK high time	t_2	CC	2	–	–	ns	–
TRACECLK low time	t_3	CC	2	–	–	ns	–
TRACECLK and TRACEDATA rise time	t_4	CC	–	–	3	ns	–
TRACECLK and TRACEDATA fall time	t_5	CC	–	–	3	ns	–
TRACEDATA output valid time	t_6	CC	-2	–	3	ns	–

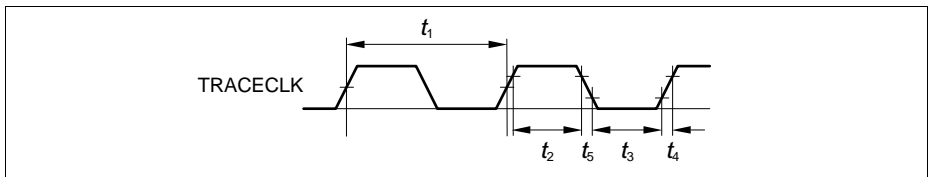

Figure 30 ETM Clock Timing

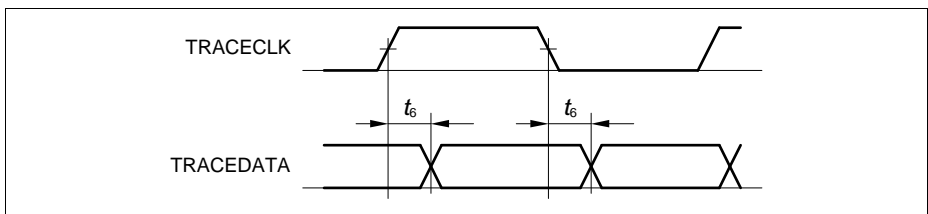

Figure 31 ETM Data Timing

3.3.9 Peripheral Timing

3.3.9.1 Delta-Sigma Demodulator Digital Interface Timing

The following parameters are applicable for the digital interface of the Delta-Sigma Demodulator (DSD).

The data timing is relative to the active clock edge. Depending on the operation mode of the connected modulator that can be the rising and falling clock edge.

Note: These parameters are not subject to production test, but verified by design and/or characterization.

Table 45 DSD Interface Timing Parameters

Parameter	Symbol		Values			Unit	Note / Test Condition
			Min.	Typ.	Max.		
MCLK period in master mode	t_1	CC	33.3	–	–	ns	$t_1 \geq 4 \times t_{\text{PERIPH}}^{1)}$
MCLK high time in master mode	t_2	CC	9	–	–	ns	$t_2 > t_{\text{PERIPH}}^{1)}$
MCLK low time in master mode	t_3	CC	9	–	–	ns	$t_3 > t_{\text{PERIPH}}^{1)}$
MCLK period in slave mode	t_1	SR	33.3	–	–	ns	$t_1 \geq 4 \times t_{\text{PERIPH}}^{1)}$
MCLK high time in slave mode	t_2	SR	t_{PERIPH}	–	–	ns	1)
MCLK low time in slave mode	t_3	SR	t_{PERIPH}	–	–	ns	1)
DIN input setup time to the active clock edge	t_4	SR	$t_{\text{PERIPH}} + 4$	–	–	ns	1)
DIN input hold time from the active clock edge	t_5	SR	$t_{\text{PERIPH}} + 3$	–	–	ns	1)

1) $t_{\text{PERIPH}} = 1 / f_{\text{PERIPH}}$

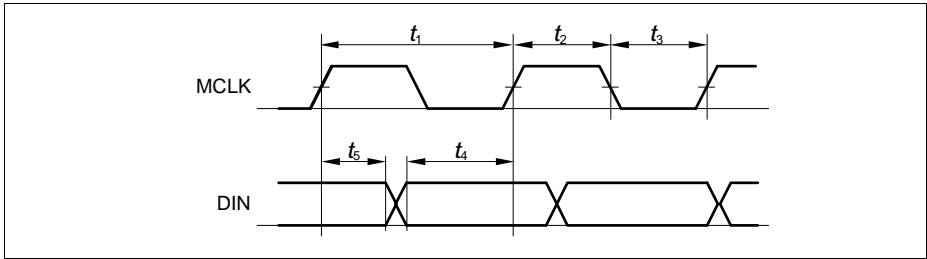

Figure 32 DSD Data Timing

3.3.9.2 Synchronous Serial Interface (USIC SSC) Timing

The following parameters are applicable for a USIC channel operated in SSC mode.

Note: These parameters are not subject to production test, but verified by design and/or characterization.

Table 46 USIC SSC Master Mode Timing

Parameter	Symbol	Values			Unit	Note / Test Condition
		Min.	Typ.	Max.		
SCLKOUT master clock period	t_{CLK} CC	33.3	–	–	ns	
Slave select output SELO active to first SCLKOUT transmit edge	t_1 CC	$t_{PB} - 6.5^{1)}$	–	–	ns	
Slave select output SELO inactive after last SCLKOUT receive edge	t_2 CC	$t_{PB} - 8.5^{1)}$	–	–	ns	
Data output DOUT[3:0] valid time	t_3 CC	-6	–	8	ns	
Receive data input DX0/DX[5:3] setup time to SCLKOUT receive edge	t_4 SR	23	–	–	ns	
Data input DX0/DX[5:3] hold time from SCLKOUT receive edge	t_5 SR	1	–	–	ns	

1) $t_{PB} = 1 / f_{PB}$

Table 47 USIC SSC Slave Mode Timing

Parameter	Symbol		Values			Unit	Note / Test Condition
			Min.	Typ.	Max.		
DX1 slave clock period	t_{CLK}	SR	66.6	–	–	ns	
Select input DX2 setup to first clock input DX1 transmit edge ¹⁾	t_{10}	SR	3	–	–	ns	
Select input DX2 hold after last clock input DX1 receive edge ¹⁾	t_{11}	SR	4	–	–	ns	
Receive data input DX0/DX[5:3] setup time to shift clock receive edge ¹⁾	t_{12}	SR	6	–	–	ns	
Data input DX0/DX[5:3] hold time from clock input DX1 receive edge ¹⁾	t_{13}	SR	4	–	–	ns	
Data output DOUT[3:0] valid time	t_{14}	CC	0	–	24	ns	

1) This input timing is valid for asynchronous input signal handling of slave select input, shift clock input, and receive data input (bits DXnCR.DSEN = 0).

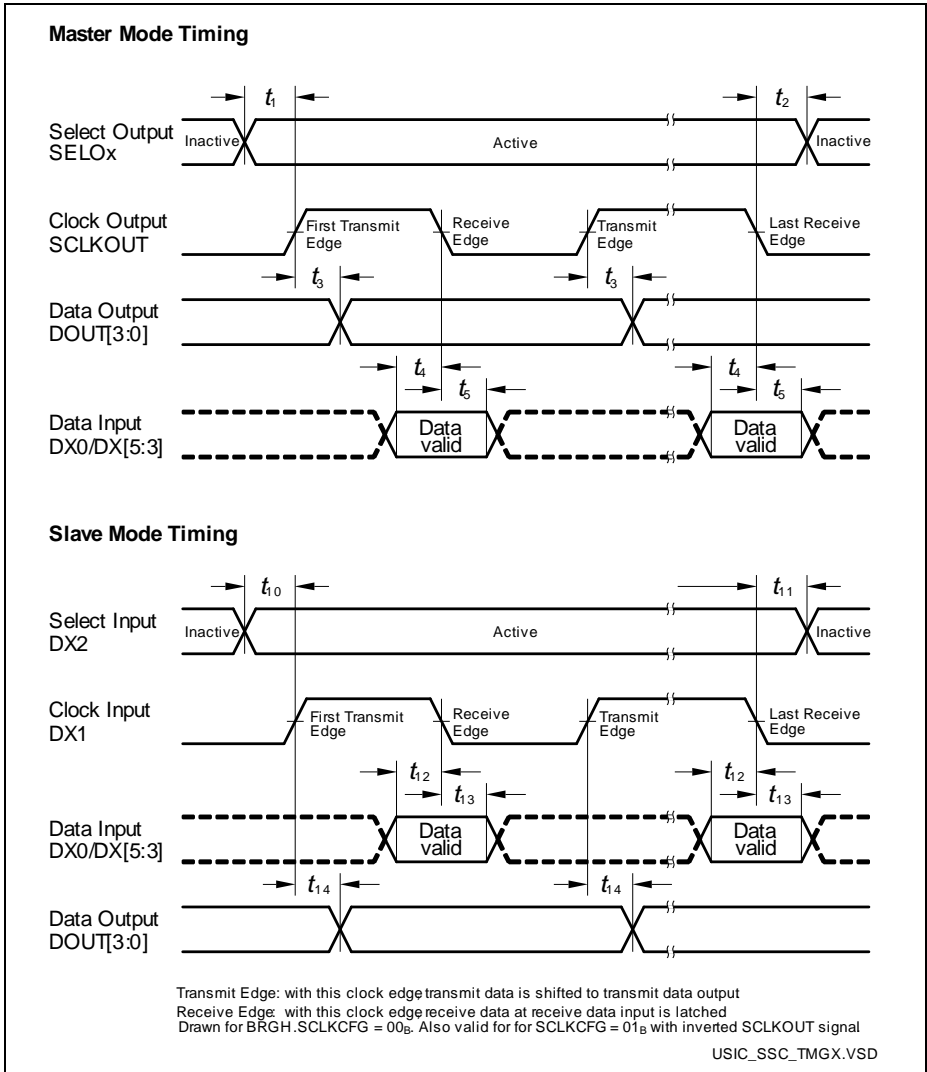

Figure 33 USIC - SSC Master/Slave Mode Timing

Note: This timing diagram shows a standard configuration, for which the slave select signal is low-active, and the serial clock signal is not shifted and not inverted.

3.3.9.3 Inter-IC (IIC) Interface Timing

The following parameters are applicable for a USIC channel operated in IIC mode.

Note: These parameters are not subject to production test, but verified by design and/or characterization.

Table 48 USIC IIC Standard Mode Timing¹⁾

Parameter	Symbol	Values			Unit	Note / Test Condition
		Min.	Typ.	Max.		
Fall time of both SDA and SCL	t_1 CC/SR	-	-	300	ns	
Rise time of both SDA and SCL	t_2 CC/SR	-	-	1000	ns	
Data hold time	t_3 CC/SR	0	-	-	μs	
Data set-up time	t_4 CC/SR	250	-	-	ns	
LOW period of SCL clock	t_5 CC/SR	4.7	-	-	μs	
HIGH period of SCL clock	t_6 CC/SR	4.0	-	-	μs	
Hold time for (repeated) START condition	t_7 CC/SR	4.0	-	-	μs	
Set-up time for repeated START condition	t_8 CC/SR	4.7	-	-	μs	
Set-up time for STOP condition	t_9 CC/SR	4.0	-	-	μs	
Bus free time between a STOP and START condition	t_{10} CC/SR	4.7	-	-	μs	
Capacitive load for each bus line	C_b SR	-	-	400	pF	

1) Due to the wired-AND configuration of an IIC bus system, the port drivers of the SCL and SDA signal lines need to operate in open-drain mode. The high level on these lines must be held by an external pull-up device, approximately 10 kOhm for operation at 100 kbit/s, approximately 2 kOhm for operation at 400 kbit/s.

Table 49 USIC IIC Fast Mode Timing¹⁾

Parameter	Symbol	Values			Unit	Note / Test Condition
		Min.	Typ.	Max.		
Fall time of both SDA and SCL	t_1 CC/SR	20 + 0.1 * C _b 2)	-	300	ns	
Rise time of both SDA and SCL	t_2 CC/SR	20 + 0.1 * C _b 2)	-	300	ns	
Data hold time	t_3 CC/SR	0	-	-	µs	
Data set-up time	t_4 CC/SR	100	-	-	ns	
LOW period of SCL clock	t_5 CC/SR	1.3	-	-	µs	
HIGH period of SCL clock	t_6 CC/SR	0.6	-	-	µs	
Hold time for (repeated) START condition	t_7 CC/SR	0.6	-	-	µs	
Set-up time for repeated START condition	t_8 CC/SR	0.6	-	-	µs	
Set-up time for STOP condition	t_9 CC/SR	0.6	-	-	µs	
Bus free time between a STOP and START condition	t_{10} CC/SR	1.3	-	-	µs	
Capacitive load for each bus line	C _b SR	-	-	400	pF	

1) Due to the wired-AND configuration of an IIC bus system, the port drivers of the SCL and SDA signal lines need to operate in open-drain mode. The high level on these lines must be held by an external pull-up device, approximately 10 kOhm for operation at 100 kbit/s, approximately 2 kOhm for operation at 400 kbit/s.

2) C_b refers to the total capacitance of one bus line in pF.

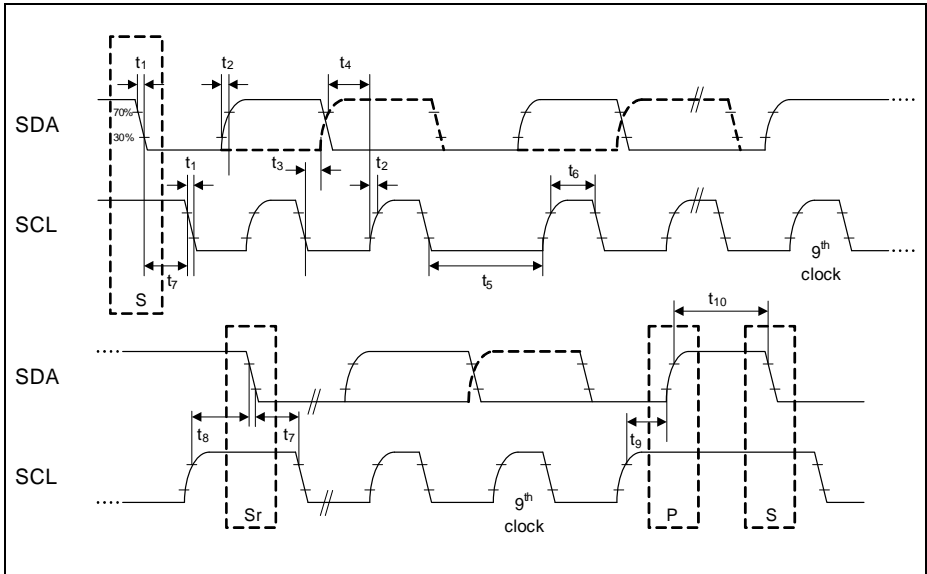

Figure 34 USIC IIC Stand and Fast Mode Timing

3.3.9.4 Inter-IC Sound (IIS) Interface Timing

The following parameters are applicable for a USIC channel operated in IIS mode.

Note: These parameters are not subject to production test, but verified by design and/or characterization.

Table 50 USIC IIS Master Transmitter Timing

Parameter	Symbol	Values			Unit	Note / Test Condition
		Min.	Typ.	Max.		
Clock period	t_1 CC	33.3	–	–	ns	
Clock high time	t_2 CC	0.35 x t_{1min}	–	–	ns	
Clock low time	t_3 CC	0.35 x t_{1min}	–	–	ns	
Hold time	t_4 CC	0	–	–	ns	
Clock rise time	t_5 CC	–	–	0.15 x t_{1min}	ns	

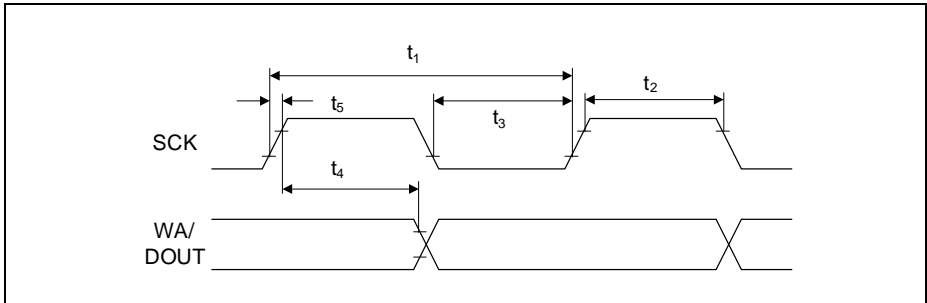

Figure 35 USIC IIS Master Transmitter Timing

Table 51 USIC IIS Slave Receiver Timing

Parameter	Symbol	Values			Unit	Note / Test Condition
		Min.	Typ.	Max.		
Clock period	t_6 SR	66.6	—	—	ns	
Clock high time	t_7 SR	0.35 x t_{6min}	—	—	ns	
Clock low time	t_8 SR	0.35 x t_{6min}	—	—	ns	
Set-up time	t_9 SR	0.2 x t_{6min}	—	—	ns	
Hold time	t_{10} SR	0	—	—	ns	

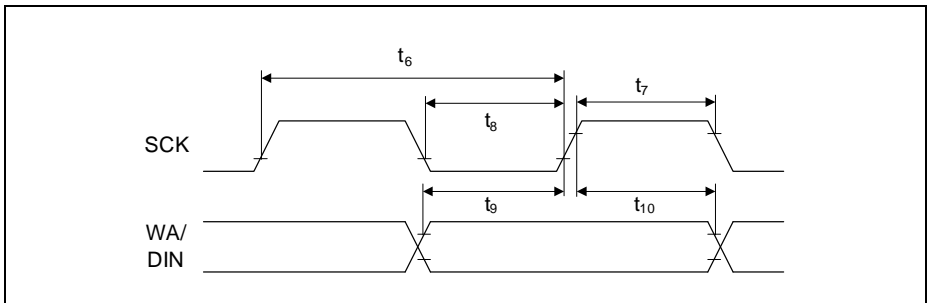

Figure 36 USIC IIS Slave Receiver Timing

3.3.9.5 SDMMC Interface Timing

Note: These parameters are not subject to production test, but verified by design and/or characterization.

Note: Operating Conditions apply, total external capacitive load $C_L = 40$ pF.

AC Timing Specifications (Full-Speed Mode)

Table 52 SDMMC Timing for Full-Speed Mode

Parameter	Symbol	Values	Unit		Note/ Test Condition
			Min.	Max.	
Clock frequency in full speed transfer mode ($1/t_{pp}$)	f_{pp} CC	0	24	MHz	
Clock cycle in full speed transfer mode	t_{pp} CC	40	–	ns	
Clock low time	t_{WL} CC	10	–	ns	
Clock high time	t_{WH} CC	10	–	ns	
Clock rise time	t_{TLH} CC	–	10	ns	
Clock fall time	t_{THL} CC	–	10	ns	
Inputs setup to clock rising edge	t_{ISU_F} SR	2	–	ns	
Inputs hold after clock rising edge	t_{IH_F} SR	2	–	ns	
Outputs valid time in full speed mode	t_{ODLY_F} CC	–	10	ns	
Outputs hold time in full speed mode	t_{OH_F} CC	0	–	ns	

Table 53 SD Card Bus Timing for Full-Speed Mode¹⁾

Parameter	Symbol	Values		Unit	Note/ Test Condition
		Min.	Max.		
SD card input setup time	t_{ISU}	5	–	ns	
SD card input hold time	t_{IH}	5	–	ns	

Table 53 SD Card Bus Timing for Full-Speed Mode¹⁾ (cont'd)

Parameter	Symbol	Values		Unit	Note/ Test Condition
		Min.	Max.		
SD card output valid time	t_{ODLY}	–	14	ns	
SD card output hold time	t_{OH}	0	–	ns	

1) Reference card timing values for calculation examples. Not subject to production test and not characterized.

Full-Speed Output Path (Write)

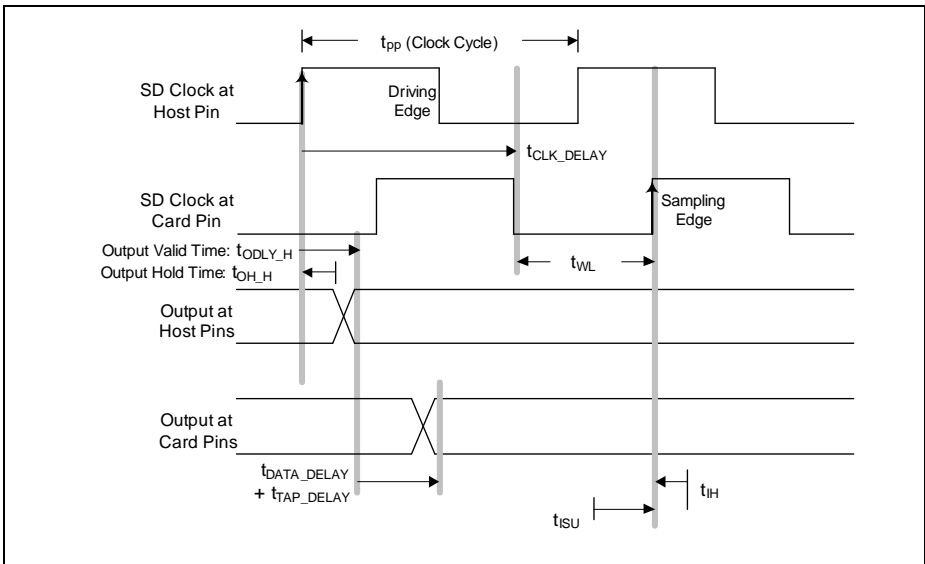

Figure 37 Full-Speed Output Path

Full-Speed Write Meeting Setup (Maximum Delay)

The following equations show how to calculate the allowed skew range between the SD_CLK and SD_DAT/CMD signals on the PCB.

No clock delay:

(1)

$$t_{ODLY_F} + t_{DATA_DELAY} + t_{TAP_DELAY} + t_{ISU} < t_{WL}$$

With clock delay:

$$t_{ODLY_F} + t_{DATA_DELAY} + t_{TAP_DELAY} + t_{ISU} < t_{WL} + t_{CLK_DELAY} \quad (2)$$

$$t_{DATA_DELAY} + t_{TAP_DELAY} + t_{WL} < t_{PP} + t_{CLK_DELAY} - t_{ISU} - t_{ODLY_F} \quad (3)$$

$$t_{DATA_DELAY} + t_{TAP_DELAY} + 20 < 40 + t_{CLK_DELAY} - 5 - 10$$

$$t_{DATA_DELAY} < 5 + t_{CLK_DELAY} - t_{TAP_DELAY}$$

The data can be delayed versus clock up to 5 ns in ideal case of $t_{WL} = 20$ ns.

Full-Speed Write Meeting Hold (Minimum Delay)

The following equations show how to calculate the allowed skew range between the SD_CLK and SD_DAT/CMD signals on the PCB.

$$t_{CLK_DELAY} < t_{WL} + t_{OH_F} + t_{DATA_DELAY} + t_{TAP_DELAY} - t_{IH} \quad (4)$$

$$t_{CLK_DELAY} < 20 + t_{DATA_DELAY} + t_{TAP_DELAY} - 5$$

$$t_{DATA_DELAY} < 15 + t_{CLK_DELAY} + t_{TAP_DELAY}$$

The clock can be delayed versus data up to 18.2 ns (external delay line) in ideal case of $t_{WL} = 20$ ns, with maximum $t_{TAP_DELAY} = 3.2$ ns programmed.

Full-Speed Input Path (Read)

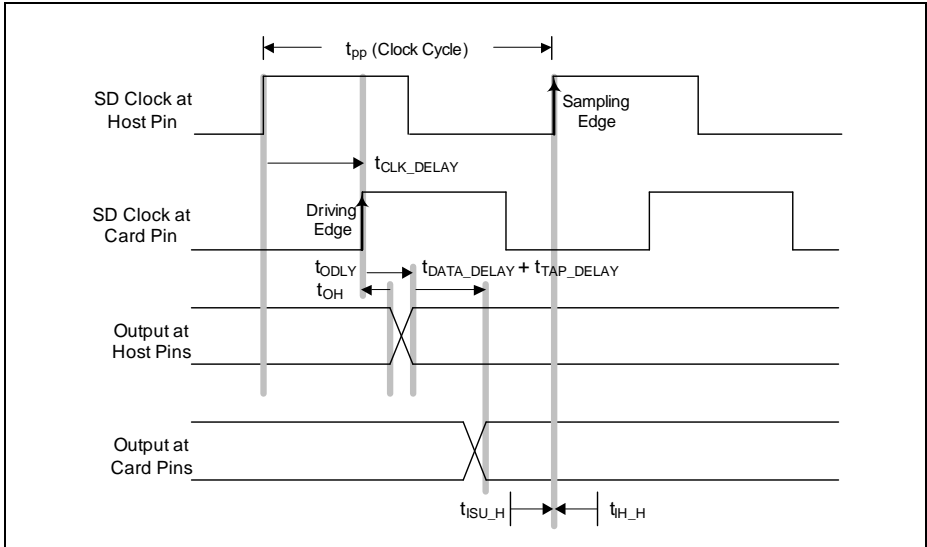

Figure 38 Full-Speed Input Path

Full-Speed Read Meeting Setup (Maximum Delay)

The following equations show how to calculate the allowed combined propagation delay range of the SD_CLK and SD_DAT/CMD signals on the PCB.

(5)

$$t_{CLK_DELAY} + t_{DATA_DELAY} + t_{TAP_DELAY} + t_{ODLY} + t_{ISU_F} < 0,5 \times t_{pp}$$

$$t_{CLK_DELAY} + t_{DATA_DELAY} < 0,5 \times t_{pp} - t_{ODLY} - t_{ISU_F} - t_{TAP_DELAY}$$

$$t_{CLK_DELAY} + t_{DATA_DELAY} < 20 - 14 - 2 - t_{TAP_DELAY}$$

$$t_{CLK_DELAY} + t_{DATA_DELAY} < 4 - t_{TAP_DELAY}$$

The data + clock delay can be up to 4 ns for a 40 ns clock cycle.

Full-Speed Read Meeting Hold (Minimum Delay)

The following equations show how to calculate the allowed combined propagation delay range of the SD_CLK and SD_DAT/CMD signals on the PCB.

(6)

$$t_{\text{CLK_DELAY}} + t_{\text{OH}} + t_{\text{DATA_DELAY}} + t_{\text{TAP_DELAY}} > t_{\text{IH_F}}$$

$$t_{\text{CLK_DELAY}} + t_{\text{DATA_DELAY}} > t_{\text{IH_F}} - t_{\text{OH}} - t_{\text{TAP_DELAY}}$$

$$t_{\text{CLK_DELAY}} + t_{\text{DATA_DELAY}} > 2 - t_{\text{TAP_DELAY}}$$

The data + clock delay must be greater than 2 ns if $t_{\text{TAP_DELAY}}$ is not used.

If the $t_{\text{TAP_DELAY}}$ is programmed to at least 2 ns, the data + clock delay must be greater than 0 ns (or less). This is always fulfilled.

AC Timing Specifications (High-Speed Mode)

Table 54 SDMMC Timing for High-Speed Mode

Parameter	Symbol	Values	Unit		Note/ Test Condition
			Min.	Max.	
Clock frequency in high speed transfer mode ($1/t_{\text{pp}}$)	f_{pp} CC	0	48	MHz	
Clock cycle in high speed transfer mode	t_{pp} CC	20	–	ns	
Clock low time	t_{WL} CC	7	–	ns	
Clock high time	t_{WH} CC	7	–	ns	
Clock rise time	t_{TLH} CC	–	3	ns	
Clock fall time	t_{THL} CC	–	3	ns	
Inputs setup to clock rising edge	$t_{\text{ISU_H}}$ SR	2	–	ns	
Inputs hold after clock rising edge	$t_{\text{IH_H}}$ SR	2	–	ns	
Outputs valid time in high speed mode	$t_{\text{ODLY_H}}$ CC	–	14	ns	
Outputs hold time in high speed mode	$t_{\text{OH_H}}$ CC	2	–	ns	

Table 55 SD Card Bus Timing for High-Speed Mode¹⁾

Parameter	Symbol	Values		Unit	Note/ Test Condition
		Min.	Max.		
SD card input setup time	t_{ISU}	6	–	ns	
SD card input hold time	t_{IH}	2	–	ns	
SD card output valid time	t_{ODLY}	–	14	ns	
SD card output hold time	t_{OH}	2.5	–	ns	

1) Reference card timing values for calculation examples. Not subject to production test and not characterized.

High-Speed Output Path (Write)

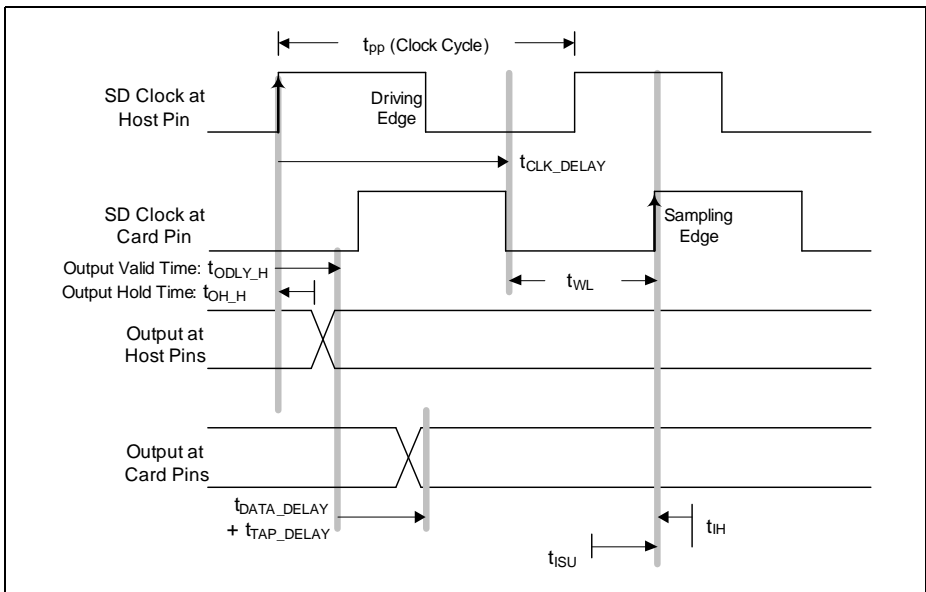

Figure 39 High-Speed Output Path

High-Speed Write Meeting Setup (Maximum Delay)

The following equations show how to calculate the allowed skew between the SD_CLK and SD_DAT/CMD signals on the PCB.

No clock delay:

(7)

$$t_{ODLY_H} + t_{DATA_DELAY} + t_{TAP_DELAY} + t_{ISU} < t_{WL}$$

With clock delay:

(8)

$$t_{ODLY_H} + t_{DATA_DELAY} + t_{TAP_DELAY} + t_{ISU} < t_{WL} + t_{CLK_DELAY}$$

(9)

$$t_{DATA_DELAY} + t_{TAP_DELAY} - t_{CLK_DELAY} < t_{WL} - t_{ISU} - t_{ODLY_H}$$

$$t_{DATA_DELAY} - t_{CLK_DELAY} < t_{WL} - t_{ISU} - t_{ODLY_H} - t_{TAP_DELAY}$$

$$t_{DATA_DELAY} - t_{CLK_DELAY} < 10 - 6 - 14 - t_{TAP_DELAY}$$

$$t_{DATA_DELAY} - t_{CLK_DELAY} < -10 - t_{TAP_DELAY}$$

The data delay is less than the clock delay by at least 10 ns in the ideal case where $t_{WL} = 10$ ns.

High-Speed Write Meeting Hold (Minimum Delay)

The following equations show how to calculate the allowed skew range between the SD_CLK and SD_DAT/CMD signals on the PCB.

(10)

$$t_{CLK_DELAY} < t_{WL} + t_{OH_H} + t_{DATA_DELAY} + t_{TAP_DELAY} - t_{IH}$$

$$t_{CLK_DELAY} - t_{DATA_DELAY} < t_{WL} + t_{OH_H} + t_{TAP_DELAY} - t_{IH}$$

$$t_{CLK_DELAY} - t_{DATA_DELAY} < 10 + 2 + t_{TAP_DELAY} - 2$$

$$t_{CLK_DELAY} - t_{DATA_DELAY} < 10 + t_{TAP_DELAY}$$

The clock can be delayed versus data up to 13.2 ns (external delay line) in ideal case of $t_{WL} = 10$ ns, with maximum $t_{TAP_DELAY} = 3.2$ ns programmed.

High-Speed Input Path (Read)

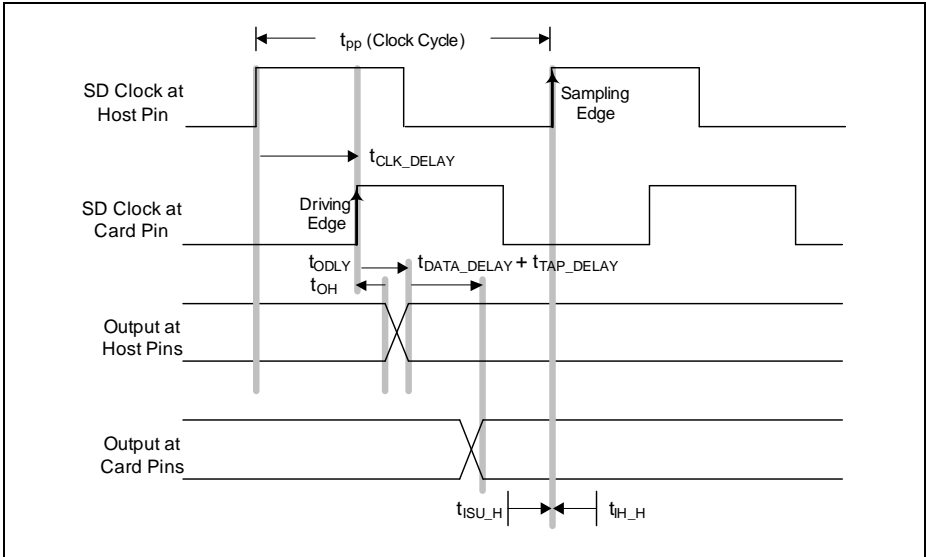

Figure 40 High-Speed Input Path

High-Speed Read Meeting Setup (Maximum Delay)

The following equations show how to calculate the allowed combined propagation delay range of the SD_CLK and SD_DAT/CMD signals on the PCB.

(11)

$$t_{CLK_DELAY} + t_{DATA_DELAY} + t_{TAP_DELAY} + t_{ODLY} + t_{ISU_H} < t_{pp}$$

$$t_{CLK_DELAY} + t_{DATA_DELAY} < t_{pp} - t_{ODLY} - t_{ISU_H} - t_{TAP_DELAY}$$

$$t_{CLK_DELAY} + t_{DATA_DELAY} < 20 - 14 - 2 - t_{TAP_DELAY}$$

$$t_{CLK_DELAY} + t_{DATA_DELAY} < 4 - t_{TAP_DELAY}$$

The data + clock delay can be up to 4 ns for a 20 ns clock cycle.

High-Speed Read Meeting Hold (Minimum Delay)

The following equations show how to calculate the allowed combined propagation delay range of the SD_CLK and SD_DAT/CMD signals on the PCB.

(12)

$$t_{\text{CLK_DELAY}} + t_{\text{OH}} + t_{\text{DATA_DELAY}} + t_{\text{TAP_DELAY}} > t_{\text{IH_H}}$$

$$t_{\text{CLK_DELAY}} + t_{\text{DATA_DELAY}} > t_{\text{IH_H}} - t_{\text{OH}} - t_{\text{TAP_DELAY}}$$

$$t_{\text{CLK_DELAY}} + t_{\text{DATA_DELAY}} > 2 - 2,5 - t_{\text{TAP_DELAY}}$$

$$t_{\text{CLK_DELAY}} + t_{\text{DATA_DELAY}} > -0,5 - t_{\text{TAP_DELAY}}$$

The data + clock delay must be greater than -0.5 ns for a 20 ns clock cycle. This is always fulfilled.

3.3.10 EBU Timing

Note: These parameters are not subject to production test, but verified by design and/or characterization.

Note: Operating Conditions apply, with Class A2 pins and $C_L = 16$ pF.

3.3.10.1 EBU Asynchronous Timing

Note: For each timing, the accumulated PLL jitter must be added separately.

Table 56 Common Timing Parameters for all Asynchronous Timings

Parameter	Sym bol	Limit Values		Unit	Edge Setting	
		Min.	Max.			
Pulse width deviation from the ideal programmed width due to the A2 pad asymmetry, strong driver mode, rise delay - fall delay. $C_L = 16$ pF.	CC	t_a	-1	1.5	ns	sharp
			-2	1		medium
AD(24:16) output delay	CC	t_{13}	-5.5	2	-	-
AD(24:16) output delay	CC	t_{14}	-5.5	2		-

Read Timing

Table 57 Asynchronous Read Timing, Multiplexed and Demultiplexed

Parameter		Symbol	Limit Values		Unit	
			Min.	Max.		
A(24:16) output delay	to \overline{RD} rising edge, deviation from the ideal programmed value.	CC	t_0	-2.5	2.5	ns
A(24:16) output delay		CC	t_1	-2.5	2.5	
\overline{CS} rising edge		CC	t_2	-2	2.5	
\overline{ADV} rising edge		CC	t_3	-1.5	4.5	
\overline{BC} rising edge		CC	t_4	-2.5	2.5	
\overline{WAIT} input setup		SR	t_5	12	–	
\overline{WAIT} input hold		SR	t_6	0	–	
Data input setup		SR	t_7	12	–	
Data input hold		SR	t_8	0	–	
RD / \overline{WR} output delay		CC	t_9	-2.5	1.5	

Multiplexed Read Timing

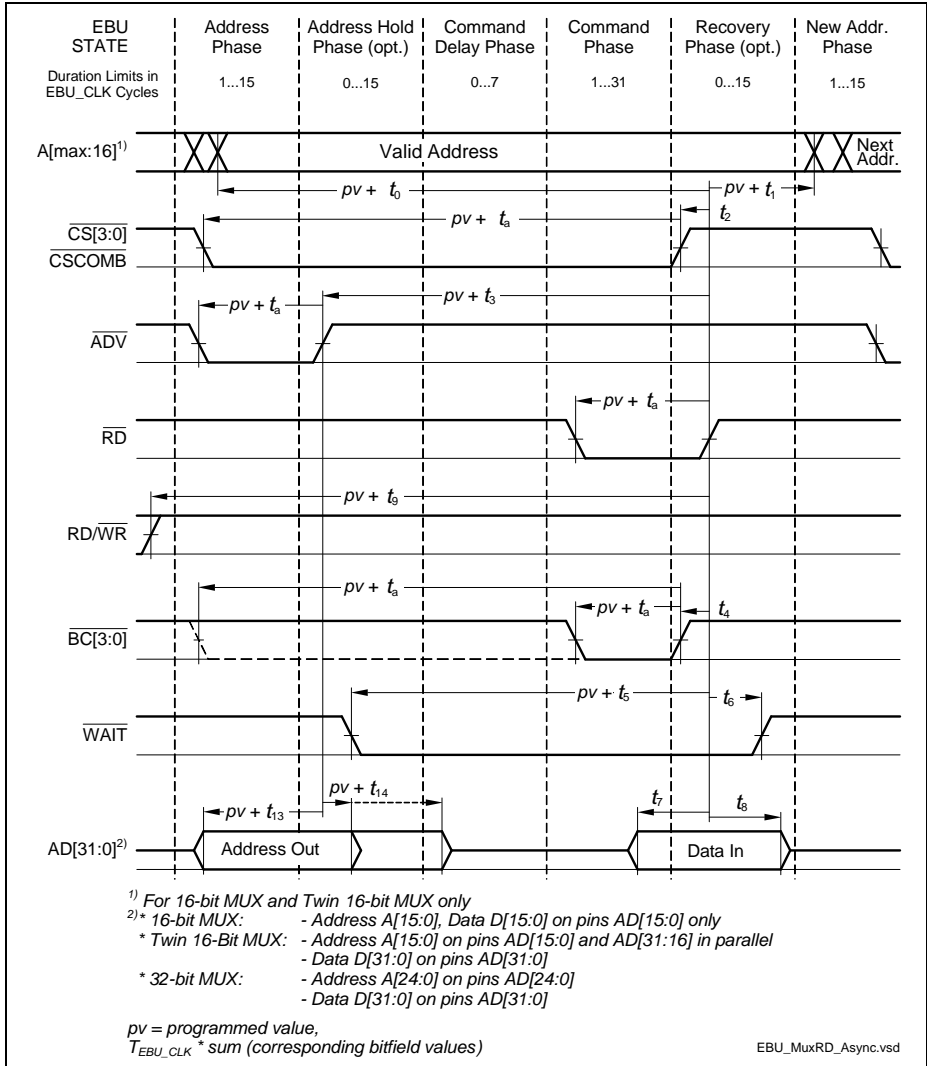

Figure 41 Multiplexed Read Access

Demultiplexed Read Timing

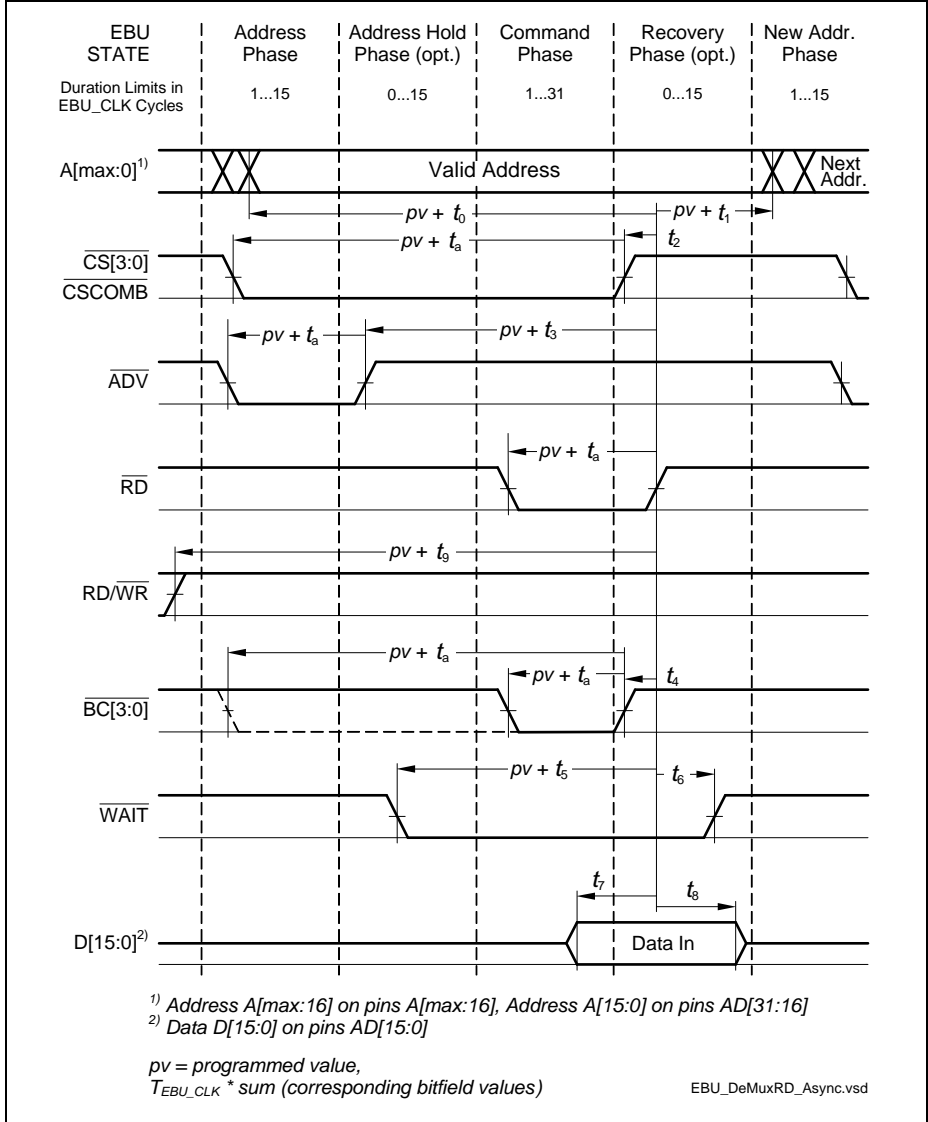

Figure 42 Demultiplexed Read Access

Write Timing

Table 58 Asynchronous Write Timing, Multiplexed and Demultiplexed

Parameter		Symbol	Limit Values		Unit
			Min.	Max.	
A(24:0) output delay	to RD/ $\overline{\text{WR}}$ rising edge, deviation from the ideal programmed value.	CC t_{30}	-2.5	2.5	ns
A(24:0) output delay		CC t_{31}	-2.5	2.5	
$\overline{\text{CS}}$ rising edge		CC t_{32}	-2	2	
$\overline{\text{ADV}}$ rising edge		CC t_{33}	-2	4.5	
$\overline{\text{BC}}$ rising edge		CC t_{34}	-2.5	2	
$\overline{\text{WAIT}}$ input setup		SR t_{35}	12	–	
$\overline{\text{WAIT}}$ input hold		SR t_{36}	0	–	
Data output delay		CC t_{37}	-5.5	2	
Data output delay		CC t_{38}	-5.5	2	
RD / $\overline{\text{WR}}$ output delay		CC t_{39}	-2.5	1.5	

Multiplexed Write Timing

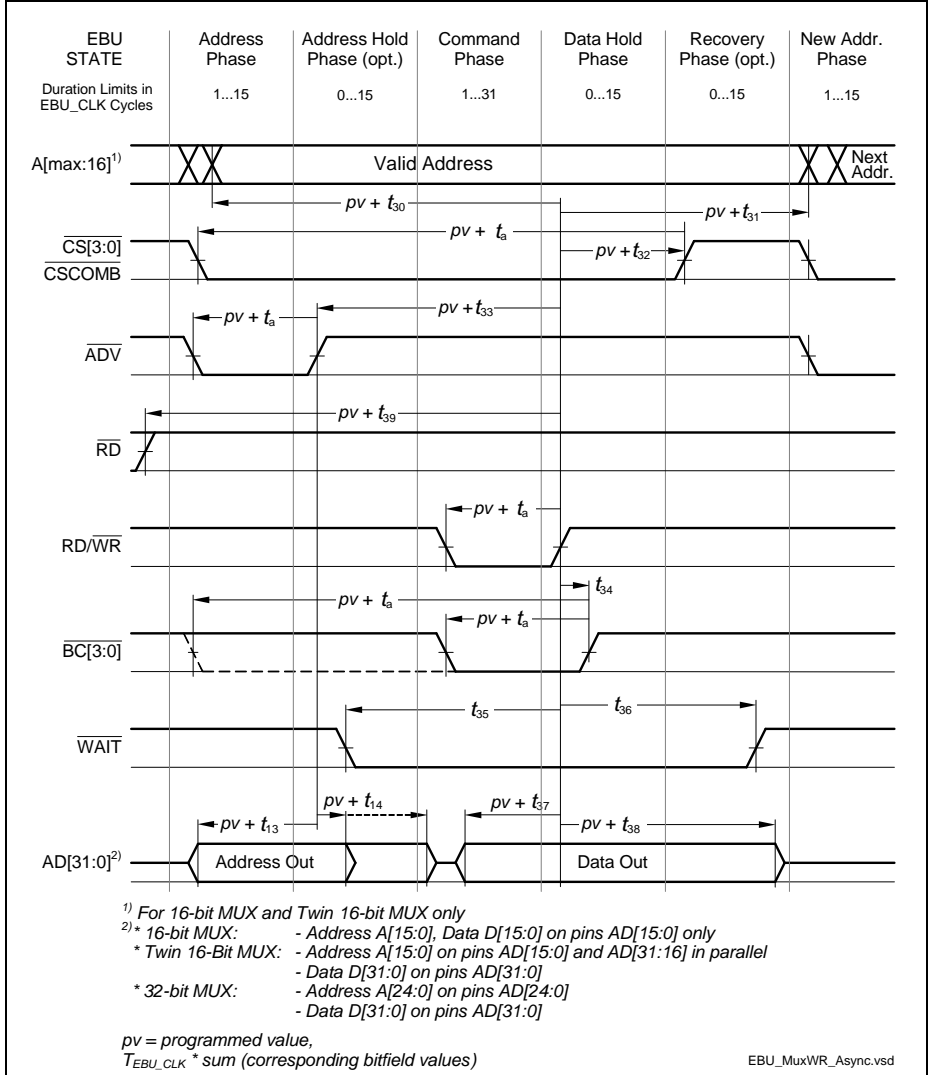

Figure 43 Multiplexed Write Access

Demultiplexed Write Timing

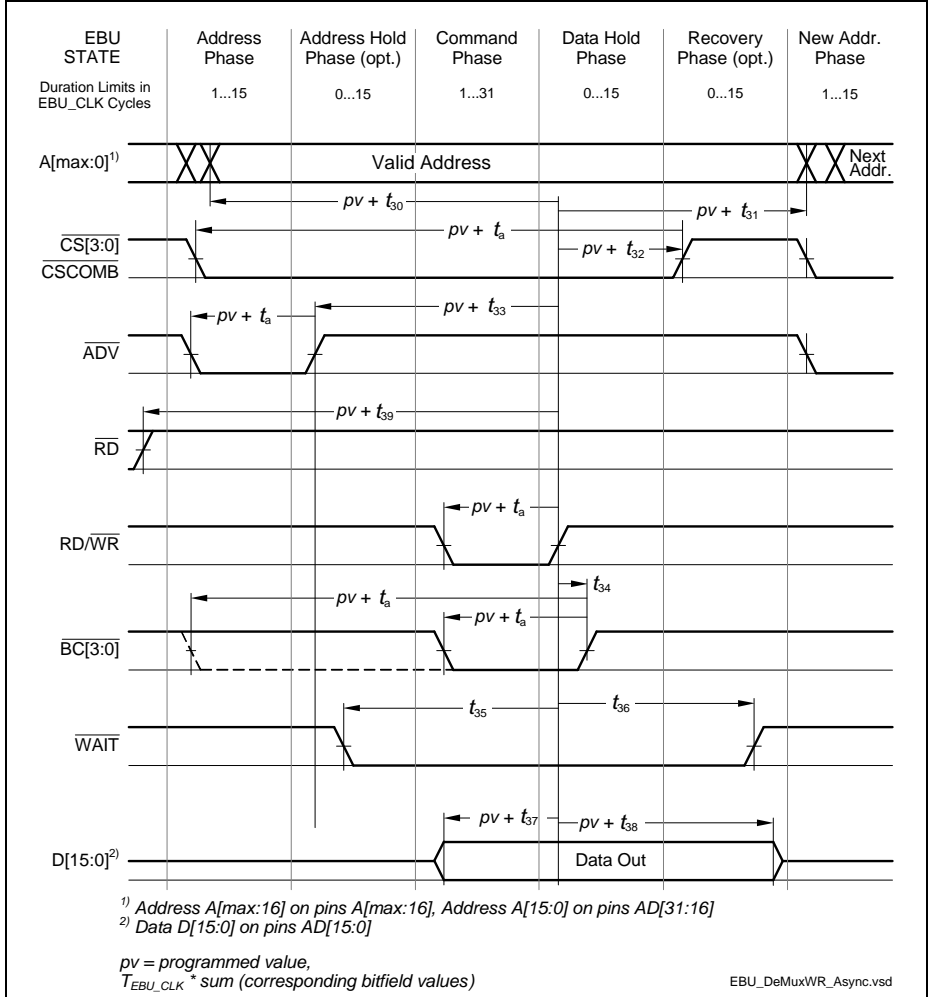

Figure 44 Demultiplexed Write Access

3.3.10.2 EBU Burst Mode Access Timing

Note: These parameters are not subject to production test, but verified by design and/or characterization.

Note: Operating Conditions apply, with Class A2 pins and $C_L = 16 \text{ pF}$.

Table 59 EBU Burst Mode Read / Write Access Timing Parameters

Parameter	Symbol	CC	Values			Unit	Note / Test Condition
			Min.	Typ.	Max.		
Output delay from BFCLKO rising edge	t_{10}	CC	-2	–	2	ns	–
$\overline{\text{RD}}$ and $\overline{\text{RD}}/\overline{\text{WR}}$ active/inactive after BFCLKO active edge ¹⁾	t_{12}	CC	-2	–	2	ns	–
$\overline{\text{CSx}}$ output delay from BFCLKO active edge ¹⁾	t_{21}	CC	-2.5	–	1.5	ns	–
$\overline{\text{ADV}}$ active/inactive after BFCLKO active edge ²⁾	t_{22}	CC	-2	–	2	ns	–
$\overline{\text{BAA}}$ active/inactive after BFCLKO active edge ²⁾	t_{22a}	CC	-2.5	–	1.5	ns	–
Data setup to BFCLKI rising edge ³⁾	t_{23}	SR	3	–	–	ns	–
Data hold from BFCLKI rising edge ³⁾	t_{24}	SR	0	–	–	ns	–
$\overline{\text{WAIT}}$ setup (low or high) to BFCLKI rising edge ³⁾	t_{25}	SR	3	–	–	ns	–
$\overline{\text{WAIT}}$ hold (low or high) from BFCLKI rising edge ³⁾	t_{26}	SR	0	–	–	ns	–

1) An active edge can be a rising or falling edge, depending on the settings of bits BFCON.EBSE / ECSE and the clock divider ratio.

Negative minimum values for these parameters mean that the last data read during a burst may be corrupted. However, with clock feedback enabled, this value is an oversampling not required for the internal bus transaction, and will be discarded.

2) This parameter is valid for BUSCONx.EBSE = 1 and BUSAPx.EXTCLK = 00_B.

For BUSCONx.EBSE = 1 and other values of BUSAPx.EXTCLK, ADV and BAA will be delayed by 1/2 of the internal bus clock period $T_{\text{CPU}} = 1 / f_{\text{CPU}}$.

For BUSCONx. EBSE = 0 and BUSAPx.EXTCLK = 11_B, add 2 internal bus clock periods.

For BUSCONx. EBSE = 0 and other values of BUSAPx.EXTCLK, add 1 internal bus clock period.

Electrical Parameters

3) If the clock feedback is not enabled, the input signals are latched using the internal clock in the same way as for asynchronous access. Thus, t_{5} , t_{6} , t_{7} and t_{8} from the asynchronous timing apply.

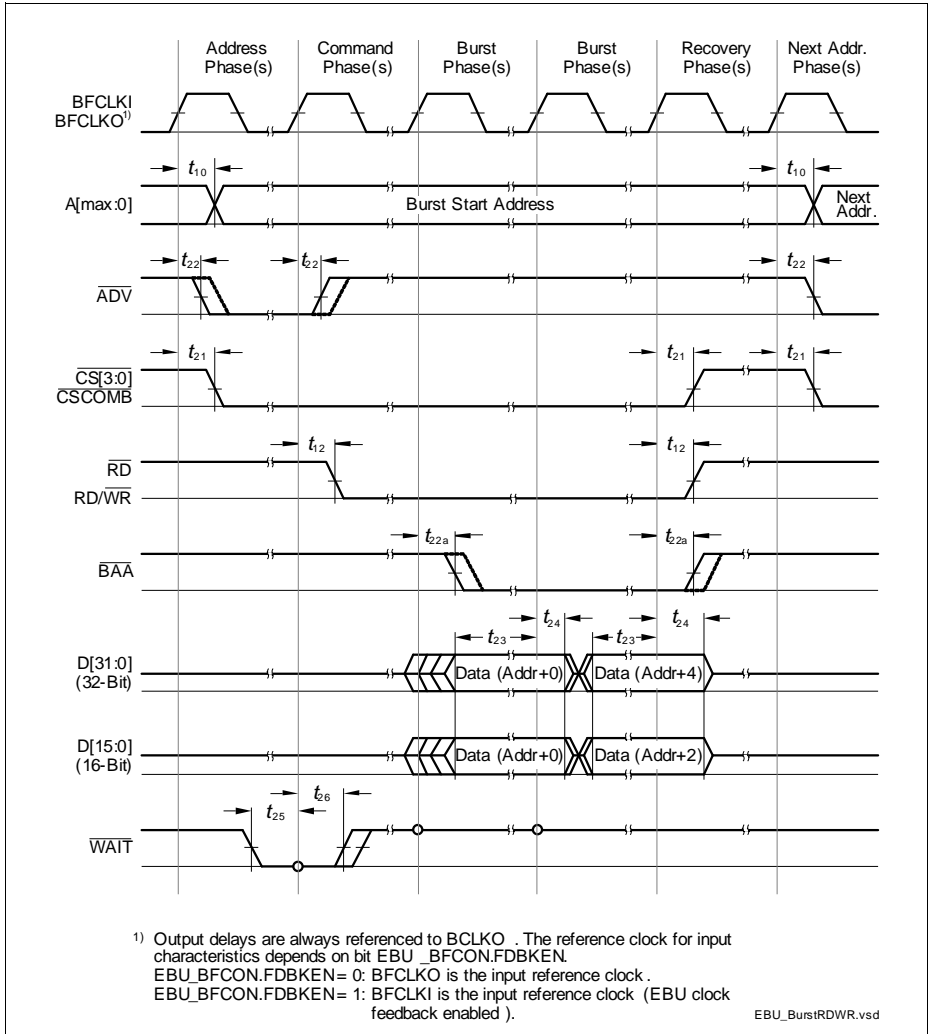

Figure 45 EBU Burst Mode Read / Write Access Timing

3.3.10.3 EBU Arbitration Signal Timing

Note: These parameters are not subject to production test, but verified by design and/or characterization.

Note: Operating Conditions apply.

Table 60 EBU Arbitration Signal Timing Parameters

Parameter	Symbol	Values	Unit			Note / Test Condition
			Min.	Typ.	Max.	
Output delay from BFCLKO rising edge	t_1 CC	–	–	16	ns	$C_L = 50$ pF
Data setup to BFCLKO falling edge	t_2 SR	11	–	–	ns	–
Data hold from BFCLKO falling edge	t_3 SR	2	–	–	ns	–

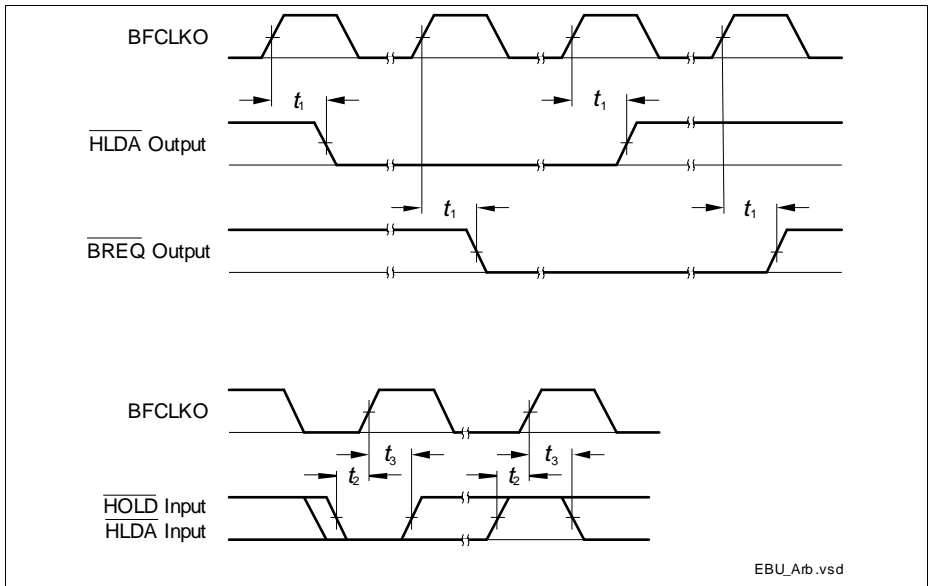

Figure 46 EBU Arbitration Signal Timing

3.3.10.4 EBU SDRAM Access Timing

Note: These parameters are not subject to production test, but verified by design and/or characterization.

Note: Operating Conditions apply, with Class A2 pins and $C_L = 16$ pF.

Note: With $EBU_CLC.SYNC = 1_B$ frequency must be limited to $f_{CPU} = 120$ MHz.

Table 61 EBU SDRAM Access SDCLKO Signal Timing Parameters

Parameter	Symbol	Values			Unit	Note / Test Condition
		Min.	Typ.	Max.		
SDCLKO period	t_1 CC	12.5	–	–	ns	–
SDCLKO high time	t_2 SR	5.5	–	–	ns	–
SDCLKO low time	t_3 SR	3.75	–	–	ns	–
SDCLKO rise time	t_4 SR	–	–	3.0	ns	–
SDCLKO fall time	t_5 SR	–	–	3.0	ns	–

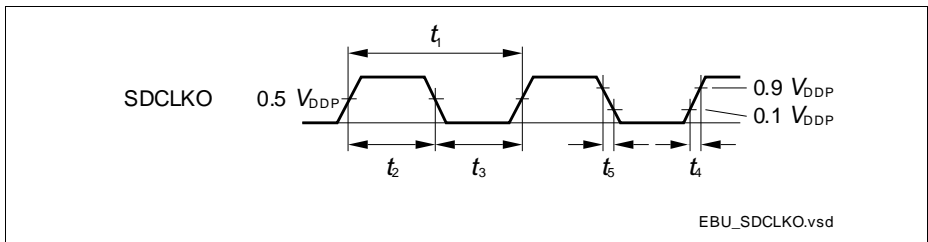

Figure 47 EBU SDRAM Access CLKOUT Timing

Table 62 EBU SDRAM Access Signal Timing Parameters

Parameter		Symbol	Limit Values		Unit
			Min.	Max.	
A(15:0) output valid	from SDCLKO low-to-high transition	CC t_6	–	9	ns
A(15:0) output hold		CC t_7	3	–	
$\overline{\text{CS}}(3:0)$ low		CC t_8	–	9	
$\overline{\text{CS}}(3:0)$ high		CC t_9	3	–	
$\overline{\text{RAS}}$ low		CC t_{10}	–	9	
$\overline{\text{RAS}}$ high		SR t_{11}	3	–	
$\overline{\text{CAS}}$ low		SR t_{12}	–	9	
$\overline{\text{CAS}}$ high		CC t_{13}	3	–	
$\overline{\text{RD}}/\overline{\text{WR}}$ low		CC t_{14}	–	9	
$\overline{\text{RD}}/\overline{\text{WR}}$ high		CC t_{15}	3	–	
$\overline{\text{BC}}(3:0)$ low		CC t_{16}	–	9	
$\overline{\text{BC}}(3:0)$ high		CC t_{17}	3	–	
D(15:0) output valid		CC t_{18}	–	9	
D(15:0) output hold		CC t_{19}	3	–	
CKE output valid ¹⁾		CC t_{22}	–	7	
CKE output hold ¹⁾		CC t_{23}	2	–	
D(15:0) input hold		SR t_{21}	3	–	
D(15:0) input setup to SDCLKO low-to-high transition	SR t_{20}	4	–		

1) Not depicted in the read and write access timing figures below.

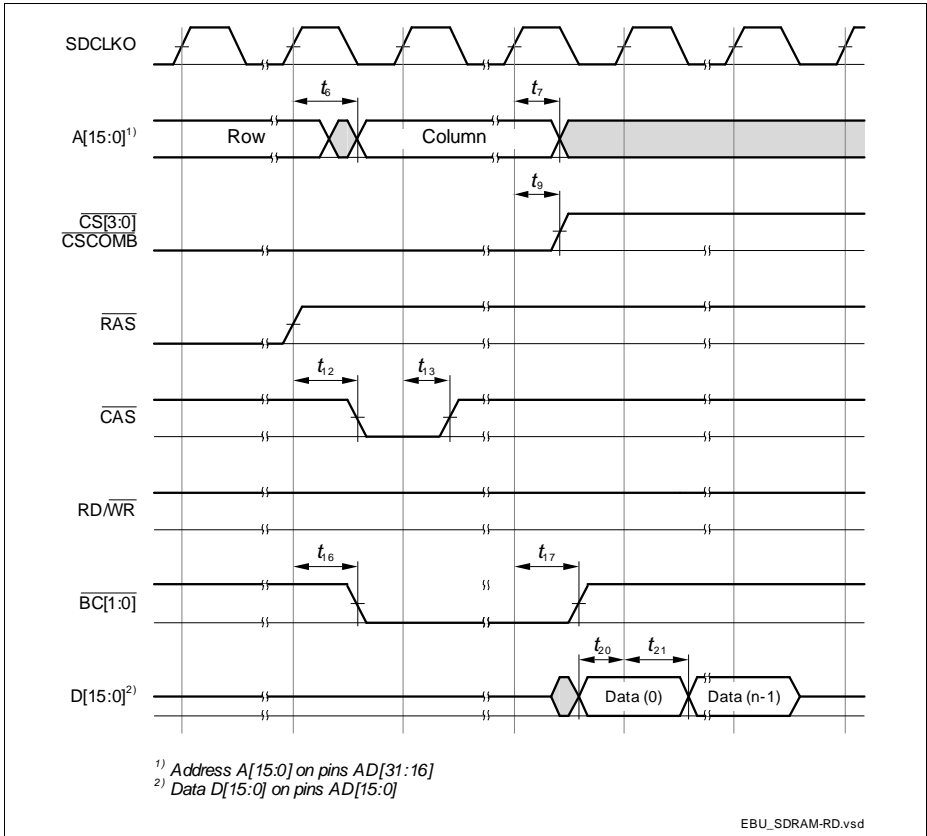

Figure 48 EBU SDRAM Read Access Timing

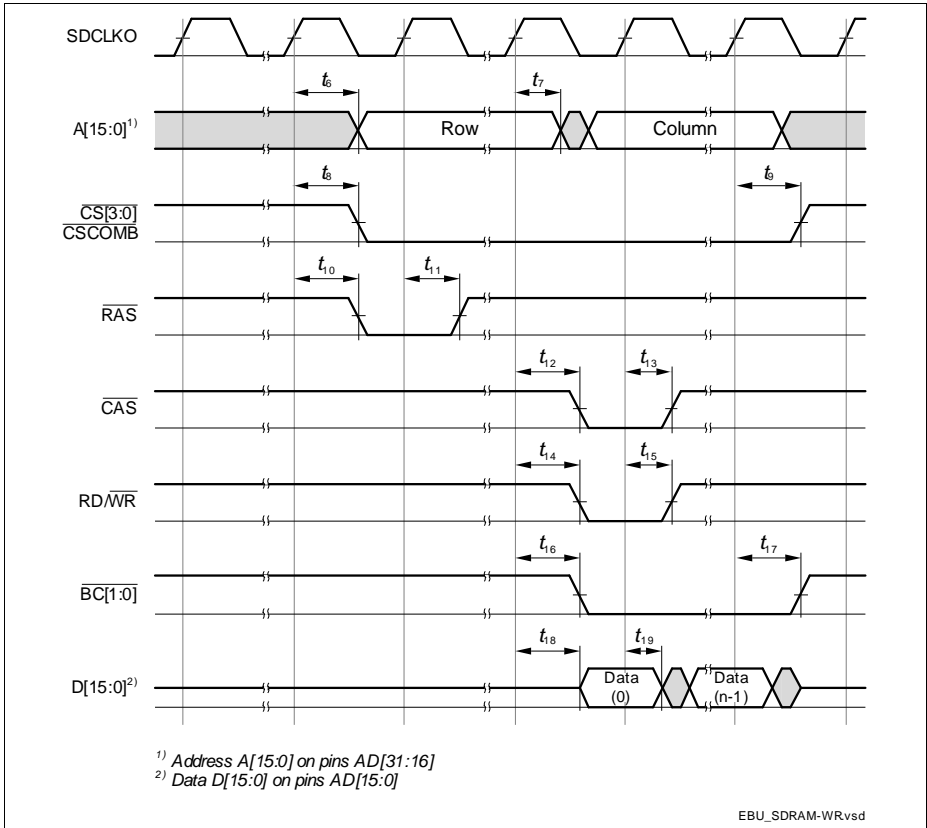

Figure 49 EBU SDRAM Write Access Timing

3.3.11 USB Interface Characteristics

The Universal Serial Bus (USB) Interface is compliant to the USB Rev. 2.0 Specification and the OTG Specification Rev. 1.3. High-Speed Mode is not supported.

Note: These parameters are not subject to production test, but verified by design and/or characterization.

Table 63 USB Timing Parameters (operating conditions apply)

Parameter	Symbol		Values			Unit	Note / Test Condition
			Min.	Typ.	Max.		
Rise time	t_R	CC	4	–	20	ns	$C_L = 50 \text{ pF}$
Fall time	t_F	CC	4	–	20	ns	$C_L = 50 \text{ pF}$
Rise/Fall time matching	t_R/t_F	CC	90	–	111.11	%	$C_L = 50 \text{ pF}$
Crossover voltage	V_{CRS}	CC	1.3	–	2.0	V	$C_L = 50 \text{ pF}$

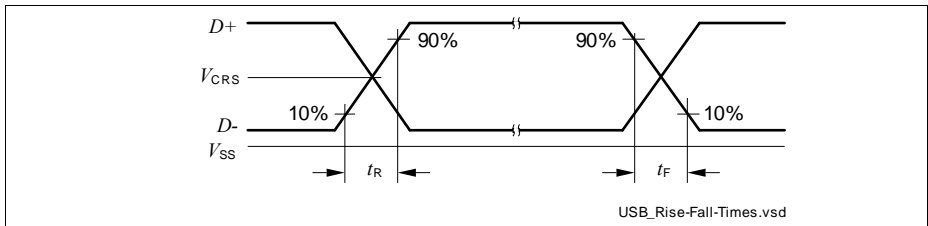

Figure 50 USB Signal Timing

3.3.12 Ethernet Interface (ETH) Characteristics

For proper operation of the Ethernet Interface it is required that $f_{SYS} \geq 100$ MHz.

Note: These parameters are not subject to production test, but verified by design and/or characterization.

3.3.12.1 ETH Measurement Reference Points

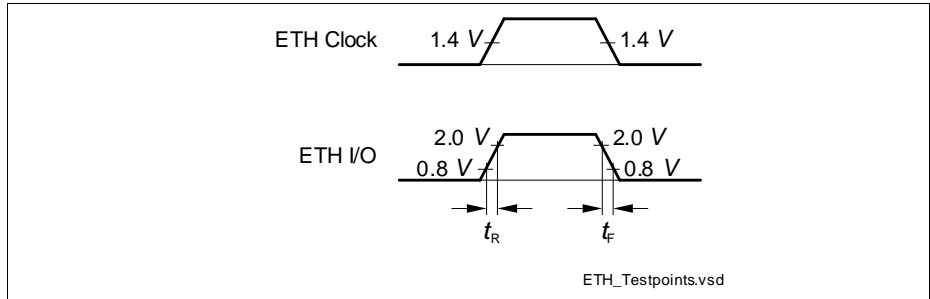

Figure 51 ETH Measurement Reference Points

3.3.12.2 ETH Management Signal Parameters (ETH_MDC, ETH_MDIO)

Table 64 ETH Management Signal Timing Parameters

Parameter	Symbol		Values			Unit	Note / Test Condition
			Min.	Typ.	Max.		
ETH_MDC period	t_1	CC	400	–	–	ns	$C_L = 25 \text{ pF}$
ETH_MDC high time	t_2	CC	160	–	–	ns	
ETH_MDC low time	t_3	CC	160	–	–	ns	
ETH_MDIO setup time (output)	t_4	CC	10	–	–	ns	
ETH_MDIO hold time (output)	t_5	CC	10	–	–	ns	
ETH_MDIO data valid (input)	t_6	SR	0	–	300	ns	

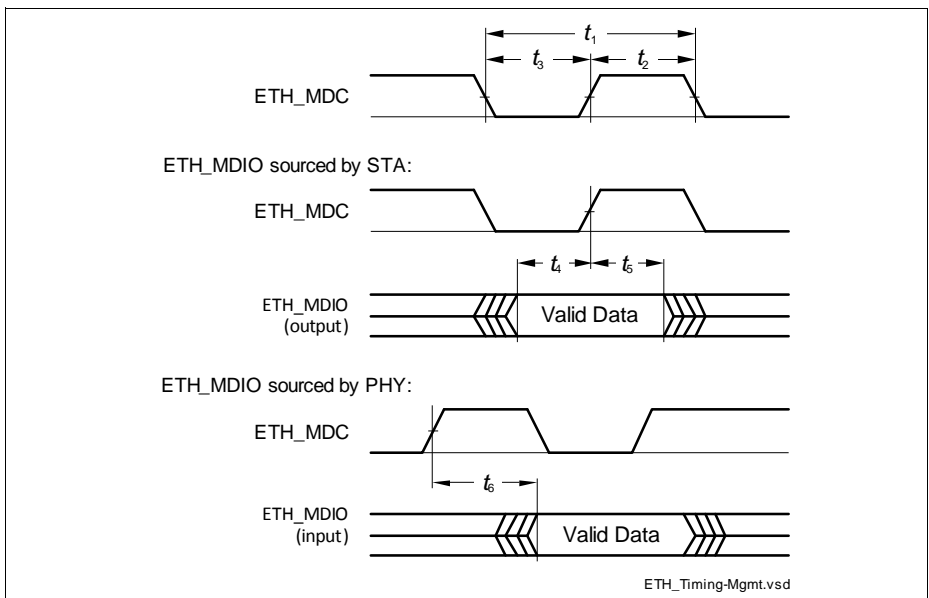

Figure 52 ETH Management Signal Timing

3.3.12.3 ETH MII Parameters

In the following, the parameters of the MII (Media Independent Interface) are described.

Table 65 ETH MII Signal Timing Parameters

Parameter	Symbol	SR	Values			Unit	Note / Test Condition
			Min.	Typ.	Max.		
Clock period, 10 Mbps	t_7	SR	400	–	–	ns	$C_L = 25 \text{ pF}$
Clock high time, 10 Mbps	t_8	SR	140	–	260	ns	
Clock low time, 10 Mbps	t_9	SR	140	–	260	ns	
Clock period, 100 Mbps	t_7	SR	40	–	–	ns	
Clock high time, 100 Mbps	t_8	SR	14	–	26	ns	
Clock low time, 100 Mbps	t_9	SR	14	–	26	ns	
Input setup time	t_{10}	SR	10	–	–	ns	
Input hold time	t_{11}	SR	10	–	–	ns	
Output valid time	t_{12}	CC	0	–	25	ns	

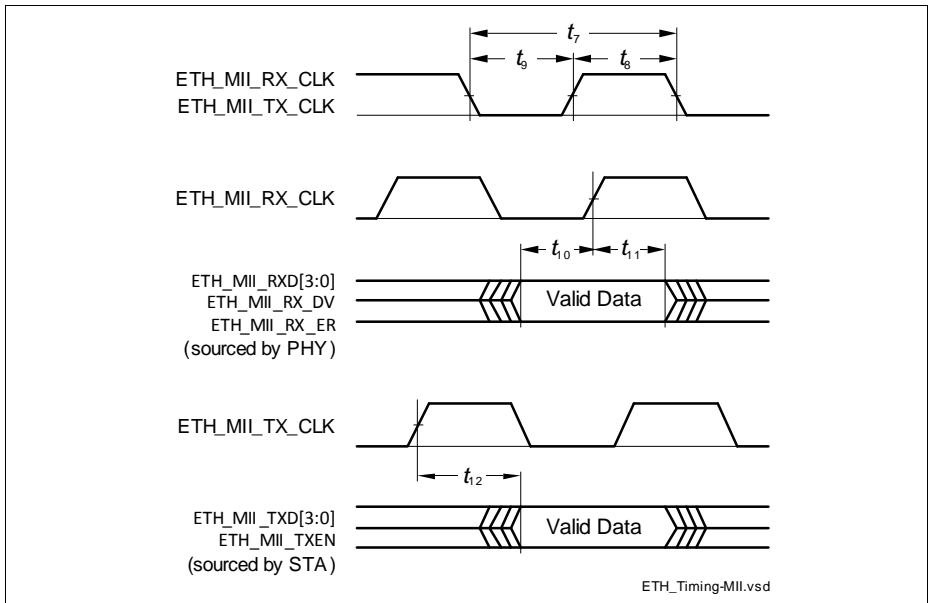

Figure 53 ETH MII Signal Timing

3.3.12.4 ETH RMII Parameters

In the following, the parameters of the RMII (Reduced Media Independent Interface) are described.

Table 66 ETH RMII Signal Timing Parameters

Parameter	Symbol		Values			Unit	Note / Test Condition
			Min.	Typ.	Max.		
ETH_RMII_REF_CL clock period	t_{13}	SR	20	–	–	ns	$C_L = 25 \text{ pF}$; 50 ppm
ETH_RMII_REF_CL clock high time	t_{14}	SR	7	–	13	ns	$C_L = 25 \text{ pF}$
ETH_RMII_REF_CL clock low time	t_{15}	SR	7	–	13	ns	
ETH_RMII_RXD[1:0], ETH_RMII_CRS setup time	t_{16}	SR	4	–	–	ns	
ETH_RMII_RXD[1:0], ETH_RMII_CRS hold time	t_{17}	SR	2	–	–	ns	
ETH_RMII_TXD[1:0], ETH_RMII_TXEN data valid	t_{18}	CC	4	–	15	ns	

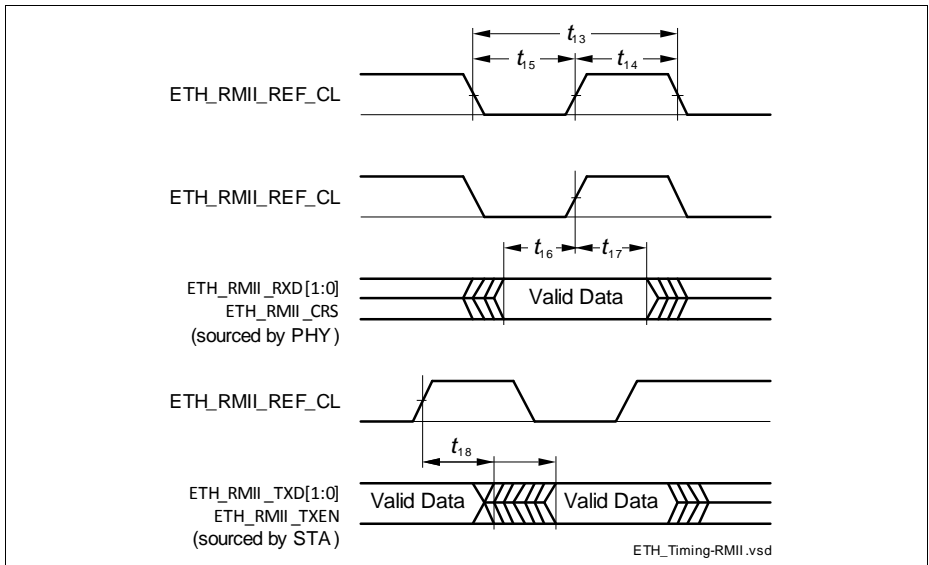

Figure 54 ETH RMII Signal Timing

3.3.13 EtherCAT (ECAT) Characteristics

3.3.13.1 ECAT Measurement Reference Points

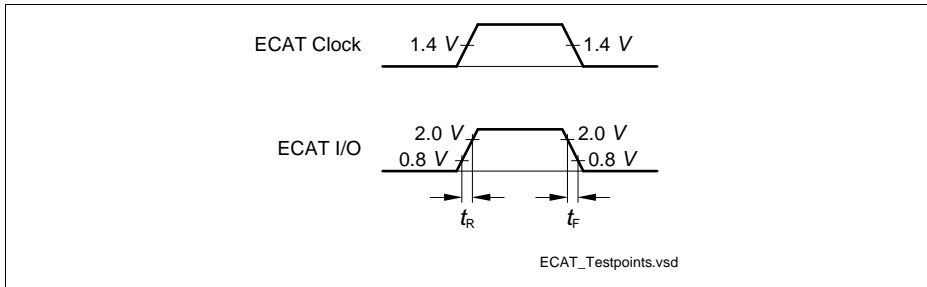

Figure 55 Measurement Reference Points

3.3.13.2 ETH Management Signal Parameters (MCLK, MDIO)

Table 67 ECAT Management Signal Timing Parameters

Parameter	Symbol	Values			Unit	Note / Test Condition
		Min.	Typ.	Max.		
ECAT_MCLK period	t_{MCLK} CC	–	400	–	ns	IEEE802.3 requirement (2.5 MHz) $C_L = 25 \text{ pF}$
ECAT_MCLK high time	t_{MCLK_h} CC	160	–	–	ns	
ECAT_MCLK low time	t_{MCLK_l} CC	160	–	–	ns	
ECAT_MDIO setup time (output)	$t_{\text{D}_\text{setup}}$ CC	10	–	–	ns	
ECAT_MDIO hold time (output)	t_{D_hold} CC	10	–	–	ns	
ECAT_MDIO data valid (input)	$t_{\text{D}_\text{valid}}$ SR	0	–	300	ns	

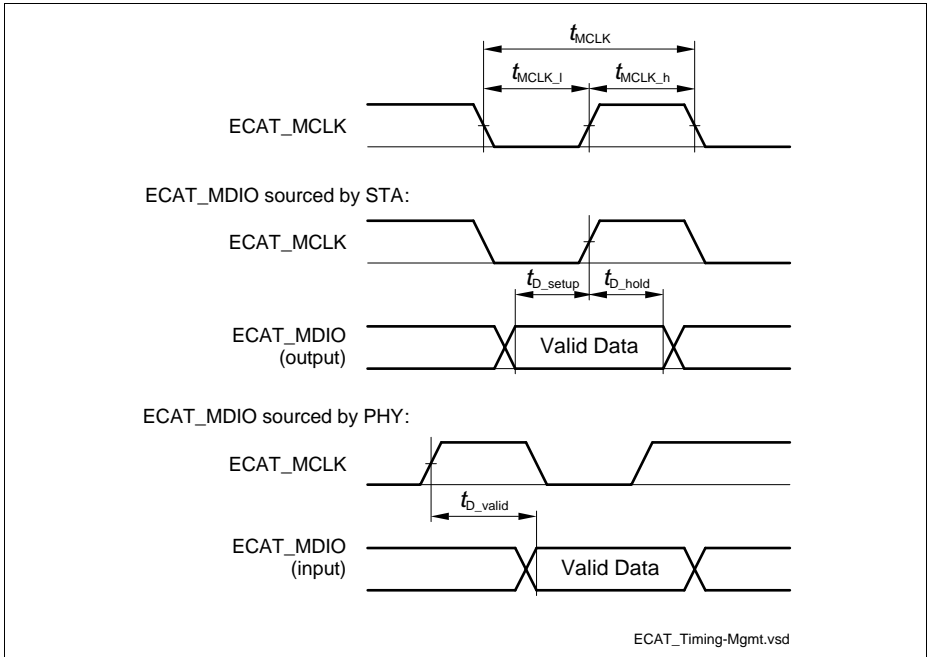

Figure 56 ECAT Management Signal Timing

3.3.13.3 MII Timing TX Characteristics

Table 68 ETH MII TX Signal Timing Parameters

Parameter	Symbol	Values			Unit	Note / Test Condition
		Min.	Typ.	Max.		
PHY_CLK25, TX_CLK period	t_{TX_CLK} SR	–	40	–	ns	
Delay between PHY clock source PHY_CLK25 and TX_CLK output of the PHY	t_{PHY_delay} SR	–	–	–	ns	PHY dependent

Table 68 ETH MII TX Signal Timing Parameters (cont'd)

Parameter	Symbol	Values			Unit	Note / Test Condition
		Min.	Typ.	Max.		
PHY setup requirement: TXEN/TXD[3:0] with respect to TX_CLK	t_{TX_setup} SR	15	–	0	ns	PHY dependent IEEE802.3 limit is 15 ns
PHY hold requirement: TXEN/TXD[3:0] with respect to TX_CLK	t_{TX_hold} CC	0	–	25	ns	PHY dependent IEEE802.3 limit is 0 ns

Note: ECAT0_CONPx.TX_SHIFT can be adjusted by displaying TX_CLK of a PHY and TXEN/TXD[3:0] on an oscilloscope. TXEN/TXD[3:0] is allowed to change between 0 ns and 25 ns after a rising edge of TX_CLK (according to IEEE802.3 – check your PHY’s documentation). Configure TX_SHIFT so that TXEN/TXD[3:0] change near the middle of this range. It is sufficient to check just one of the TXEN/TXD[3:0] signals, because they are nearly generated at the same time.

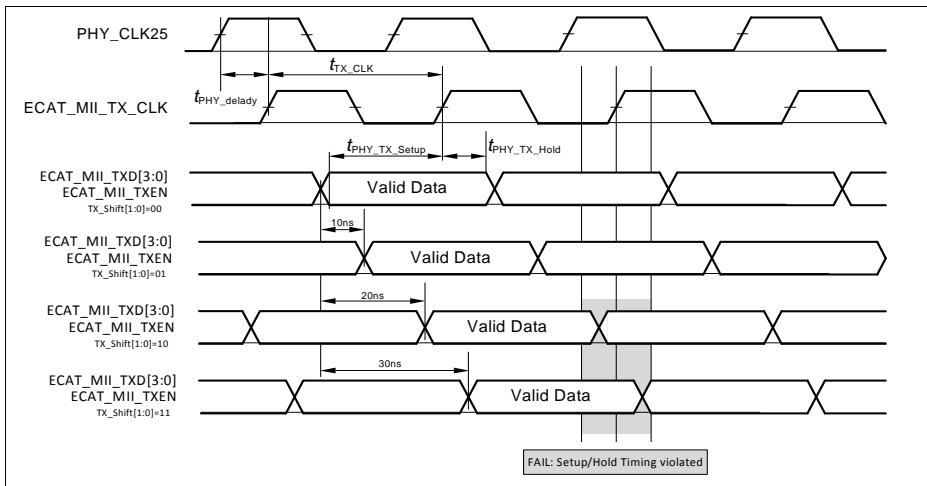

Figure 57 MII TX Characteristics

3.3.13.4 MII Timing RX Characteristics

Table 69 ETH MII RX Signal Timing Parameters

Parameter	Symbol	Values			Unit	Note / Test Condition
		Min.	Typ.	Max.		
RX_CLK period	t_{RX_CLK} SR	–	40	–	ns	$C_L = 25\text{ pF}$, IEEE802.3 requirement
RX_DV/RX_DV/RXD[3:0] valid before rising edge of RX_CLK	t_{RX_setup} SR	10	–	–	ns	
RX_DV/RX_DV/RXD[3:0] valid after rising edge of RX_CLK	t_{RX_hold} SR	10	–	–	ns	

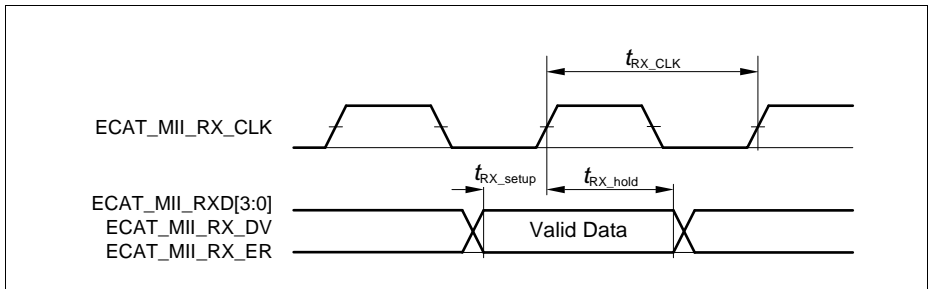

Figure 58 MII RX characteristics

3.3.13.5 Sync/Latch Timings

Table 70 Sync/Latch Timings

Parameter	Symbol	Values			Unit	Note / Test Condition
		Min.	Typ.	Max.		
SYNC0/1	$t_{DC_SYNC_Jitter}$ SR	–	–	11 + m ¹⁾	ns	
LATCH0/1	t_{DC_LATCH} SR	12 + n ²⁾	–	–	ns	

- 1) additional delay form logic and pad, number is added after characterization
- 2) additional shaping delay, number is added after characterization

Note: SYNC0/1 pulse length are initially loaded by EEPROM content ADR 0x0002. The actual used value can be read back from Register DC_PULSE_LEN.

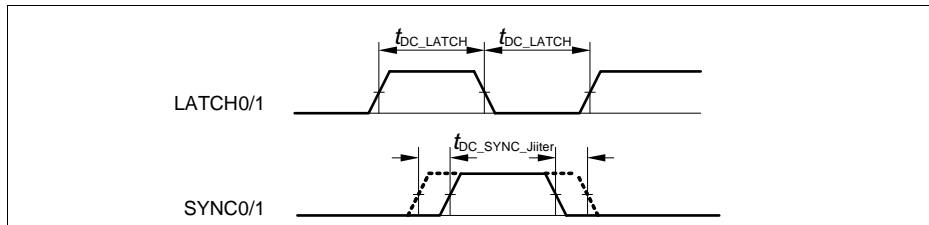

Figure 59 Sync/Latch Timings

4 Package and Reliability

The XMC4[78]00 is a member of the XMC4000 Family of microcontrollers. It is also compatible to a certain extent with members of similar families or subfamilies.

Each package is optimized for the device it houses. Therefore, there may be slight differences between packages of the same pin-count but for different device types. In particular, the size of the Exposed Die Pad may vary.

If different device types are considered or planned for an application, it must be ensured that the board layout fits all packages under consideration.

4.1 Package Parameters

Table 71 provides the thermal characteristics of the packages used in XMC4[78]00.

Table 71 Thermal Characteristics of the Packages

Parameter	Symbol	Limit Values		Unit	Package Types
		Min.	Max.		
Exposed Die Pad dimensions including U-Groove	Ex × Ey CC	-	7.0 × 7.0	mm	PG-LQFP-144-24
		-	7.0 × 7.0	mm	PG-LQFP-100-25
Exposed Die Pad dimensions excluding U-Groove	Ax × Ay CC	-	6.2 × 6.2	mm	PG-LQFP-144-24
		-	6.2 × 6.2	mm	PG-LQFP-100-25
Thermal resistance Junction-Ambient $T_J \leq 150\text{ °C}$	$R_{\theta JA}$ CC	-	27.0	K/W	PG-LFBGA-196-2
		-	19.5	K/W	PG-LQFP-144-24 ¹⁾
		-	22.5	K/W	PG-LQFP-100-25 ¹⁾

1) Device mounted on a 4-layer JEDEC board (JESD 51-7) with thermal vias; exposed pad soldered.

Note: For electrical reasons, it is required to connect the exposed pad to the board ground V_{SS} , independent of EMC and thermal requirements.

4.1.1 Thermal Considerations

When operating the XMC4[78]00 in a system, the total heat generated in the chip must be dissipated to the ambient environment to prevent overheating and the resulting thermal damage.

The maximum heat that can be dissipated depends on the package and its integration into the target board. The “Thermal resistance $R_{\theta JA}$ ” quantifies these parameters. The power dissipation must be limited so that the average junction temperature does not exceed 150 °C.

The difference between junction temperature and ambient temperature is determined by

$$\Delta T = (P_{\text{INT}} + P_{\text{IOSTAT}} + P_{\text{IODYN}}) \times R_{\Theta\text{JA}}$$

The internal power consumption is defined as

$$P_{\text{INT}} = V_{\text{DDP}} \times I_{\text{DDP}} \text{ (switching current and leakage current).}$$

The static external power consumption caused by the output drivers is defined as

$$P_{\text{IOSTAT}} = \Sigma((V_{\text{DDP}} - V_{\text{OH}}) \times I_{\text{OH}}) + \Sigma(V_{\text{OL}} \times I_{\text{OL}})$$

The dynamic external power consumption caused by the output drivers (P_{IODYN}) depends on the capacitive load connected to the respective pins and their switching frequencies.

If the total power dissipation for a given system configuration exceeds the defined limit, countermeasures must be taken to ensure proper system operation:

- Reduce V_{DDP} , if possible in the system
- Reduce the system frequency
- Reduce the number of output pins
- Reduce the load on active output drivers

4.2 Package Outlines

The availability of different packages for different devices types is listed in [Table 1](#).

The exposed die pad dimensions are listed in [Table 71](#).

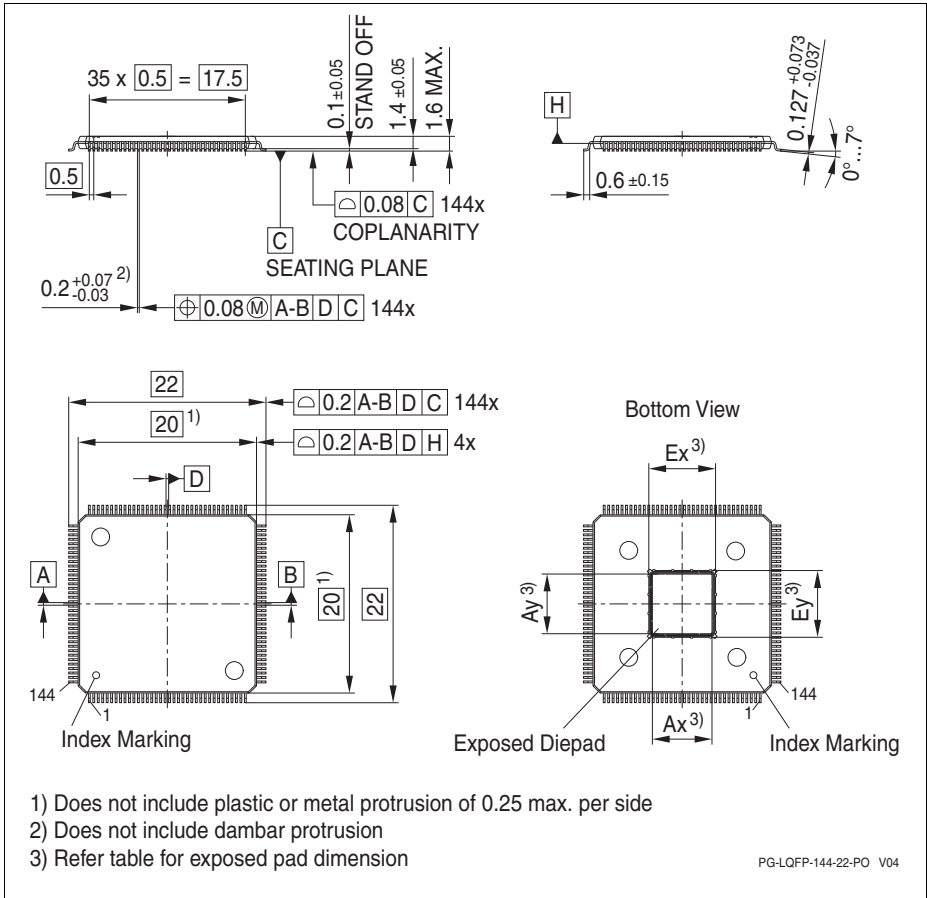

Figure 60 PG-LQFP-144-24 (Plastic Green Low Profile Quad Flat Package)

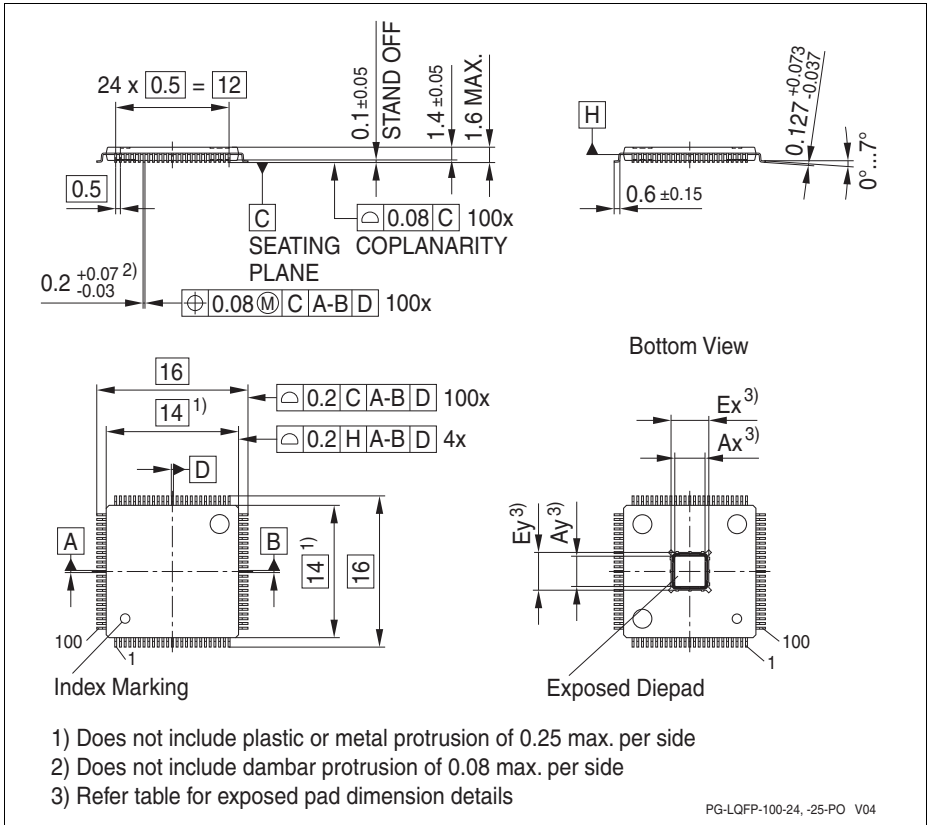

Figure 61 PG-LQFP-100-25 (Plastic Green Low Profile Quad Flat Package)

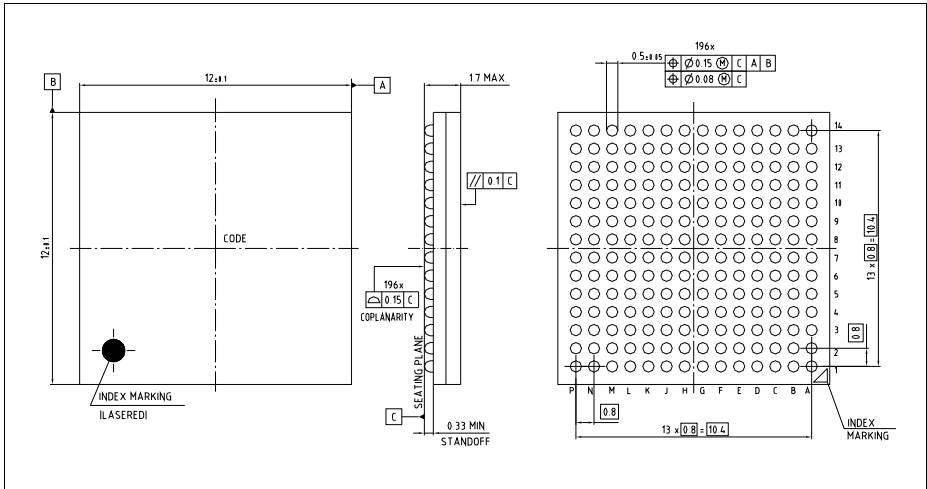

Figure 62 PG-LFBGA-196-2 (Plastic Green Low Profile Fine Pitch Ball Grid Array)

All dimensions in mm.

You can find complete information about Infineon packages, packing and marking in our Infineon Internet Page “Packages”: <http://www.infineon.com/packages>

5 Quality Declarations

The qualification of the XMC4[78]00 is executed according to the JEDEC standard JESD471.

Note: For automotive applications refer to the Infineon automotive microcontrollers.

Table 72 Quality Parameters

Parameter	Symbol	Values			Unit	Note / Test Condition
		Min.	Typ.	Max.		
Operation lifetime	t_{OP} CC	20	–	–	a	$T_J \leq 109^\circ\text{C}$, device permanent on
ESD susceptibility according to Human Body Model (HBM)	V_{HBM} SR	–	–	3 000	V	EIA/JESD22-A114-B
ESD susceptibility according to Charged Device Model (CDM)	V_{CDM} SR	–	–	1 000	V	Conforming to JESD22-C101-C
Moisture sensitivity level	MSL CC	–	–	3	–	JEDEC J-STD-020D
Soldering temperature	T_{SDR} SR	–	–	260	$^\circ\text{C}$	Profile according to JEDEC J-STD-020D

www.infineon.com

Published by Infineon Technologies AG

Mouser Electronics

Authorized Distributor

Click to View Pricing, Inventory, Delivery & Lifecycle Information:

Infineon:

[XMC4700F144F2048AAXQMA1](#) [XMC4700F144K2048AAXQMA1](#) [XMC4800F100K2048AAXQMA1](#)
[XMC4800F100F2048AAXQMA1](#) [XMC4800F144F2048AAXQMA1](#) [XMC4700F100K2048AAXQMA1](#)
[XMC4700F100F2048AAXQMA1](#) [XMC4800F144K2048AAXQMA1](#) [XMC4800E196F1024AAXQMA1](#)
[XMC4800E196K1024AAXQMA1](#) [XMC4700E196K2048AAXQMA1](#) [XMC4700E196F2048AAXQMA1](#)
[XMC4800F100F1536AAXQMA1](#) [XMC4800F144F1024AAXQMA1](#) [XMC4800F144K1024AAXQMA1](#)
[XMC4800F100K1536AAXQMA1](#) [XMC4700F144F1536AAXQMA1](#) [XMC4800E196F1536AAXQMA1](#)
[XMC4700F144K1536AAXQMA1](#) [XMC4800E196K2048AAXQMA1](#) [XMC4800E196F2048AAXQMA1](#)
[XMC4800F100K1024AAXQMA1](#) [XMC4700E196K1536AAXQMA1](#) [XMC4700E196F1536AAXQMA1](#)
[XMC4800F100F1024AAXQMA1](#) [XMC4700F100K1536AAXQMA1](#) [XMC4800F144F1536AAXQMA1](#)
[XMC4800F144K1536AAXQMA1](#) [XMC4700F100F1536AAXQMA1](#)