



Specific Lighting Product Data Sheet LTSA-3528ZEKT

Spec No. :

Created Date: 2017/03/23

Revision: 1.0

BNS-OD-FC001/A

**Specific Lighting
LTSA-3528ZEKT**

Specific Lighting

LTSA-3528ZEKT

<u>Rev</u>	<u>Description</u>	<u>By</u>	<u>Date</u>
1.0	New data sheet	Harvey Lee	03/23/2017
Above data for PD and Customer tracking only			

Customer Name:

Customer Signature:

Print Name:

LiteON Sales Signature:

Print Name:

Specific Lighting LTSA-3528ZEKT

1. Description

SMD LEDs from Lite-On are available in miniature sizes and special configurations for automated PC board assembly and space-sensitive applications. These SMD LEDs are suitable for use in a wide variety of electronic equipment, including cordless and cellular phones, notebook computers, network systems etc.

1.1 Features

- Package in 8mm tape on 7" diameter reels
- EIA STD package
- I.C. compatible
- Compatible with automatic placement equipment
- Compatible with infrared reflow solder process
- Preconditioning: accelerate to JEDEC level 3

1.2 Applications

- Aftermarket: accessory applications,

2. Package Dimensions

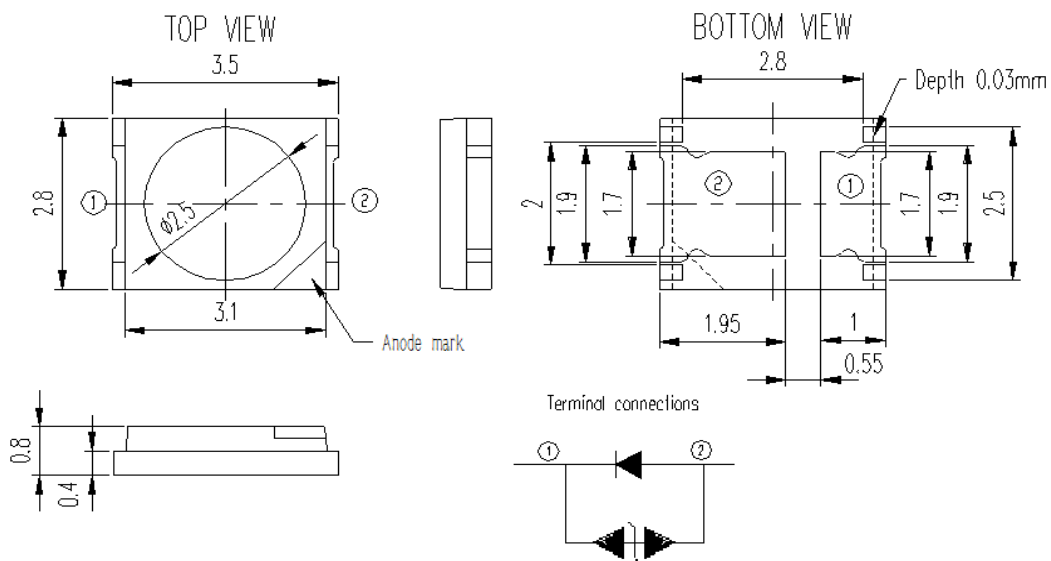

Part No.	Lens Color	Source Color
LTSA-3528ZEKT	Water Clear	AllnGaP Red

Notes:

1. All dimensions are in millimeters.
2. Tolerance is ± 0.2 mm (.008") unless otherwise noted.

Specific Lighting LTSA-3528ZEKT

3. Rating and Characteristics

3.1 Absolute Maximum Ratings at Ta=25°C

Parameter	LTSA-3528ZEKT	Unit
Power Dissipation	520	mW
Peak Forward Current (1/10 Duty Cycle, 0.1ms Pulse Width)	270	mA
DC Forward Current	200	mA
Operating Temperature Range	-40°C to + 100°C	
Storage Temperature Range	-40°C to + 100°C	

3.2 Suggest IR Reflow Condition for Pb Free Process:

IR-Reflow Soldering Profile for lead free soldering (Acc. to J-STD-020)

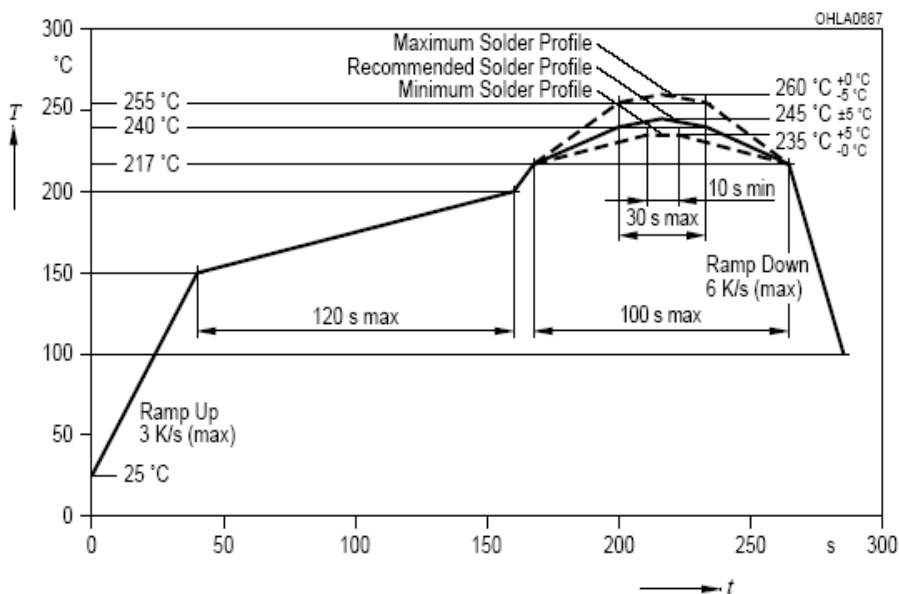

Specific Lighting LTSA-3528ZEKT

3.3 Electrical / Optical Characteristics at Ta=25°C

Parameter	Symbol	Part No. LTSA-	Min.	Typ.	Max.	Unit.	Test Condition
Luminous Flux	Φ_V	3528ZEKT	14	-	24	lm	IF = 150mA Note 1
Luminous Intensity	Φ_V	3528ZEKT	4200		7200	mcd	IF = 150mA Note 1
Viewing Angle	$2\theta_{1/2}$	3528ZEKT		120		deg	Note 2 (Fig.2)
Peak Emission Wavelength	λ_P	3528ZEKT	-	621	-	nm	Measurement @Peak (Fig.1)
Dominant Wavelength	λ_d	3528ZEKT	620	-	630	nm	IF = 150mA Note 3
Spectral Line Half-Width	$\Delta\lambda$	3528ZEKT		20		nm	
Forward Voltage	VF	3528ZEKT	1.8	-	2.6	V	IF = 150mA Note 4
Forward Voltage	VF	3528ZEKT	-	-	2.4	V	IF = 90mA Note 4
Reverse Current	IR	3528ZEKT	-	-	10	μ A	VR = 10V Note 5
ESD-Withstand Voltage	ESD	3528ZEKT	2K	-	-	V	HBM

Notes:

1. Luminous intensity is measured with a light sensor and filter combination that approximates the CIE eye-response curve
2. $\theta_{1/2}$ is the off-axis angle at which the luminous intensity is half the axial luminous intensity.
3. The dominant wavelength, λ_d is derived from the CIE chromaticity diagram and represents the single wavelength which defines the color of the device. Dominant Wavelength Tolerance is +/- 1nm.
4. Forward Voltage Tolerance is +/- 0.1 volt.
5. Reverse voltage (VR) condition is applied to IR test only. The device is not designed for reverse operation.

**Specific Lighting
LTSA-3528ZEKT**

4. Bin Rank

■ Vf Rank

Forward Voltage		Unit : V @150mA	
Bin Code	Min.	Max.	
D2	1.8	2.0	
D3	2.0	2.2	
D4	2.2	2.4	
D5	2.4	2.6	

Tolerance for each forward voltage bin is +/- 0.1 volt

**Specific Lighting
LTSA-3528ZEKT**

■ IV Rank

Luminous Flux		Unit : lm @150mA	
Bin Code	Min.	Max.	mcd typ.
S5	14.0	16.0	4500
S6	16.0	18.0	5100
S7	18.0	20.0	5700
S8	20.0	22.0	6300
S9	22.0	24.0	6900

Tolerance for each Intensity bin is +/-11%

■ Wd Rank

Dominant wavelength (Wd)		Unit : nm @150mA	
Bin Code	Min.	Max.	
6	620	625	
7	625	630	

Tolerance for each Dominant wavelength bin is +/-11%

**Specific Lighting
LTSA-3528ZEKT**

5. Typical Electrical / Optical Characteristics Curves.

(25°C Ambient Temperature Unless Otherwise Noted)

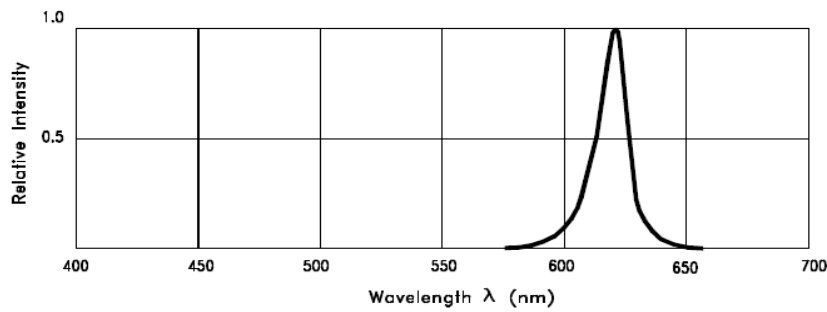

Fig.1 RELATIVE INTENSITY VS. WAVELENGTH

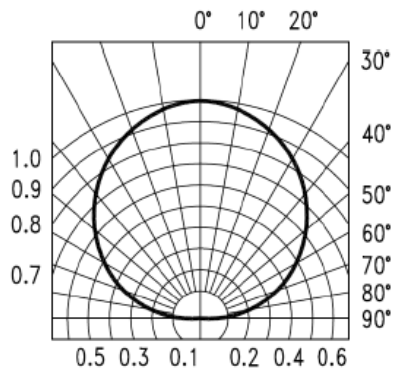

Fig. 2 SPATIAL DISTRIBUTION

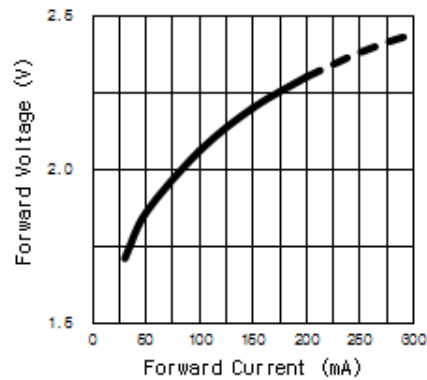

Fig. 3 FORWARD VOLTAGE V.S. FORWARD CURRENT

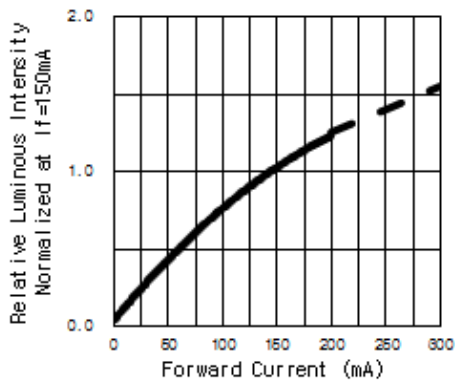

Fig. 4 RELATIVE LUMINOUS INTENSITY V.S. FORWARD CURRENT

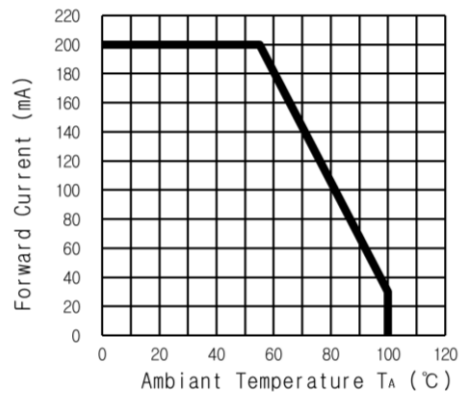

Fig.5 FORWARD CURRENT DERATING CURVE

Specific Lighting LTSA-3528ZEKT

6. User Guide

6.1 Cleaning

Do not use unspecified chemical liquid to clean LED they could harm the package.

If clean is necessary, immerse the LED in ethyl alcohol or in isopropyl alcohol at normal temperature for less one minute.

6.2 Recommend Printed Circuit Board Attachment Pad

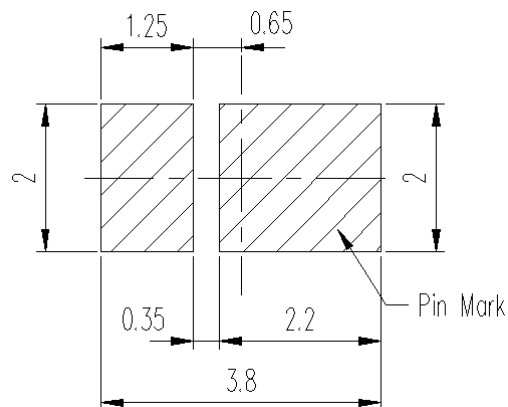

Note:

1. Suggest stencil thickness is maximum 0.10mm.

6.3 Package Dimensions Of Tape And Reel

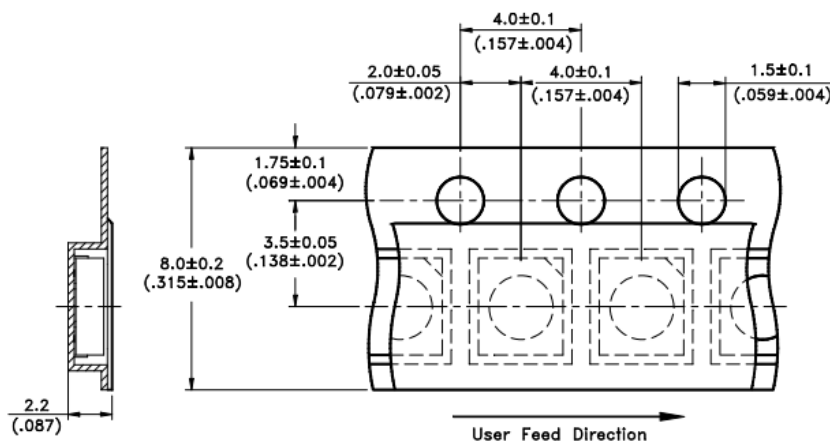

Note:

1. All dimensions are in millimeters (inches).

Specific Lighting
LTSA-3528ZEKT

6.4 Package Dimensions of Reel

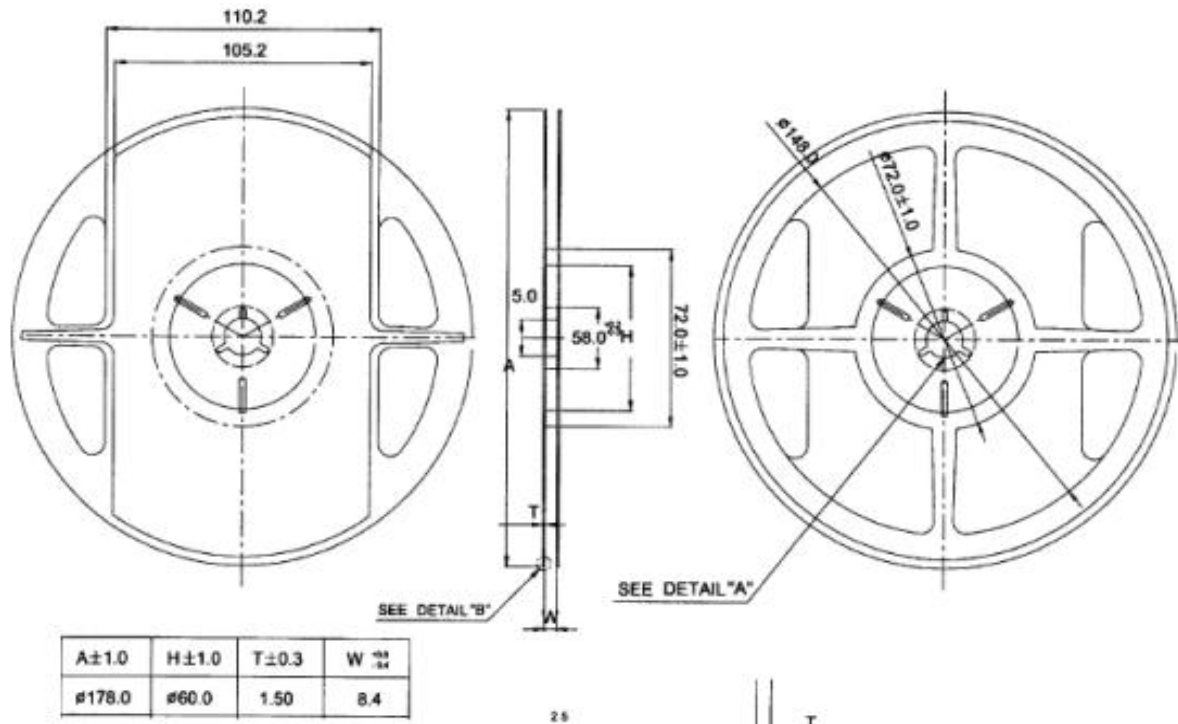

Notes:

1. Empty component pockets sealed with top cover tape.
2. 7 inch reel-2000 pieces per reel.
3. Minimum packing quantity is 500 pieces for remainders.
4. The maximum number of consecutive missing lamps is two.
5. In accordance with EIA-481 specifications.

Specific Lighting LTSA-3528ZEKT

7. Cautions

7.1 Application

The LEDs described here are intended to be used for ordinary electronic equipment (such as office equipment, communication equipment and household applications). Consult Liteon's Sales in advance for information on applications in which exceptional reliability is required, particularly when the failure or malfunction of the LEDs may directly jeopardize life or health (such as in aviation, transportation, traffic control equipment, medical and life support systems and safety devices).

7.2 Storage

The package is sealed:

The LEDs should be stored at 30°C or less and 70%RH or less. And the LEDs are limited to use within one year, while the LEDs is packed in moisture-proof package with the desiccants inside.

The package is opened:

The storage ambient for the LEDs should not exceed 30°C temperature and 60% relative humidity.

It is recommended that LEDs out of their original packaging are IR-reflowed within 168 hours.

For extended storage out of their original packaging, it is recommended that the LEDs be stored in a sealed container with appropriate desiccant, or in a desiccators with nitrogen ambient.

LEDs stored out of their original packaging for more than 168hrs should be baked at about 60 °C for at least 48 hours before solder assembly.

7.3 Cleaning

Use alcohol-based cleaning solvents such as isopropyl alcohol to clean the LED if necessary.

7.4 Soldering

Recommended soldering conditions:

Reflow soldering		Soldering iron	
Pre-heat	150~200°C	Temperature	300°C Max.
Pre-heat time	120 sec. Max.	Soldering time	3 sec. Max.
Peak temperature	260°C Max.		(one time only)
Soldering time	10 sec. Max.(Max. two times)		

Notes:

Because different board designs use different number and types of devices, solder pastes, reflow ovens, and circuit boards, no single temperature profile works for all possible combinations.

However, you can successfully mount your packages to the PCB by following the proper guidelines and PCB-specific characterization.

LITE-ON Runs both component-level verification using in-house **KYRAMX98** reflow chambers and board-level assembly. The results of this testing are verified through post-reflow reliability testing .Profiles used at LITE-ON are based on JEDEC standards to ensure that all packages can be successfully and reliably surface mounted.

Figure on page3 shows a sample temperature profile compliant to JEDEC standards. You can use this example as a generic target to set up your reflow process. You should adhere to the JEDEC profile limits as well as specifications and recommendations from the solder paste manufacturer to avoid damaging the device and create a reliable solder joint.

Specific Lighting LTSA-3528ZEKT

7.5 Drive Method

A LED is a current-operated device. In order to ensure intensity uniformity on multiple LEDs connected in parallel in an application, it is recommended that a current limiting resistor be incorporated in the drive circuit, in series with each LED as shown in Circuit A below.

Circuit model A

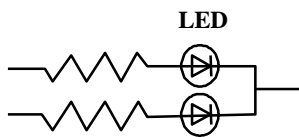

Circuit model B

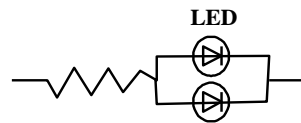

(A) Recommended circuit.

(B) The brightness of each LED might appear different due to the differences in the I-V characteristics of those LEDs.

7.6 ESD (Electrostatic Discharge)

Static Electricity or power surge will damage the LED.

Suggestions to prevent ESD damage:

- Use of a conductive wrist band or anti-electrostatic glove when handling these LEDs.
- All devices, equipment, and machinery must be properly grounded.
- Work tables, storage racks, etc. should be properly grounded.
- Use ion blower to neutralize the static charge which might have built up on surface of the LED's plastic lens as a result of friction between LEDs during storage and handling.

ESD-damaged LEDs will exhibit abnormal characteristics such as high reverse leakage current, low forward voltage, or "no lightup" at low currents.

To verify for ESD damage, check for "lightup" and V_f of the suspect LEDs at low currents.

The V_f of "good" LEDs should be $>2.0V@0.1mA$ for InGaN product and $>1.4V@0.1mA$ for AlInGaP product.

Specific Lighting LTSA-3528ZEKT

8. Reliability Test

8.1 Test Item:

No.	Test item	Test condition	Sample size	Reference standard
1	Pre-conditioning	MSL 3 125°C, 24 hrs baking Moisture Soak 60°C/60% 52 hrs Interval: 15mins ~ 4 hours to do IR-Reflow	180	JESD22 A-113
2	Resistance to soldering heat	Tsld = 260°C, 10sec. 3 times	30	JESD22 A-113
3	Solderability	Tsld=245± 5°C (Lead Free Solder, Coverage ≥ 95% of the ipped surface)	30	JEITA ED-4701 300 303
4	High Temperature Operating Life I	IF=200mA, Ta=55°C, 1000 hrs	30	EIAJ ED-4701/100 (101)
5	High Temperature Operating Life II	Ta=100°C., IF=30mA, 1000 hrs	30	EIAJ ED-4701/100 (101)
6	Low Temperature Operating Life	Ta=-40°C., IF=200mA, 1000 hrs	30	EIAJ ED-4701/100 (101)
7	High Temperature Storage	Ta=100°C., 1000 hrs	30	EIAJ ED-4701/200 (201)
8	Low Temperature Storage	Ta=-40°C, 1000 hrs	30	EIAJ ED-4701/200 (202)
9	High Temperature High Humidity Bias (HTHHB)	Ta=60°C, Rh=90%, IF=180mA, 1000 hrs	30	EIAJ ED-4701/100 (102)
10	Thermal Shock (air to air)	-40°C ± 5°C ~ 100 ± 5°C 30min 30min 300cycles	30	EIAJ ED-4701/300 (307)
11	Temperature Cycle	-40°C ~ 25°C ~ 100°C ~ 25°C 30min 5min 30min 5min 300cycles	30	EIAJ ED-4701/100 (105)

Specific Lighting LTSA-3528ZEKT

9. Others

The appearance and specifications of the product may be modified for improvement without prior notice.

10. Suggested Checking List

Training and Certification

1. Everyone working in a static-safe area is ESD-certified?
2. Training records kept and re-certification dates monitored?

Static-Safe Workstation & Work Areas

1. Static-safe workstation or work-areas have ESD signs?
2. All surfaces and objects at all static-safe workstation and within 1 ft measure less than 100V?
3. All ionizer activated, positioned towards the units?
4. Each work surface mats grounding is good?

Personnel Grounding

1. Every person (including visitors) handling ESD sensitive (ESDS) items wears wrist strap, heel strap or conductive shoes with conductive flooring?
2. If conductive footwear used, conductive flooring also present where operator stand or walk?
3. Garments, hairs or anything closer than 1 ft to ESD items measure less than 100V*?
4. Every wrist strap or heel strap/conductive shoes checked daily and result recorded for all DLs?
5. All wrist strap or heel strap checkers calibration up to date?

Note: *50V for InGaN LED.

Device Handling

1. Every ESDS items identified by EIA-471 labels on item or packaging?
2. All ESDS items completely inside properly closed static-shielding containers when not at static-safe workstation?
3. No static charge generators (e.g. plastics) inside shielding containers with ESDS items?
4. All flexible conductive and dissipative package materials inspected before reuse or recycles?

Others

1. Audit result reported to entity ESD control coordinator?
2. Corrective action from previous audits completed?
3. Are audit records complete and on file?