

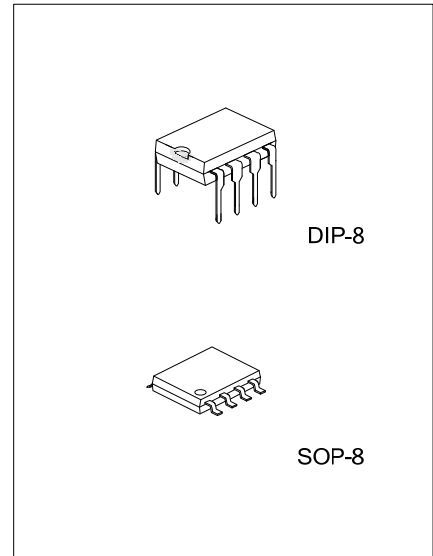

MC33178

LINEAR INTEGRATED CIRCUIT

HIGH OUTPUT CURRENT LOW NOISE, LOW POWER OPERATIONAL AMPLIFIERS



DESCRIPTION

The UTC **MC33178** is a Bipolar dual operational amplifier with high performance concepts. Its all NPN output stage exhibits no deadband crossover distortion, large output voltage swing, and an excellent phase and gain margin. It also provides a low open loop high frequency output impedance with symmetrical source and sink AC frequency performance. This device use of high frequency PNP input transistors to produce amplifiers exhibiting low input offset voltage, noise and distortion.

FEATURES

- * Dual supply operation from $\pm 2V$ to $\pm 18V$
- * High slew rate: $2.0V/\mu s$
- * Large output voltage swing
- * 600Ω output drive capability
- * Low offset voltage: $0.15mV$ (Mean)
- * Low total harmonic distortion: 0.0024% (@ 1.0 kHz w/ 600Ω load)
- * High gain bandwidth: $5.0MHz$

ORDERING INFORMATION

Ordering Number		Package	Packing
Lead Free	Halogen Free		
MC33178L-D08-T	MC33178G-D08-T	DIP-8	Tube
MC33178L-S08-R	MC33178G-S08-R	SOP-8	Tape Reel

<p>MC33178G-D08-T</p> <p>(1)Packing Type (2)Package Type (3)Green Package</p>	<p>(1) T: Tube, R: Tape Reel (2) D08: DIP-8, S08: SOP-8 (3) G: Halogen Free and Lead Free, L: Lead Free</p>
---	---

MARKING

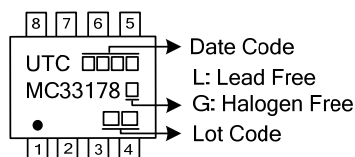

■ PIN CONFIGURATION

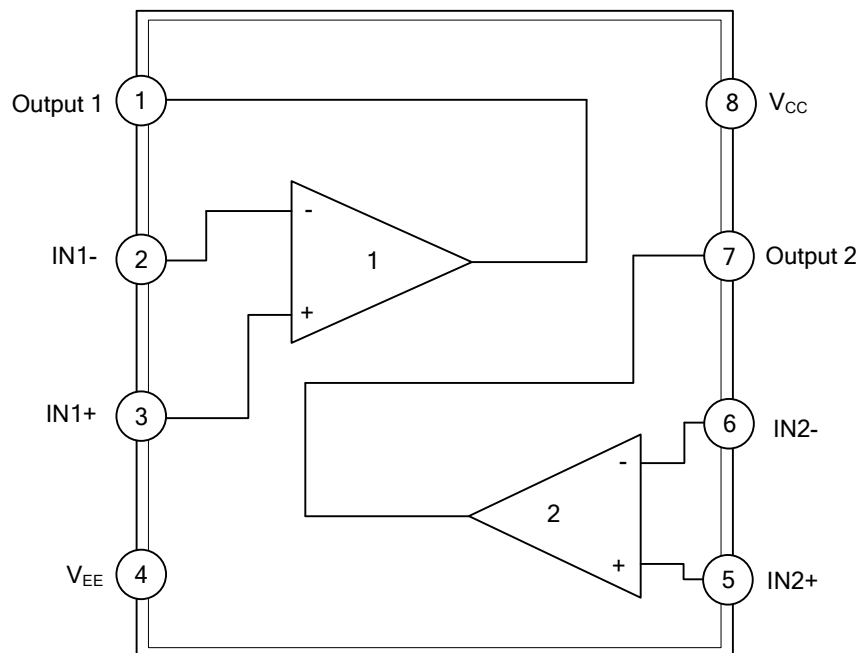

■ PIN DESCRIPTION

PIN NO.	PIN NAME	DESCRIPTION
1	Output 1	The output of channel 1
2, 3	IN1-, IN1+	The input of channel 1
4	V_{EE}	Power supply
5, 6	IN2+, IN2-	The input of channel 2
7	Output 2	The output of channel 2
8	V_{CC}	Power supply

■ BLOCK DIAGRAM

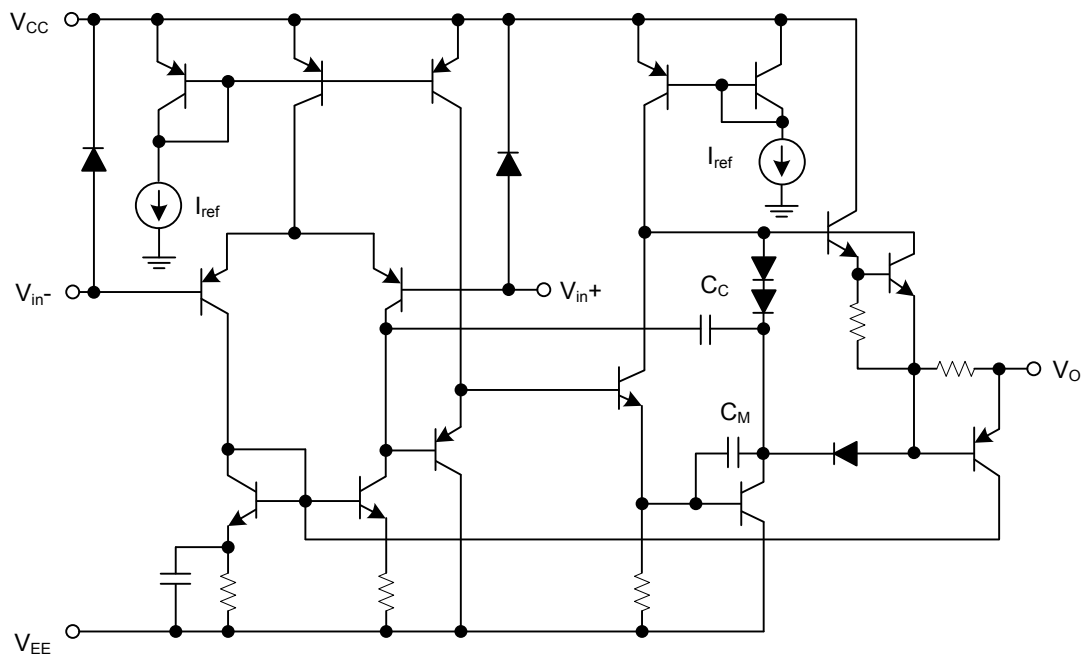

■ ABSOLUTE MAXIMUM RATING

PARAMETER	SYMBOL	RATINGS	UNIT
Supply Voltage (V_{CC} to V_{EE})	V_S	+36	V
Input Differential Voltage Range	V_{IDR}	(Note 2)	V
Input Voltage Range	V_{IR}	(Note 2)	V
Output Short Circuit Duration (Note 3)	t_{SC}	Indefinite	sec
Maximum Power Dissipation	P_D	(Note 3)	mW
Maximum Junction Temperature	T_J	+150	°C
Operating Temperature Range	T_{OPR}	-40 ~ +85	°C
Storage Temperature	T_{STG}	-60~+150	°C

Notes: 1. Absolute maximum ratings are those values beyond which the device could be permanently damaged.

Absolute maximum ratings are stress ratings only and functional device operation is not implied.

2. Either or both input voltages must not exceed the magnitude of V_{CC} or V_{EE} .

3. Power dissipation must be considered to ensure maximum junction temperature (T_J) is not exceeded.

■ DC ELECTRICAL CHARACTERISTICS

($V_{CC}=+15$ V, $V_{EE}=-15$ V, $T_A=25^\circ\text{C}$, unless otherwise specified)

PARAMETER	SYMBOL	TEST CONDITIONS	MIN	TYP	MAX	UNIT			
Input Offset Voltage	$ V_{IO} $	$R_S=50\Omega$, $V_{CM}=0V$, $V_O=0V$ $V_{CC}=+2.5V$, $V_{EE}=-2.5V \sim V_{CC}=+15V$, $V_{EE}=-15V$		0.15	3.0	mV			
Average Temperature Coefficient of Input Offset Voltage	$\Delta V_{IO}/\Delta T$	$R_S=50\Omega$, $V_{CM}=0V$, $V_O=0V$, $T_A=-40^\circ\text{C} \sim +85^\circ\text{C}$		2.0		$\mu\text{V}/^\circ\text{C}$			
Input Bias Current	I_{IB}	$V_{CM}=0V$, $V_O=0V$		100	500	nA			
Input Offset Current	$ I_{IO} $	$V_{CM}=0V$, $V_O=0V$		5.0	50	nA			
Common Mode Input Voltage Range	V_{ICR}	$\Delta V_{IO}=5.0\text{mV}$, $V_O=0V$	+13	+14 -14	-13	V			
Large Signal Voltage Gain	A_{VOL}	$V_O=-10V \sim +10V$, $R_L=600\Omega$	50k	200k		V/V			
Output Voltage Swing	V_{O+}	$V_{ID}=\pm 1.0V$	$V_{CC}=+15V$, $V_{EE}=-15V$	$R_L=300\Omega$		+12	V		
	V_{O-}			$R_L=300\Omega$		-12	V		
	V_{O+}			$R_L=600\Omega$	+12	+13.6		V	
	V_{O-}			$R_L=600\Omega$		-13	-12	V	
	V_{O+}			$R_L=2.0k\Omega$	+13	+14		V	
	V_{O-}			$R_L=2.0k\Omega$		-13.8	-13	V	
	V_{OL}			$V_{CC}=+2.5V$, $V_{EE}=-2.5V$	$R_L=600\Omega$	1.1	1.6		V
	V_{OH}			$R_L=600\Omega$		-1.6	-1.1	V	
Common Mode Rejection	CMR	$V_{in}=\pm 13V$	80	110		dB			
Power Supply Rejection	PSR	$V_{CC}/V_{EE}=+15V/-15V$, $+5.0V/-15V$, $+15V/-5.0V$	80	110		dB			
Output Short Circuit Current	I_{SC}	$V_{ID}=1.0V$, Output to Ground	Source ($V_{CC}=2.5V \sim 15V$)	+50	+80		mA		
			Sink ($V_{EE}=-2.5V \sim -15V$)		-100	-50	mA		
Power Supply Current (Dual)	I_D	$V_O=0V$			1.4	mA			
		$V_{CC}=2.5V$, $V_{EE}=-2.5V \sim$ $V_{CC}=+15V$, $V_{EE}=-15V$							

■ AC ELECTRICAL CHARACTERISTICS ($V_{CC}=+15\text{ V}$, $V_{EE}=-15\text{ V}$, $T_A=25^\circ\text{C}$, unless otherwise noted.)

PARAMETER	SYMBOL	TEST CONDITIONS	MIN	TYP	MAX	UNIT
Slew Rate	SR	$V_{in}=-10\text{V}\sim+10\text{ V}$, $R_L=2.0\text{k}\Omega$, $C_L=100\text{Pf}$ $A_V=+1.0\text{V}$	1.2	2		V/ μs
Gain Bandwidth Product	GBW	$f=100\text{kHz}$	2.5	5		MHz
AC Voltage Gain	A_{VO}	$R_L=600\Omega$, $V_O=0\text{V}$, $f=20\text{kHz}$		50		dB
Unity Gain Frequency	f_U	Open-Loop, $R_L=600\Omega$, $C_L=0\text{pF}$		3		MHz
Gain Margin	A_m	$R_L=600\Omega$, $C_L=0\text{pF}$		15		dB
Phase Margin	ϕ_m	$R_L=600\Omega$, $C_L=0\text{pF}$		60		Degrees
Channel Separation	CS	$f=100\text{Hz}\sim 20\text{kHz}$		-120		dB
Power Bandwidth	BW_p	$V_O=20\text{Vpp}$, $R_L=600\Omega$, $\text{THD}\leq 1.0\%$		32		kHz
Total Harmonic Distortion	THD	$R_L=600\Omega$, $V_O=2.0\text{Vpp}$, $A_V=+1.0\text{V}$	$f=1.0\text{kHz}$	0.0024		%
			$f=10\text{kHz}$	0.014		%
			$f=20\text{kHz}$	0.024		%
Open Loop Output Impedance	$ Z_O $	$V_O=0\text{V}$, $f=3.0\text{MHz}$, $A_V=10\text{V}$		150		Ω
Differential Input Resistance	R_{IN}	$V_{CM}=0\text{V}$		200		$\text{k}\Omega$
Differential Input Capacitance	C_{IN}	$V_{CM}=0\text{V}$		10		pF
Equivalent Input Noise Voltage	e_n	$R_S=100\Omega$	$f=10\text{Hz}$	8		$\text{nV}/\sqrt{\text{Hz}}$
			$f=1.0\text{kHz}$	7.5		$\text{nV}/\sqrt{\text{Hz}}$
Equivalent Input Noise Current	i_n	$f=10\text{Hz}$	0.33			$\text{pA}/\sqrt{\text{Hz}}$
		$f=1.0\text{kHz}$	0.15			$\text{pA}/\sqrt{\text{Hz}}$

UTC assumes no responsibility for equipment failures that result from using products at values that exceed, even momentarily, rated values (such as maximum ratings, operating condition ranges, or other parameters) listed in products specifications of any and all UTC products described or contained herein. UTC products are not designed for use in life support appliances, devices or systems where malfunction of these products can be reasonably expected to result in personal injury. Reproduction in whole or in part is prohibited without the prior written consent of the copyright owner. The information presented in this document does not form part of any quotation or contract, is believed to be accurate and reliable and may be changed without notice.