



AiP74AVC4T245

4-bit Dual Supply Translating Transceiver; 3-state

Product Specification

Specification Revision History:

Version	Date	Description
2019-10-A1	2019-10	New
2022-08-A2	2022-08	Add VQFN16 package form



Contents

1、 General Description.....	3
2、 Block Diagram And Pin Description	5
2.1、 Block Diagram	5
2.2、 Pin Configurations.....	6
2.3、 Pin Description	6
3、 Electrical Parameter	7
3.1、 Absolute Maximum Ratings.....	7
3.2、 Recommended Operating Conditions	8
3.3、 Electrical Characteristics	8
3.3.1、 DC Characteristics 1	8
3.3.2、 DC Characteristics 2	9
3.3.3、 DC Characteristics 3	11
3.3.4、 AC Characteristics 1	13
3.3.5、 AC Characteristics 2	14
3.3.6、 AC Characteristics 3	14
3.3.7、 AC Characteristics 4	15
3.3.8、 AC Characteristics 5	16
4、 Testing Circuit	17
4.1、 AC Testing Circuit	17
4.2、 AC Testing Waveforms.....	18
4.3、 Measurement Points	18
4.4、 Test Data	19
5、 Characteristic Curve.....	19
6、 Package Information	23
6.1、 SOP16	23
6.2、 TSSOP16.....	24
6.3、 DHVQFN16	25
6.4、 VQFN16.....	26
7、 Statements And Notes	27
7.1、 The name and content of Hazardous substances or Elements in the product	27
7.2、 Notes	27



1、 General Description

The AiP74AVC4T245 is an 4-bit, dual supply transceiver that enables bidirectional level translation. The device can be used as two 2-bit transceivers or as a 4-bit transceiver. It features four 2-bit input-output ports (nAn and nBn), a direction control input (nDIR), a output enable input ($\overline{\text{nOE}}$) and dual supply pins ($V_{CC(A)}$ and $V_{CC(B)}$). Both $V_{CC(A)}$ and $V_{CC(B)}$ can be supplied at any voltage between 0.8V and 3.6V making the device suitable for translating between any of the low voltage nodes (0.8V, 1.2V, 1.5V, 1.8V, 2.5V and 3.3V). Pins nAn, $\overline{\text{nOE}}$ and nDIR are referenced to $V_{CC(A)}$ and pins nBn are referenced to $V_{CC(B)}$. A HIGH on nDIR allows transmission from nAn to nBn and a LOW on nDIR allows transmission from nBn to nAn.

The output enable input ($\overline{\text{nOE}}$) can be used to disable the outputs so the buses are effectively isolated.

The device is fully specified for partial power-down applications using I_{OFF} . The I_{OFF} circuitry disables the output, preventing any damaging backflow current through the device when it is powered down. In suspend mode when either $V_{CC(A)}$ or $V_{CC(B)}$ are at GND level, both nAn and nBn are in the high-impedance OFF-state.

Features:

- Wide supply voltage range:
 $V_{CC(A)}$: 0.8V to 3.6V
 $V_{CC(B)}$: 0.8V to 3.6V
- Suspend mode
- Inputs accept voltages up to 3.6V
- I_{OFF} circuitry provides partial Power-down mode operation
- Specified from -40°C to +125°C
- Packaging information: SOP16/TSSOP16/DHVQFN16/VQFN16

**Ordering Information:****Tube packing specifications:**

Type number	Packaging form	Marking code	Tube quantity	Boxed tube quantity	Boxed quantity	Notes
AiP74AVC4T245SA16.TB	SOP16	74AVC4T245	50 PCS/tube	200 tube/box	10000 PCS/box	Dimensions of plastic enclosure: 10.0mm×3.9mm Pin spacing: 1.27mm
AiP74AVC4T245TA16.TB	TSSOP16	74AVC4T245	96 PCS/tube	200 tube/box	19200 PCS/box	Dimensions of plastic enclosure: 5.0mm×4.4mm Pin spacing: 0.65mm

Reel packing specifications:

Type number	Packaging form	Marking code	Reel quantity	Boxed reel quantity	Notes
AiP74AVC4T245SA16.TR	SOP16	74AVC4T245	4000 PCS/reel	8000 PCS/box	Dimensions of plastic enclosure: 10.0mm×3.9mm Pin spacing: 1.27mm
AiP74AVC4T245TA16.TR	TSSOP16	74AVC4T245	5000 PCS/reel	10000 PCS/box	Dimensions of plastic enclosure: 5.0mm×4.4mm Pin spacing: 0.65mm
AiP74AVC4T245QE16.TR	DHVQFN16	74AVC4T245	3000 PCS/reel	3000 PCS/box	Dimensions of plastic enclosure: 2.5mm×3.5mm Pin spacing:0.5mm

Note: If the physical information is inconsistent with the ordering information, please refer to the actual product.



2、Block Diagram And Pin Description

2.1、Block Diagram

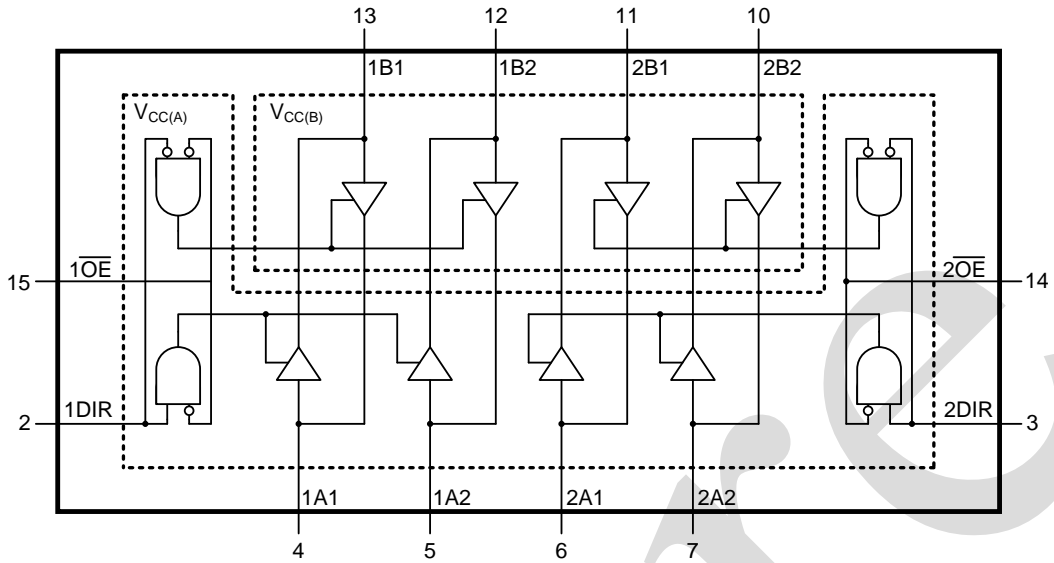

Figure 1. Logic symbol

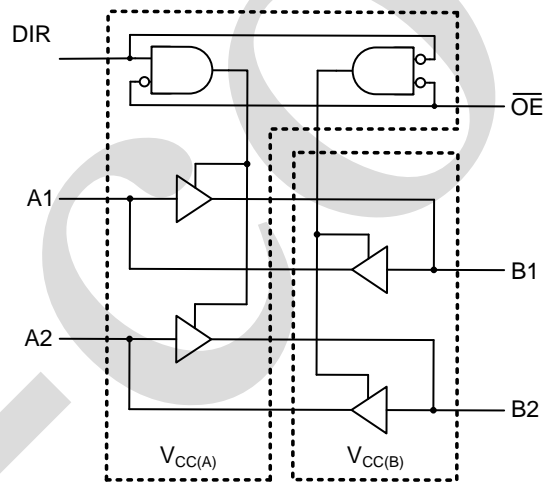
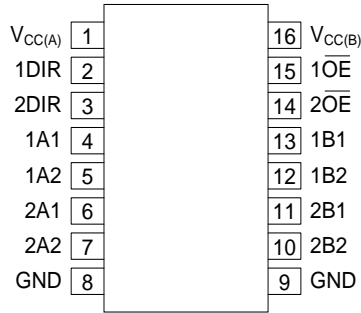
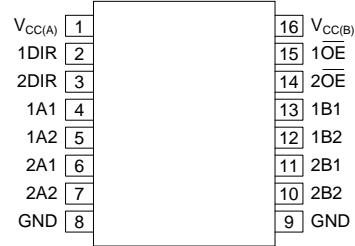
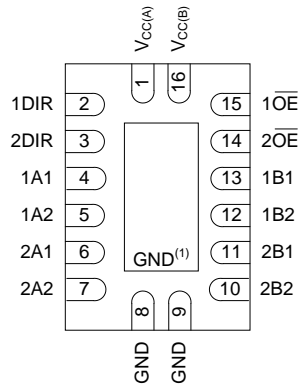
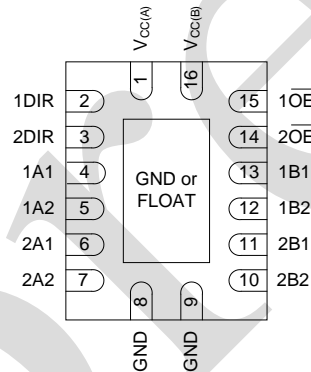

Figure 2. Logic diagram (one 2-bit transceiver)



2.2、Pin Configurations

**SOP16****TSSOP16****DHVQFN16****VQFN16**

Note: (1) This is not a supply pin, the substrate is attached to this pad using conductive die attach material. There is no electrical or mechanical requirement to solder this pad. However if it is soldered the solder land should remain floating or be connected to GND.

2.3、Pin Description

Pin No.	Pin Name	Description
1	$V_{CC(A)}$	supply voltage A (nAn, nOE and nDIR inputs are referenced to $V_{CC(A)}$)
2	1DIR	direction control
3	2DIR	direction control
4	1A1	data input or output
5	1A2	data input or output
6	2A1	data input or output
7	2A2	data input or output
8	GND	ground (0V)
9	GND	ground (0V)
10	2B2	data input or output
11	2B1	data input or output
12	1B2	data input or output
13	1B1	data input or output
14	$2\overline{OE}$	output enable input (active LOW)
15	$1\overline{OE}$	output enable input (active LOW)
16	$V_{CC(B)}$	supply voltage B (nBn inputs are referenced to $V_{CC(B)}$)



2.4、Function Table

H=HIGH voltage level; L=LOW voltage level; X=don't care; Z=high-impedance OFF-state.

Supply voltage	Input		Input/Output ^[1]	
$V_{CC(A)}, V_{CC(B)}$	$\overline{nOE}^{[2]}$	nDIR ^[2]	nAn ^[2]	nBn ^[2]
0.8V to 3.6V	L	L	nAn=nBn	input
0.8V to 3.6V	L	H	input	nBn=nAn
0.8V to 3.6V	H	X	Z	Z
GND ^[1]	X	X	Z	Z

Note:

[1] If at least one of $V_{CC(A)}$ or $V_{CC(B)}$ is at GND level, the device goes into suspend mode.

[2] The nAn, nDIR and \overline{nOE} input circuit is referenced to $V_{CC(A)}$; The nBn input circuit is referenced to $V_{CC(B)}$.

3、Electrical Parameter

3.1、Absolute Maximum Ratings

($T_{amb}=25^{\circ}C$, All voltage referenced to GND, unless otherwise specified)

Characteristic	Symbol	Conditions	Min.	Max.	Unit
supply voltage A	$V_{CC(A)}$	-	-0.5	+4.6	V
supply voltage B	$V_{CC(B)}$	-	-0.5	+4.6	V
input clamping current	I_{IK}	$V_I < 0V$	-50	-	mA
input voltage	V_I	-	-0.5	+4.6	V
output clamping current	I_{OK}	$V_O < 0V$	-50	-	mA
output voltage	V_O	Active mode ^{[1][2][3]}	-0.5	$V_{CCO}+0.5$	V
		Suspend or 3-state mode ^[1]	-0.5	+4.6	V
output current	I_O	$V_O=0V$ to V_{CCO} ^[2]	-	± 50	mA
supply current	I_{CC}	per $V_{CC(A)}$ or $V_{CC(B)}$ pin	-	100	mA
ground current	I_{GND}	per GND pin	-100	-	mA
storage temperature	T_{stg}	-	-65	+150	$^{\circ}C$
total power dissipation	P_{tot}	-	-	500	mW
soldering temperature	T_L	10s	DIP	245	$^{\circ}C$
			SOP	250	$^{\circ}C$

Note:

[1] The minimum input voltage ratings and output voltage ratings may be exceeded if the input and output current ratings are observed.

[2] V_{CCO} is the supply voltage associated with the output port.

[3] $V_{CCO}+0.5V$ should not exceed 4.6V.



3.2、Recommended Operating Conditions

Parameter	Symbol	Conditions	Min.	Typ.	Max.	Unit
supply voltage A	$V_{CC(A)}$	-	0.8	-	3.6	V
supply voltage B	$V_{CC(B)}$	-	0.8	-	3.6	V
input voltage	V_I	-	0	-	3.6	V
output voltage	V_O	Active mode ^[1]	0	-	V_{CCO}	V
		Suspend or 3-state mode	0	-	3.6	V
ambient temperature	T_{amb}	-	-40	-	+125	°C
input transition rise and fall rate	$\Delta t/\Delta V$	$V_{CCI}=0.8V$ to $3.6V$ ^[2]	-	-	5	ns/V

Note:

[1] V_{CCO} is the supply voltage associated with the output port.

[2] V_{CCI} is the supply voltage associated with the input port.

3.3、Electrical Characteristics

3.3.1、DC Characteristics 1

($T_{amb}=25^\circ C$, voltages are referenced to GND (ground=0V), unless otherwise specified)^{[1][2]}

Parameter	Symbol	Conditions	Min.	Typ.	Max.	Unit
HIGH-level output voltage	V_{OH}	$V_I=V_{IH}$ or V_{IL} $I_O=-1.5mA$; $V_{CC(A)}=V_{CC(B)}=0.8V$	-	0.69	-	V
LOW-level output voltage	V_{OL}	$V_I=V_{IH}$ or V_{IL} $I_O=1.5mA$; $V_{CC(A)}=V_{CC(B)}=0.8V$	-	0.07	-	V
input leakage current	I_I	nDIR, nOE input; $V_I=0V$ or $3.6V$; $V_{CC(A)}=V_{CC(B)}=0.8V$ to $3.6V$	-	± 0.025	± 0.25	μA
OFF-state output current	I_{OZ}	A or B port; $V_O=0V$ or V_{CCO} ; $V_{CC(A)}=V_{CC(B)}=3.6V$ ^[3]	-	± 0.5	± 2.5	μA
		suspend mode A port; $V_O=0V$ or V_{CCO} ; $V_{CC(A)}=3.6V$; $V_{CC(B)}=0V$ ^[3]	-	± 0.5	± 2.5	μA
		suspend mode B port; $V_O=0V$ or V_{CCO} ; $V_{CC(A)}=0V$; $V_{CC(B)}=3.6V$ ^[3]	-	± 0.5	± 2.5	μA
power-off leakage current	I_{OFF}	A port; V_I or $V_O=0V$ to $3.6V$; $V_{CC(A)}=0V$; $V_{CC(B)}=0.8V$ to $3.6V$	-	± 0.1	± 1	μA
		B port; V_I or $V_O=0V$ to $3.6V$; $V_{CC(B)}=0V$; $V_{CC(A)}=0.8V$ to $3.6V$	-	± 0.1	± 1	μA
input capacitance	C_I	nDIR, nOE input; $V_I=0V$ or $3.3V$; $V_{CC(A)}=V_{CC(B)}=3.3V$	-	1.0	-	pF
input/output capacitance	$C_{I/O}$	A and B port; $V_O=3.3V$ or $0V$; $V_{CC(A)}=V_{CC(B)}=3.3V$	-	4.0	-	pF

Note:

[1] V_{CCO} is the supply voltage associated with the output port.

[2] V_{CCI} is the supply voltage associated with the data input port.

[3] For I/O ports, the parameter I_{OZ} includes the input leakage current.



3.3.2、DC Characteristics 2

($T_{amb}=-40^{\circ}\text{C}$ to $+85^{\circ}\text{C}$, voltages are referenced to GND (ground=0V), unless otherwise specified) ^{[1][2]}

Parameter	Symbol	Conditions	Min.	Typ.	Max.	Unit	
HIGH-level input voltage	V_{IH}	data input	$V_{CCI}=0.8\text{V}$	$0.70V_{CCI}$	-	-	V
			$V_{CCI}=1.1\text{V}$ to 1.95V	$0.65V_{CCI}$	-	-	V
			$V_{CCI}=2.3\text{V}$ to 2.7V	1.6	-	-	V
			$V_{CCI}=3.0\text{V}$ to 3.6V	2	-	-	V
		nDIR, nOE input	$V_{CC(A)}=0.8\text{V}$	$0.70V_{CC(A)}$	-	-	V
			$V_{CC(A)}=1.1\text{V}$ to 1.95V	$0.65V_{CC(A)}$	-	-	V
			$V_{CC(A)}=2.3\text{V}$ to 2.7V	1.6	-	-	V
			$V_{CC(A)}=3.0\text{V}$ to 3.6V	2	-	-	V
LOW-level input voltage	V_{IL}	data input	$V_{CCI}=0.8\text{V}$	-	-	$0.30V_{CCI}$	V
			$V_{CCI}=1.1\text{V}$ to 1.95V	-	-	$0.35V_{CCI}$	V
			$V_{CCI}=2.3\text{V}$ to 2.7V	-	-	0.7	V
			$V_{CCI}=3.0\text{V}$ to 3.6V	-	-	0.8	V
		nDIR, nOE input	$V_{CC(A)}=0.8\text{V}$	-	-	$0.30V_{CC(A)}$	V
			$V_{CC(A)}=1.1\text{V}$ to 1.95V	-	-	$0.35V_{CC(A)}$	V
			$V_{CC(A)}=2.3\text{V}$ to 2.7V	-	-	0.7	V
			$V_{CC(A)}=3.0\text{V}$ to 3.6V	-	-	0.8	V
HIGH-level output voltage	V_{OH}	$V_I=V_{IH}$ or V_{IL}	$I_O=-100\mu\text{A}; V_{CC(A)}=V_{CC(B)}=0.8\text{V}$ to 3.6V	$V_{CCO}-0.1$	-	-	V
			$I_O=-3\text{mA}; V_{CC(A)}=V_{CC(B)}=1.1\text{V}$	0.85	-	-	V
			$I_O=-6\text{mA}; V_{CC(A)}=V_{CC(B)}=1.4\text{V}$	1.05	-	-	V
			$I_O=-8\text{mA}; V_{CC(A)}=V_{CC(B)}=1.65\text{V}$	1.2	-	-	V
			$I_O=-9\text{mA}; V_{CC(A)}=V_{CC(B)}=2.3\text{V}$	1.75	-	-	V
			$I_O=-12\text{mA}; V_{CC(A)}=V_{CC(B)}=3.0\text{V}$	2.3	-	-	V
LOW-level output voltage	V_{OL}	$V_I=V_{IH}$ or V_{IL}	$I_O=100\mu\text{A}; V_{CC(A)}=V_{CC(B)}=0.8\text{V}$ to 3.6V	-	-	0.1	V
			$I_O=3\text{mA}; V_{CC(A)}=V_{CC(B)}=1.1\text{V}$	-	-	0.25	V
			$I_O=6\text{mA}; V_{CC(A)}=V_{CC(B)}=1.4\text{V}$	-	-	0.35	V
			$I_O=8\text{mA}; V_{CC(A)}=V_{CC(B)}=1.65\text{V}$	-	-	0.45	V
			$I_O=9\text{mA}; V_{CC(A)}=V_{CC(B)}=2.3\text{V}$	-	-	0.55	V
			$I_O=12\text{mA}; V_{CC(A)}=V_{CC(B)}=3.0\text{V}$	-	-	0.7	V
input leakage current	I_I	nDIR, nOE input; $V_I=0\text{V}$ or $3.6\text{V}; V_{CC(A)}=V_{CC(B)}=0.8\text{V}$ to 3.6V	-	-	± 1	μA	



OFF-state output current	I _{OZ}	A or B port; V _O =0V or V _{CCO} ; V _{CC(A)} =V _{CC(B)} =3.6V ^[3]		-	-	±5	uA
		suspend mode A port; V _O =0V or V _{CCO} ; V _{CC(A)} =3.6V; V _{CC(B)} =0V ^[3]		-	-	±5	uA
		suspend mode B port; V _O =0V or V _{CCO} ; V _{CC(A)} =0V; V _{CC(B)} =3.6V ^[3]		-	-	±5	uA
power-off leakage current	I _{OFF}	A port; V _I or V _O =0V to 3.6V; V _{CC(A)} =0V; V _{CC(B)} =0.8V to 3.6V		-	-	±5	uA
		B port; V _I or V _O =0V to 3.6V; V _{CC(B)} =0V; V _{CC(A)} =0.8V to 3.6V		-	-	±5	uA
supply current	I _{CC}	A port; V _I =0V or V _{CCI} ; I _O =0A	V _{CC(A)} =0.8V to 3.6V; V _{CC(B)} =0.8V to 3.6V	-	-	10	uA
			V _{CC(A)} =1.1V to 3.6V; V _{CC(B)} =1.1V to 3.6V	-	-	8	uA
			V _{CC(A)} =3.6V; V _{CC(B)} =0V	-	-	8	uA
			V _{CC(A)} =0V; V _{CC(B)} =3.6V	-2	-	-	uA
	I _{CC}	B port; V _I =0V or V _{CCI} ; I _O =0A	V _{CC(A)} =0.8V to 3.6V; V _{CC(B)} =0.8V to 3.6V	-	-	10	uA
			V _{CC(A)} =1.1V to 3.6V; V _{CC(B)} =1.1V to 3.6V	-	-	8	uA
			V _{CC(A)} =3.6V; V _{CC(B)} =0V	-2	-	-	uA
			V _{CC(A)} =0V; V _{CC(B)} =3.6V	-	-	8	uA
	A plus B port (I _{CC(A)} +I _{CC(B)}); I _O =0A; V _I =0V or V _{CCI} ; V _{CC(A)} =0.8V to 3.6V; V _{CC(B)} =0.8V to 3.6V		-	-	20	uA	
	A plus B port (I _{CC(A)} +I _{CC(B)}); I _O =0A; V _I =0V or V _{CCI} ; V _{CC(A)} =1.1V to 3.6V; V _{CC(B)} =1.1V to 3.6V		-	-	16	uA	

Note:

[1] V_{CCO} is the supply voltage associated with the output port.

[2] V_{CCI} is the supply voltage associated with the data input port.

[3] For I/O ports, the parameter I_{OZ} includes the input leakage current.



3.3.3、DC Characteristics 3

($T_{amb}=-40^{\circ}\text{C}$ to $+125^{\circ}\text{C}$, voltages are referenced to GND (ground=0V), unless otherwise specified)^{[1][2]}

Parameter	Symbol	Conditions	Min.	Typ.	Max.	Unit	
HIGH-level input voltage	V_{IH}	data input	$V_{CCI}=0.8\text{V}$	$0.70V_{CCI}$	-	-	V
			$V_{CCI}=1.1\text{V}$ to 1.95V	$0.65V_{CCI}$	-	-	V
			$V_{CCI}=2.3\text{V}$ to 2.7V	1.6	-	-	V
			$V_{CCI}=3.0\text{V}$ to 3.6V	2	-	-	V
		nDIR, nOE input	$V_{CC(A)}=0.8\text{V}$	$0.70V_{CC(A)}$	-	-	V
			$V_{CC(A)}=1.1\text{V}$ to 1.95V	$0.65V_{CC(A)}$	-	-	V
			$V_{CC(A)}=2.3\text{V}$ to 2.7V	1.6	-	-	V
		$V_{CC(A)}=3.0\text{V}$ to 3.6V	2	-	-	V	
LOW-level input voltage	V_{IL}	data input	$V_{CCI}=0.8\text{V}$	-	-	$0.30V_{CCI}$	V
			$V_{CCI}=1.1\text{V}$ to 1.95V	-	-	$0.35V_{CCI}$	V
			$V_{CCI}=2.3\text{V}$ to 2.7V	-	-	0.7	V
			$V_{CCI}=3.0\text{V}$ to 3.6V	-	-	0.8	V
		nDIR, nOE input	$V_{CC(A)}=0.8\text{V}$	-	-	$0.30V_{CC(A)}$	V
			$V_{CC(A)}=1.1\text{V}$ to 1.95V	-	-	$0.35V_{CC(A)}$	V
			$V_{CC(A)}=2.3\text{V}$ to 2.7V	-	-	0.7	V
		$V_{CC(A)}=3.0\text{V}$ to 3.6V	-	-	0.8	V	
HIGH-level output voltage	V_{OH}	$V_I=V_{IH}$ or V_{IL}	$I_O=-100\mu\text{A}; V_{CC(A)}=V_{CC(B)}=0.8\text{V}$ to 3.6V	$V_{CCO}-0.1$	-	-	V
			$I_O=-3\text{mA}; V_{CC(A)}=V_{CC(B)}=1.1\text{V}$	0.85	-	-	V
			$I_O=-6\text{mA}; V_{CC(A)}=V_{CC(B)}=1.4\text{V}$	1.05	-	-	V
			$I_O=-8\text{mA}; V_{CC(A)}=V_{CC(B)}=1.65\text{V}$	1.2	-	-	V
			$I_O=-9\text{mA}; V_{CC(A)}=V_{CC(B)}=2.3\text{V}$	1.75	-	-	V
			$I_O=-12\text{mA}; V_{CC(A)}=V_{CC(B)}=3.0\text{V}$	2.3	-	-	V
LOW-level output voltage	V_{OL}	$V_I=V_{IH}$ or V_{IL}	$I_O=100\mu\text{A}; V_{CC(A)}=V_{CC(B)}=0.8\text{V}$ to 3.6V	-	-	0.1	V
			$I_O=3\text{mA}; V_{CC(A)}=V_{CC(B)}=1.1\text{V}$	-	-	0.25	V
			$I_O=6\text{mA}; V_{CC(A)}=V_{CC(B)}=1.4\text{V}$	-	-	0.35	V
			$I_O=8\text{mA}; V_{CC(A)}=V_{CC(B)}=1.65\text{V}$	-	-	0.45	V
			$I_O=9\text{mA}; V_{CC(A)}=V_{CC(B)}=2.3\text{V}$	-	-	0.55	V
			$I_O=12\text{mA}; V_{CC(A)}=V_{CC(B)}=3.0\text{V}$	-	-	0.7	V
input leakage current	I_I	nDIR, nOE input; $V_I=0\text{V}$ or $3.6\text{V}; V_{CC(A)}=V_{CC(B)}=0.8\text{V}$ to 3.6V	-	-	± 5	μA	



OFF-state output current	I _{OZ}	A or B port; V _O =0V or V _{CCO} ; V _{CC(A)} =V _{CC(B)} =3.6V ^[3]		-	-	±30	uA
		suspend mode A port; V _O =0V or V _{CCO} ; V _{CC(A)} =3.6V; V _{CC(B)} =0V ^[3]		-	-	±30	uA
		suspend mode B port; V _O =0V or V _{CCO} ; V _{CC(A)} =0V; V _{CC(B)} =3.6V ^[3]		-	-	±30	uA
power-off leakage current	I _{OFF}	A port; V _I or V _O =0V to 3.6V; V _{CC(A)} =0V; V _{CC(B)} =0.8V to 3.6V		-	-	±30	uA
		B port; V _I or V _O =0V to 3.6V; V _{CC(B)} =0V; V _{CC(A)} =0.8V to 3.6V		-	-	±30	uA
supply current	I _{CC}	A port; V _I =0V or V _{CCI} ; I _O =0A	V _{CC(A)} =0.8V to 3.6V; V _{CC(B)} =0.8V to 3.6V	-	-	55	uA
			V _{CC(A)} =1.1V to 3.6V; V _{CC(B)} =1.1V to 3.6V	-	-	50	uA
			V _{CC(A)} =3.6V; V _{CC(B)} =0V	-	-	50	uA
			V _{CC(A)} =0V; V _{CC(B)} =3.6V	-12	-	-	uA
	I _{CC}	B port; V _I =0V or V _{CCI} ; I _O =0A	V _{CC(A)} =0.8V to 3.6V; V _{CC(B)} =0.8V to 3.6V	-	-	55	uA
			V _{CC(A)} =1.1V to 3.6V; V _{CC(B)} =1.1V to 3.6V	-	-	50	uA
			V _{CC(A)} =3.6V; V _{CC(B)} =0V	-12	-	-	uA
			V _{CC(A)} =0V; V _{CC(B)} =3.6V	-	-	50	uA
	A plus B port (I _{CC(A)} +I _{CC(B)}); I _O =0A; V _I =0V or V _{CCI} ; V _{CC(A)} =0.8V to 3.6V; V _{CC(B)} =0.8V to 3.6V		-	-	70	uA	
	A plus B port (I _{CC(A)} +I _{CC(B)}); I _O =0A; V _I =0V or V _{CCI} ; V _{CC(A)} =1.1V to 3.6V; V _{CC(B)} =1.1V to 3.6V		-	-	65	uA	

Note:

[1] V_{CCO} is the supply voltage associated with the output port.

[2] V_{CCI} is the supply voltage associated with the data input port.

[3] For I/O ports, the parameter I_{OZ} includes the input leakage current.

**Typical total supply current ($I_{CC(A)}+I_{CC(B)}$)**

$V_{CC(A)}$	$V_{CC(B)}$							Unit
	0V	0.8V	1.2V	1.5V	1.8V	2.5V	3.3V	
0V	0	0.1	0.1	0.1	0.1	0.1	0.1	uA
0.8V	0.1	0.1	0.1	0.1	0.1	0.3	1.6	uA
1.2V	0.1	0.1	0.1	0.1	0.1	0.1	0.8	uA
1.5V	0.1	0.1	0.1	0.1	0.1	0.1	0.4	uA
1.8V	0.1	0.1	0.1	0.1	0.1	0.1	0.2	uA
2.5V	0.1	0.3	0.1	0.1	0.1	0.1	0.1	uA
3.3V	0.1	1.6	0.8	0.4	0.2	0.1	0.1	uA

3.3.4、AC Characteristics 1

($T_{amb}=25^{\circ}C$, $V_{CC(A)}=V_{CC(B)}$, voltages are referenced to GND (ground=0V), unless otherwise specified)^{[1][2]}

Parameter	Symbol	Conditions	$V_{CC(A)}=V_{CC(B)}$						Unit
			0.8V	1.2V	1.5V	1.8V	2.5V	3.3V	
power dissipation capacitance	C_{PD}	A port: (direction nAn to nBn); output enabled	0.2	0.2	0.2	0.2	0.3	0.4	pF
		A port: (direction nAn to nBn); output disabled	0.2	0.2	0.2	0.2	0.3	0.4	pF
		A port: (direction nBn to nAn); output enabled	9.5	9.7	9.8	9.9	10.7	11.9	pF
		A port: (direction nBn to nAn); output disabled	0.6	0.6	0.6	0.6	0.7	0.7	pF
		B port: (direction nAn to nBn); output enabled	9.5	9.7	9.8	9.9	10.7	11.9	pF
		B port: (direction nAn to nBn); output disabled	0.6	0.6	0.6	0.6	0.7	0.7	pF
		B port: (direction nBn to nAn); output enabled	0.2	0.2	0.2	0.2	0.3	0.4	pF
		B port: (direction nBn to nAn); output disabled	0.2	0.2	0.2	0.2	0.3	0.4	pF

Note:

[1] C_{PD} is used to determine the dynamic power dissipation (P_D in uW).

$P_D=C_{PD} \times V_{CC}^2 \times f_i \times N + \Sigma(C_L \times V_{CC}^2 \times f_o)$ where:

f_i =input frequency in MHz;

f_o =output frequency in MHz;

C_L =load capacitance in pF;

V_{CC} =supply voltage in V;

N =number of inputs switching;

$\Sigma(C_L \times V_{CC}^2 \times f_o)$ =sum of the outputs.

[2] $f_i=10MHz$; $V_I=GND$ to V_{CC} ; $t_r=t_f=1ns$; $C_L=0pF$; $R_L=\infty\Omega$.



3.3.5、AC Characteristics 2

($T_{amb}=25^{\circ}\text{C}$, $V_{CC(A)}=0.8\text{V}$, voltages are referenced to GND (ground=0V), unless otherwise specified)^[1]

Parameter	Symbol	Conditions	$V_{CC(B)}$						Unit
			0.8V	1.2V	1.5V	1.8V	2.5V	3.3V	
propagation delay	t_{pd}	nAn to nBn	14.5	7.3	6.5	6.2	5.9	6.0	ns
		nBn to nAn	14.5	12.7	12.4	12.3	12.1	12.0	ns
disable time	t_{dis}	$\overline{\text{nOE}}$ to nAn	14.3	14.3	14.3	14.3	14.3	14.3	ns
		$\overline{\text{nOE}}$ to nBn	17.0	9.9	9.0	9.4	9.0	9.7	ns
enable time	t_{en}	$\overline{\text{nOE}}$ to nAn	18.2	18.2	18.2	18.2	18.2	18.2	ns
		$\overline{\text{nOE}}$ to nBn	19.2	10.7	9.8	9.6	9.7	10.2	ns

Note:

[1] t_{pd} is the same as t_{PLH} and t_{PHL} ; t_{dis} is the same as t_{PLZ} and t_{PHZ} ; t_{en} is the same as t_{PZL} and t_{PZH} .

3.3.6、AC Characteristics 3

($T_{amb}=25^{\circ}\text{C}$, $V_{CC(B)}=0.8\text{V}$, voltages are referenced to GND (ground=0V), unless otherwise specified)^[1]

Parameter	Symbol	Conditions	$V_{CC(A)}$						Unit
			0.8V	1.2V	1.5V	1.8V	2.5V	3.3V	
propagation delay	t_{pd}	nAn to nBn	14.5	12.7	12.4	12.3	12.1	12.0	ns
		nBn to nAn	14.5	7.3	6.5	6.2	5.9	6.0	ns
disable time	t_{dis}	$\overline{\text{nOE}}$ to nAn	14.3	5.5	4.1	4.0	3.0	3.5	ns
		$\overline{\text{nOE}}$ to nBn	17.0	13.8	13.4	13.1	12.9	12.7	ns
enable time	t_{en}	$\overline{\text{nOE}}$ to nAn	18.2	5.6	4.0	3.2	2.4	2.2	ns
		$\overline{\text{nOE}}$ to nBn	19.2	14.6	14.1	13.9	13.7	13.6	ns

Note:

[1] t_{pd} is the same as t_{PLH} and t_{PHL} ; t_{dis} is the same as t_{PLZ} and t_{PHZ} ; t_{en} is the same as t_{PZL} and t_{PZH} .



3.3.7、AC Characteristics 4

(T_{amb}=-40°C to +85°C, voltages are referenced to GND (ground=0V), unless otherwise specified)^[1]

Parameter	Symbol	Conditions	V _{CC(B)}										Unit
			1.2V±0.1V		1.5V±0.1V		1.8V±0.15V		2.5V±0.2V		3.3V±0.3V		
			Min.	Max.	Min.	Max.	Min.	Max.	Min.	Max.	Min.	Max.	
V_{CC(A)}=1.1V to 1.3V													
propagation delay	t _{pd}	nAn to nBn	0.5	9.4	0.5	7.1	0.5	6.2	0.5	5.2	0.5	5.1	ns
		nBn to nAn	0.5	9.4	0.5	8.9	0.5	8.7	0.5	8.4	0.5	8.2	ns
disable time	t _{dis}	n $\overline{\text{OE}}$ to nAn	1.8	10.9	1.8	10.9	1.8	10.9	1.8	10.9	1.8	10.9	ns
		n $\overline{\text{OE}}$ to nBn	1.9	12.4	1.9	9.6	1.9	9.5	1.4	8.1	1.2	9.1	ns
enable time	t _{en}	n $\overline{\text{OE}}$ to nAn	1.4	12.8	1.4	12.8	1.4	12.8	1.4	12.8	1.4	12.8	ns
		n $\overline{\text{OE}}$ to nBn	1.1	13.3	1.1	10.0	1.1	8.9	1.0	7.9	1.0	7.7	ns
V_{CC(A)}=1.4V to 1.6V													
propagation delay	t _{pd}	nAn to nBn	0.3	8.9	0.3	6.3	0.3	5.2	0.3	4.2	0.3	4.2	ns
		nBn to nAn	0.7	7.1	0.7	6.3	0.5	6.0	0.4	5.7	0.3	5.6	ns
disable time	t _{dis}	n $\overline{\text{OE}}$ to nAn	1.8	10.2	1.8	10.2	1.5	10.2	1.3	10.2	1.6	10.2	ns
		n $\overline{\text{OE}}$ to nBn	1.9	11.3	1.9	10.3	1.9	9.1	1.4	7.4	1.2	7.6	ns
enable time	t _{en}	n $\overline{\text{OE}}$ to nAn	1.1	9.4	1.4	9.4	1.1	9.4	0.7	9.4	0.4	9.4	ns
		n $\overline{\text{OE}}$ to nBn	1.4	12.1	1.4	9.6	1.1	7.7	0.9	5.8	0.9	5.6	ns
V_{CC(A)}=1.65V to 1.95V													
propagation delay	t _{pd}	nAn to nBn	0.1	8.7	0.1	6.0	0.1	4.9	0.1	3.9	0.3	3.9	ns
		nBn to nAn	0.6	6.2	0.6	5.3	0.5	4.9	0.3	4.6	0.3	4.5	ns
disable time	t _{dis}	n $\overline{\text{OE}}$ to nAn	1.8	8.6	1.6	8.6	1.8	8.6	1.3	8.6	1.6	8.6	ns
		n $\overline{\text{OE}}$ to nBn	1.7	10.9	1.7	9.9	1.6	8.7	1.2	6.9	1.0	6.9	ns
enable time	t _{en}	n $\overline{\text{OE}}$ to nAn	1.0	7.2	1.0	7.2	1.0	7.2	0.6	7.2	0.4	7.2	ns
		n $\overline{\text{OE}}$ to nBn	1.2	11.7	1.2	9.2	1.0	7.4	0.8	5.3	0.8	4.6	ns
V_{CC(A)}=2.3V to 2.7V													
propagation delay	t _{pd}	nAn to nBn	0.1	8.4	0.1	5.7	0.1	4.6	0.2	3.5	0.1	3.6	ns
		nBn to nAn	0.6	5.2	0.6	4.2	0.4	3.9	0.2	3.4	0.2	3.3	ns
disable time	t _{dis}	n $\overline{\text{OE}}$ to nAn	1.0	6.2	1.0	6.2	1.0	6.2	1.0	6.2	1.0	6.2	ns
		n $\overline{\text{OE}}$ to nBn	1.5	10.4	1.5	8.8	1.3	8.2	1.1	6.2	0.9	5.2	ns
enable time	t _{en}	n $\overline{\text{OE}}$ to nAn	0.7	4.8	0.7	4.8	0.7	4.8	0.6	4.8	0.4	4.8	ns
		n $\overline{\text{OE}}$ to nBn	0.9	11.3	0.9	8.8	0.8	7.0	0.6	4.8	0.6	4.0	ns
V_{CC(A)}=3.0V to 3.6V													
propagation delay	t _{pd}	nAn to nBn	0.1	8.2	0.1	5.6	0.1	4.5	0.1	3.3	0.1	2.9	ns
		nBn to nAn	0.6	5.1	0.6	4.2	0.4	3.4	0.2	3.0	0.1	2.8	ns
disable time	t _{dis}	n $\overline{\text{OE}}$ to nAn	0.7	5.6	0.7	5.6	0.7	5.6	0.7	5.6	0.7	5.6	ns
		n $\overline{\text{OE}}$ to nBn	1.4	10.2	1.4	9.3	1.2	8.1	1.0	6.4	0.8	6.2	ns
enable time	t _{en}	n $\overline{\text{OE}}$ to nAn	0.6	3.8	0.6	3.8	0.6	3.8	0.6	3.8	0.4	3.8	ns
		n $\overline{\text{OE}}$ to nBn	0.8	11.3	0.8	8.7	0.6	6.8	0.5	4.7	0.5	3.8	ns

Note:

[1] t_{pd} is the same as t_{PLH} and t_{PHL}; t_{dis} is the same as t_{PLZ} and t_{PHZ}; t_{en} is the same as t_{PZL} and t_{PZH}.



3.3.8、AC Characteristics 5

($T_{amb} = -40^{\circ}\text{C}$ to $+125^{\circ}\text{C}$, voltages are referenced to GND (ground=0V), unless otherwise specified)^[1]

Parameter	Symbol	Conditions	$V_{CC(B)}$										Unit
			1.2V±0.1V		1.5V±0.1V		1.8V±0.15V		2.5V±0.2V		3.3V±0.3V		
			Min.	Max.	Min.	Max.	Min.	Max.	Min.	Max.	Min.	Max.	
$V_{CC(A)}=1.1\text{V to }1.3\text{V}$													
propagation delay	t_{pd}	nAn to nBn	0.5	10.4	0.5	7.9	0.5	6.9	0.5	5.8	0.5	5.7	ns
		nBn to nAn	0.5	10.4	0.5	9.8	0.5	9.6	0.5	9.3	0.5	9.1	ns
disable time	t_{dis}	$\overline{\text{nOE}}$ to nAn	1.8	12.0	1.8	12.0	1.8	12.0	1.8	12.0	1.8	12.0	ns
		$\overline{\text{nOE}}$ to nBn	1.9	13.7	1.9	10.6	1.9	10.5	1.4	9.0	1.2	10.1	ns
enable time	t_{en}	$\overline{\text{nOE}}$ to nAn	1.4	14.1	1.4	14.1	1.4	14.1	1.4	14.1	1.4	14.1	ns
		$\overline{\text{nOE}}$ to nBn	1.1	14.7	1.1	11.0	1.1	9.8	1.0	8.7	1.0	8.5	ns
$V_{CC(A)}=1.4\text{V to }1.6\text{V}$													
propagation delay	t_{pd}	nAn to nBn	0.3	9.8	0.3	7.0	0.3	5.8	0.3	4.7	0.3	4.7	ns
		nBn to nAn	0.7	7.9	0.7	7.0	0.5	6.6	0.4	6.3	0.3	6.2	ns
disable time	t_{dis}	$\overline{\text{nOE}}$ to nAn	1.8	11.3	1.8	11.3	1.5	11.3	1.3	11.3	1.6	11.3	ns
		$\overline{\text{nOE}}$ to nBn	1.9	12.5	1.9	11.4	1.9	10.1	1.4	8.2	1.2	8.4	ns
enable time	t_{en}	$\overline{\text{nOE}}$ to nAn	1.1	10.4	1.4	10.4	1.1	10.4	0.7	10.4	0.4	10.4	ns
		$\overline{\text{nOE}}$ to nBn	1.4	13.3	1.4	10.6	1.1	8.5	0.9	6.4	0.9	6.2	ns
$V_{CC(A)}=1.65\text{V to }1.95\text{V}$													
propagation delay	t_{pd}	nAn to nBn	0.1	9.6	0.1	6.6	0.1	5.4	0.1	4.3	0.3	4.3	ns
		nBn to nAn	0.6	6.9	0.6	5.9	0.5	5.4	0.3	5.1	0.3	5.0	ns
disable time	t_{dis}	$\overline{\text{nOE}}$ to nAn	1.8	9.5	1.6	9.5	1.8	9.5	1.3	9.5	1.6	9.5	ns
		$\overline{\text{nOE}}$ to nBn	1.7	12.0	1.7	10.9	1.6	9.6	1.2	7.6	1.0	7.6	ns
enable time	t_{en}	$\overline{\text{nOE}}$ to nAn	1.0	8.0	1.0	8.0	1.0	8.0	0.6	8.0	0.4	8.0	ns
		$\overline{\text{nOE}}$ to nBn	1.2	12.9	1.2	10.2	1.0	8.2	0.8	5.9	0.8	5.1	ns
$V_{CC(A)}=2.3\text{V to }2.7\text{V}$													
propagation delay	t_{pd}	nAn to nBn	0.1	9.3	0.1	6.3	0.1	5.1	0.2	4.0	0.1	4.0	ns
		nBn to nAn	0.6	5.8	0.6	4.7	0.4	4.3	0.2	3.9	0.2	3.8	ns
disable time	t_{dis}	$\overline{\text{nOE}}$ to nAn	1.0	6.9	1.0	6.9	1.0	6.9	1.0	6.9	1.0	6.9	ns
		$\overline{\text{nOE}}$ to nBn	1.5	11.5	1.5	10.4	1.3	9.1	1.1	6.9	0.9	5.8	ns
enable time	t_{en}	$\overline{\text{nOE}}$ to nAn	0.7	5.3	0.7	5.3	0.7	5.3	0.6	5.3	0.4	5.3	ns
		$\overline{\text{nOE}}$ to nBn	0.9	12.4	0.9	9.7	0.8	7.7	0.6	5.3	0.6	4.4	ns
$V_{CC(A)}=3.0\text{V to }3.6\text{V}$													
propagation delay	t_{pd}	nAn to nBn	0.1	9.1	0.1	6.2	0.1	5.0	0.1	3.8	0.1	3.3	ns
		nBn to nAn	0.6	5.7	0.6	4.7	0.4	3.9	0.2	3.4	0.1	3.3	ns
disable time	t_{dis}	$\overline{\text{nOE}}$ to nAn	0.7	6.2	0.7	6.2	0.7	6.2	0.7	6.2	0.7	6.2	ns
		$\overline{\text{nOE}}$ to nBn	1.4	11.3	1.4	10.3	1.2	9.0	1.0	7.1	0.8	6.9	ns
enable time	t_{en}	$\overline{\text{nOE}}$ to nAn	0.6	4.2	0.6	4.2	0.6	4.2	0.6	4.2	0.4	4.2	ns
		$\overline{\text{nOE}}$ to nBn	0.8	12.4	0.8	9.6	0.6	7.5	0.5	5.2	0.5	4.2	ns

Note:

[1] t_{pd} is the same as t_{PLH} and t_{PHL} ; t_{dis} is the same as t_{PLZ} and t_{PHZ} ; t_{en} is the same as t_{PZL} and t_{PZH} .



4、Testing Circuit

4.1、AC Testing Circuit

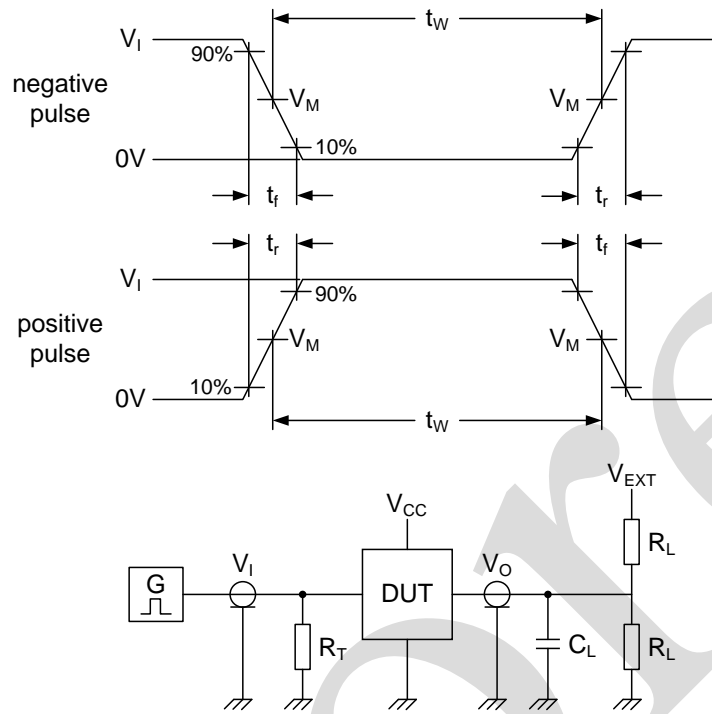

Figure 3. Test circuit for measuring switching times

R_L =Load resistance.

C_L =Load capacitance including jig and probe capacitance.

R_T =Termination resistance.

V_{EXT} =External voltage for measuring switching times.



4.2、AC Testing Waveforms

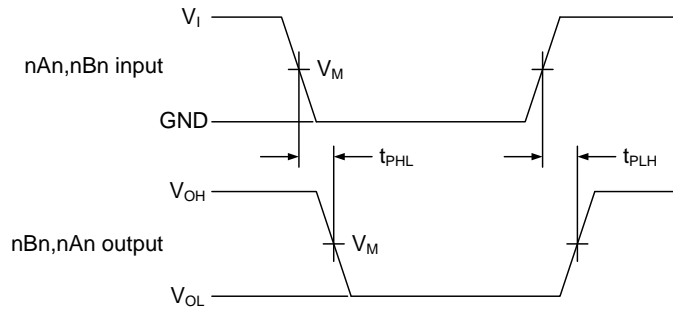

Figure 4. The data input (nAn, nBn) to output (nBn, nAn) propagation delay times

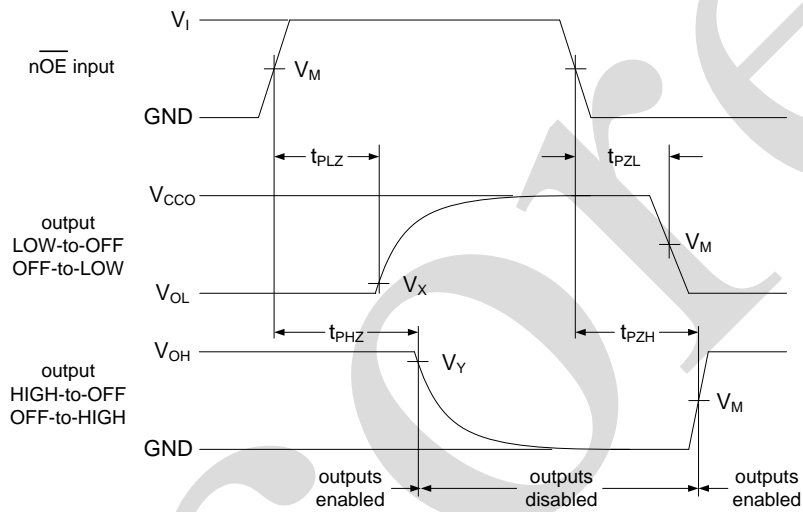

Figure 5. Enable and disable times

4.3、Measurement Points

Supply voltage	Input ^[1]	Output ^[2]		
$V_{CC(A)}, V_{CC(B)}$	V_M	V_M	V_X	V_Y
0.8V to 1.6V	$0.5V_{CCI}$	$0.5V_{CCO}$	$V_{OL}+0.1V$	$V_{OH}-0.1V$
1.65V to 2.7V	$0.5V_{CCI}$	$0.5V_{CCO}$	$V_{OL}+0.15V$	$V_{OH}-0.15V$
3.0V to 3.6V	$0.5V_{CCI}$	$0.5V_{CCO}$	$V_{OL}+0.3V$	$V_{OH}-0.3V$

Note:

[1] V_{CCI} is the supply voltage associated with the data input port.

[2] V_{CCO} is the supply voltage associated with the output port.



4.4、 Test Data

Supply voltage	Input		Load		V_{EXT}		
	$V_{CC(A)}, V_{CC(B)}$	$V_I^{[1]}$	$\Delta t/\Delta V^{[2]}$	C_L	R_L	t_{PLH}, t_{PHL}	t_{PZH}, t_{PHZ}
0.8V to 1.6V	V_{CCI}	$\leq 1.0\text{ns/V}$	15pF	2k Ω	open	GND	$2V_{CCO}$
1.65V to 2.7V	V_{CCI}	$\leq 1.0\text{ns/V}$	15pF	2k Ω	open	GND	$2V_{CCO}$
3.0V to 3.6V	V_{CCI}	$\leq 1.0\text{ns/V}$	15pF	2k Ω	open	GND	$2V_{CCO}$

Note:

[1] V_{CCI} is the supply voltage associated with the data input port.

[2] $dV/dt \geq 1.0\text{V/ns}$

[3] V_{CCO} is the supply voltage associated with the output port.

5、 Characteristic Curve

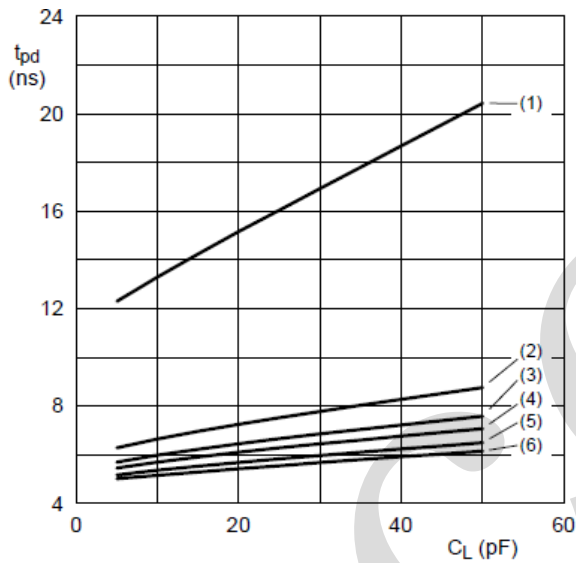

a. Propagation delay (A to B); $V_{CC(A)}=0.8\text{V}$

- (1) $V_{CC(B)}=0.8\text{V}$
- (2) $V_{CC(B)}=1.2\text{V}$
- (3) $V_{CC(B)}=1.5\text{V}$
- (4) $V_{CC(B)}=1.8\text{V}$
- (5) $V_{CC(B)}=2.5\text{V}$
- (6) $V_{CC(B)}=3.3\text{V}$

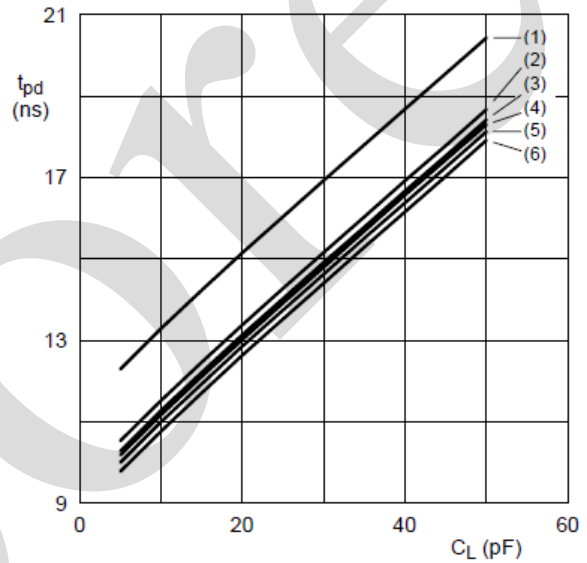

b. Propagation delay (A to B); $V_{CC(B)}=0.8\text{V}$

- (1) $V_{CC(A)}=0.8\text{V}$
- (2) $V_{CC(A)}=1.2\text{V}$
- (3) $V_{CC(A)}=1.5\text{V}$
- (4) $V_{CC(A)}=1.8\text{V}$
- (5) $V_{CC(A)}=2.5\text{V}$
- (6) $V_{CC(A)}=3.3\text{V}$

Figure 6. Typical propagation delay versus load capacitance; $T_{amb}=25^\circ\text{C}$

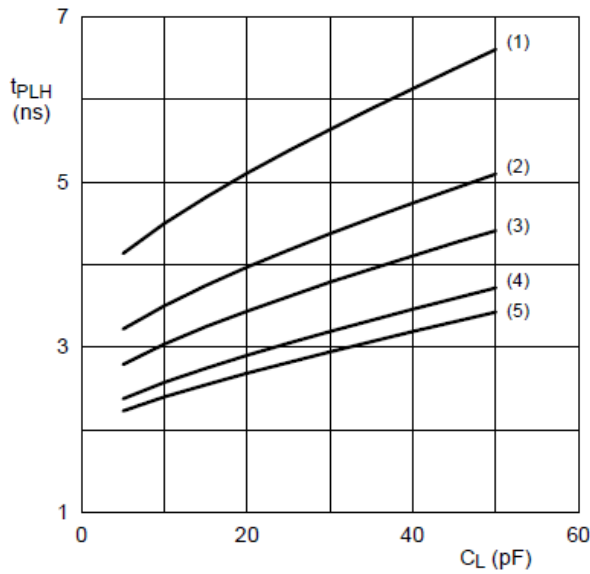

a. LOW to HIGH propagation delay (A to B);
 $V_{CC(A)}=1.2V$

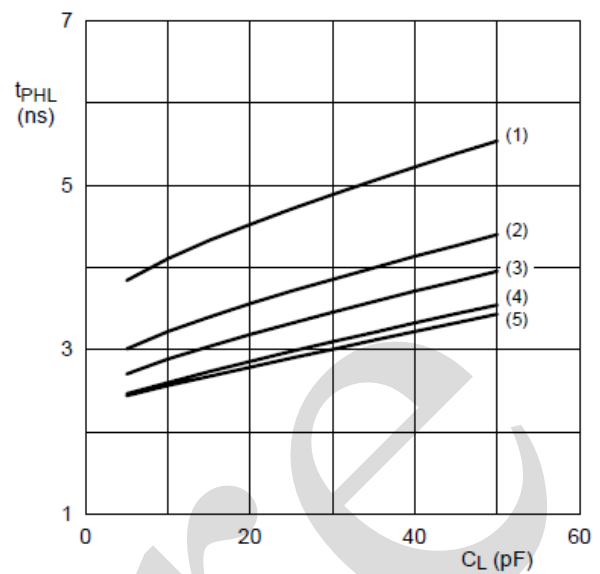

b. HIGH to LOW propagation delay (A to B);
 $V_{CC(A)}=1.2V$

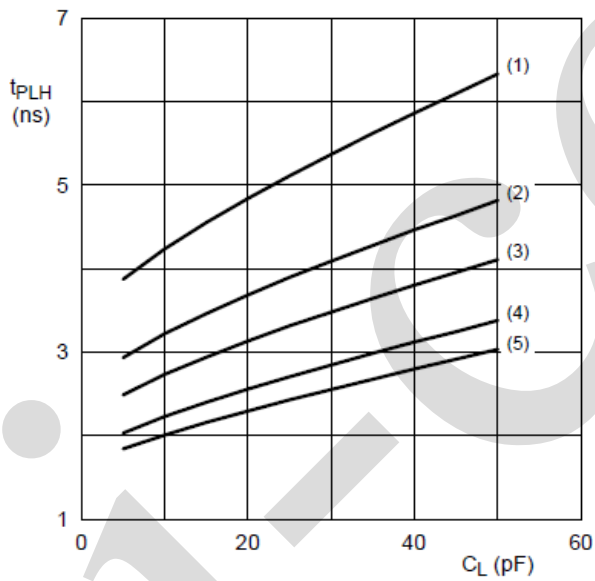

c. LOW to HIGH propagation delay (A to B);
 $V_{CC(A)}=1.5V$
(1) $V_{CC(B)}=1.2V$
(2) $V_{CC(B)}=1.5V$
(3) $V_{CC(B)}=1.8V$
(4) $V_{CC(B)}=2.5V$
(5) $V_{CC(B)}=3.3V$

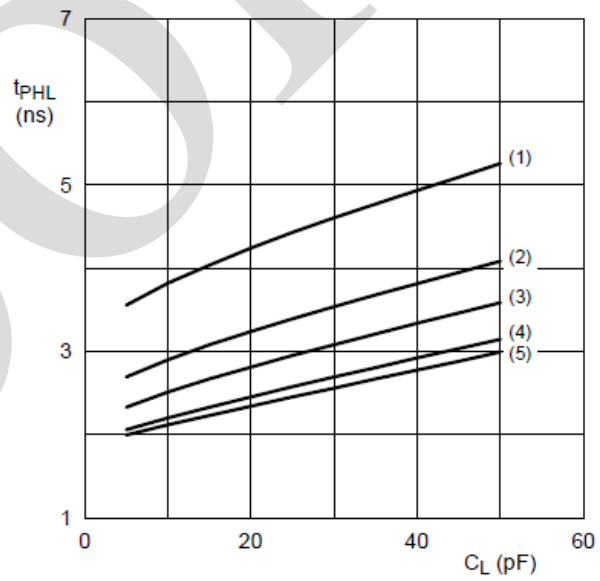

d. HIGH to LOW propagation delay (A to B);
 $V_{CC(A)}=1.5V$

Figure 7. Typical propagation delay versus load capacitance; $T_{amb}=25^{\circ}C$

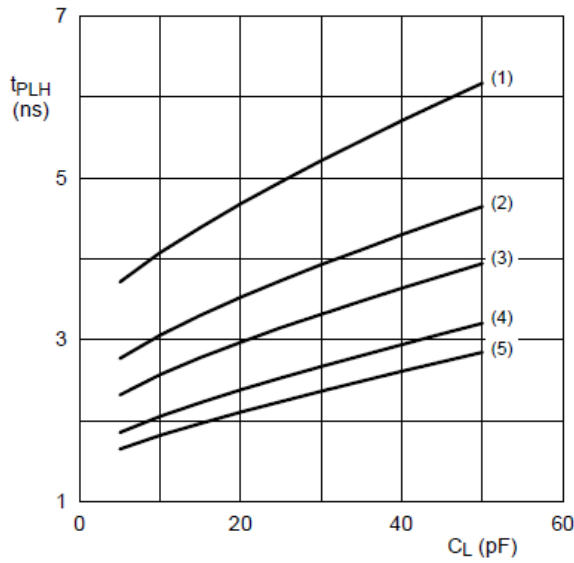

a. LOW to HIGH propagation delay (A to B);
 $V_{CC(A)}=1.8V$

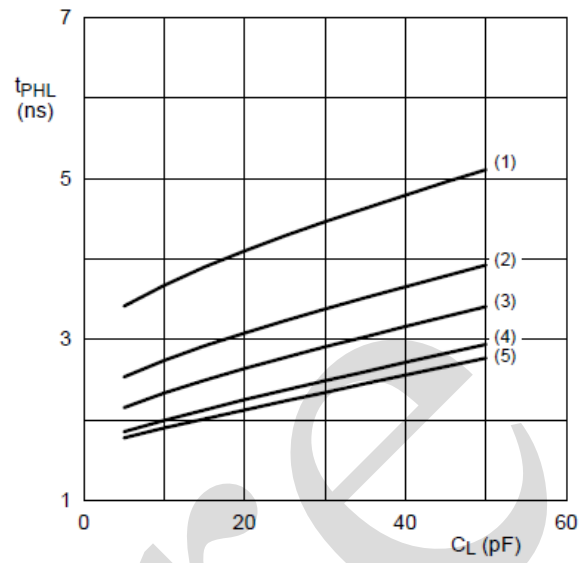

b. HIGH to LOW propagation delay (A to B);
 $V_{CC(A)}=1.8V$

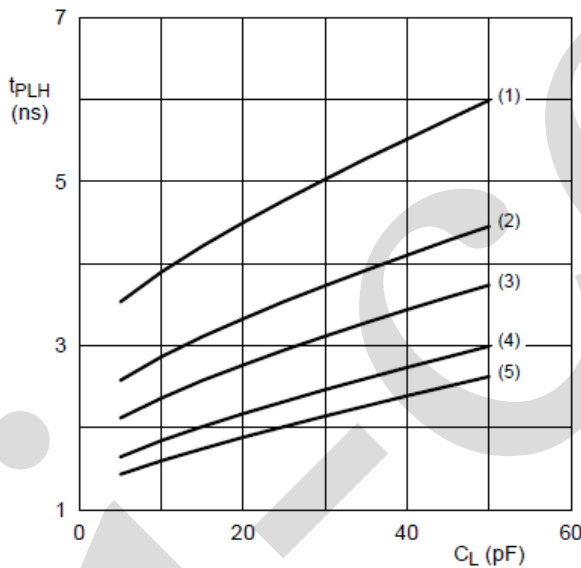

c. LOW to HIGH propagation delay (A to B);
 $V_{CC(A)}=2.5V$
(1) $V_{CC(B)}=1.2V$
(2) $V_{CC(B)}=1.5V$
(3) $V_{CC(B)}=1.8V$
(4) $V_{CC(B)}=2.5V$
(5) $V_{CC(B)}=3.3V$

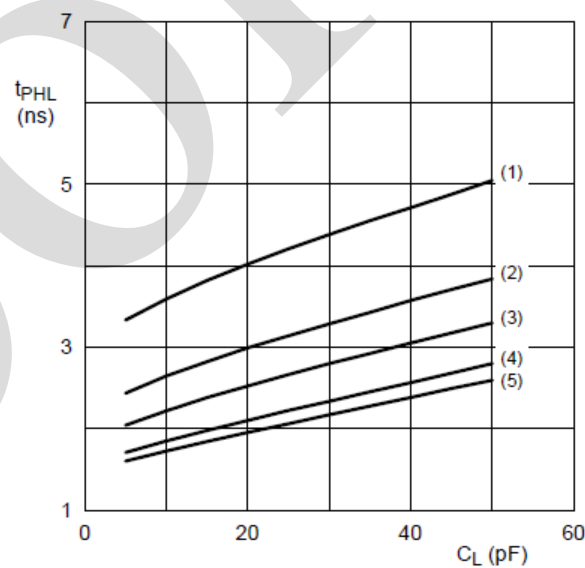

d. HIGH to LOW propagation delay (A to B);
 $V_{CC(A)}=2.5V$

Figure 8. Typical propagation delay versus load capacitance; $T_{amb}=25^{\circ}C$

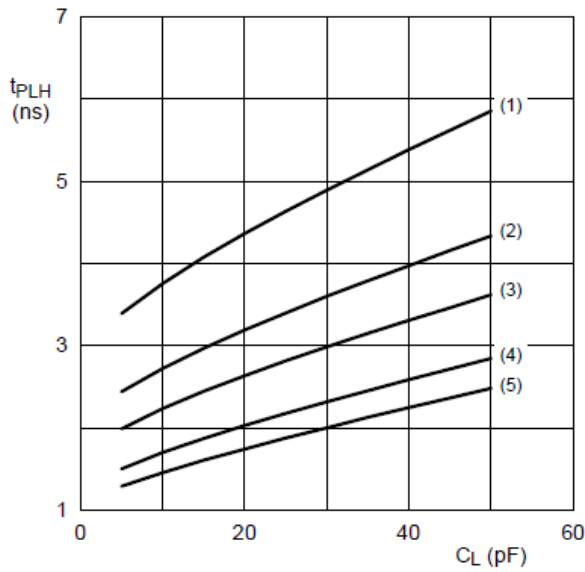

a. LOW to HIGH propagation delay (A to B);

V_{CC(A)}=3.3V

- (1) V_{CC(B)}=1.2V
- (2) V_{CC(B)}=1.5V
- (3) V_{CC(B)}=1.8V
- (4) V_{CC(B)}=2.5V
- (5) V_{CC(B)}=3.3V

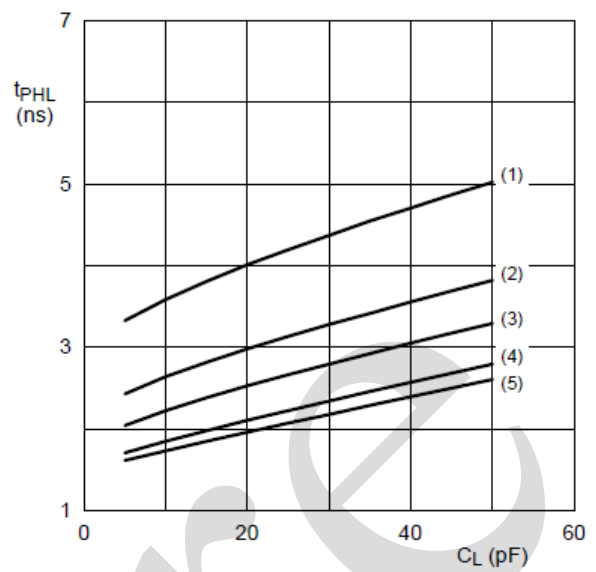

b. HIGH to LOW propagation delay (A to B);

V_{CC(A)}=3.3V

Figure 9. Typical propagation delay versus load capacitance; T_{amb}=25°C



6、Package Information

6.1、SOP16

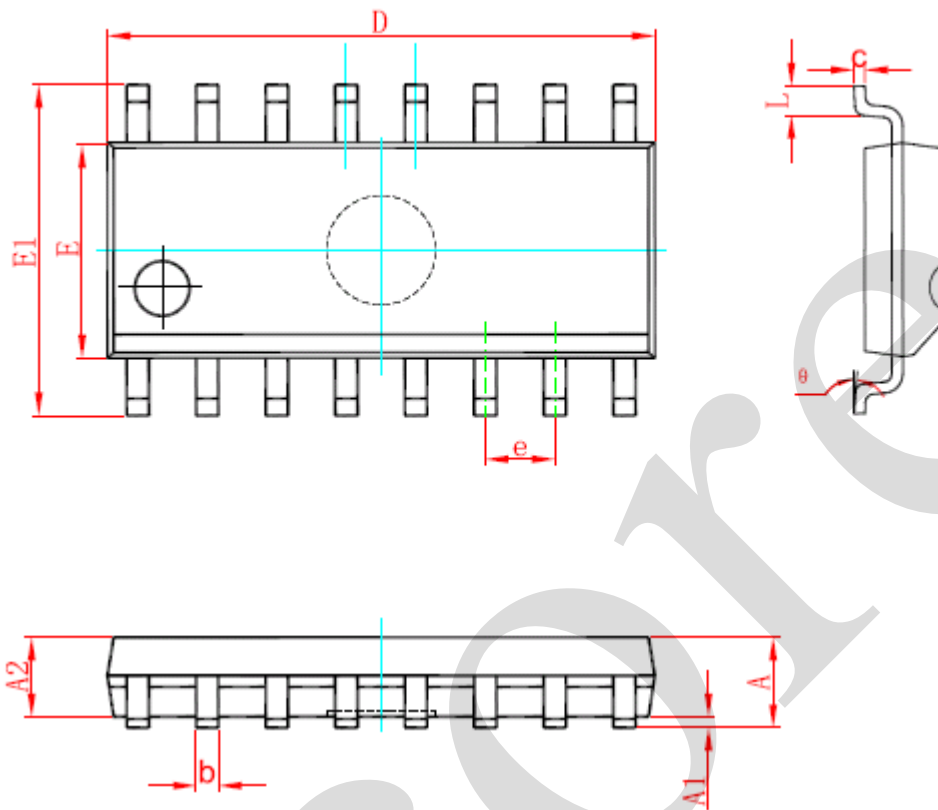

Symbol	Dimensions In Millimeters		Dimensions In Inches	
	Min	Max	Min	Max
A	1.350	1.750	0.053	0.069
A1	0.100	0.250	0.004	0.010
A2	1.350	1.550	0.053	0.061
b	0.330	0.510	0.013	0.020
c	0.170	0.250	0.007	0.010
D	9.800	10.200	0.386	0.402
E	3.800	4.000	0.150	0.157
E1	5.800	6.200	0.228	0.244
e	1.270 (BSC)		0.050 (BSC)	
L	0.400	1.270	0.016	0.050
θ	0°	8°	0°	8°



6.2、TSSOP16

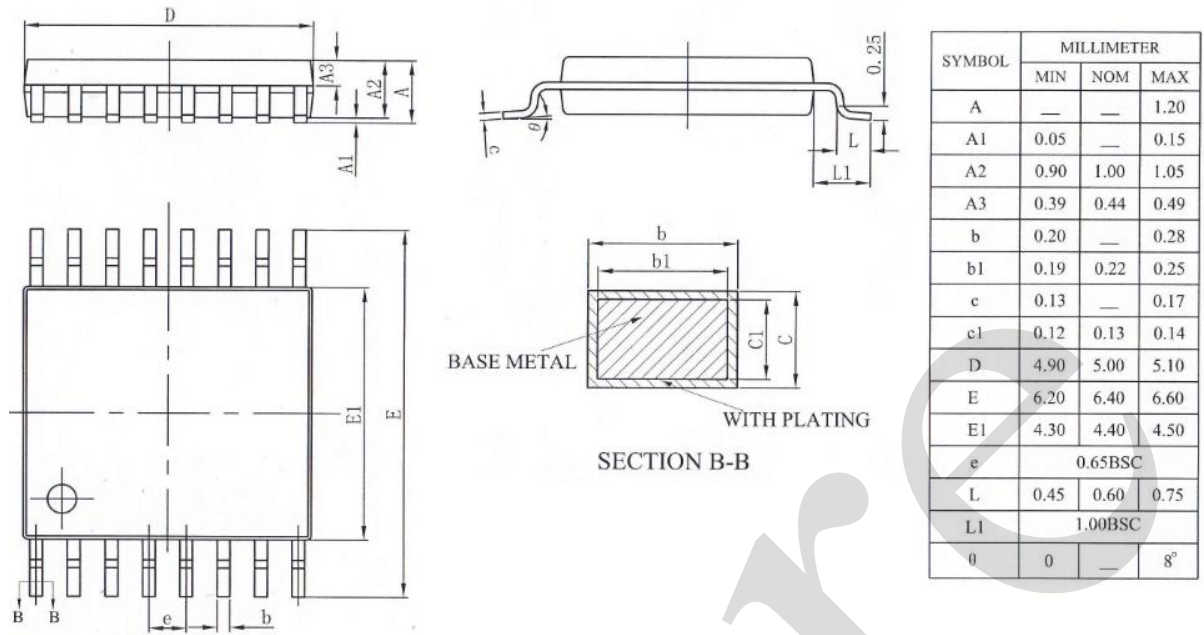



6.3、DHVQFN16

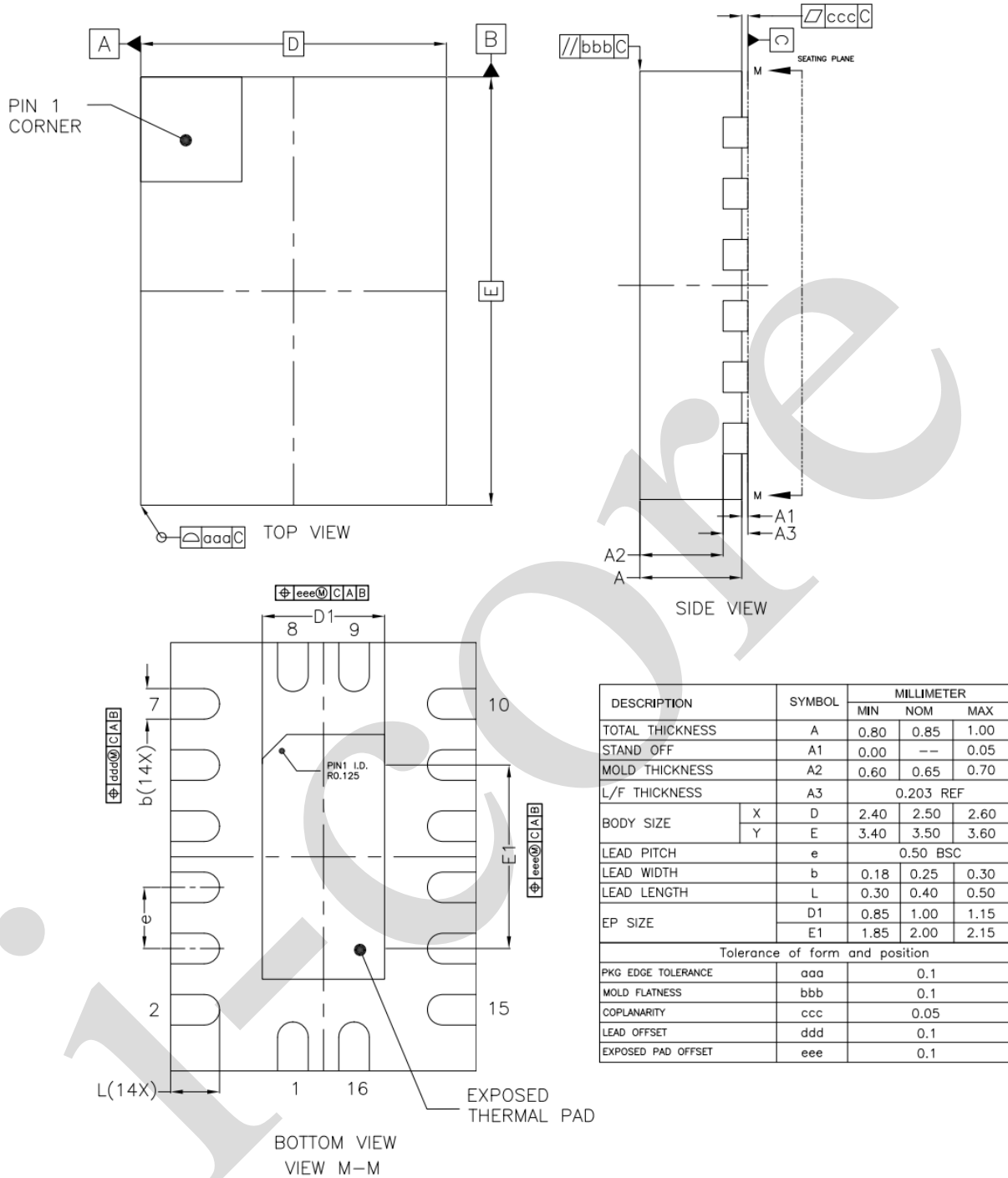

DESCRIPTION	SYMBOL	MILLIMETER		
		MIN	NOM	MAX
TOTAL THICKNESS	A	0.80	0.85	1.00
STAND OFF	A1	0.00	--	0.05
MOLD THICKNESS	A2	0.60	0.65	0.70
L/F THICKNESS	A3	0.203 REF		
BODY SIZE	X	2.40	2.50	2.60
	Y	3.40	3.50	3.60
LEAD PITCH	e	0.50 BSC		
LEAD WIDTH	b	0.18	0.25	0.30
LEAD LENGTH	L	0.30	0.40	0.50
EP SIZE	D1	0.85	1.00	1.15
	E1	1.85	2.00	2.15
Tolerance of form and position				
PKG EDGE TOLERANCE	aaa	0.1		
MOLD FLATNESS	bbb	0.1		
COPLANARITY	ccc	0.05		
LEAD OFFSET	ddd	0.1		
EXPOSED PAD OFFSET	eee	0.1		

NOTES
 1.0 COPLANARITY APPLIES TO LEADS, CORNER LEADS AND DIE ATTACH PAD.



6.4、VQFN16

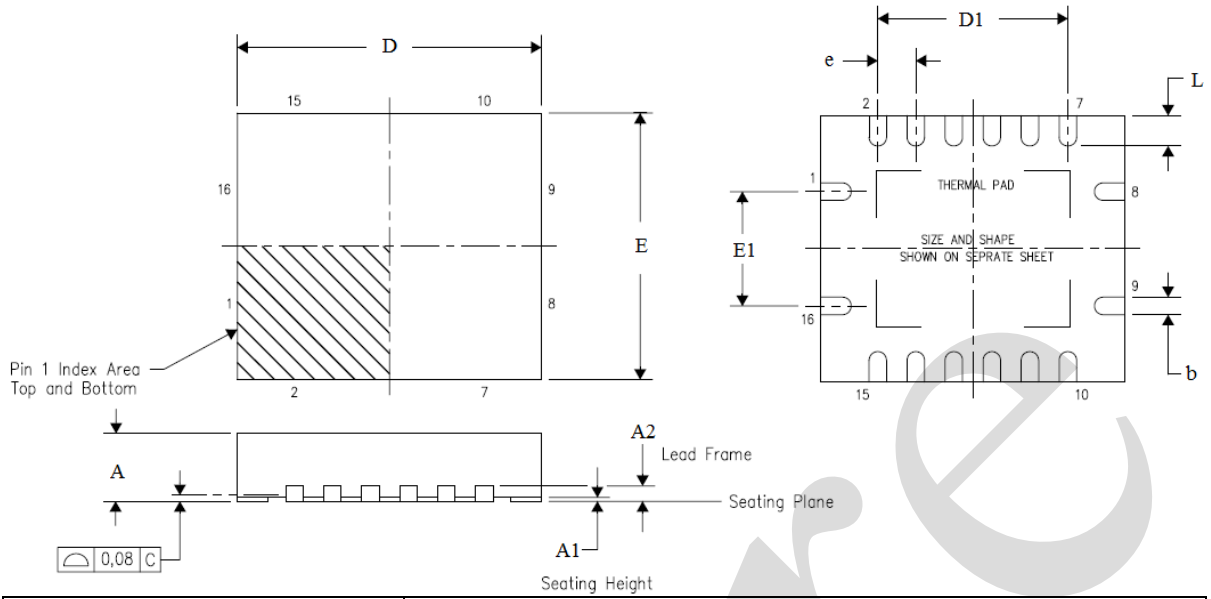

Symbol	Dimensions (mm)	
	Min.	Max.
A	0.80	1.00
A1	0.00	0.05
A2	0.20 (REF)	
D	3.85	4.15
D1	2.50 (REF)	
E	3.35	3.65
E1	1.50 (REF)	
e	0.50 (BSC)	
e1	0.18	0.30
L	0.30	0.50



7、 Statements And Notes

7.1、 The name and content of Hazardous substances or Elements in the product

Part name	Hazardous substances or Elements									
	Lead and lead compounds	Mercury and mercury compounds	Cadmium and cadmium compounds	Hexavalent chromium compounds	Polybrominated biphenyls	Polybrominated biphenyl ethers	Dibutyl phthalate	Butylbenzyl phthalate	Di-2-ethylhexyl phthalate	Diisobutyl phthalate
Lead frame	○	○	○	○	○	○	○	○	○	○
Plastic resin	○	○	○	○	○	○	○	○	○	○
Chip	○	○	○	○	○	○	○	○	○	○
The lead	○	○	○	○	○	○	○	○	○	○
Plastic sheet installed	○	○	○	○	○	○	○	○	○	○
explanation	○: Indicates that the content of hazardous substances or elements in the detection limit of the following the SJ/T11363-2006 standard. ×: Indicates that the content of hazardous substances or elements exceeding the SJ/T11363-2006 Standard limit requirements.									

7.2、 Notes

Recommended carefully reading this information before the use of this product;

The information in this document are subject to change without notice;

This information is using to the reference only, the company is not responsible for any loss;

The company is not responsible for the any infringement of the third party patents or other rights of the responsibility.