



0.8A Step-Up Current Mode PWM Converter ME2159A

Description

The ME2159A is a current mode boost DC-DC converter. Its PWM circuitry with built-in 0.18Ω power MOSFET make this regulator highly power efficient. The internal compensation network also minimizes as much as 6 external component counts. The non-inverting input of error amplifier connects to a 0.6V precision reference voltage and internal soft-start function can reduce the inrush current.

Applications

- Chargers
- LCD Displays
- Digital Cameras
- Handheld Devices
- Portable Products

Features

- Precision Feedback Reference Voltage: 0.6V
- Reference Voltage accuracy: $\pm 2\%$
- Adjustable Output up to 12V
- Internal Fixed PWM frequency: 650KHz
- Internal 0.18Ω, 2A, 16V Power MOSFET
- Shutdown Current: 0.1μA
- Over Temperature Protection: 165°C

Package

- 6-pin SOT23-6

Typical Application

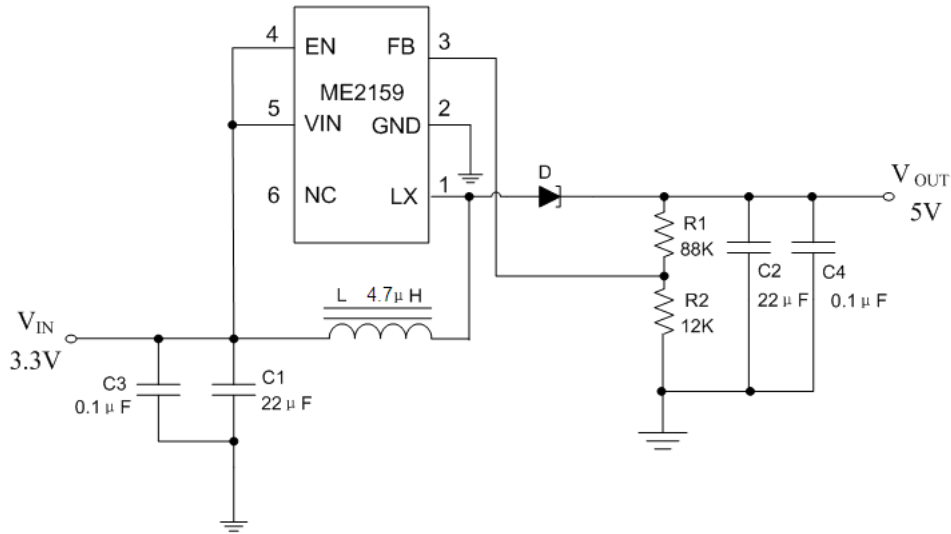

Selection Guide

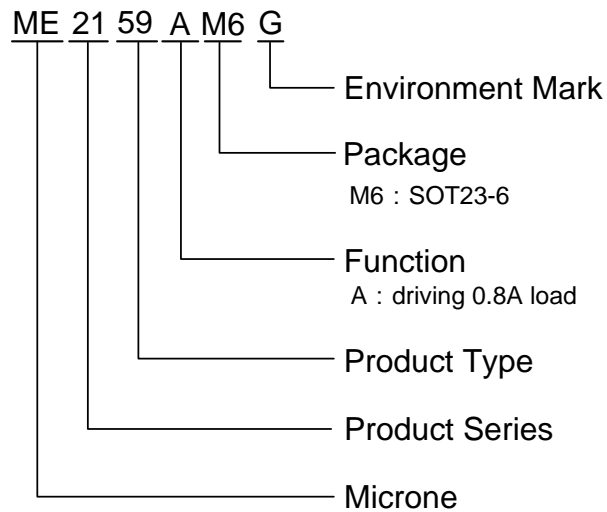

product series	product function	Output voltage	Package
ME2159AM6G	Driving 0.8A Load	$V_{FB}=600\text{mv}$	SOT23-6

Pin Configuration

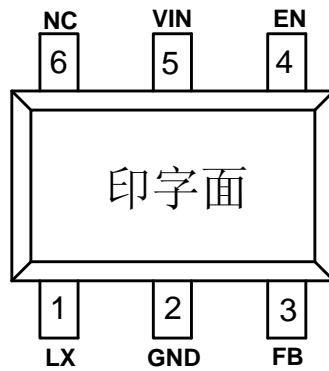

SOT23-6

Pin information

Pin Number	Name	Function
1	LX	Power Switch Output
2	GND	Ground
3	FB	Feedback
4	EN	Chip Enable(Active High)
5	VIN	Power Supply
6	NC	NC

Block Diagram

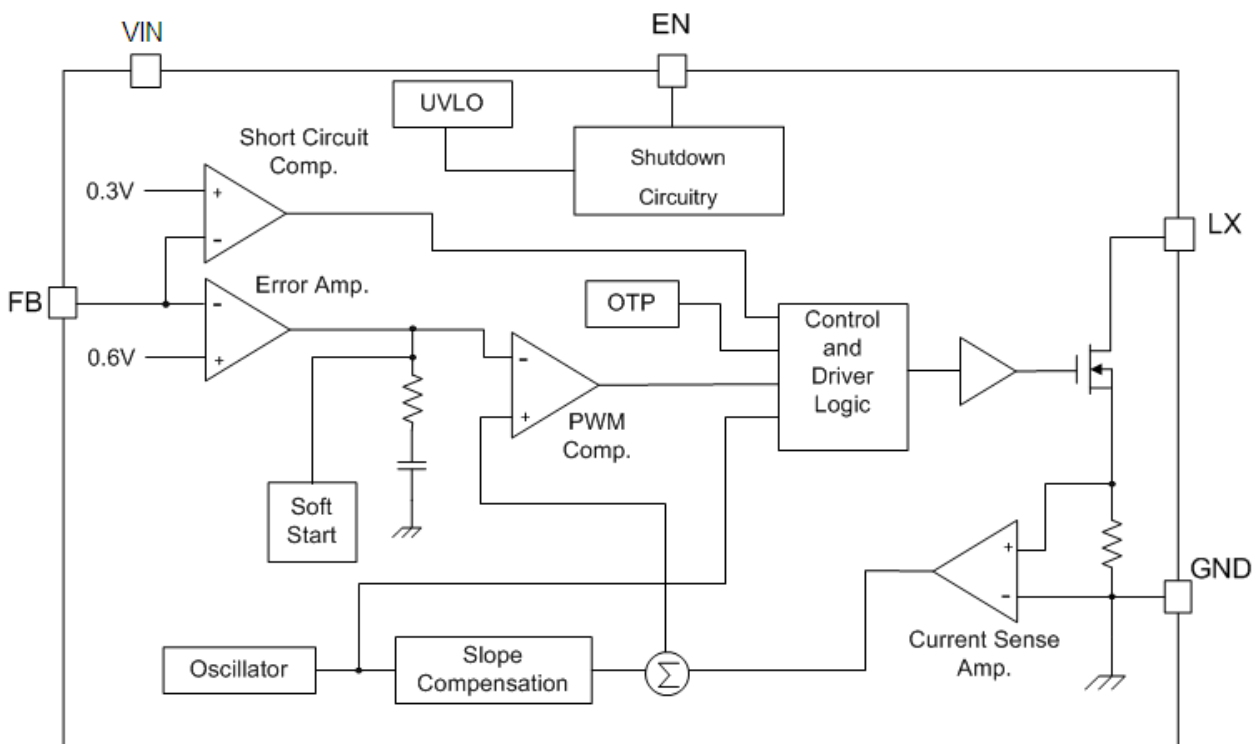

Absolute Maximum Ratings

Parameter	Symbol	Rating	Unit
Power supply voltage, V_{IN}	V_{IN}	-0.3~6.0	V
voltage at EN、FB Pin	V_{EN}, V_{FB}	-0.3~ V_{IN}	V
voltage at SW Pin	V_{LX}	-0.3~12	V
LX Pin Current	I_{LX}	1850 ($V_{IN}=3.0V, V_{OUT}=5.0V$)	mA
Internal Power Dissipation (SOT23-6)	P_D	0.6	W
Thermal resistance (Junction to air) (SOT23-6)	θ_{JA}	200	°C/W
Operating Ambient Temperature	T_{opr}	-40~+85	°C
Storage Temperature	T_{stg}	-55~+150	°C
Maximum junction temperature	T_J	-40~+150	°C
Soldering temperature and time	T_{solder}	260°C, 10S	°C

Electrical Characteristics

($V_{IN} = V_{EN}=3.3V$, $V_{OUT}=5V$, $C1 = C2 = 22\mu F$, $L=4.7\mu H$, $T_A = 25^\circ C$, unless otherwise noted.)

Parameter	Symbol	Test condition	Min	Typ.	Max	Unit
System Supply Input						
Input voltage range	V_{IN}		2.5	-	5.5	V
Under Voltage Lockout	V_{UVLO}		-	2.15	-	V
UVLO Hysteresis			-	0.08	-	V
Average Supply Current	I_{SS1}	$V_{FB}=0.55V$, Switching	-	0.8	1.5	mA
Quiescent Current	I_{SS2}	$V_{FB}=0.66V$, No Switching	-	280	360	μA
Shutdown Supply Current	I_{SS3}	$V_{EN}=GND$	-	0.1	5	μA
Oscillator						
Operation Frequency	F_{OSC}	$V_{FB}=1.0V$	0.5	0.65	0.8	MHz
Maximum Duty Cycle	D_{MAX}		-	90	-	%
Minimum Duty Cycle	D_{MIN}		-	22	-	%
Reference Voltage						
Reference Voltage	V_{FB}		0.588	0.6	0.612	V
Line Regulation		$V_{IN}=2.6V$ to $4.3V$	-	0.03	0.1	%/V
Enable Control						
Enable Voltage	V_{EN}		1.5	-	-	V
Shutdown Voltage	V_{EN}		-	-	0.6	V
MOSFET						
On Resistance of Driver	$R_{DS(ON)}$	$I_{LX}=2A$	-	0.18	-	Ω
Protection						
OCP Current	I_{OCP}		-	1.85	-	A
Over Temperature Protection	OTP		-	165	-	°C
OTP Hysteresis	OTH		-	25	-	°C

Typical Performance Characteristics (ME2159AM6G)

1、Output Voltage VS. Output Current (Vout =5.0V)

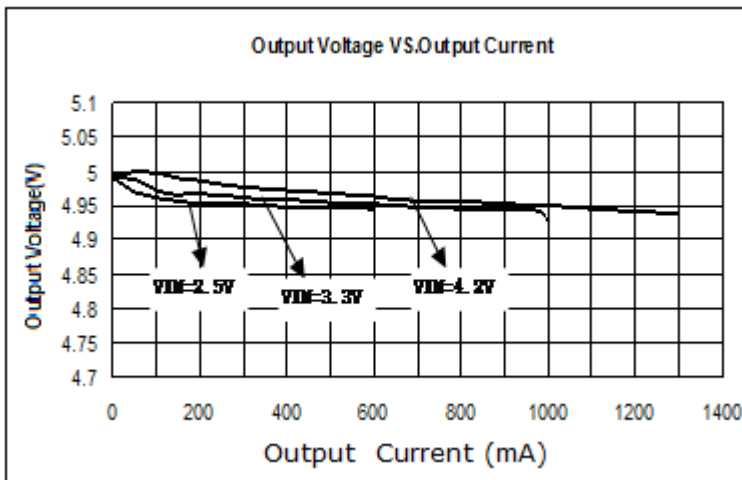

2、Efficiency VS. Output Current (Vout=5.0V)

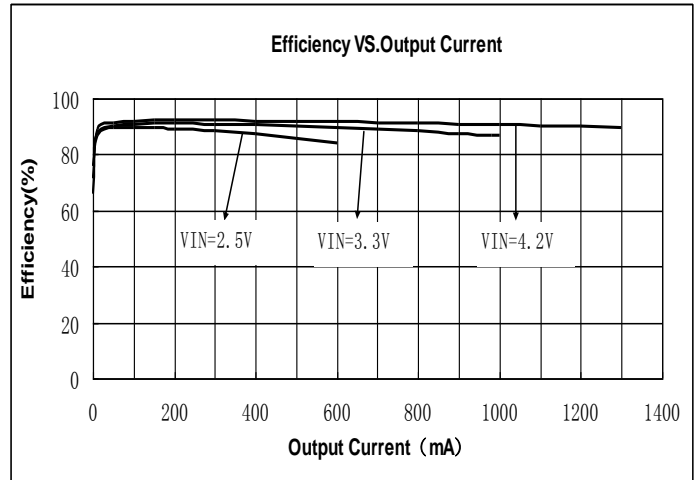

3、V_{OUT} VS. Input Voltage (I_{OUT}=10mA)

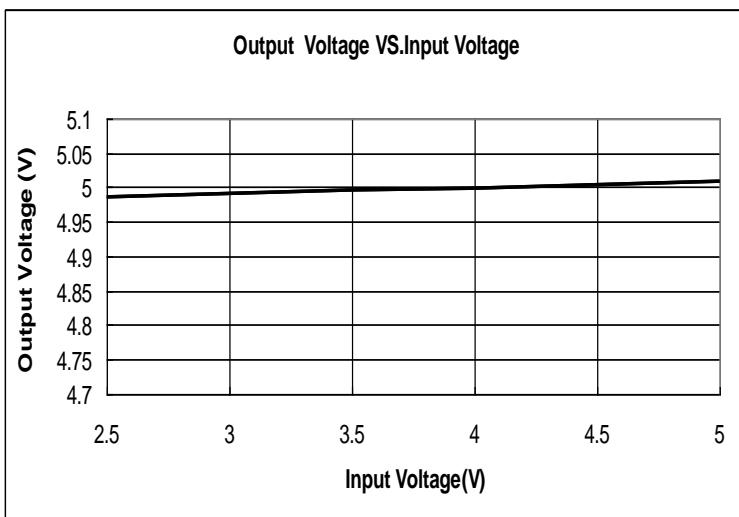

4、I_{SS1} VS. Input Voltage

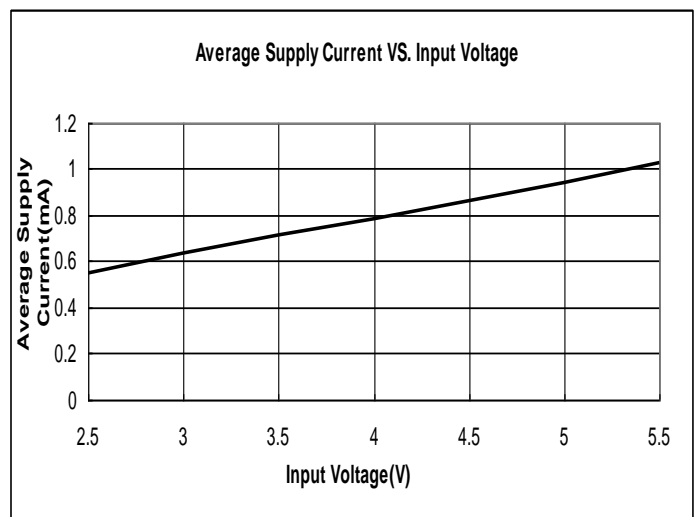

5、I_{SS2} VS. Input Voltage

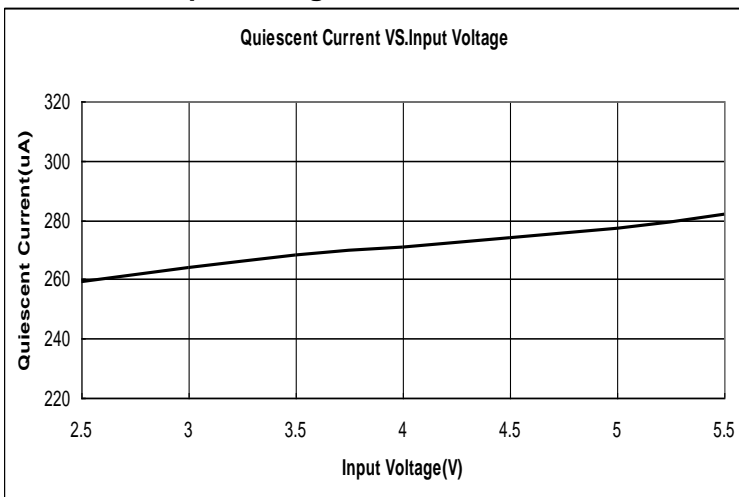

6、Oscillator Frequency VS. Input Voltage

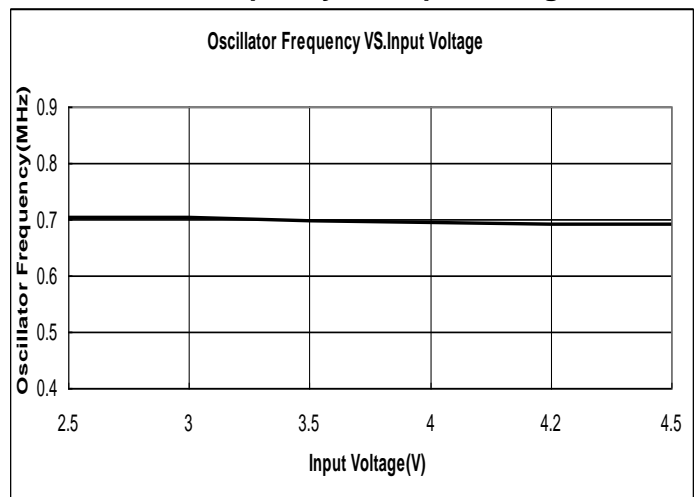

Function Description

Operation

The ME2159A is a current mode boost converter. The constant switching frequency is 1MHz and operates with pulse width modulation (PWM). Build-in 16V / 2A MOSFET provides a high output voltage. The control loop architecture is peak current mode control; therefore slope compensation circuit is added to the current signal to allow stable operation for duty cycles larger than 50%.

Soft Start Function

Soft start circuitry is integrated into ME2159A to avoid inrush current during power on. After the IC is enabled, the output of error amplifier is clamped by the internal soft-start function, which causes PWM pulse width increasing slowly and thus reducing input surge current.

Over Temperature Protection (OTP)

The ME2159A will turn off the power MOSFET automatically when the internal junction temperature is over 150°C. The power MOSFET wake up when the junction temperature drops 30° C under the OTP threshold temperature.

Output Disconnect

When power on and the EN pin will be pulled high. The ME2159A start up and operates. The external PMOS is turned on and current through it for output loading. While output loading is increase, output voltage is drop. When the FB pin voltage is under 0.3V, the EN pin sinks 20μA current, the external PMOS will be turn off. The output short condition will be disconnected.

Application Information

Inductor Selection

Inductance value is decided based on different condition. 3.3uH to 4.7μH inductor value is recommended for general application circuit. There are three important inductor specifications, DC resistance, saturation current and core loss. Low DC resistance has better power efficiency. Also, it avoids inductor saturation which will cause circuit system unstable and lower core loss at 1MHz.

Capacitor Selection

The output capacitor is required to maintain the DC voltage. Low ESR capacitors are preferred to reduce the output voltage ripple. Ceramic capacitor of X5R and X7R are recommended, which have low equivalent series resistance (ESR) and wider operation temperature range.

Diode Selection

Schottky diodes with fast recovery times and low forward voltages are recommended. Ensure the diode average

and peak current rating exceed the average output current and peak inductor current. In addition, the diode's reverse breakdown voltage must exceed the output voltage.

Output Voltage Programming

The output voltage is set by a resistive voltage divider from the output voltage to FB. The output voltage is:

$$V_{\text{OUT}} = 0.6 \times \left(1 + \frac{R_1}{R_2} \right)$$

PCB Layout Check List

When laying out the printed circuit board, the following checklist should be used to ensure proper operation of the ME2159A.

1. The power traces, consisting of the GND trace, the SW trace and the V_{IN} trace should be kept short, direct and wide.
2. LX、L and D switching node, wide and short trace to reduce EMI.
3. Place CIN near VCC pin as closely as possible to maintain input voltage steady and filter out the pulsing input current.
4. The resistive divider R1 and R2 must be connected to FB pin directly as closely as possible. the internal power MOSFETs.
5. FB is a sensitive node. Please keep it away from switching node, LX.
6. The GND of the IC, CIN and COUT should be connected close together directly to a ground plane.

Package Information

- Package type:SOT23-6

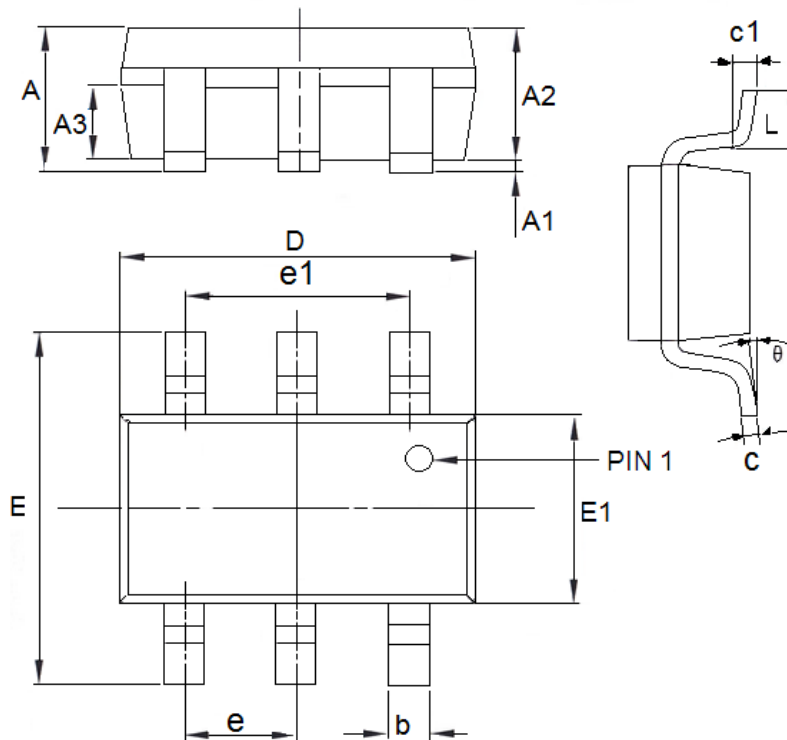

DIM	Millimeters		Inches	
	Min	Max	Min	Max
A	1.05	1.45	0.0413	0.0571
A1	0	0.15	0.0000	0.0059
A2	0.9	1.3	0.0354	0.0512
A3	0.55	0.75	0.0217	0.0295
b	0.25	0.5	0.0098	0.0197
c	0.1	0.25	0.0039	0.0098
D	2.7	3.12	0.1063	0.1228
e1	1.9(TYP)		0.0748(TYP)	
E	2.6	3.1	0.1024	0.1220
E1	1.4	1.8	0.0551	0.0709
e	0.95(TYP)		0.0374(TYP)	
L	0.25	0.6	0.0098	0.0236
θ	0	8°	0.0000	8°
c1	0.2(TYP)		0.0079(TYP)	

- The contents of this document will be updated with the product's improvement without prior notice. Please consult our sales staff before using this document to ensure that you are using the latest version.
- The application circuit examples described in this document are only used to indicate the representative use of the product and do not guarantee the design of mass production.
- Please use this product within the limits stated in this document. We will not be responsible for any damage caused by improper use.
- The products described in this document are not allowed to be used in equipment or devices that affect the human body without the written permission of our company, including but not limited to: health equipment, medical equipment, disaster prevention equipment, fuel control equipment, automobile equipment, aviation equipment and vehicle equipment.
- Although our company has always been committed to improving product quality and reliability, semiconductor products have a certain probability of malfunction or wrong work. To prevent personal injury or property damage caused by such accidents, please pay full attention to safety design, for example: Alternate design, fire protection design, and prevention of wrong action design.
- When exporting this product or this document overseas, you should abide by applicable import and export control laws.
- Copying or reprinting part or all of this document in any form without the permission of our company is strictly prohibited.