

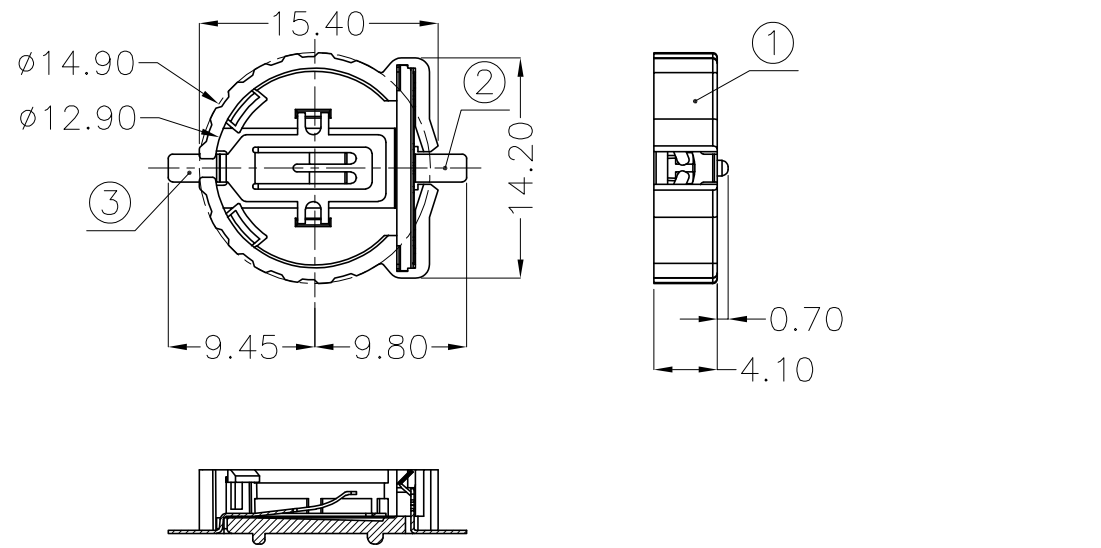

REV.	ECN NO.	REVISED	DATE

1.MATERIAL:
a.HOUSING:PPA
b.CONTACT:PHOSPHOR BRONZE
(SURFACE PLATING: Au1u")
SEE ORDERING INFORMATION

2.ELECTRIC:
a.CONTACT RESISTANCE: 30 MILLIOHMS MAX
b.INSULATION RESISTANCE: 100 MEGA OHMS MIN
c.DIELECTNIC VOLTAGE: 500V AC ONE MINUTE
d.OPERATING TEMPERATURE: -25°C~ +85°C



ORDERING INFORMATION

BS-12-B2AA002

电池座系列
BS-12系列
SMT 180° TYPE

PLATING:
A-Au1U"
J-Ni100U"~120U"
K-Sn100U"~120U"

MATERIAL:
1A-PBT BLACK
1B-PA66 BLACK
2A-PPA BROWN
2B-PPA BLACK
3A-PPS BROWN
3B-PPS BLACK
4A-LCP WHITE
4B-LCP BLACK

工程部
2024-01-11
LQ. HUANG

PCB Layout Diagram
Top View

UNLESS OTHERWISE SPECIFIED TOLERANCES		MYOUNG 美用 www.meiyangdz.com					
DECIMALS: X :±0.30 X.X :±0.25 X.XX :±0.20 X.XXX :±0.10	ANGLES: X :±1° X.X :±0.5°	DSND	HuangLieQing	DATE	2024-01-11	TITLE:	BS-1220-2 PPA SMT
WEIGHT: 0.63g		CHKD	ZhouRuicai	DATE	2024-01-11	PART NO.:	BS-12-B2AA002
SHEET 1 OF 1		APVD	XueShunYong	DATE	2024-01-11	VIEW:	⊙ ⊞
NO. PART NAME Q'TY MATERIAL PLATING & COLOR		SCALE: 2:1	SIZE: A4	REV.: A/0	OBJECT: MY	DRAW NO.:MY-CP-0031	

3	TERMINAL(-)	1	PHOSPHOR BRONZE, T=0.20mm	Gold Plating and Ni Under-Plating
2	TERMINAL(+)	1	PHOSPHOR BRONZE, T=0.20mm	Gold Plating and Ni Under-Plating
1	HOUSING	1	PPA	BROWN
NO.	PART NAME	Q'TY	MATERIAL	PLATING & COLOR