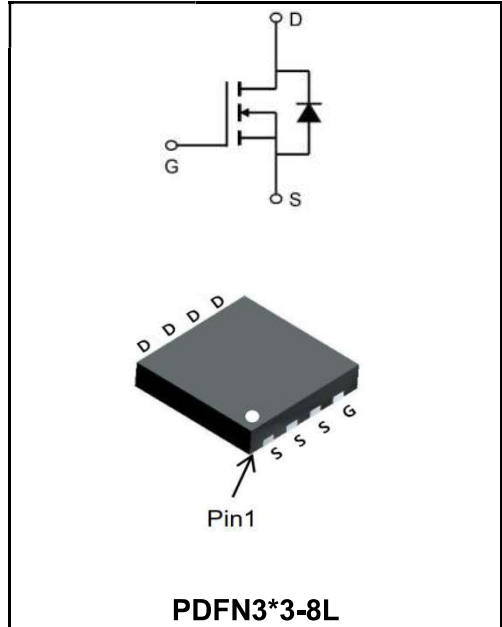


**40V N-CHANNEL ENHANCEMENT MODE MOSFET**

**MAIN CHARACTERISTICS**

<b>I<sub>D</sub></b>	80A
<b>V<sub>DSS</sub></b>	40V
<b>R<sub>DS(on)-typ(@V<sub>GS</sub>=10V)</sub></b>	< 6.5mΩ ( <b>Type:4.8 mΩ</b> )



**Application**

- ◆ Battery protection
- ◆ Load switch
- ◆ Uninterruptible power supply

**Product Specification Classification**

Part Number	Package	Marking	Pack
YFW80N04DF	PDFN3*3-8L	YFW 80N04DF XXXXX	5000PCS/Tape

**Maximum Ratings at T<sub>c</sub>=25°C unless otherwise specified**

Characteristics	Symbols	Value	Units
Drain-Source Voltage	<b>V<sub>DS</sub></b>	40	<b>V</b>
Gate - Source Voltage	<b>V<sub>GS</sub></b>	±20	<b>V</b>
Continuous Drain Current, V <sub>GS</sub> @ 10V <sup>1</sup> @T <sub>C</sub> =25°C	<b>I<sub>D</sub></b>	80	<b>A</b>
Continuous Drain Current, V <sub>GS</sub> @ 10V <sup>1</sup> @T <sub>C</sub> =100°C	<b>I<sub>D</sub></b>	58	<b>A</b>
Pulsed Drain Current <sup>2</sup>	<b>I<sub>DM</sub></b>	150	<b>A</b>
Single Pulse Avalanche Energy <sup>3</sup>	<b>E<sub>AS</sub></b>	110.5	<b>mJ</b>
Avalanche Current	<b>I<sub>AS</sub></b>	47	<b>A</b>
Total Power Dissipation <sup>4</sup> @T <sub>C</sub> =25°C	<b>P<sub>D</sub></b>	52.1	<b>W</b>
Storage Temperature Range	<b>T<sub>STG</sub></b>	-55 to +150	<b>°C</b>
Operating Junction Temperature Range	<b>T<sub>J</sub></b>	-55 to +150	<b>°C</b>
Thermal Resistance Junction-Ambient <sup>1</sup>	<b>R<sub>θJA</sub></b>	62	<b>°C/W</b>
Thermal Resistance Junction-Case <sup>1</sup>	<b>R<sub>θJC</sub></b>	2.4	<b>°C/W</b>

**Maximum Ratings at Tc=25°C unless otherwise specified**

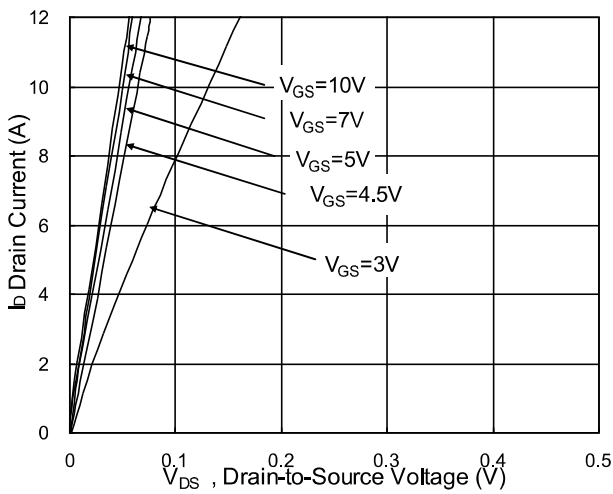
Characteristics	Test Condition	Symbols	Min	Typ	Max	Units
Drain-Source Breakdown Voltage	$V_{GS}=0V, I_D=250\mu A$	$BV_{DSS}$	40	-	-	V
BVDSS Temperature Coefficient	Reference to 25°C, $I_D=1mA$	$\Delta BV_{DSS}/\Delta T_J$	-	0.034	-	V/°C
Static Drain-Source On-Resistance <sup>2</sup>	$V_{GS}=10V, I_D=15A$	$R_{DS(ON)}$	-	4.8	6.5	mΩ
	$V_{GS}=4.5V, I_D=12A$		-	7.2	9	
Gate -Threshold Voltage	$V_{DS}=V_{GS}, I_D=250\mu A$	$V_{GS(th)}$	1.0	-	2.5	V
$V_{GS(th)}$ Temperature Coefficient		$\Delta V_{GS(th)}$	-	-5.84	-	mV/°C
Drain -Source Leakage Current	$V_{DS}=32V, V_{GS}=0V, T_J=25^\circ C$	$I_{DSS}$	-	-	1	μA
	$V_{DS}=32V, V_{GS}=0V, T_J=55^\circ C$		-	-	5	
Gate-Source Leakage Current	$V_{GS}=\pm 20V, V_{DS}=0V$	$I_{GSS}$	-	-	±100	nA
Forward Transconductance	$V_{DS}=5V, I_D=15A$	$g_{FS}$	-	27	-	S
Gate Resistance	$V_{DS}=0V, V_{GS}=0V, f=1MHz$	$R_g$	-	1.4	-	Ω
Total Gate Charge(4.5V)	$V_{DS}=20V$ $V_{GS}=4.5V$ $I_D=12A$	$Q_g$	-	28	-	nC
Gate-Source Charge		$Q_{gs}$	-	7.85	-	
Gate-Drain Charge		$Q_{gd}$	-	12.5	-	
Turn-on delay time	$V_{DD}=15V$ $V_{GS}=10V$ $R_G=3.3\Omega$ $I_D=1A$	$t_{d(on)}$	-	20.2	-	ns
Rise Time		$T_r$	-	11.8	-	
Turn-Off Delay Time		$t_{d(OFF)}$	-	84.8	-	
Fall Time		$t_f$	-	8.6	-	
Input Capacitance	$V_{DS}=15V$ $V_{GS}=0V$ $f=1.0MHz$	$C_{iss}$	-	3354	-	pF
Output Capacitance		$C_{oss}$	-	275	-	
Reverse Transfer Capacitance		$C_{rss}$	-	204	-	
Continuous Source Current <sup>1,5</sup>	$V_G=V_D=0V, \text{Force Current}$	$I_S$	-	-	75	A
Pulsed Source Current <sup>2,5</sup>		$I_{SM}$	-	-	150	A
Diode Forward Voltage <sup>2</sup>	$V_{GS}=0V, I_S=1A, T_J=25^\circ C$	$V_{SD}$	-	-	1	V

Note :

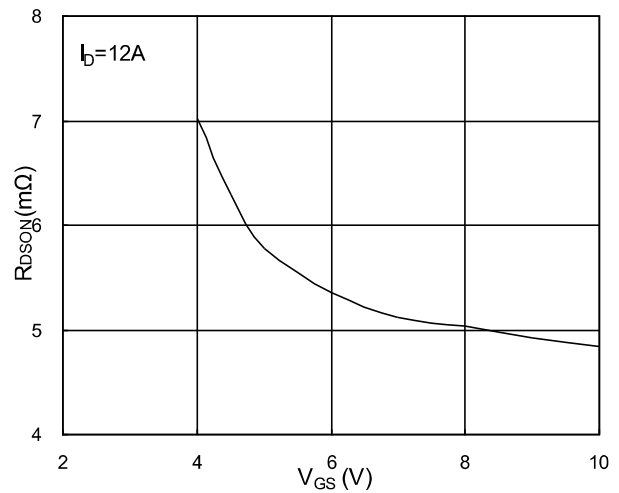
- 1、.The data tested by surface mounted on a 1 inch<sup>2</sup> FR-4 board with 2OZ copper.
- 2、 The data tested by pulsed , pulse width  $\leq 300\mu s$  , duty cycle  $\leq 2\%$
- 3、 The EAS data shows Max. rating . The test condition is  $V_{DD}=25V, V_{GS}=10V, L=0.1mH, I_{AS}=47A$
- 4、 The power dissipation is limited by 150°C junction temperature
- 5、 The data is theoretically the same as  $I_D$  and  $I_{DM}$  , in real applications , should be limited by total power dissipation.

**Ratings and Characteristic Curves**

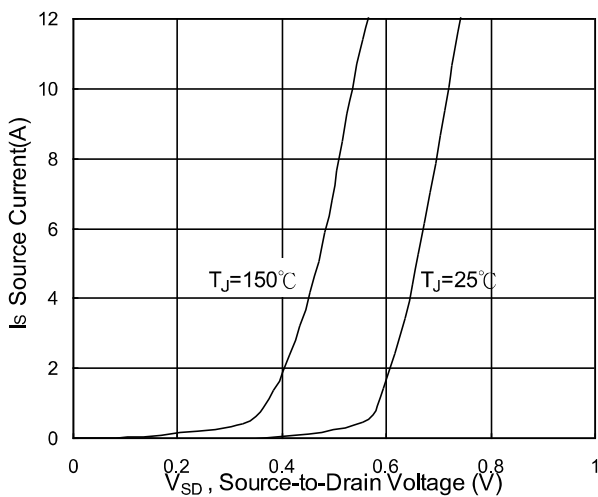
**Typical Characteristics**



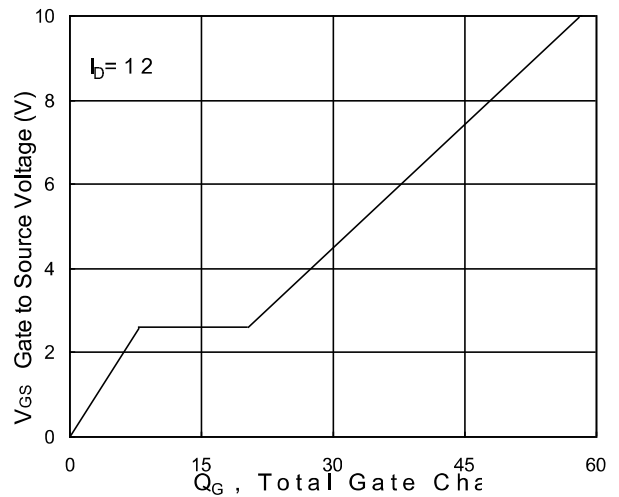
**Fig.1 Typical Output Characteristics**



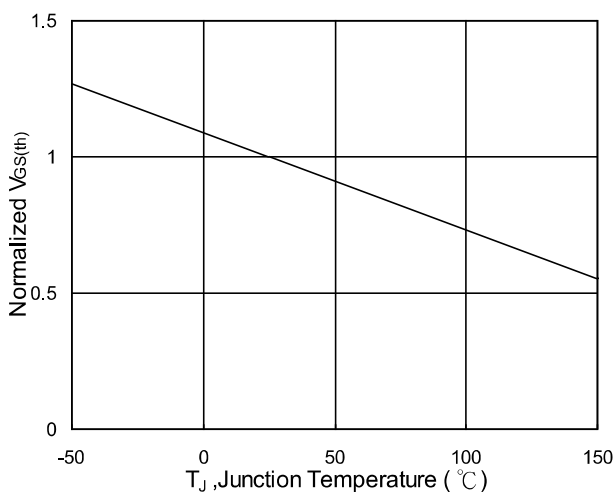
**Fig.2 On-Resistance vs. G-S Voltage**



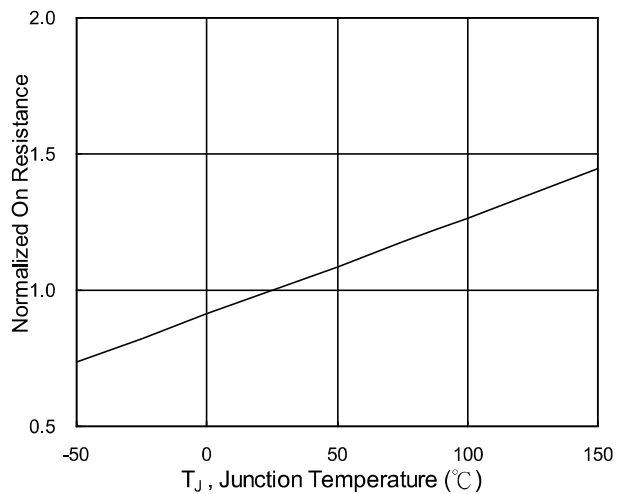
**Fig.3 Forward Characteristics Of Reverse**



**Fig.4 Gate-Charge Characteristics**

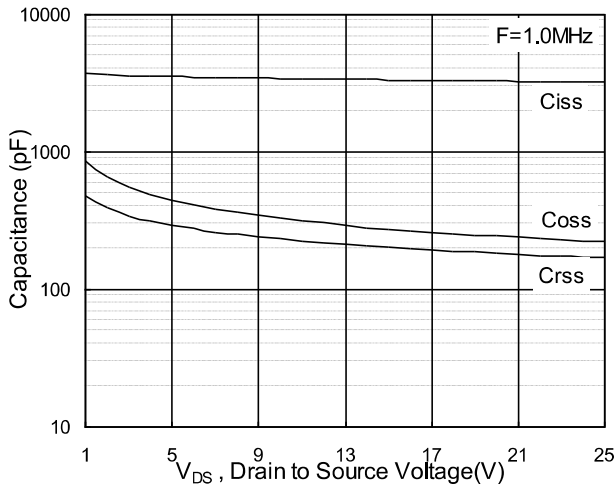


**Fig.5 Normalized  $V_{GS(th)}$  vs.  $T_J$**

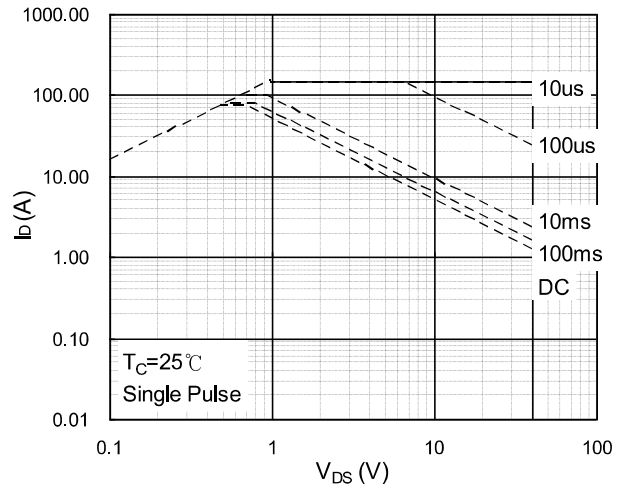


**Fig.6 Normalized  $R_{DS(on)}$  vs.  $T_J$**

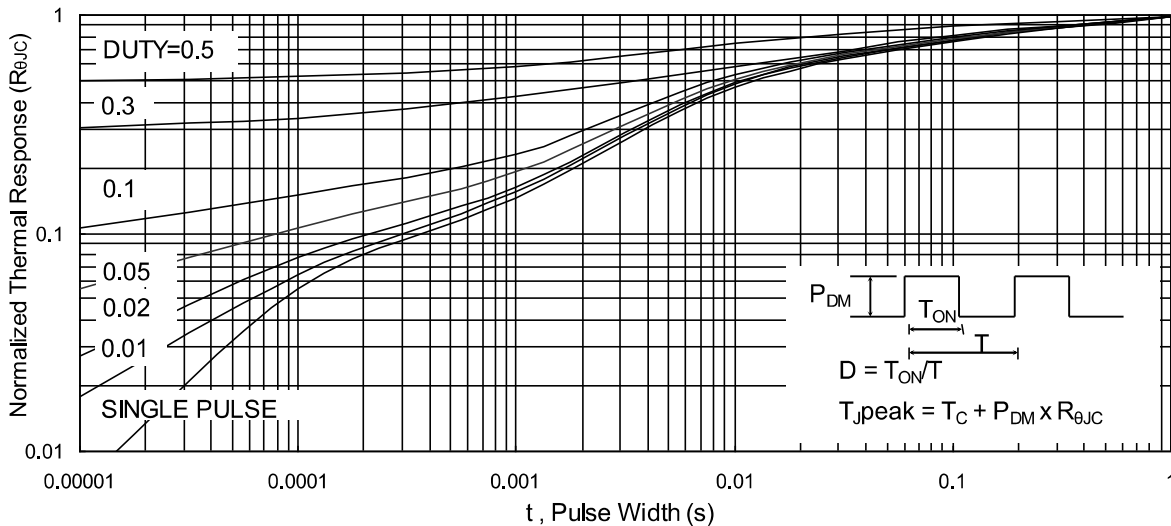
**Ratings and Characteristic Curves**



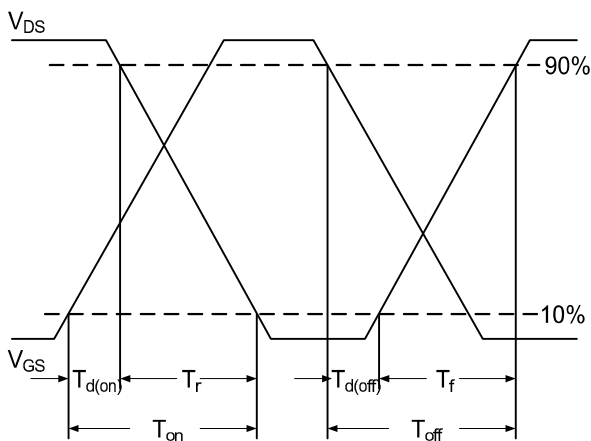
**Fig.7 Capacitance**



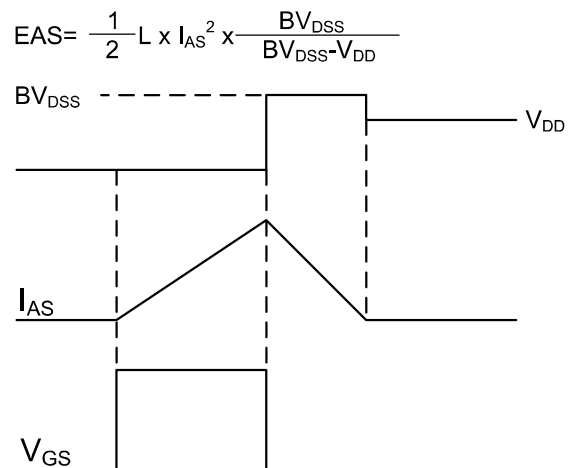
**Fig.8 Safe Operating Area**



**Fig.9 Normalized Maximum Transient Thermal Impedance**

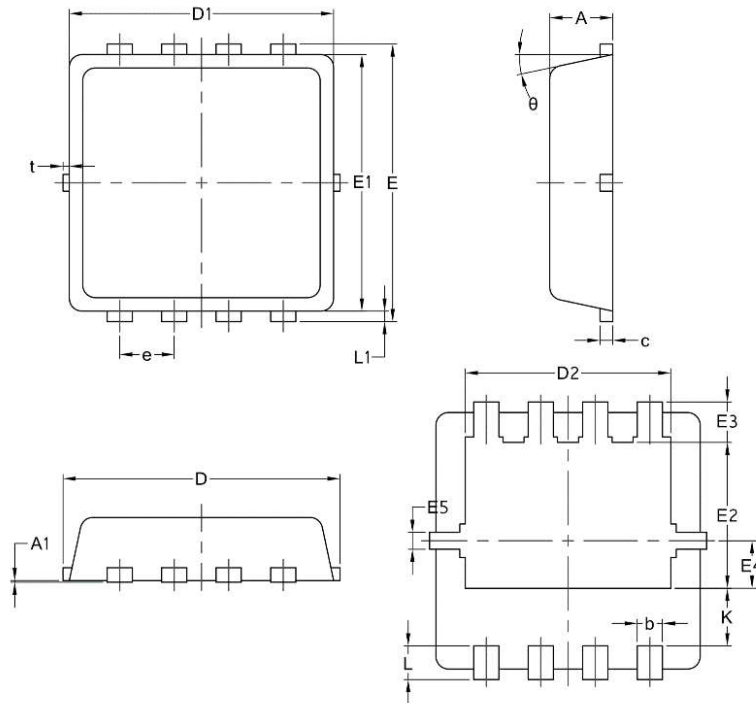


**Fig.10 Switching Time Waveform**



**Fig.11 Unclamped Inductive Switching Wave**

**PDFN3\*3-8L**



Symbol	Common		
	mm		
	Mim	Nom	Max
A	0.70	0.75	0.85
A1	/	/	0.05
b	0.20	0.30	0.40
c	0.10	0.152	0.25
D	3.15	3.30	3.45
D1	3.00	3.15	3.25
D2	2.29	2.45	2.65
E	3.15	3.30	3.45
E1	2.90	3.05	3.20
E2	1.54	1.74	1.94
E3	0.28	0.48	0.65
E4	0.37	0.57	0.77
E5	0.10	0.20	0.30
e	0.60	0.65	0.70
K	0.59	0.69	0.89
L	0.30	0.40	0.50
L1	0.06	0.125	0.20
t	0	0.075	0.13
Φ	10	12	14