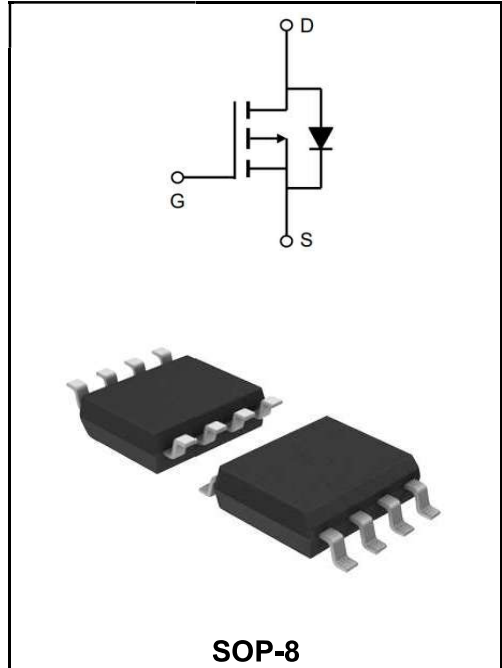


**-40V P-CHANNEL ENHANCEMENT MODE MOSFET**

**MAIN CHARACTERISTICS**

<b>I<sub>D</sub></b>	-8A
<b>V<sub>DSS</sub></b>	-40V
<b>R<sub>DS(on)-typ(@V<sub>GS</sub>=-10V)</sub></b>	< 32mΩ



**APPLICATION**

- ◆ Battery protection
- ◆ Load switch
- ◆ Uninterruptible power supply

**Product Specification Classification**

Part Number	Package	Marking	Pack
YFW8P04S	SOP-8	YFW 8P04S XXXXX	3000PCS/Tape

**Maximum Ratings at Tc=25°C unless otherwise specified**

Characteristics	Symbols	Value	Units
Drain-Source Voltage	<b>V<sub>DS</sub></b>	-40	<b>V</b>
Gate - Source Voltage	<b>V<sub>GS</sub></b>	±20	<b>V</b>
Continuous Drain Current, V <sub>GS</sub> @ -10V <sup>1</sup> @T <sub>A</sub> =25°C	<b>I<sub>D</sub></b>	-8	<b>A</b>
Continuous Drain Current, V <sub>GS</sub> @ -10V <sup>1</sup> @T <sub>A</sub> =70°C	<b>I<sub>D</sub></b>	-6.9	<b>A</b>
Pulsed Drain Current <sup>2</sup>	<b>I<sub>DM</sub></b>	-32	<b>A</b>
Single Pulse Avalanche Energy <sup>3</sup>	<b>E<sub>AS</sub></b>	41	<b>mJ</b>
Avalanche Current	<b>I<sub>AS</sub></b>	-28.6	<b>A</b>
Total Power Dissipation <sup>4</sup> @T <sub>A</sub> =25°C	<b>P<sub>D</sub></b>	2.5	<b>W</b>
Storage Temperature Range	<b>T<sub>STG</sub></b>	-55 to +150	<b>°C</b>
Operating Junction Temperature Range	<b>T<sub>J</sub></b>	-55 to +150	<b>°C</b>
Thermal Resistance Junction-Ambient <sup>1</sup>	<b>R<sub>θJA</sub></b>	50	<b>°C/W</b>

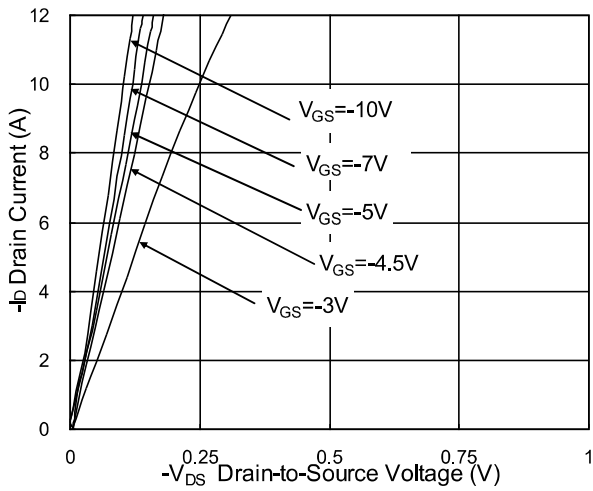
**Maximum Ratings at Tc=25°C unless otherwise specified**

Characteristics	Test Condition	Symbols	Min	Typ	Max	Units
Drain-Source Breakdown Voltage	$V_{GS}=0V, I_D=-250\mu A$	$BV_{DSS}$	-40	-	-	V
BVDSS Temperature Coefficient	Reference to 25°C, $I_D=-1mA$	$\Delta BV_{DSS}/\Delta T_J$	-	-0.02	-	V/°C
Static Drain-Source On-Resistance <sup>2</sup>	$V_{GS}=-10V, I_D=-5A$	$R_{DS(ON)}$	-	-	32	mΩ
	$V_{GS}=-4.5V, I_D=-4A$		-	-	46	
Gate -Threshold Voltage	$V_{DS}=V_{GS}, I_D=-250\mu A$	$V_{GS(th)}$	-1.2	-	-2.5	V
$V_{GS(th)}$ Temperature Coefficient		$\Delta V_{GS(th)}$	-	3.72	-	mV/°C
Drain-Source Leakage Current	$V_{DS}=-32V, V_{GS}=0V, T_J=25^\circ C$	$I_{DSS}$	-	-	-1	μA
	$V_{DS}=-32V, V_{GS}=0V, T_J=55^\circ C$		-	-	-5	
Gate -Source Leakage Current	$V_{GS}=\pm 20V, V_{DS}=0V$	$I_{GSS}$	-	-	±100	nA
Forward Transconductance	$V_{DS}=-5V, I_D=-8A$	$g_{fs}$	-	10.7	-	S
Total Gate Charge(-4.5V)	$V_{DS}=-15V$ $V_{GS}=-4.5V$ $I_D=-1A$	$Q_g$	-	11.5	-	nC
Gate-Source Charge		$Q_{gs}$	-	3.5	-	
Gate-Drain Charge		$Q_{gd}$	-	3.3	-	
Turn-on delay time	$V_{DD}=-15V$ $V_{GS}=-10V$ $I_D=-1A$ $R_G=3.3\Omega$	$t_{d(on)}$	-	22	-	ns
Rise Time		$T_r$	-	15.7	-	
Turn-Off Delay Time		$t_{d(OFF)}$	-	59	-	
Fall Time		$t_f$	-	5.5	-	
Input Capacitance	$V_{DS}=-15V$ $V_{GS}=0V$ $f=1MHz$	$C_{iss}$	-	1415	-	pF
Output Capacitance		$C_{oss}$	-	134	-	
Reverse Transfer Capacitance		$C_{rss}$	-	102	-	
Continuous Source Current <sup>1,5</sup>	$V_G=V_D=0V, \text{Force Current}$	$I_S$	-	-	-8	A
Diode Forward Voltage <sup>2</sup>	$V_{GS}=0V, I_S=-1A, T_J=25^\circ C$	$V_{SD}$	-	-	-1.2	V

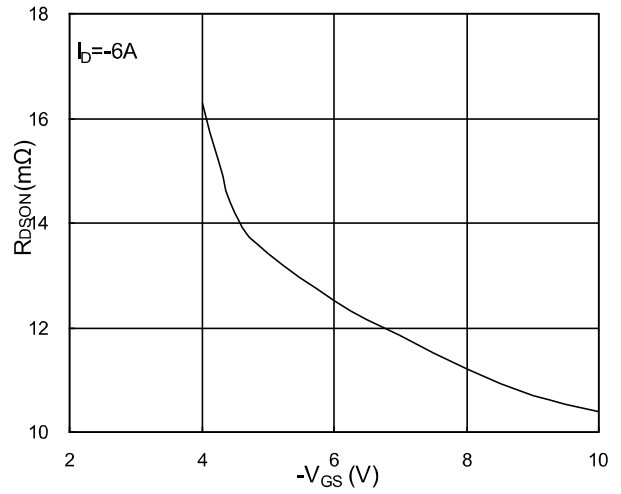
Note :

- 1、 The data tested by surface mounted on a 1 inch 2 FR-4 board with 2OZ copper.
- 2、 The data tested by pulsed , pulse width  $\cong 300\mu s$  , duty cycle  $\cong 2\%$
- 3、 The EAS data shows Max. rating . The test condition is  $V_{DD}=-25V, V_{GS}=-10V, L=0.1mH, I_{AS}=-28.6A$
- 4、 The power dissipation is limited by 150°C junction temperature
- 5、 The data is theoretically the same as  $I_D$  and  $I_{DM}$  , in real applications , should be limited by total power dissipation.

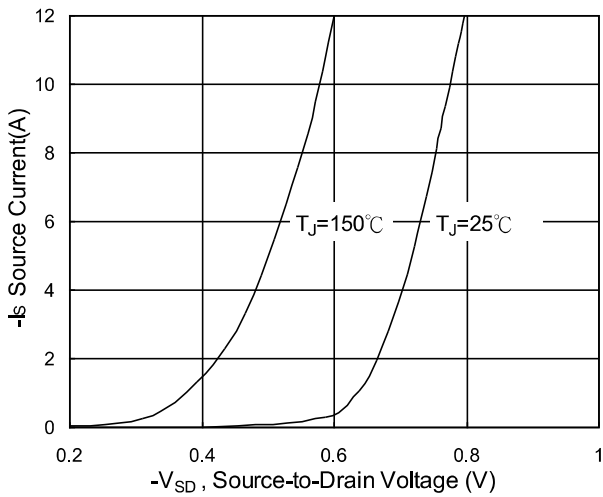
**Ratings and Characteristic Curves**



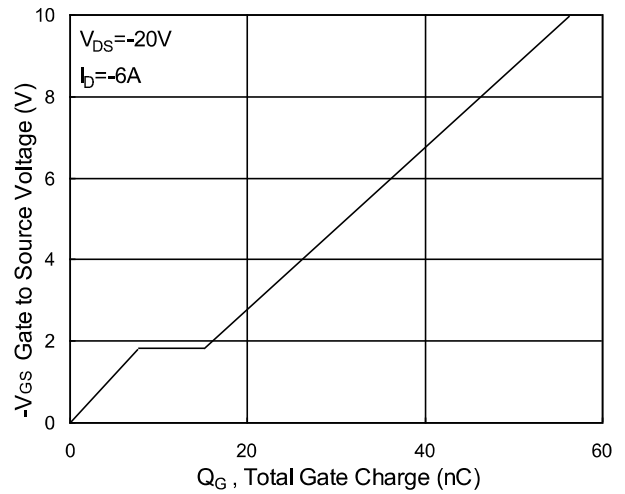
**Fig.1 Typical Output Characteristics**



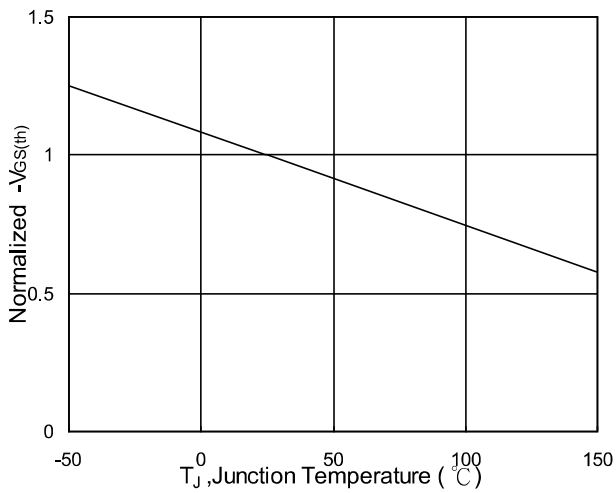
**Fig.2 On-Resistance v.s Gate-Source**



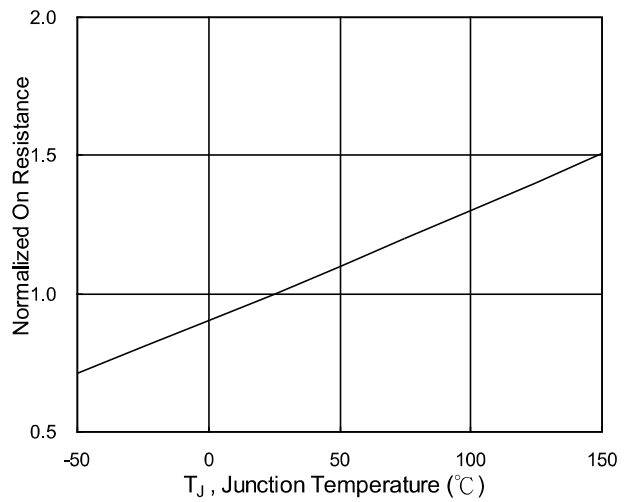
**Fig.3 Forward Characteristics Of Reverse**



**Fig.4 Gate-Charge Characteristics**

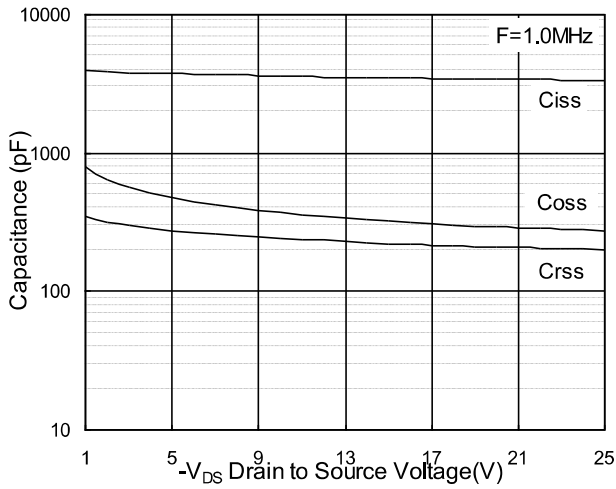


**Fig.5 Normalized  $V_{GS(th)}$  v.s  $T_J$**

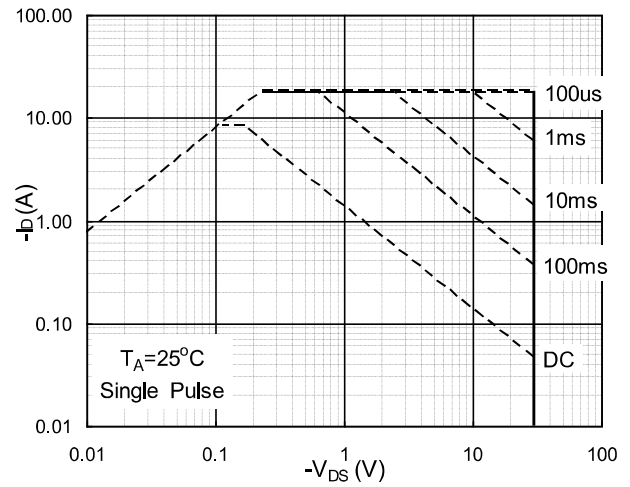


**Fig.6 Normalized  $R_{DS(on)}$  v.s  $T_J$**

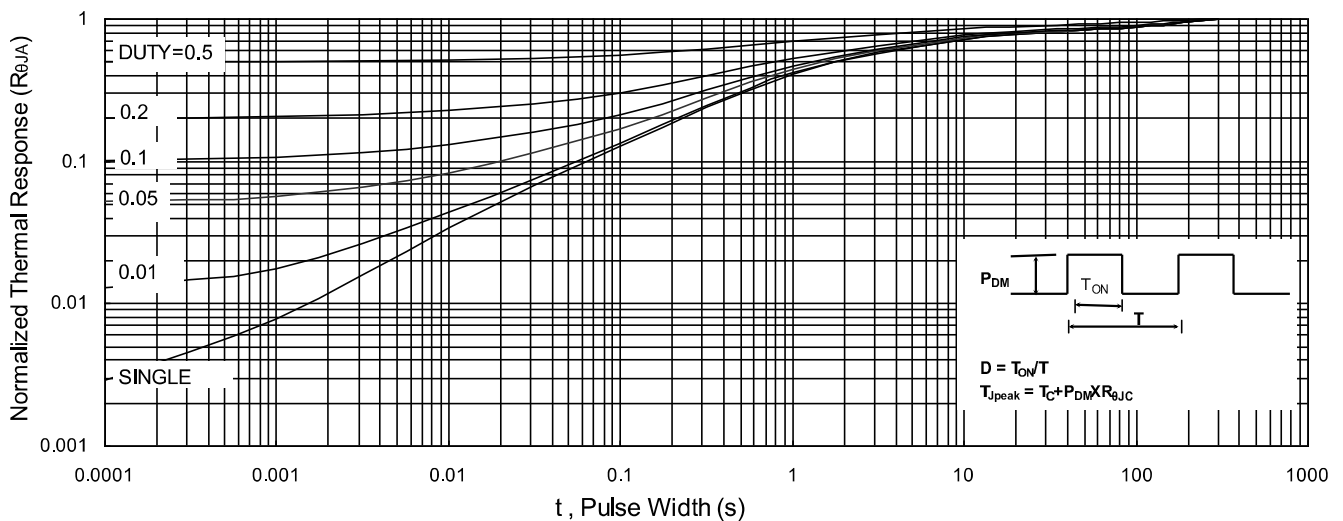
**Ratings and Characteristic Curves**



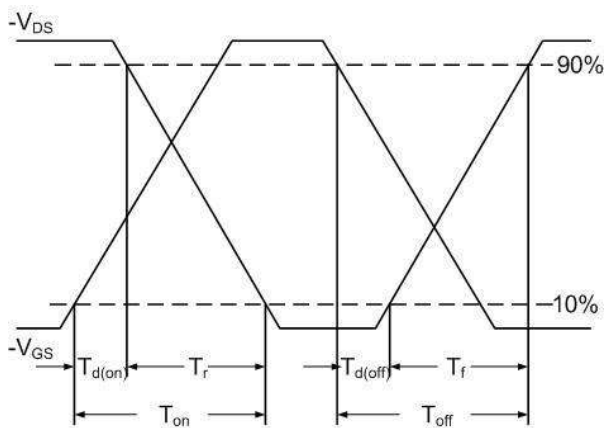
**Fig.7 Capacitance**



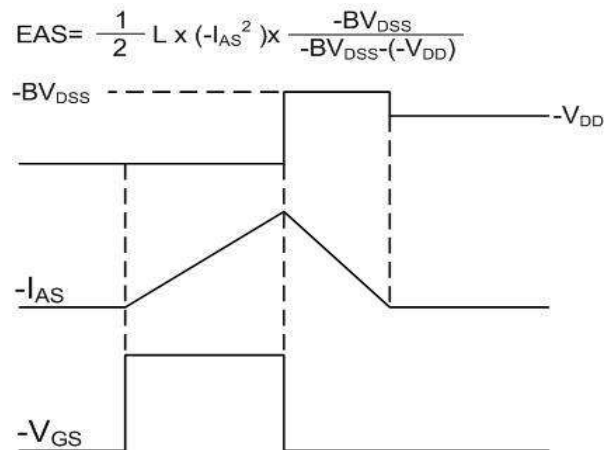
**Fig.8 Safe Operating Area**



**Fig.9 Normalized Maximum Transient Thermal Impedance**

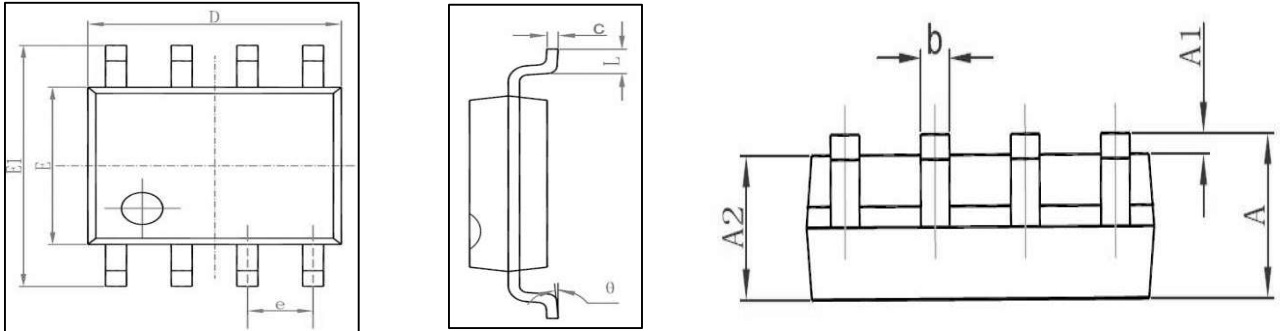


**Fig.10 Switching Time Waveform**

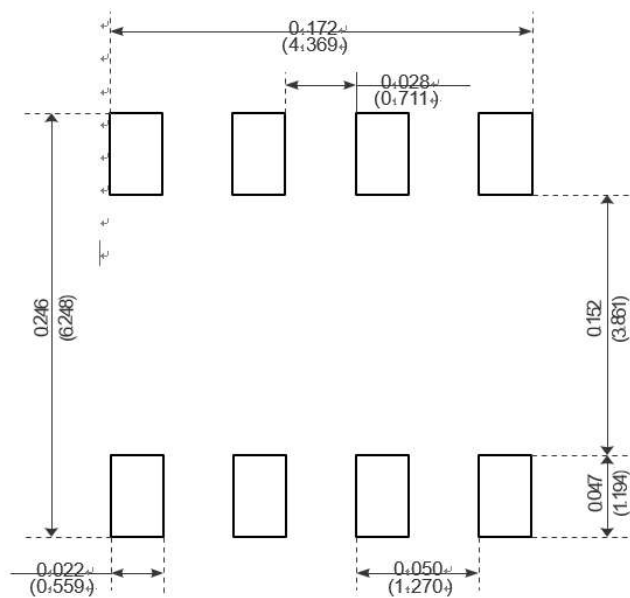


**Fig.11 Unclamped Inductive Waveform**

**SOP-8**



Symbol	Dimensions In Millimeters		Dimensions In Inches	
	Min	Max	Min	Max
A	1.350	1.750	0.053	0.069
A1	0.100	0.250	0.004	0.010
A2	1.350	1.550	0.053	0.061
b	0.330	0.510	0.013	0.020
c	0.170	0.250	0.006	0.010
D	4.700	5.100	0.185	0.200
E	3.800	4.000	0.150	0.157
E1	5.800	6.200	0.228	0.244
e	1.270 (BSC)		0.050 (BSC)	
L	0.400	1.270	0.016	0.050
θ	0°	8°	0°	8°



Recommended Minimum Pads