

100V N-CHANNEL ENHANCEMENT MODE MOSFET

MAIN CHARACTERISTICS

I_D	12.3A
V_{DSS}	100V
R_{DS(on)-typ(@V_{GS}=10V)}	< 110mΩ (Type:93 mΩ)

Application

- ◆Automotive lighting
- ◆Load switch
- ◆PSE

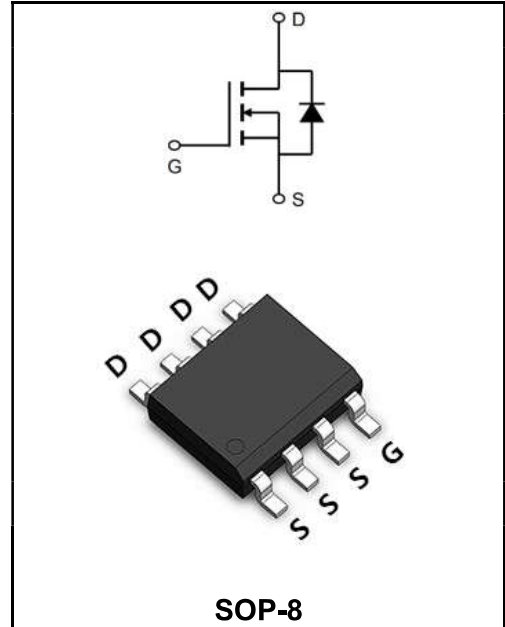

Product Specification Classification

Part Number	Package	Marking	Pack
YFW10N10S	SOP-8	YFW 10N10S XXXXX	3000PCS/Tape

Maximum Ratings at T_c=25°C unless otherwise specified

Characteristics	Symbols	Value	Units
Drain-Source Voltage	V _{DS}	100	V
Gate - Source Voltage	V _{GS}	±20	V
Drain Current, V _{GS} @ 10V @T _C =25°C	I _D	12.3	A
Drain Current, V _{GS} @ 10V @T _C =100°C	I _D	6.5	A
Pulsed Drain Current ¹	I _{DM}	24	A
Total Power Dissipation @T _C =25°C	P _D	30	W
Total Power Dissipation ³ @T _A =25°C	P _D	2.7	W
Storage Temperature Range	T _{STG}	-55 to +150	°C
Operating Junction Temperature Range	T _J	-55 to +150	°C
Maximum Thermal Resistance, Junction ambient	R _{θJA}	85	°C/W
Maximum Thermal Resistance, Junction-case	R _{θJC}	5.1	°C/W

Maximum Ratings at Tc=25°C unless otherwise specified

Characteristics	Test Condition	Symbols	Min	Typ	Max	Units
Drain-Source Breakdown Voltage	$V_{GS}=0V, I_D=250\mu A$	V(BR)DSS	100	107	-	V
Zero Gate Voltage Drain Current	$V_{DS}=100V, V_{GS}=0V$	I_{DSS}	-	-	1.0	μA
Gate to Body Leakage Current	$V_{GS}=\pm 20V, V_{DS}=0V$	I_{GSS}	-	-	±100	nA
Gate Threshold Voltage	$V_{DS}=V_{GS}, I_D=250\mu A$	V_{GS(th)}	1.0	1.5	2.5	V
Static Drain-Source on-Resistance	$V_{GS}=10V, I_D=5A$	R_{DS(on)}	-	93	110	mΩ
	$V_{GS}=4.5V, I_D=3A$		-	100	140	
Input Capacitance	$V_{DS}=25V$ $V_{GS}=0V$ $f=1.0MHz$	C_{iss}	-	645	-	pF
Output Capacitance		C_{oss}	-	38	-	
Reverse Transfer Capacitance		C_{rss}	-	33	-	
Total Gate Charge	$V_{DS}=30V$ $V_{GS}=10V$ $I_D=5A$	Q_g	-	12	-	nC
Gate-Source Charge		Q_{gs}	-	2.2	-	
Gate-Drain("Miller") Charge		Q_{gd}	-	2.5	-	
Turn-on delay time	$V_{DS}=30V$ $I_D=10A$ $R_G=1.8\Omega$ $V_{GS}=10V$	t_{d(on)}	-	7	-	ns
Turn-on Rise Time		T_r	-	5	-	
Turn-Off Delay Time		t_{d(OFF)}	-	16	-	
Turn-Off Fall Time		t_f	-	6	-	
Maximum Continuous Drain to Source Diode Forward Current		I_S	-	-	10	A
Maximum Pulsed Drain to Source Diode Forward Current		I_{SM}	-	-	40	A
Drain to Source Diode Forward Voltage	$V_{GS}=0V, I_S=10A$	V_{SD}	-	-	1.2	V
Body Diode Reverse Recovery Time	$I_F=10A, dI/dt=100A/\mu s$	t_{rr}	-	21	-	ns
Body Diode Reverse Recovery Charge		Q_{rr}	-	21	-	nC

Note :

- 1、 The data tested by surface mounted on a 1 inch 2 FR-4 board with 2OZ copper.
- 2、 The data tested by pulsed , pulse width $\leq 300\mu s$, duty cycle $\leq 2\%$
- 3、 The power dissipation is limited by 150°C junction temperature
- 4、 The data is theoretically the same as I D and I DM , in real applications , should be limited by total power dissipation.

Ratings and Characteristic Curves

Typical Characteristics

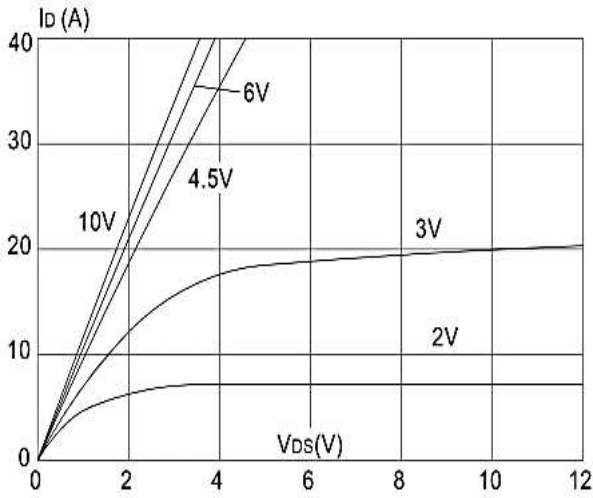

Figure 1: Output Characteristics

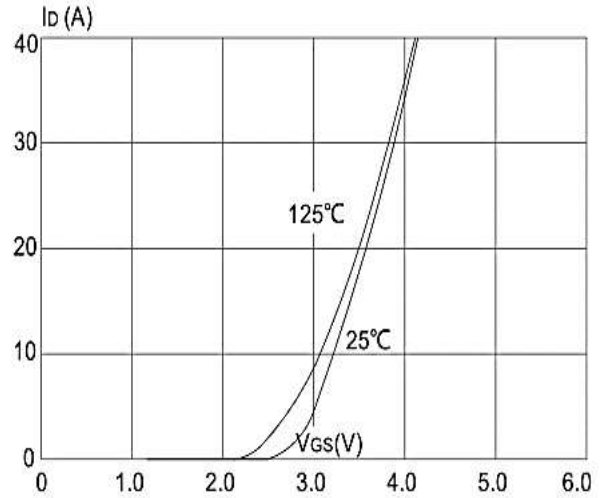

Figure 2: Typical Transfer Characteristics

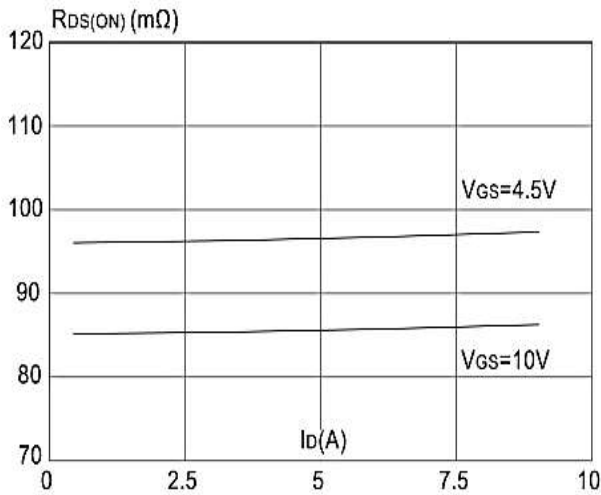

Figure 3: On-resistance vs. Drain Current

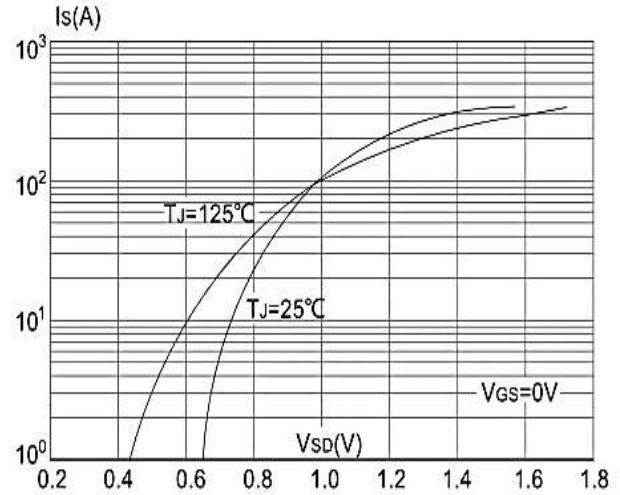

Figure 4: Body Diode Characteristics

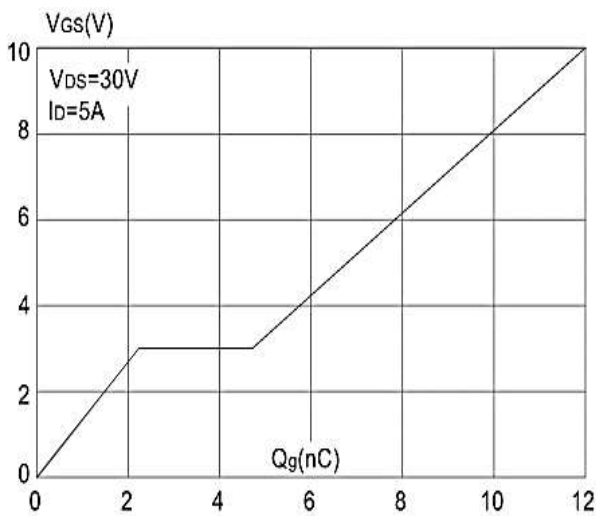

Figure 5: Gate Charge Characteristics

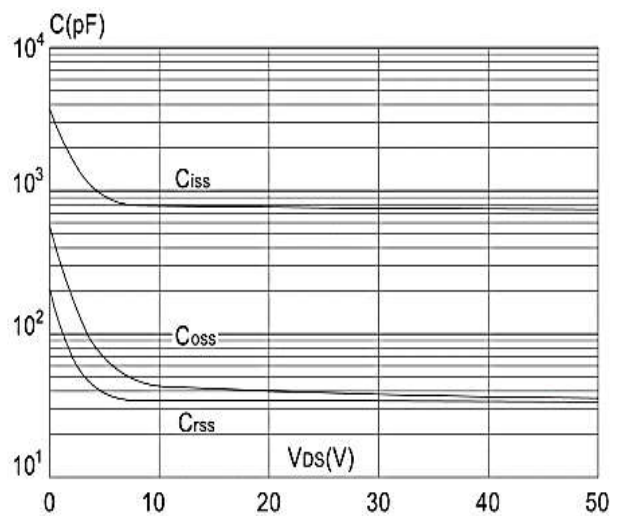

Figure 6: Capacitance Characteristics

Ratings and Characteristic Curves

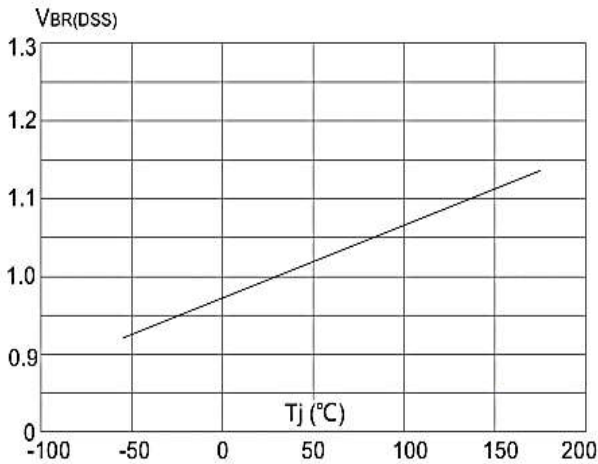

Figure 7: Normalized Breakdown Voltage vs. Junction Temperature

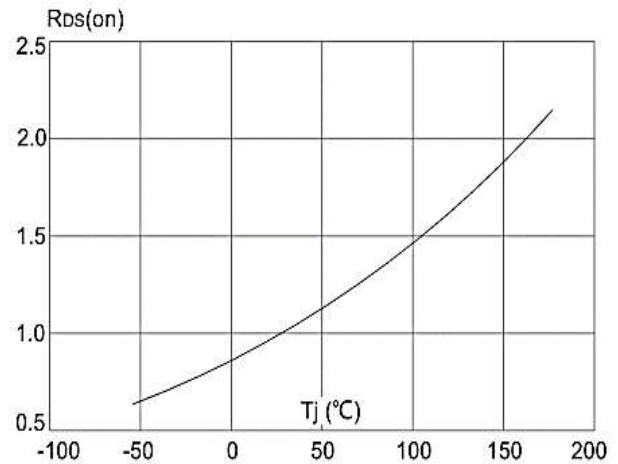

Figure 8: Normalized on Resistance vs. Junction Temperature

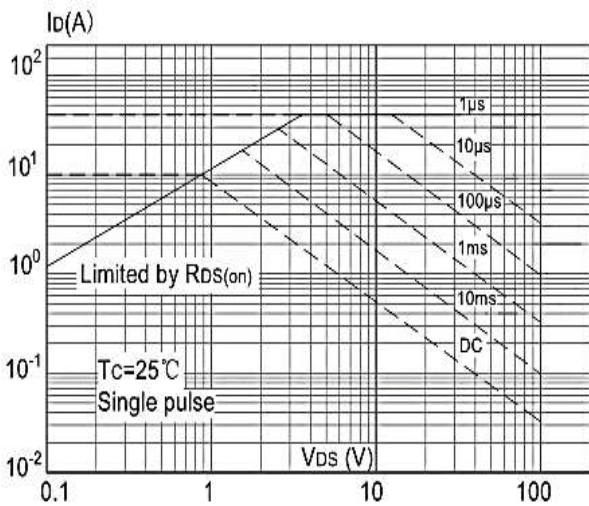

Figure 9: Maximum Safe Operating Area

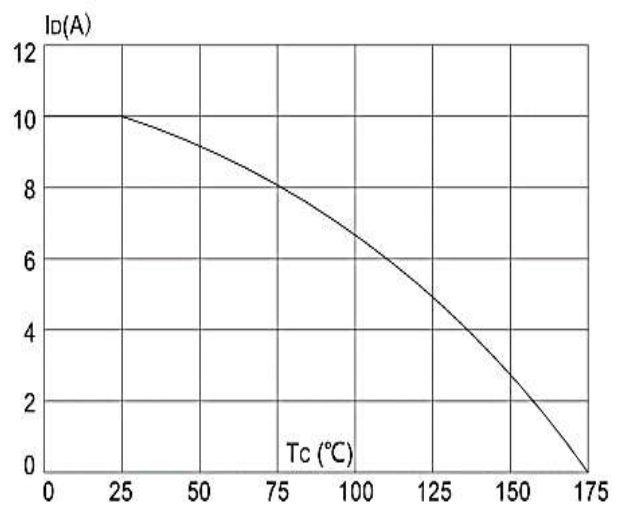

Figure 10: Maximum Continuous Drain Current vs. Case Temperature

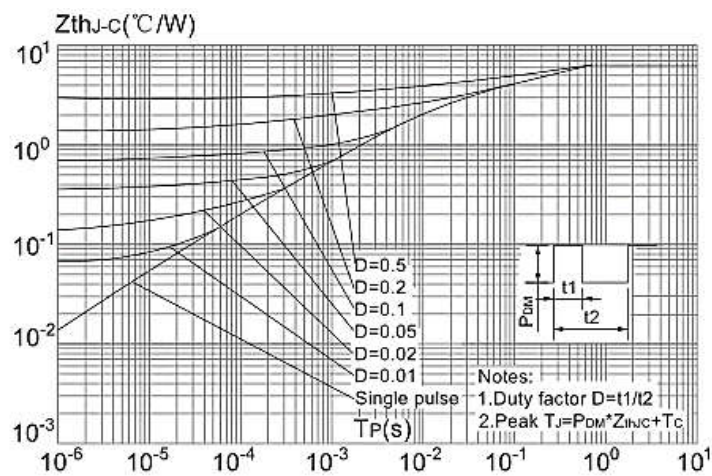
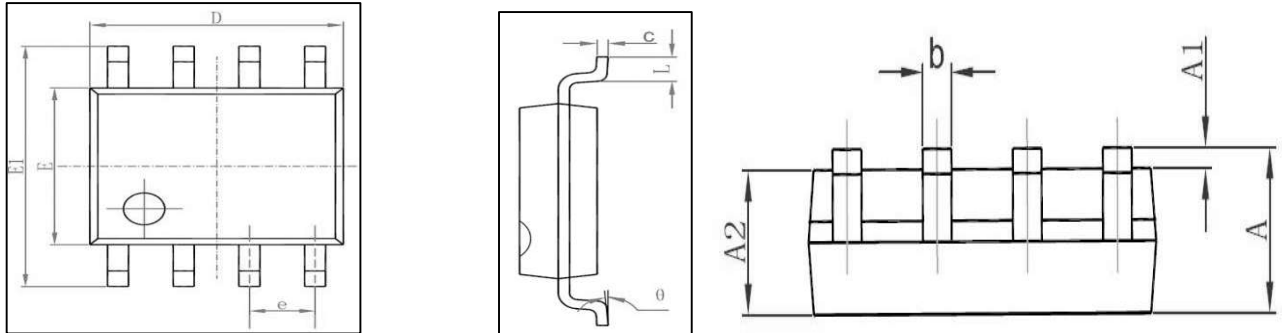
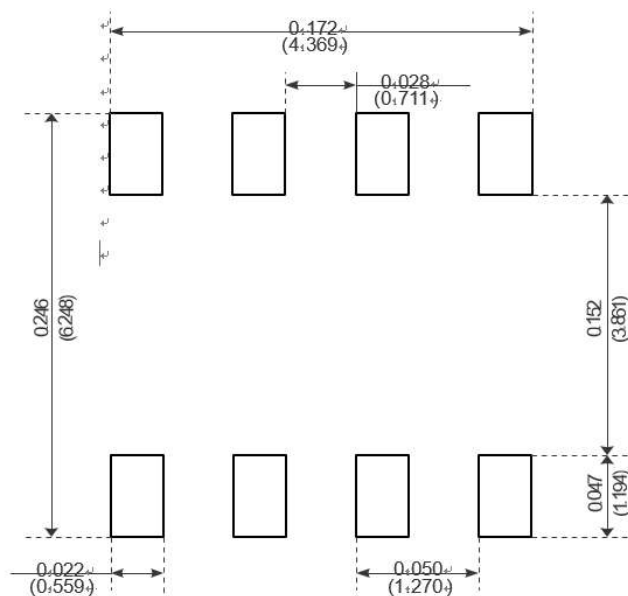

Figure.11: Maximum Effective Transient Thermal Impedance, Junction-to-Case

SOP-8



Symbol	Dimensions In Millimeters		Dimensions In Inches	
	Min	Max	Min	Max
A	1.350	1.750	0.053	0.069
A1	0.100	0.250	0.004	0.010
A2	1.350	1.550	0.053	0.061
b	0.330	0.510	0.013	0.020
c	0.170	0.250	0.006	0.010
D	4.700	5.100	0.185	0.200
E	3.800	4.000	0.150	0.157
E1	5.800	6.200	0.228	0.244
e	1.270 (BSC)		0.050 (BSC)	
L	0.400	1.270	0.016	0.050
θ	0°	8°	0°	8°



Recommended Minimum Pads