

120V N-CHANNEL ENHANCEMENT MODE MOSFET

MAIN CHARACTERISTICS

I_D	6A
V_{DSS}	120V
R_{DS(on)-typ(@V_{GS}=10V)}	< 180mΩ(Type:110 mΩ)

Application

- ◆Automotive lighting
- ◆Load switch
- ◆Uninterruptible power supply

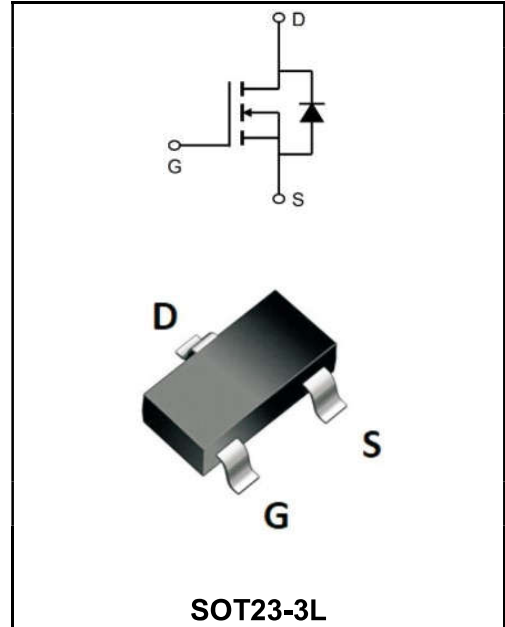

Product Specification Classification

Part Number	Package	Marking	Pack
YFW6N12MI	SOT23-3L	6N12-AP	3000PCS/Tape

Maximum Ratings at T_c=25°C unless otherwise specified

Characteristics	Symbols	Value	Units
Drain-Source Voltage	V_{DS}	120	V
Gate - Source Voltage	V_{GS}	±20	V
Continuous Drain Current, V _{GS} @ 10V @T _C =25°C	I_D	6	A
Continuous Drain Current, V _{GS} @ 10V @T _C =100°C	I_D	3.5	A
Pulsed Drain Current ¹	I_{DM}	18	A
Total Power Dissipation @T _C =25°C	P_D	30	W
Total Power Dissipation ³ @T _A =25°C	P_D	2.7	W
Storage Temperature Range	T_{STG}	-55 to +150	°C
Operating Junction Temperature Range	T_J	-55 to +150	°C
Maximum Thermal Resistance, Junction ambient	R_{θJA}	125	°C/W
Maximum Thermal Resistance, Junction-case	R_{θJC}	5.1	°C/W

Maximum Ratings at Tc=25°C unless otherwise specified

Characteristics	Test Condition	Symbols	Min	Typ	Max	Units
Drain-Source Breakdown Voltage	$V_{GS}=0V, I_D=250\mu A$	V(BR)DSS	100	135	-	V
Zero Gate Voltage Drain Current	$V_{DS}=100V, V_{GS}=0V$	I_{DSS}	-	-	1	μA
Gate to Body Leakage Current	$V_{GS}=\pm 20V, V_{DS}=0V$	I_{GSS}	-	-	±100	nA
Gate Threshold Voltage	$V_{DS}=V_{GS}, I_D=250\mu A$	V_{GS(th)}	1.2	2.0	2.5	V
Static Drain-Source on-Resistance note3	$V_{GS}=10V, I_D=5A$	R_{DS(ON)}	-	110	180	mΩ
	$V_{GS}=4.5V, I_D=3A$		-	120	200	
Forward Transconductance	$V_{DS}=5V, I_D=5A$	g_{fs}	-	14		S
Gate Resistance	$V_{DS}=0V, V_{GS}=0V, f=1MHz$	R_G	-	3		Ω
Input Capacitance	$V_{DS}=15V$ $V_{GS}=0V$ $f=1MHz$	C_{iss}	-	1100	-	pF
Output Capacitance		C_{oss}	-	55	-	
Reverse Transfer Capacitance		C_{rss}	-	40	-	
Total Gate Charge	$V_{GS}=10V$ $V_{DS}=50V$ $I_D=5A$	Q_g	-	11.9	-	nC
Gate-Source Charge		Q_{gs}	-	2.8	-	
Gate-Drain("Miller") Charge		Q_{gd}	-	1.7	-	
Turn-on delay time	$V_{GS}=10V$ $V_{DS}=30V$ $I_D=5A$ $R_G=1.8\Omega$	t_{d(on)}	-	3.8	-	
Turn-on Rise Time		T_r	-	25.8	-	
Turn-Off Delay Time		t_{d(OFF)}	-	16	-	
Turn-Off Fall Time		t_f	-	8.8	-	
Continuous Source Current ^{1,5}	$V_G=V_D=0V$, Force Current	I_S	-	-	14.6	A
Pulsed Source Current ^{2,5}		I_{SM}	-	-	25	A
Diode Forward Voltage ²	$V_{GS}=0V, I_S=10A$	V_{SD}	-	-	1.2	V

Note :

- 1、 The data tested by surface mounted on a 1 inch 2 FR-4 board with 2OZ copper.
- 2、 The data tested by pulsed , pulse width $\cong 300\mu s$, duty cycle $\cong 2\%$
- 3、 The power dissipation is limited by 150°C junction temperature
- 4、 The data is theoretically the same as I D and I DM , in real applications , should be limited by total power dissipation.

Ratings and Characteristic Curves

Typical Characteristics

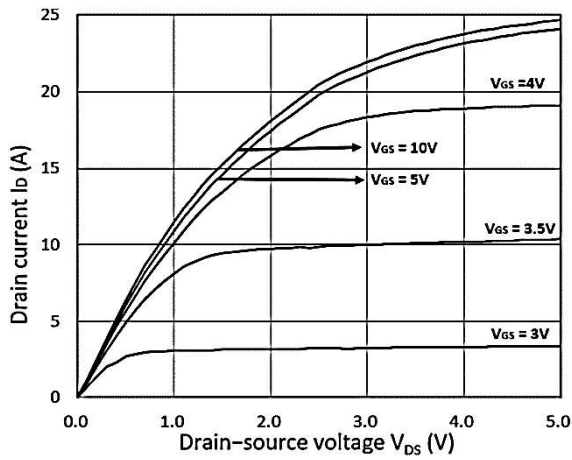

Figure 1. Output Characteristics

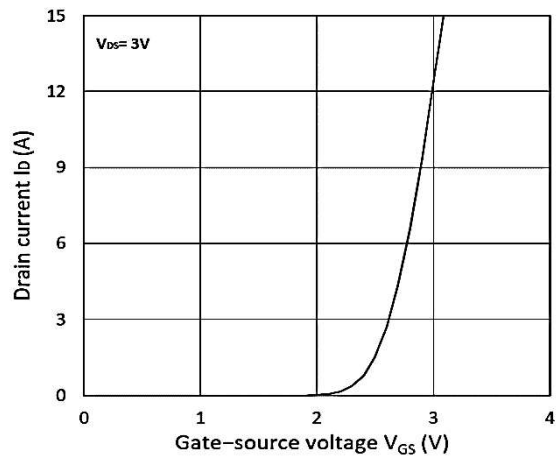

Figure 2. Transfer Characteristics

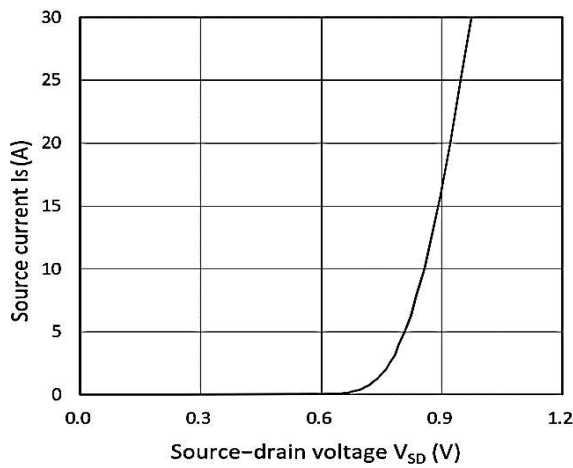

Figure 3. Forward Characteristics of Reverse

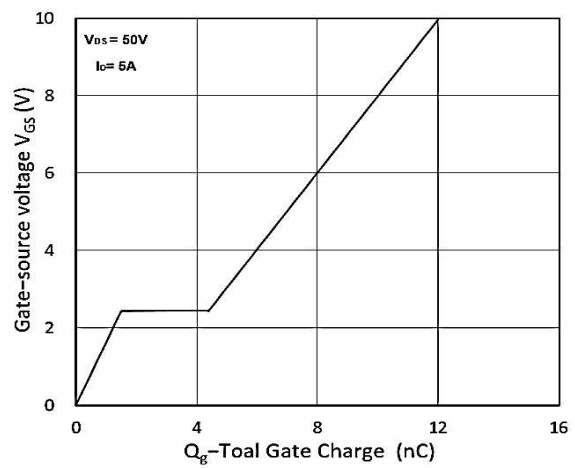

Figure 4. Gate Charge Characteristics

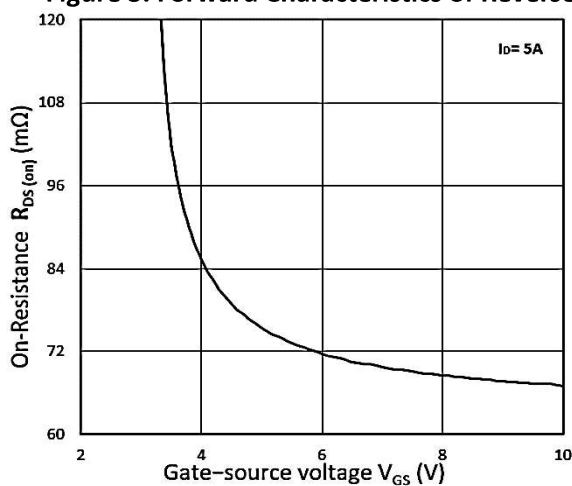

Figure 5. $R_{DS(on)}$ vs. V_{GS}

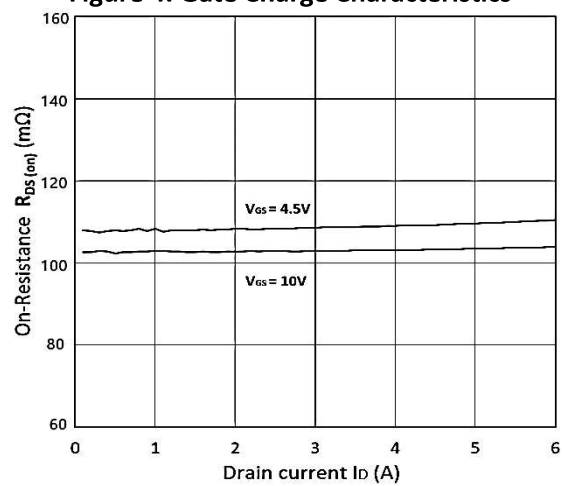

Figure 6. $R_{DS(on)}$ vs. I_D

Ratings and Characteristic Curves

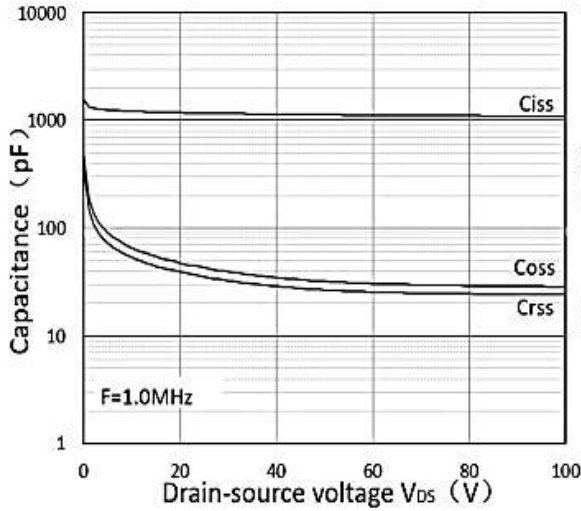

Figure 7. Capacitance Characteristics

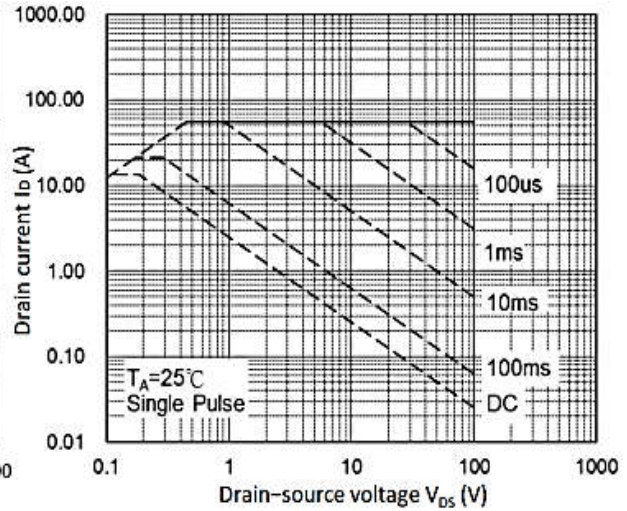

Figure 8. Safe Operating Area

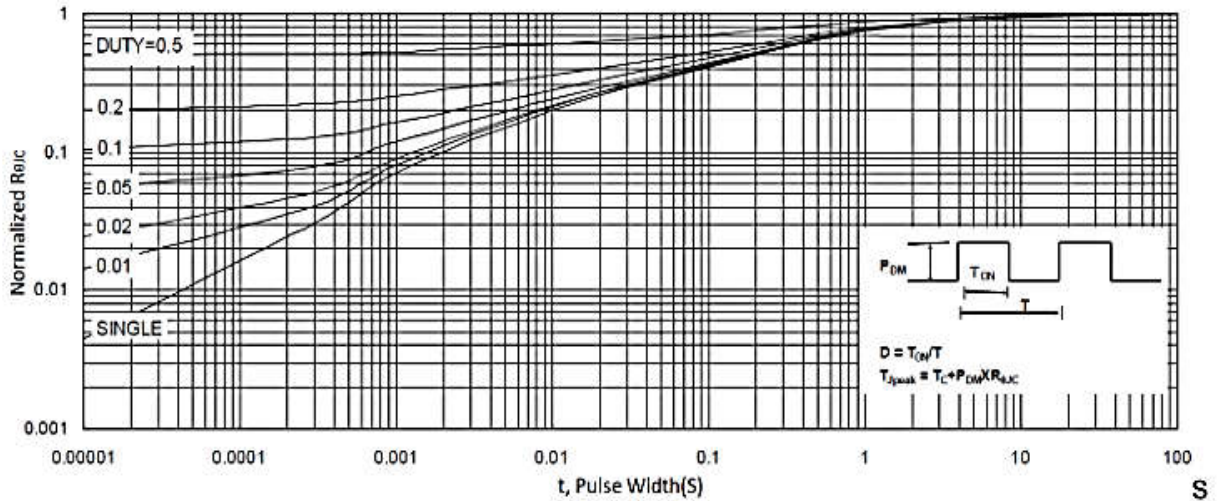

Figure 9. Normalized Maximum Transient Thermal Impedance

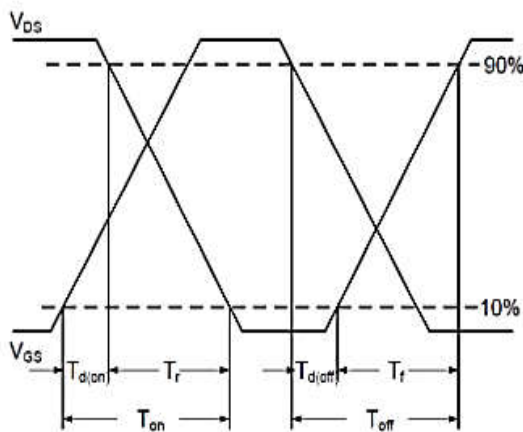

Figure 10. Switching Time Waveform

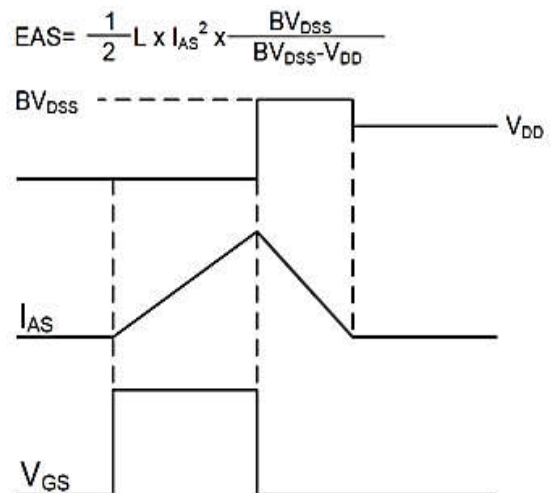
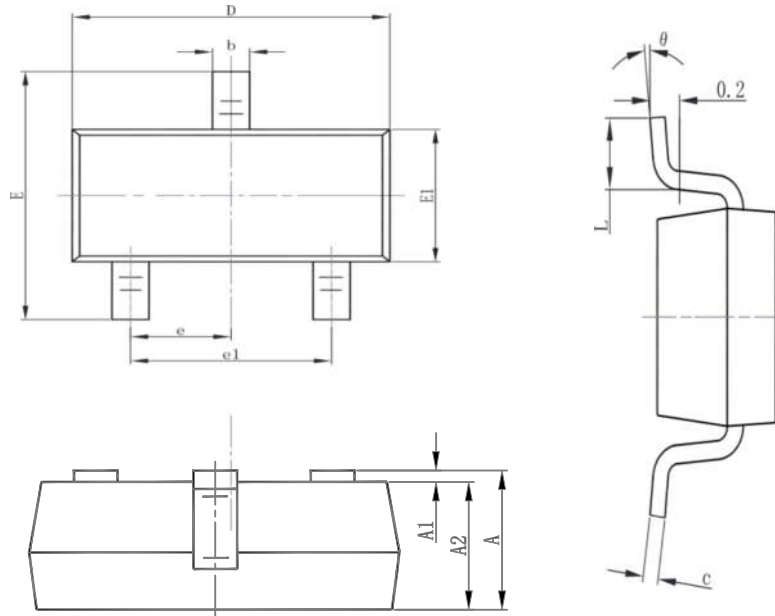

Figure 11. Unclamped Inductive Switching Waveform

SOT23-3L



Symbol	Dimensions In Millimeters		Dimensions In Inches	
	Min.	Max.	Min.	Max.
A	1.050	1.250	0.041	0.049
A1	0.000	0.100	0.000	0.004
A2	1.050	1.150	0.041	0.045
b	0.300	0.500	0.012	0.020
c	0.100	0.200	0.004	0.008
D	2.820	3.020	0.111	0.119
E1	1.500	1.700	0.059	0.067
E	2.650	2.950	0.104	0.116
e	0.950(BSC)		0.037(BSC)	
e1	1.800	2.000	0.071	0.079
L	0.300	0.600	0.012	0.024
θ	0°	8°	0°	8°