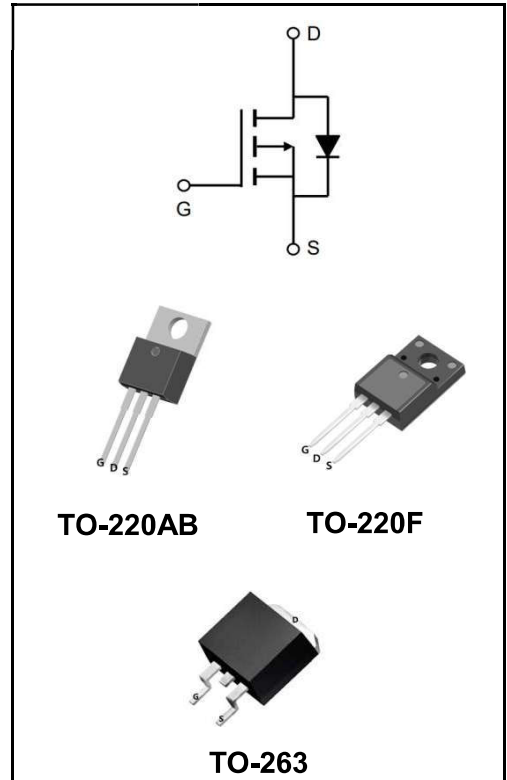

-60V P-CHANNEL ENHANCEMENT MODE MOSFET
MAIN CHARACTERISTICS

I_D	-45A
V_{DSS}	-60V
R_{DS(on)-typ}(@V_{GS}=-10V)	< -25mΩ (Type:20 mΩ)

Application

- ◆Lithium battery protection
- ◆Wireless impact
- ◆Mobile phone fast charging

Product Specification Classification

Part Number	Package	Marking	Pack
YFW45P06AT	TO-220AB	YFW 45P06AT XXXXX	1000PCS/Box
YFW45P06AF	TO-220F	YFW 45P06AF XXXXX	1000PCS/Box
YFW45P06AS	TO-263	YFW 45P06AS XXXXX	800PCS/Reel

Maximum Ratings at T_c=25°C unless otherwise specified

Characteristics	Symbols	Value	Units
Drain-Source Voltage	V_{DS}	-60	V
Gate - Source Voltage	V_{GS}	±20	V
Continuous Drain Current, V _{GS} @ -10V ¹ @T _C =25°C	I_D	-45	A
Continuous Drain Current, V _{GS} @ -10V ¹ @T _C =100°C	I_D	-28	A
Pulsed Drain Current ²	I_{DM}	-85	A
Single Pulse Avalanche Energy ³	E_{AS}	113	mJ
Avalanche Current	I_{AS}	47.6	A
Total Power Dissipation ⁴ @T _C =25°C	P_D	52.1	W
Storage Temperature Range	T_{STG}	-55 to +150	°C
Operating Junction Temperature Range	T_J	-55 to +150	°C
Thermal Resistance Junction-Ambient ¹	R_{θJA}	62	°C/W
Thermal Resistance Junction to Case ¹	R_{θJC}	2.4	°C/W

Maximum Ratings at Tc=25°C unless otherwise specified

Characteristics	Test Condition	Symbols	Min	Typ	Max	Units
Drain-Source Breakdown Voltage	$V_{GS}=0V, I_D=-250\mu A$	BV_{DSS}	-60	-68	-	V
BV_{DSS} Temperature Coefficient	Reference to 25°C, $I_D=-1mA$	$\Delta BV_{DSS}/\Delta T_J$	-	-0.035	-	V/°C
Static Drain-Source On-Resistance ²	$V_{GS}=-10V, I_D=-10A$	$R_{DS(ON)}$	-	20	25	mΩ
	$V_{GS}=-4.5V, I_D=-8A$		-	26	33	
Gate -Threshold Voltage	$V_{DS}=V_{GS}, I_D=-250\mu A$	$V_{GS(th)}$	-1.0	-1.6	-2.5	V
$V_{GS(th)}$ Temperature Coefficient		$\Delta V_{GS(th)}$	-	4.28	-	mV/°C
Drain-Source Leakage Current	$V_{DS}=-48V, V_{GS}=0V, T_J=25^\circ C$	I_{DSS}	-	-	1	μA
	$V_{DS}=-48V, V_{GS}=0V, T_J=55^\circ C$		-	-	5	
Gate -Source Leakage Current	$V_{GS}=\pm 20V, V_{DS}=0V$	I_{GSS}	-	-	±100	nA
Forward Transconductance	$V_{DS}=-10V, I_D=-18A$	g_{fs}	-	23	-	S
Gate Resistance	$V_{DS}=0V, V_{GS}=0V, f=1MHz$	R_g	-	7	-	Ω
Total Gate Charge(-4.5V)	$V_{DS}=-20V$ $V_{GS}=-4.5V$ $I_D=-12A$	Q_g	-	25	-	nC
Gate-Source Charge		Q_{gs}	-	6.7	-	
Gate-Drain Charge		Q_{gd}	-	5.5	-	
Turn-on delay time	$V_{DD}=-15V$ $V_{GS}=-10V$ $I_D=-1A$ $R_G=3.3\Omega$	$t_{d(on)}$	-	38	-	ns
Rise Time		T_r	-	23.6	-	
Turn-Off Delay Time		$t_{d(OFF)}$	-	100	-	
Fall Time		t_f	-	6.8	-	
Input Capacitance	$V_{DS}=-15V$ $V_{GS}=0V$ $f=1MHz$	C_{iss}	-	3635	-	pF
Output Capacitance		C_{oss}	-	224	-	
Reverse Transfer Capacitance		C_{rss}	-	141	-	
Continuous Source Current ^{1,5}	$V_G=V_D=0V, \text{Force Current}$	I_S	-	-	-35	A
Pulsed Source Current ^{2,5}		I_{SM}	-	-	-70	A
Diode Forward Voltage ²	$V_{GS}=0V, I_S=-1A, T_J=25^\circ C$	V_{SD}	-	-	-1	V

Note :

- 1、 The data tested by surface mounted on a 1 inch 2 FR-4 board with 2OZ copper.
- 2、 The data tested by pulsed , pulse width $\leq 300\mu s$, duty cycle $\leq 2\%$
- 3、 The EAS data shows Max. rating . The test condition is $V_{DD}=-48V, V_{GS}=-10V, L=0.1mH, I_{AS}=-47.6A$
- 4、 The power dissipation is limited by 150°C junction temperature
- 5、 The data is theoretically the same as I_D and I_{DM} , in real applications , should be limited by total power dissipation.

Ratings and Characteristic Curves

Typical Characteristics

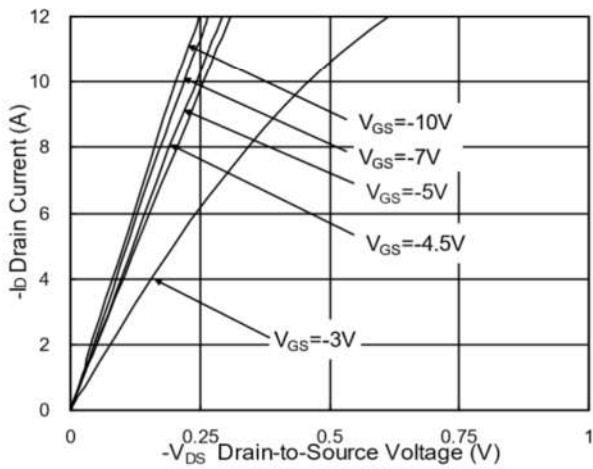

Fig.1 Typical Output Characteristics

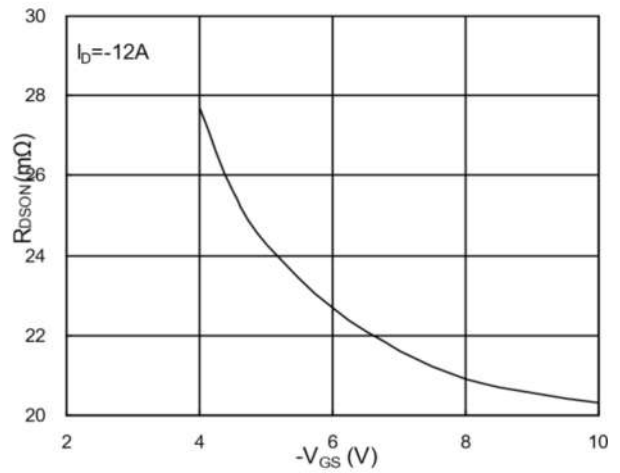

Fig.2 On-Resistance v.s Gate-Source

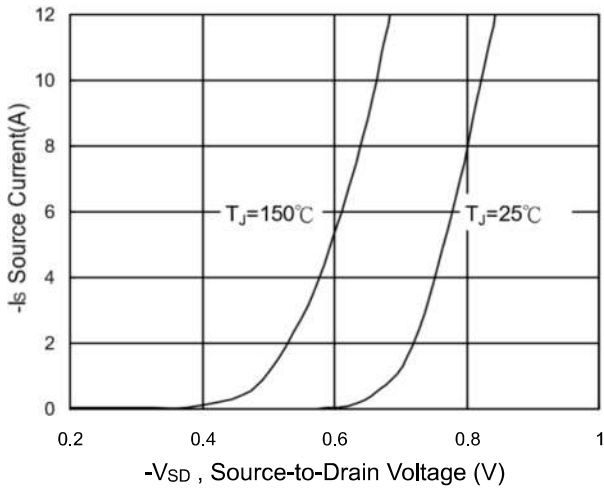

Fig.3 Forward Characteristics Of Reverse

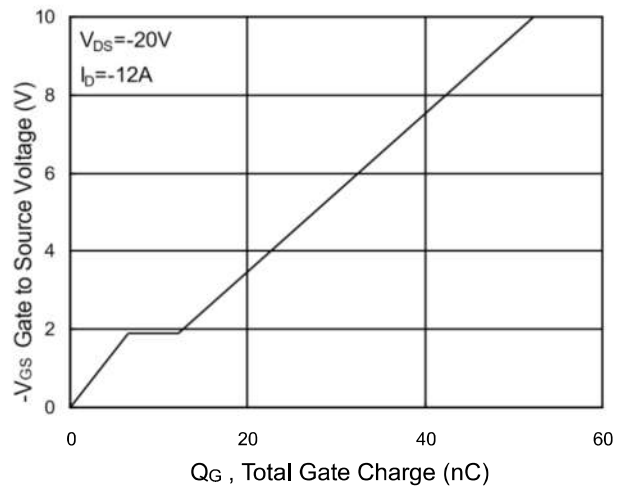

Fig.4 Gate-Charge Characteristics

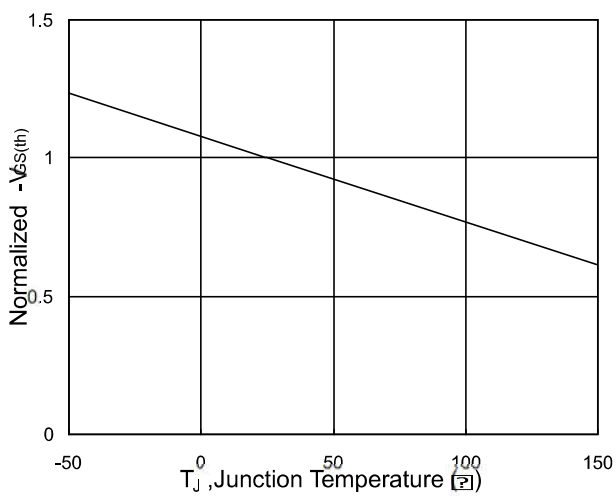

Fig.5 Normalized V_{GS(th)} v.s T_J

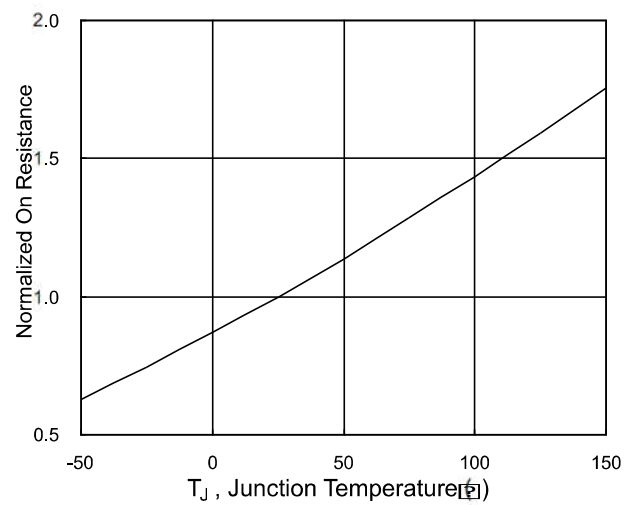

Fig.6 Normalized R_{DS(on)} v.s T_J

Ratings and Characteristic Curves

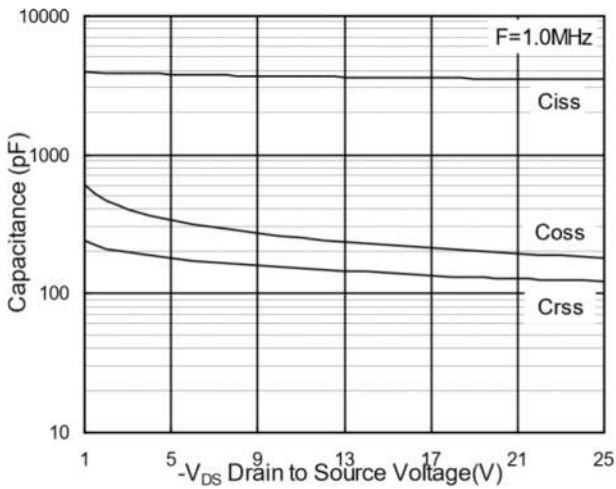

Fig.7 Capacitance

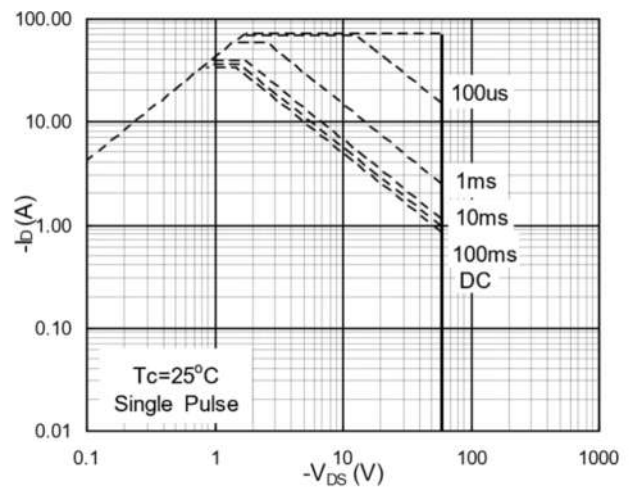

Fig.8 Safe Operating Area

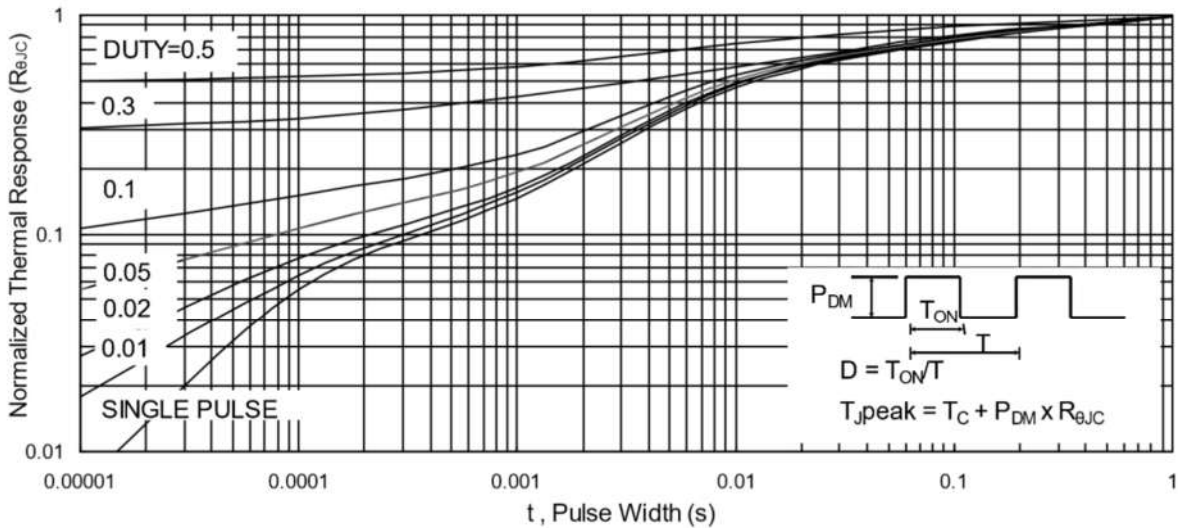

Fig.9 Normalized Maximum Transient Thermal Impedance

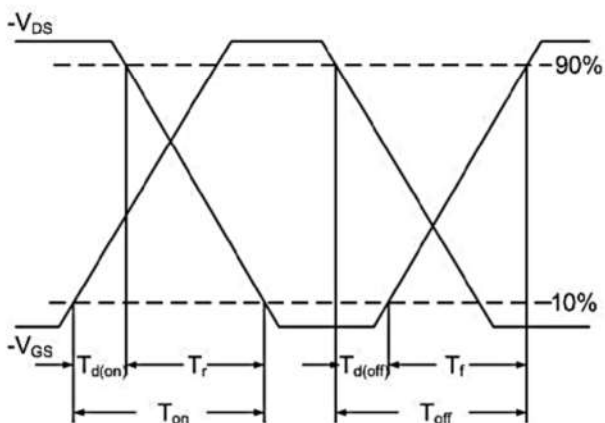

Fig.10 Switching Time Waveform

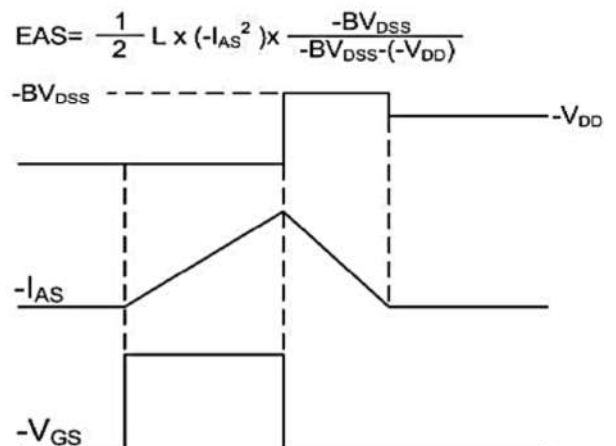

Fig.11 Unclamped Inductive Waveform

Package Outline Dimensions Millimeters

TO-220AB

Dim.	Min.	Max.
A	10.15	10.35
B	2.65	2.5
C	3.70	3.0
D	28.5	2.5
E	1.30	1.45
F	6.35	6.55
G	2.	3.3
H	15.0	16.0
I	0.38	0.42
J	4.45	4.55
K	1.25	1.35
L	Typ 5.08	
M	Typ 2.54	
N	3.1	3.3
O	0.76	0.84
All Dimensions in millimeter		

TO-220F

Dim.	Min.	Max.
A	.5	10.25
B	2.5	3.25
C	1.25	1.45
D	12.5	13.25
E	0.50	0.65
F	3.1	3.3
G	1.30	1.45
H	Typ 2.54	
I	Typ 5.08	
J	4.60	4.75
K	2.50	2.65
L	6.35	6.55
M	15.4	16.0
N	2.75	3.05
O	0.48	0.52
P	0.76	0.84
All Dimensions in millimeter		

Package Outline Dimensions Millimeters

TO-263

	Dim.	Min.	Max.
	A	10.1	10.2
	B	7.4	7.6
	C	1.3	1.5
	D	0.55	0.75
	E	5.0	6.0
	F	1.4	1.6
	G	0.78	0.86
	H	1.2	1.3
	I	Typ2.54	
	J	8.4	8.6
	K	4.45	4.55
	L	1.25	1.35
	M	0.02	0.1
	N	2.4	2.8
O	0.36	0.40	
All Dimensions in millimeter			