

40V N-CHANNEL ENHANCEMENT MODE MOSFET

MAIN CHARACTERISTICS

I_D	120A
V_{DSS}	40V
R_{DS(on)-typ(@V_{GS}=10V)}	< 3.2mΩ (Type:2.5 mΩ)

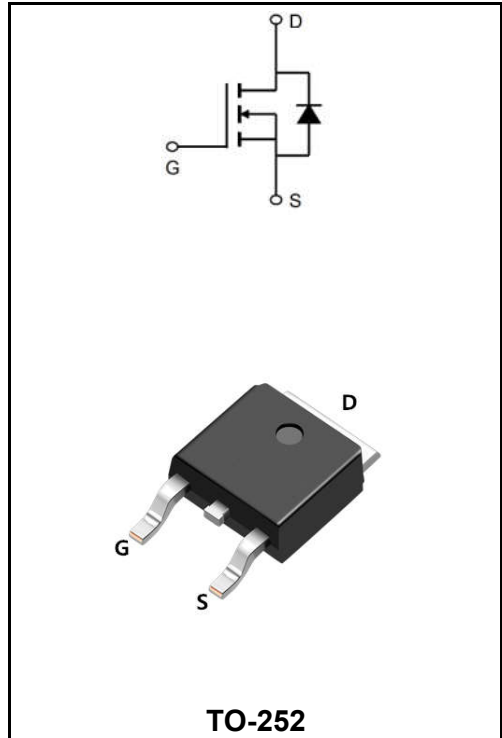

Application

- ◆ Battery protection
- ◆ Load switch
- ◆ Uninterruptible power supply

Product Specification Classification

Part Number	Package	Marking	Pack
YFW120N04AD	TO-252	YFW 120N04AD XXXXX	2500PCS/Tape

Maximum Ratings at T_c=25°C unless otherwise specified

Characteristics	Symbols	Value	Units
Drain-Source Voltage	V_{DS}	40	V
Gate - Source Voltage	V_{GS}	±20	V
Continuous Drain Current, V _{GS} @ 10V ¹ @T _c =25°C	I_D	120	A
Continuous Drain Current, V _{GS} @ 10V ¹ @T _c =100°C	I_D	85	A
Pulsed Drain Current ²	I_{DM}	360	A
Single Pulse Avalanche Energy ³	E_{AS}	145	mJ
Avalanche Current	I_{AS}	57	A
Total Power Dissipation ⁴ @T _c =25°C	P_D	22	W
Storage Temperature Range	T_{STG}	-55 to +150	°C
Operating Junction Temperature Range	T_J	-55 to +150	°C
Thermal Resistance Junction-Ambient ¹	R_{θJA}	55	°C/W
Thermal Resistance Junction-Case ¹	R_{θJC}	1.7	°C/W

Maximum Ratings at Tc=25°C unless otherwise specified

Characteristics	Test Condition	Symbols	Min	Typ	Max	Units
Drain-Source Breakdown Voltage	$V_{GS}=0V, I_D=250\mu A$	BV_{DSS}	40	-	-	V
Static Drain-Source On-Resistance ²	$V_{GS}=10V, I_D=20A$	$R_{DS(on)}$	-	2.5	3.2	mΩ
	$V_{GS}=4.5V, I_D=15A$		-	3.8	5.3	
Gate -Threshold Voltage	$V_{DS}=V_{GS}, I_D=250\mu A$	$V_{GS(th)}$	1.2	1.7	2.2	V
Drain -Source Leakage Current	$V_{DS}=40V, V_{GS}=0V, T_J=25^\circ C$	I_{DSS}	-	-	1	μA
	$V_{DS}=40V, V_{GS}=0V, T_J=55^\circ C$		-	-	5	
Gate-Source Leakage Current	$V_{GS}=\pm 20V, V_{DS}=0V$	I_{GSS}	-	-	±100	nA
Forward Transconductance	$V_{DS}=5V, I_D=20A$	g_{FS}	-	75	-	S
Gate Resistance	$V_{DS}=0V, V_{GS}=0V, f=1MHz$	R_g	-	1.5	-	Ω
Total Gate Charge(4.5V)	$V_{DS}=20V$ $V_{GS}=4.5V$ $I_D=20A$	Q_g	-	22.7	-	nC
Gate-Source Charge		Q_{GS}	-	7.5	-	
Gate-Drain Charge		Q_{gd}	-	5.5	-	
Turn-on delay time	$V_{DD}=20V$ $V_{GS}=10V$ $R_G=3\Omega$ $I_D=20A$	$t_{d(on)}$	-	10	-	ns
Rise Time		T_r	-	5	-	
Turn-Off Delay Time		$t_{d(OFF)}$	-	33	-	
Fall Time		t_f	-	6.5	-	
Input Capacitance	$V_{DS}=20V$ $V_{GS}=0V$ $f=1.0MHz$	C_{iss}	-	2648	-	pF
Output Capacitance		C_{oss}	-	899	-	
Reverse Transfer Capacitance		C_{rss}	-	71	-	
Continuous Source Current ^{1,6}	$V_G=V_D=0V, \text{Force Current}$	I_S	-	-	30	A
Diode Forward Voltage ²	$V_{GS}=0V, I_S=1A, T_J=25^\circ C$	V_{SD}	-	-	1	V

Note :

- 1.The data tested by surface mounted on a 1 inch 2 FR-4 board with 2OZ copper.
- 2.The data tested by pulsed , pulse width $\leq 300\mu s$, duty cycle $\leq 2\%$
- 3.The EAS data shows Max. rating . The test condition is $V_{DD}=25V, V_{GS}=10V, L=0.1mH, I_{AS}=54A$
- 4.The power dissipation is limited by 150°C junction temperature
- 5.The data is theoretically the same as I_D and I_{DM} , in real applications , should be limited by total power dissipation.

Ratings and Characteristic Curves

N-Channel Typical Characteristics

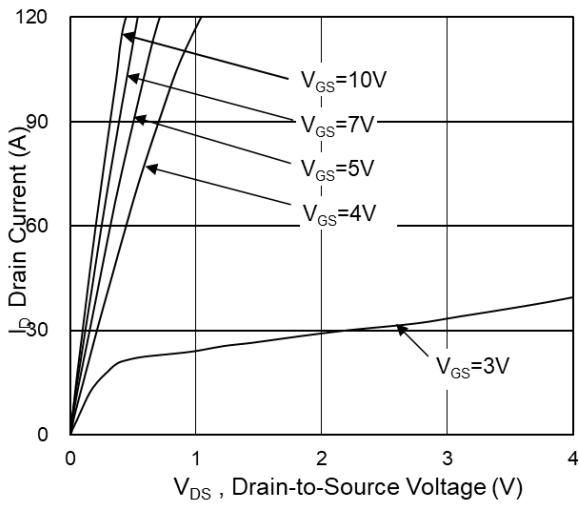

Fig.1 Typical Output Characteristics

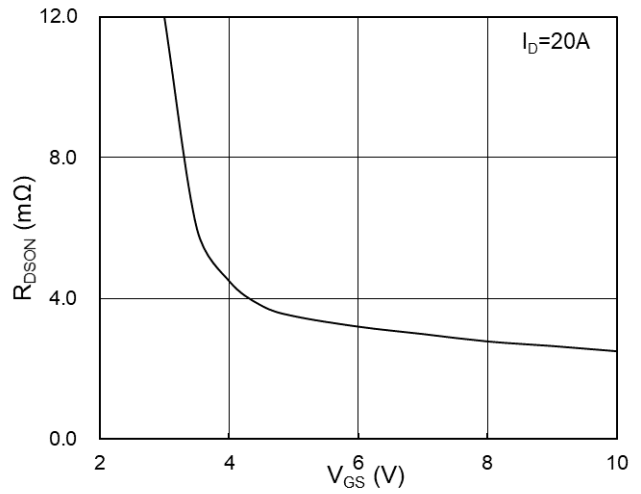

Fig.2 On-Resistance vs G-S Voltage

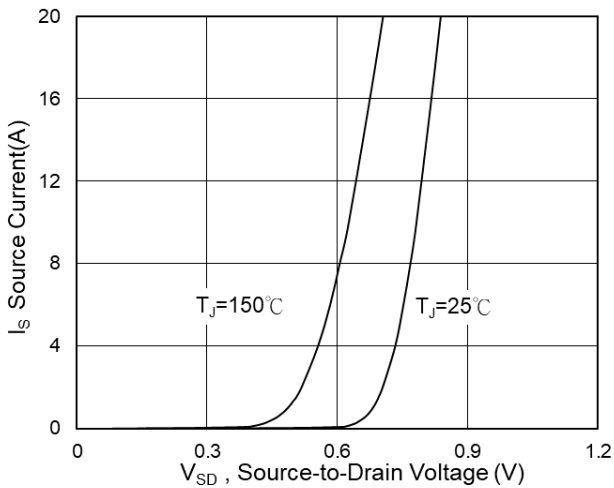

Fig.3 Source Drain Forward Characteristics

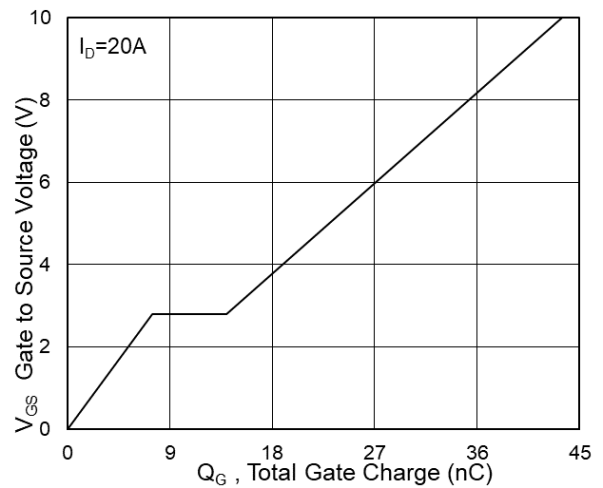

Fig.4 Gate-Charge Characteristics

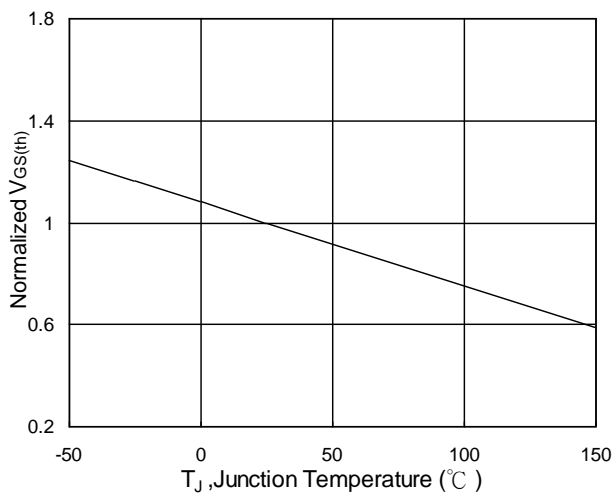

Fig.5 Normalized $V_{GS(th)}$ vs T_J

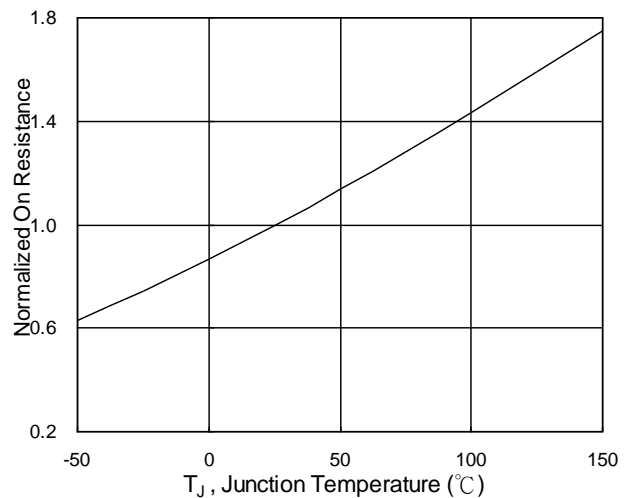

Fig.6 Normalized $R_{DS(on)}$ vs T_J

Ratings and Characteristics Curves

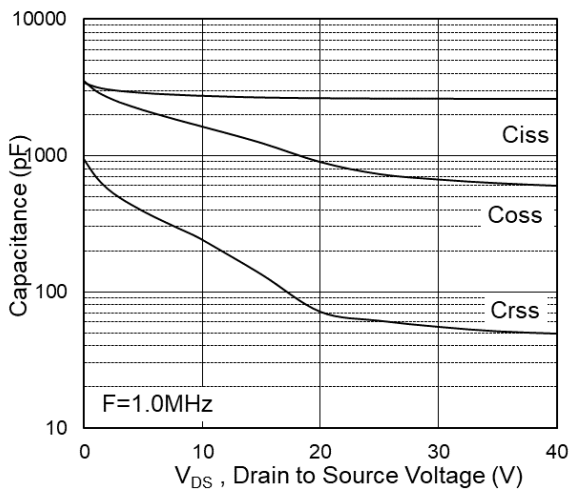

Fig.7 Capacitance

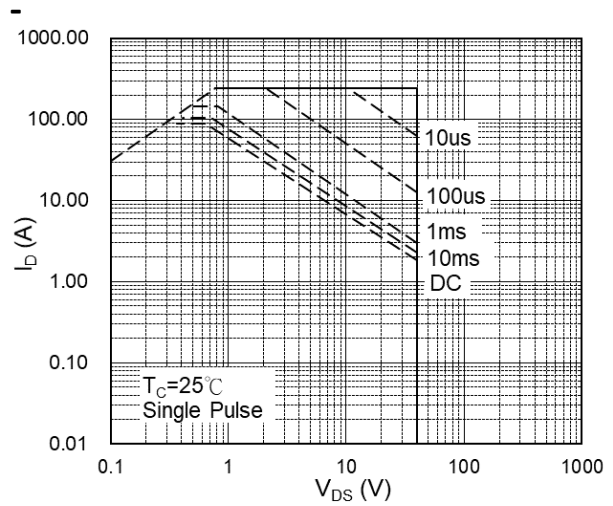

Fig.8 Safe Operating Area

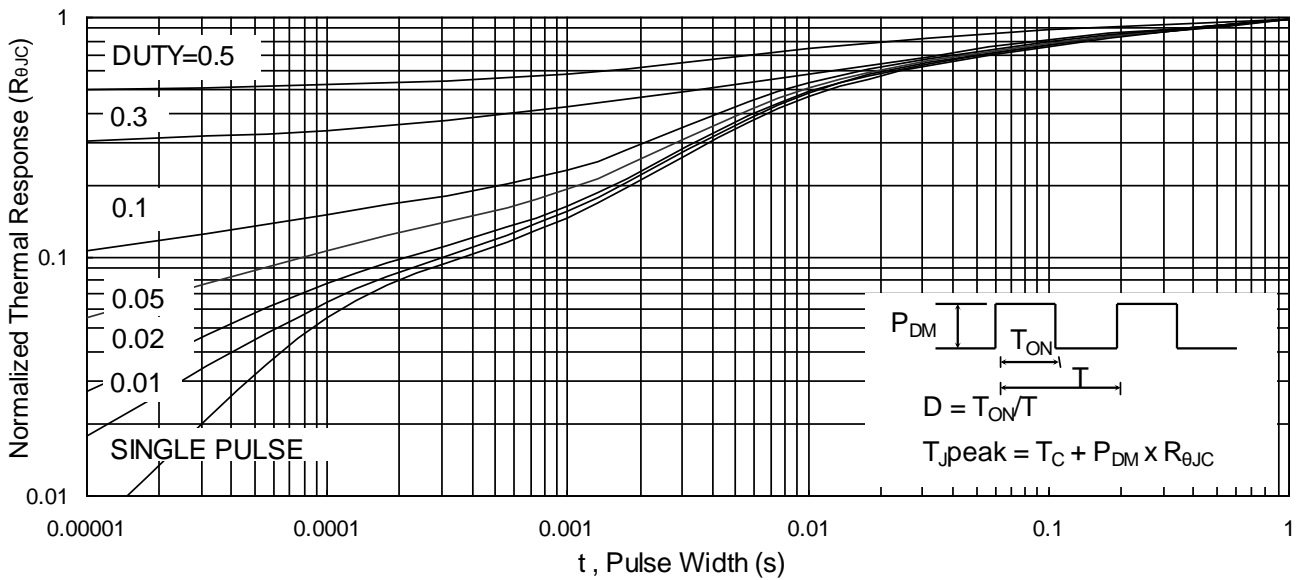

Fig.9 Normalized Maximum Transient Thermal Impedance

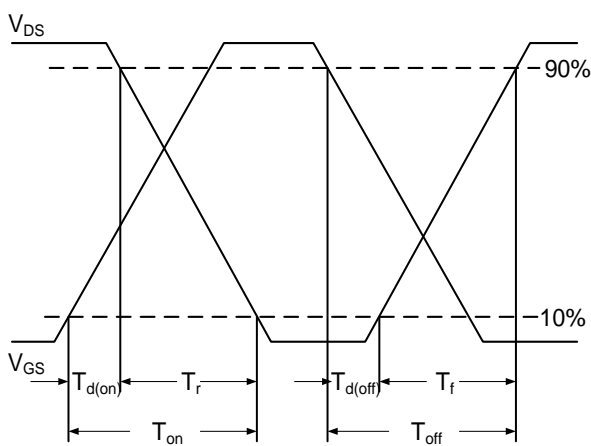

Fig.10 Switching Time Waveform

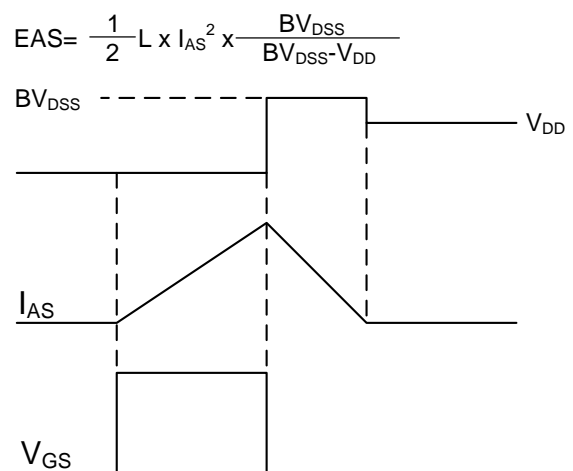

Fig.11 Unclamped Inductive Switching Wave

Package Outline Dimensions Millimeters

TO-252

Dim.	Min.	Typ.	Max.
A	2.10	-	2.50
A2	0	-	0.10
B	0.66	-	0.86
B2	5.18	-	5.48
C	0.40	-	0.60
C2	0.44	-	0.58
D	5.90	-	6.30
D1	5.30REF		
E	6.40	-	6.80
E1	4.63	-	-
G	4.47	-	4.67
H	9.50	-	10.70
L	1.09	-	1.21
L2	1.35	-	1.65
V1	-	7°	-
V2	0°	-	6°
All Dimensions in millimeter			

