

**120V N-CHANNEL ENHANCEMENT MODE MOSFET**

**MAIN CHARACTERISTICS**

<b>I<sub>D</sub></b>	15A
<b>V<sub>DSS</sub></b>	120V
<b>R<sub>DS(on)-typ(@V<sub>GS</sub>=10V)</sub></b>	< 150mΩ ( <b>Type:105 mΩ</b> )

**Application**

- ◆Automotive lighting
- ◆Load switch
- ◆Uninterruptible power supply

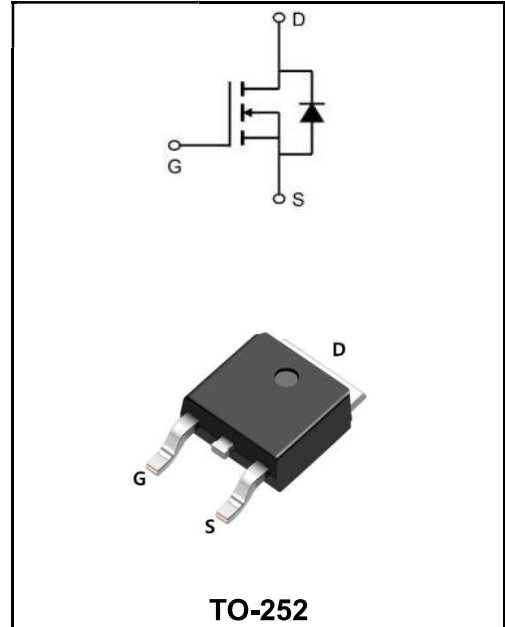

**Product Specification Classification**

Part Number	Package	Marking	Pack
YFW15N12AD	TO-252	YFW 15N12AD XXXXX	2500PCS/Tape

**Maximum Ratings at T<sub>c</sub>=25°C unless otherwise specified**

Characteristics	Symbols	Value	Units
Drain-Source Voltage	<b>V<sub>DS</sub></b>	120	<b>V</b>
Gate - Source Voltage	<b>V<sub>GS</sub></b>	±20	<b>V</b>
Drain Current, V <sub>GS</sub> @ 10V @T <sub>C</sub> =25°C	<b>I<sub>D</sub></b>	15	<b>A</b>
Drain Current, V <sub>GS</sub> @ 10V @T <sub>C</sub> =100°C	<b>I<sub>D</sub></b>	7.5	<b>A</b>
Pulsed Drain Current <sup>1</sup>	<b>I<sub>D, pulse</sub></b>	45	<b>A</b>
Total Power Dissipation @T <sub>C</sub> =25°C	<b>P<sub>D</sub></b>	30	<b>W</b>
Total Power Dissipation <sup>3</sup> @T <sub>A</sub> =25°C	<b>P<sub>D</sub></b>	2.7	<b>W</b>
Storage Temperature Range	<b>T<sub>STG</sub></b>	-55 to +150	<b>°C</b>
Operating Junction Temperature Range	<b>T<sub>J</sub></b>	-55 to +150	<b>°C</b>
Maximum Thermal Resistance, Junction ambient	<b>R<sub>θJA</sub></b>	62.5	<b>°C/W</b>
Maximum Thermal Resistance, Junction-case	<b>R<sub>θJC</sub></b>	5.1	<b>°C/W</b>

**Maximum Ratings at Tc=25°C unless otherwise specified**

Characteristics	Test Condition	Symbols	Min	Typ	Max	Units
Drain-Source Breakdown Voltage	$V_{GS}=0V, I_D=250\mu A$	<b>V(BR)DSS</b>	120	135	-	<b>V</b>
Zero Gate Voltage Drain Current	$V_{DS}=100V, V_{GS}=0V$	<b>I<sub>DSS</sub></b>	-	-	1.0	<b>μA</b>
Gate to Body Leakage Current	$V_{GS}=\pm 20V, V_{DS}=0V$	<b>I<sub>GSS</sub></b>	-	-	±100	<b>nA</b>
Gate Threshold Voltage	$V_{DS}=V_{GS}, I_D=250\mu A$	<b>V<sub>GS(th)</sub></b>	1.2	2.0	2.5	<b>V</b>
Static Drain-Source on-Resistance note3	$V_{GS}=10V, I_D=5A$	<b>R<sub>DS(ON)</sub></b>	-	105	150	<b>mΩ</b>
	$V_{GS}=4.5V, I_D=5A$		-	120	180	
Forward Transconductance	$V_{DS}=5V, I_D=5A$	<b>g<sub>FS</sub></b>	-	14	-	<b>S</b>
Gate Resistance	$V_{DS}=0V, V_{GS}=0V, f=1MHz$	<b>R<sub>g</sub></b>	-	3	-	<b>Ω</b>
Input Capacitance	$V_{DS}=15V$ $V_{GS}=0V$ $f=1.0MHz$	<b>C<sub>iss</sub></b>	-	1100	-	<b>pF</b>
Output Capacitance		<b>C<sub>oss</sub></b>	-	55	-	
Reverse Transfer Capacitance		<b>C<sub>rss</sub></b>	-	40	-	
Total Gate Charge	$V_{DS}=50V$ $V_{GS}=10V$ $I_D=5A$	<b>Q<sub>g</sub></b>	-	11.9	-	<b>nC</b>
Gate-Source Charge		<b>Q<sub>gs</sub></b>	-	2.8	-	
Gate-Drain("Miller") Charge		<b>Q<sub>gd</sub></b>	-	1.7	-	
Turn-on delay time	$V_{DS}=30V$ $I_D=5A$ $R_G=1.8\Omega$ $V_{GS}=10V$	<b>t<sub>d(on)</sub></b>	-	3.8	-	<b>ns</b>
Turn-on Rise Time		<b>T<sub>r</sub></b>	-	25.8	-	
Turn-Off Delay Time		<b>t<sub>d(OFF)</sub></b>	-	16	-	
Turn-Off Fall Time		<b>t<sub>f</sub></b>	-	8.8	-	
Continuous Source Current <sup>1,5</sup>	$V_G=V_D=0V, \text{ Force Current}$	<b>I<sub>S</sub></b>	-	-	14.6	<b>A</b>
Pulsed Source Current <sup>2,5</sup>		<b>I<sub>SM</sub></b>	-	-	25	<b>A</b>
Diode Forward Voltage <sup>2</sup>	$V_{GS}=0V, I_S=10A$	<b>V<sub>SD</sub></b>	-	-	1.2	<b>V</b>

Note :

- 1、 The data tested by surface mounted on a 1 inch 2 FR-4 board with 2OZ copper.
- 2、 The EAS data shows Max. rating . The test condition is T<sub>J</sub>=25°C, V<sub>DD</sub>=72V, V<sub>G</sub>=10V, L=0.1mH, R<sub>g</sub>=25Ω, I<sub>AS</sub>=8A
- 3、 The data tested by pulsed , pulse width  $\leq 300\mu s$  , duty cycle  $\leq 2\%$
- 4、 The power dissipation is limited by 150°C junction temperature
- 5、 The data is theoretically the same as I<sub>D</sub> and I<sub>DM</sub> , in real applications , should be limited by total power dissipation.

**Ratings and Characteristic Curves**

**Typical Characteristics**

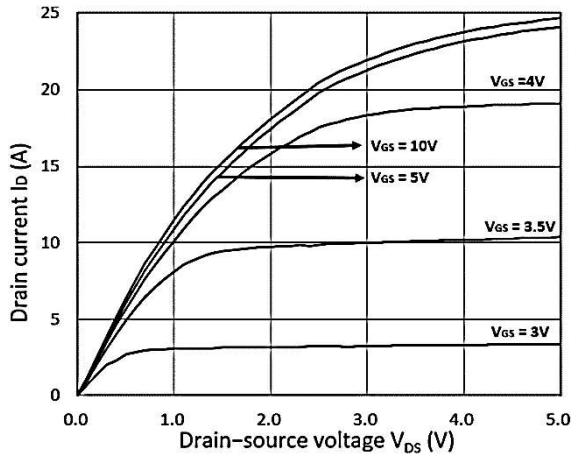

**Figure 1. Output Characteristics**

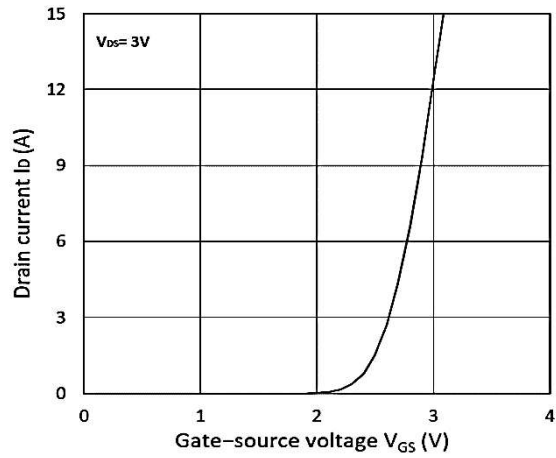

**Figure 2. Transfer Characteristics**

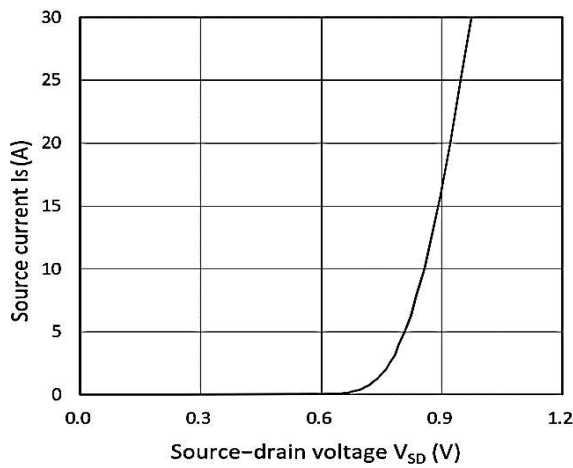

**Figure 3. Forward Characteristics of Reverse**

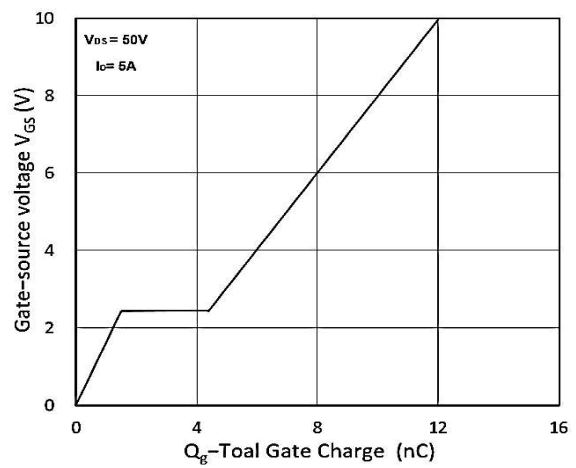

**Figure 4. Gate Charge Characteristics**

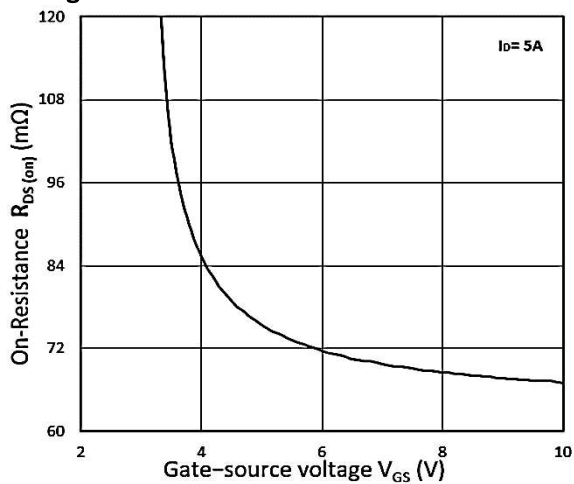

**Figure 5.  $R_{DS(on)}$  vs.  $V_{GS}$**

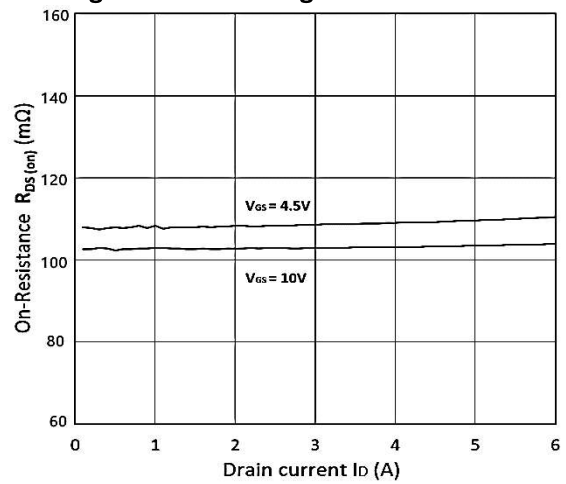

**Figure 6.  $R_{DS(on)}$  vs.  $I_D$**

Ratings and Characteristic Curves

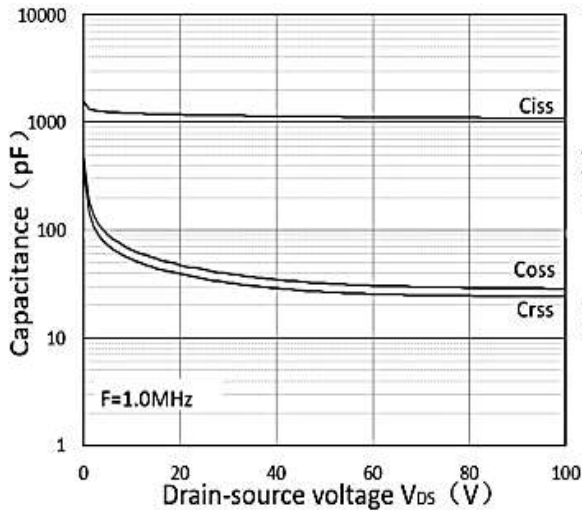

Figure 7. Capacitance Characteristics

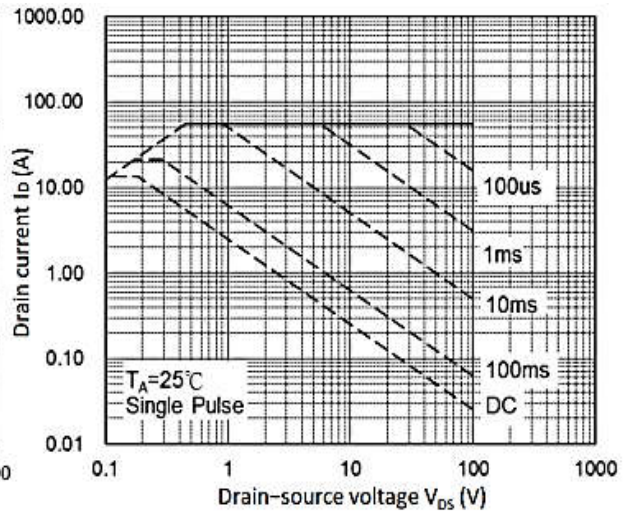

Figure 8. Safe Operating Area

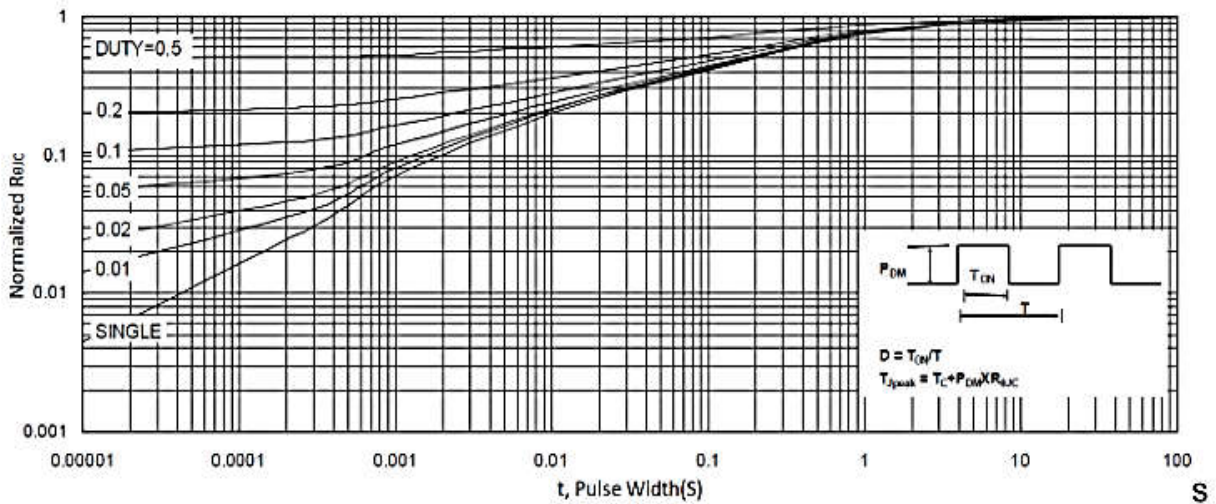

Figure 9. Normalized Maximum Transient Thermal Impedance

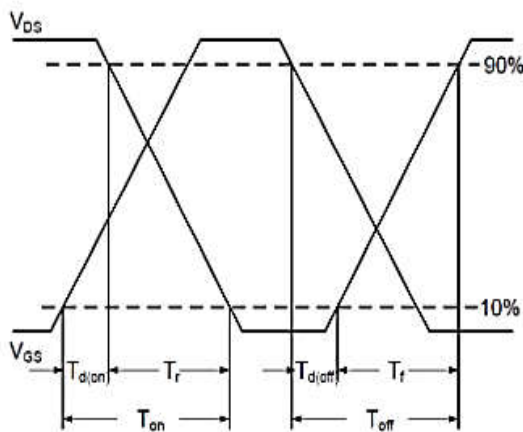

Figure 10. Switching Time Waveform

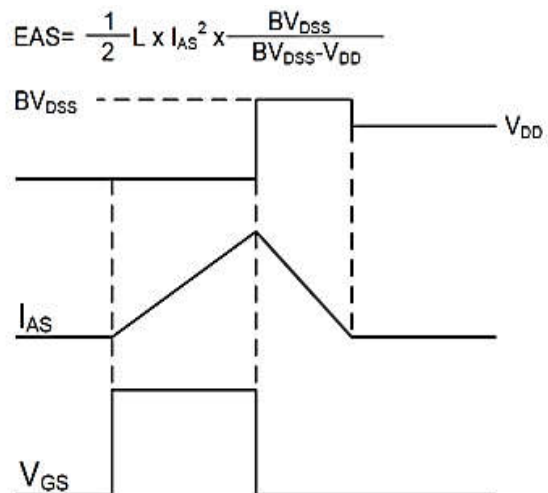

Figure 11. Unclamped Inductive Switching Waveform

Package Outline Dimensions Millimeters

TO-252

Dim.	Min.	Typ.	Max.
A	2.10	-	2.50
A2	0	-	0.10
B	0.66	-	0.86
B2	5.18	-	5.48
C	0.40	-	0.60
C2	0.44	-	0.58
D	5.90	-	6.30
D1	5.30REF		
E	6.40	-	6.80
E1	4.63	-	-
G	4.47	-	4.67
H	9.50	-	10.70
L	1.09	-	1.21
L2	1.35	-	1.65
V1	-	7°	-
V2	0°	-	6°
All Dimensions in millimeter			

