

-60V P-CHANNEL ENHANCEMENT MODE MOSFET

MAIN CHARACTERISTICS

I_D	-15A
V_{DSS}	-60V
R_{DS(on)-typ(@V_{GS}=10V)}	< 85mΩ (Type:68 mΩ)

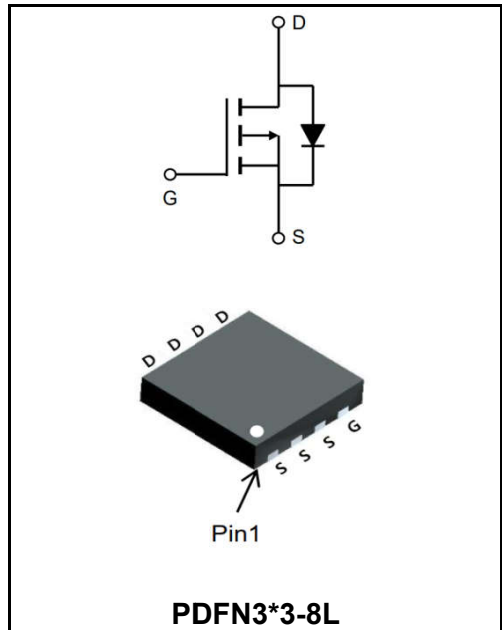

Application

- ◆ Brushless motor
- ◆ Load switch
- ◆ Uninterruptible power supply

Product Specification Classification

Part Number	Package	Marking	Pack
YFW15P06DF	PDFN3*3-8L	YFW 15P06DF XXXXX	5000PCS/Tape

Maximum Ratings at T_c=25°C unless otherwise specified

Characteristics	Symbols	Value	Units
Drain-Source Voltage	V_{DS}	-60	V
Gate - Source Voltage	V_{GS}	±20	V
Continuous Drain Current, V _{GS} @ -10V ¹ @T _c =25°C	I_D	-15	A
Continuous Drain Current, V _{GS} @ -10V ¹ @T _c =100°C	I_D	-8.3	A
Pulsed Drain Current ²	I_{DM}	-30	A
Single Pulse Avalanche Energy ³	E_{AS}	29.8	mJ
Total Power Dissipation ⁴ @T _c =25°C	P_D	31.3	W
Total Power Dissipation ⁴ @T _A =25°C	P_D	2	W
Storage Temperature Range	T_{STG}	-55 to +150	°C
Operating Junction Temperature Range	T_J	-55 to +150	°C
Thermal Resistance Junction-Ambient ¹	R_{θJA}	25	°C/W
Thermal Resistance Junction-Case ¹	R_{θJC}	4.0	°C/W

Maximum Ratings at Tc=25°C unless otherwise specified

Characteristics	Test Condition	Symbols	Min	Typ	Max	Units
Drain-Source Breakdown Voltage	$V_{GS}=0V, I_D=-250\mu A$	BV_{DSS}	-60	-	-	V
BV_{DSS} Temperature Coefficient	Reference to 25°C, $I_D=-1mA$	$\Delta BV_{DSS}/\Delta T_J$	-	-0.03	-	V/°C
Static Drain-Source On-Resistance ²	$V_{GS}=-10V, I_D=-3A$	$R_{DS(ON)}$	-	68	85	mΩ
	$V_{GS}=-4.5V, I_D=-2A$		-	90	110	
Gate -Threshold Voltage	$V_{DS}=V_{GS}, I_D=-250\mu A$	$V_{GS(th)}$	-1.2	1.75	-2.5	V
Drain-Source Leakage Current	$V_{DS}=-48V, V_{GS}=0V, T_J=25^\circ C$	I_{DSS}	-	-	-1	μA
	$V_{DS}=-48V, V_{GS}=0V, T_J=55^\circ C$		-	-	-5	
Gate -Source Leakage Current	$V_{GS}=\pm 20V, V_{DS}=0V$	I_{GSS}	-	-	±100	nA
Forward Transconductance	$V_{DS}=-5V, I_D=-3A$	g_{fs}	-	8.5	-	S
Total Gate Charge(-4.5V)	$V_{DS}=-48V$ $V_{GS}=-4.5V$ $I_D=-3A$	Q_g	-	12.1	-	nC
Gate-Source Charge		Q_{gs}	-	2.2	-	
Gate-Drain Charge		Q_{gd}	-	6.3	-	
Turn-on delay time	$V_{DD}=-15V$ $V_{GS}=-10V$ $I_D=-1A$ $R_G=3.3$	$t_{d(on)}$	-	9.2	-	ns
Rise Time		T_r	-	20.1	-	
Turn-Off Delay Time		$t_{d(OFF)}$	-	46.7	-	
Fall Time		t_f	-	9.4	-	
Input Capacitance	$V_{DS}=-15V$ $V_{GS}=0V$ $f=1MHz$	C_{iss}	-	1137	-	pF
Output Capacitance		C_{oss}	-	76	-	
Reverse Transfer Capacitance		C_{rss}	-	50	-	
Continuous Source Current ^{1,5}	$V_G=V_D=0V$, Force Current	I_S	-	-	-13	A
Diode Forward Voltage ²	$V_{GS}=0V, I_S=-1A, T_J=25^\circ C$	V_{SD}	-	-	-1.2	V

Note :

- 1、 The data tested by surface mounted on a 1 inch 2 FR-4 board with 2OZ copper.
- 2、 The data tested by pulsed , pulse width $\cong 300\mu s$, duty cycle $\cong 2\%$
- 3、 The EAS data shows Max. rating . The test condition is $V_{DD}=-25V, V_{GS}=-10V, L=0.1mH, I_{AS}=-24A$
- 4、 The power dissipation is limited by 150°C junction temperature
- 5、 The data is theoretically the same as I D and I DM , in real applications , should be limited by total power dissipation.

Ratings and Characteristic Curves

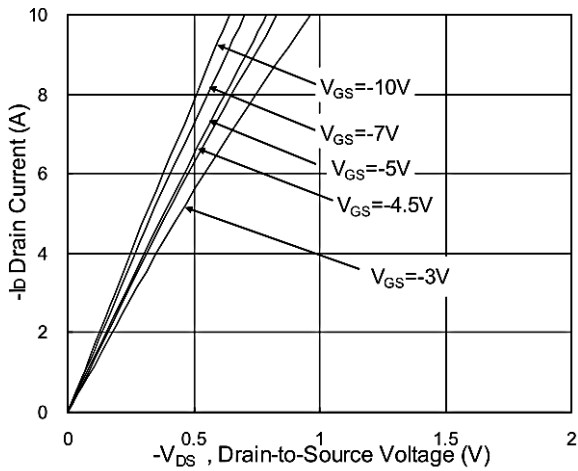

Fig.1 Typical Output Characteristics

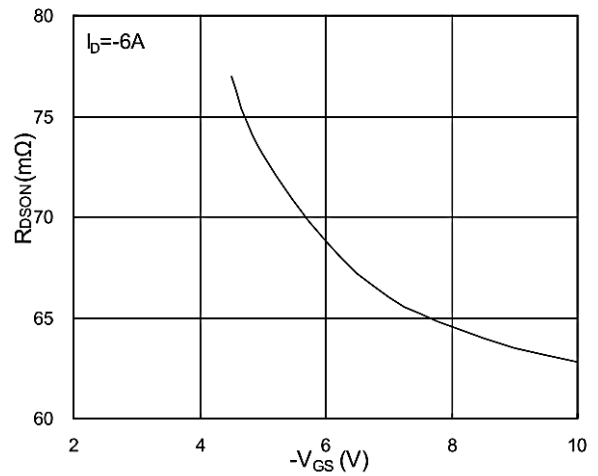

Fig.2 On-Resistance v.s Gate-Source

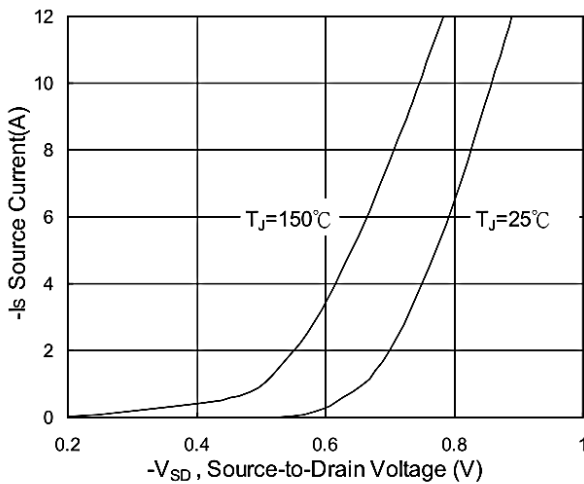

Fig.3 Forward Characteristics of Reverse

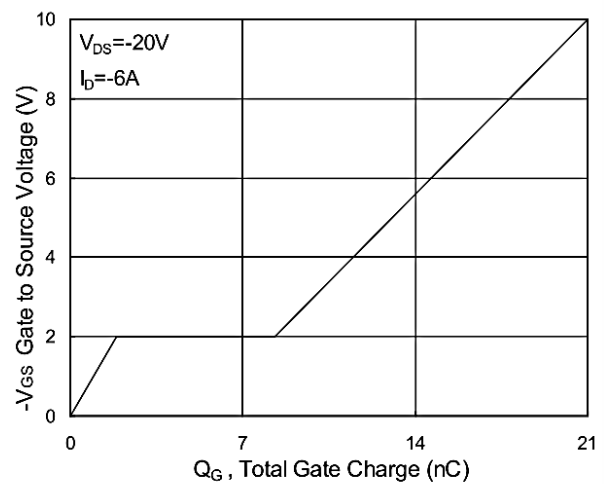

Fig.4 Gate-Charge Characteristics

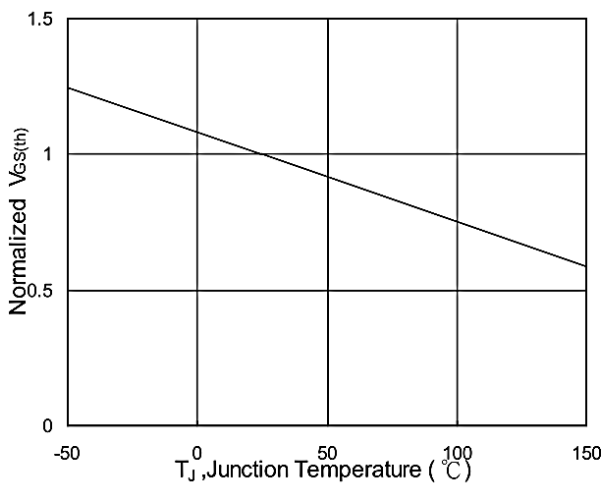

Fig.5 Normalized $V_{GS(th)}$ v.s T_J

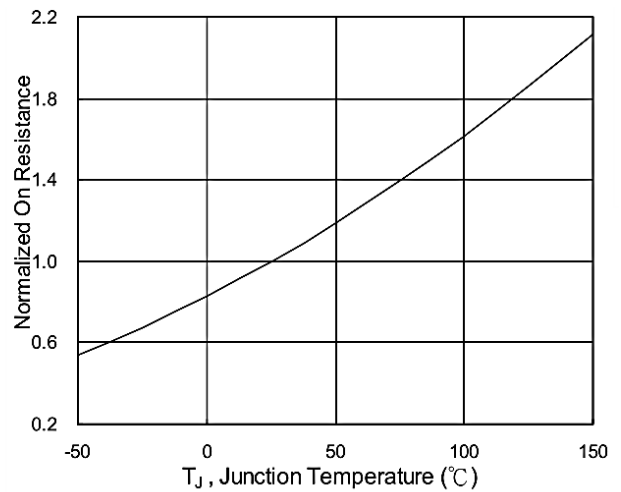

Fig.6 Normalized $R_{DS(on)}$ v.s T_J

Ratings and Characteristic Curves

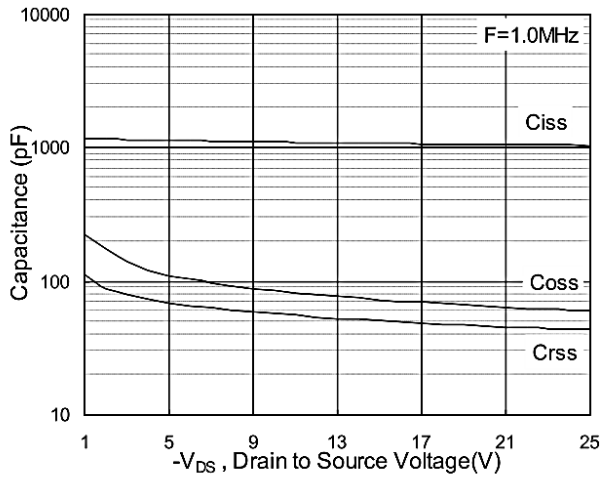

Fig.7 Capacitance

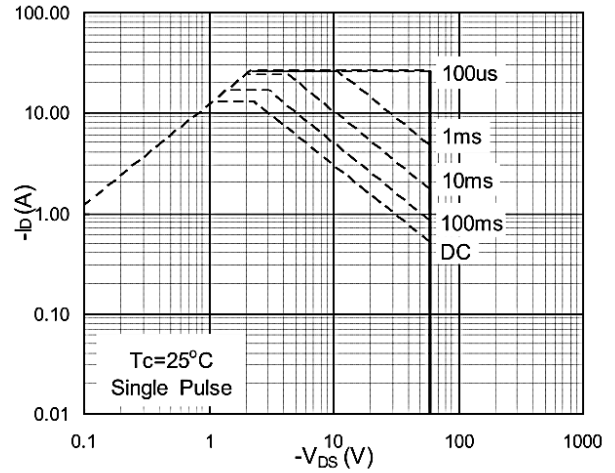

Fig.8 Safe Operating Area

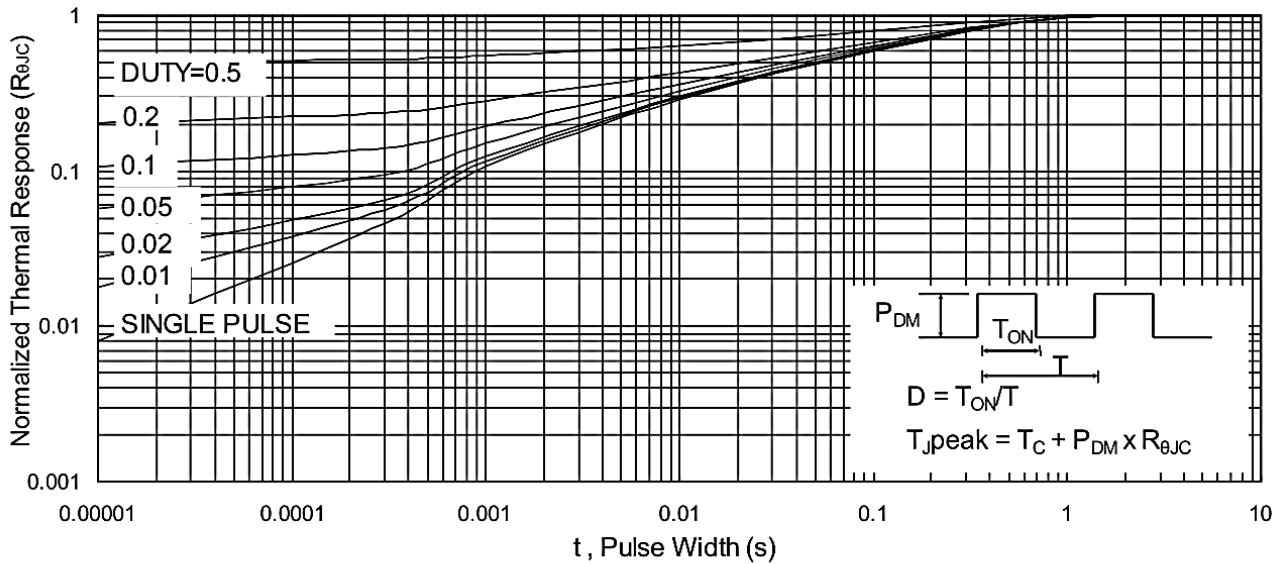

Fig.9 Normalized Maximum Transient Thermal Impedance

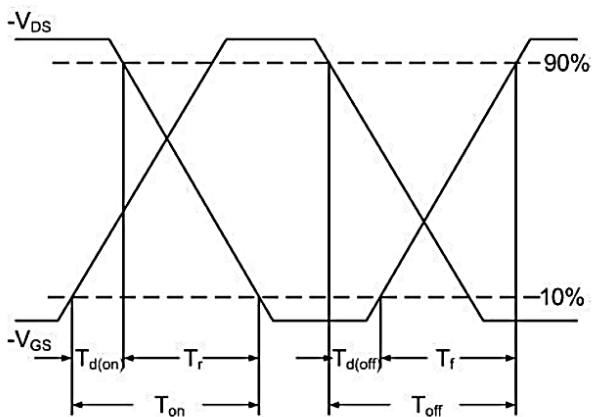

Fig.10 Switching Time Waveform

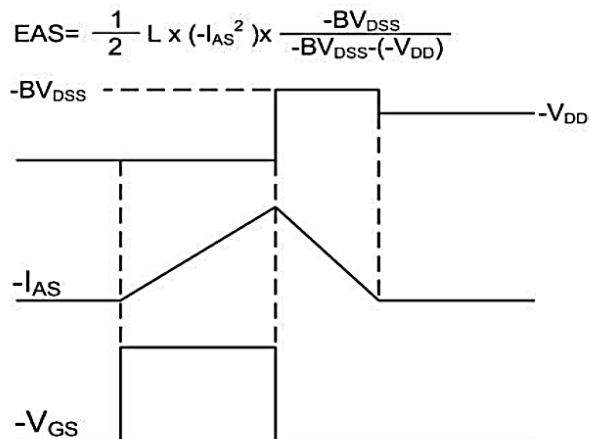
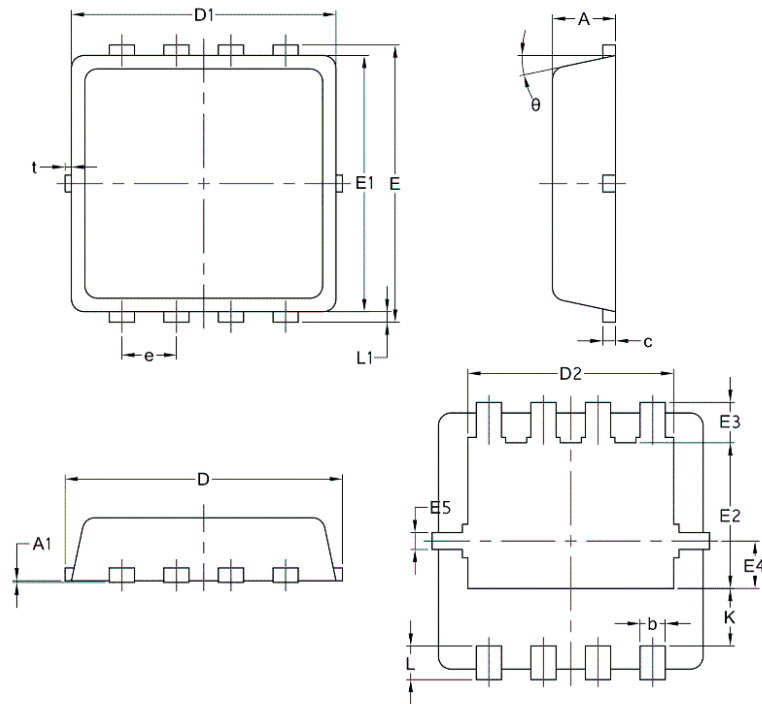

Fig.11 Unclamped Inductive Switching Waveform

PDFN3*3-8L



Symbol	Common		
	mm		
	Mim	Nom	Max
A	0.70	0.75	0.85
A1	/	/	0.05
b	0.20	0.30	0.40
c	0.10	0.152	0.25
D	3.15	3.30	3.45
D1	3.00	3.15	3.25
D2	2.29	2.45	2.65
E	3.15	3.30	3.45
E1	2.90	3.05	3.20
E2	1.54	1.74	1.94
E3	0.28	0.48	0.65
E4	0.37	0.57	0.77
E5	0.10	0.20	0.30
e	0.60	0.65	0.70
K	0.59	0.69	0.89
L	0.30	0.40	0.50
L1	0.06	0.125	0.20
t	0	0.075	0.13
Φ	10	12	14