

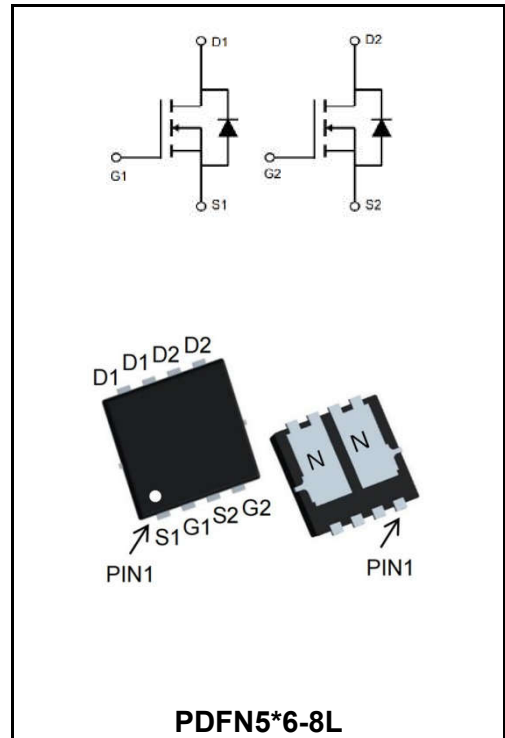
**40V N+N-CHANNEL ENHANCEMENT MODE MOSFET**

**MAIN CHARACTERISTICS**

<b>I<sub>D</sub></b>	40A
<b>V<sub>DSS</sub></b>	40V
<b>R<sub>DS(on)-typ(@V<sub>GS</sub>=10V)</sub></b>	< 9mΩ ( <b>Type:6.9 mΩ</b> )

**Application**

- ◆ Battery protection
- ◆ Load switch
- ◆ Uninterruptible power supply



**Product Specification Classification**

Part Number	Package	Marking	Pack
YFW40H04NF	PDFN5*6-8L	YFW 40H04NF XXXXX	5000PCS/Tape

**Maximum Ratings at T<sub>c</sub>=25°C unless otherwise specified**

Characteristics	Symbols	Value	Units
Drain-Source Voltage	<b>V<sub>DS</sub></b>	40	<b>V</b>
Gate - Source Voltage	<b>V<sub>GS</sub></b>	±20	<b>V</b>
Continuous Drain Current, V <sub>GS</sub> @ 10V <sup>1</sup> @T <sub>c</sub> =25°C	<b>I<sub>D</sub></b>	40	<b>A</b>
Continuous Drain Current, V <sub>GS</sub> @ 10V <sup>1</sup> @T <sub>c</sub> =75°C	<b>I<sub>D</sub></b>	20	<b>A</b>
Pulsed Drain Current <sup>2</sup>	<b>I<sub>DM</sub></b>	120	<b>A</b>
Single Pulse Avalanche Energy <sup>3</sup>	<b>E<sub>AS</sub></b>	48	<b>mJ</b>
Avalanche Current	<b>I<sub>AS</sub></b>	31	<b>A</b>
Total Power Dissipation <sup>4</sup> @T <sub>c</sub> =25°C	<b>P<sub>D</sub></b>	33.7	<b>W</b>
Total Power Dissipation <sup>4</sup> @T <sub>A</sub> =25°C	<b>P<sub>D</sub></b>	2	<b>W</b>
Storage Temperature Range	<b>T<sub>STG</sub></b>	-55 to +150	<b>°C</b>
Operating Junction Temperature Range	<b>T<sub>J</sub></b>	-55 to +150	<b>°C</b>
Thermal Resistance Junction-ambient <sup>1</sup>	<b>R<sub>θJA</sub></b>	25	<b>°C/W</b>
Thermal Resistance Junction-Case <sup>1</sup>	<b>R<sub>θJC</sub></b>	3.2	<b>°C/W</b>

**Maximum Ratings at Tc=25°C unless otherwise specified**

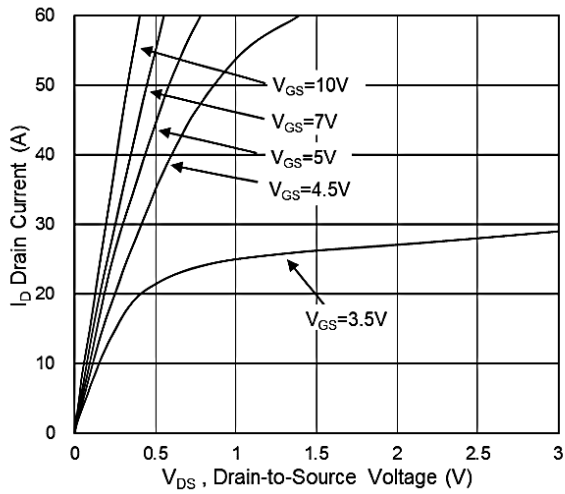
Characteristics	Test Condition	Symbols	Min	Typ	Max	Units
Drain-Source Breakdown Voltage	$V_{GS}=0V, I_D=250\mu A$	$B_{VDSS}$	40	44	-	<b>V</b>
Static Drain-Source On-Resistance <sup>2</sup>	$V_{GS}=10V, I_D=12A$	$R_{DS(ON)}$	-	6.9	9.0	<b>mΩ</b>
	$V_{GS}=4.5V, I_D=10A$		-	10.5	15	
Gate Threshold Voltage	$V_{DS}=V_{GS}, I_D=250\mu A$	$V_{GS(th)}$	1.2	1.6	2.5	<b>V</b>
Drain-Source Leakage Current	$V_{DS}=32V, V_{GS}=0V, T_J=25^\circ C$	$I_{DSS}$	-	-	1	<b>uA</b>
	$V_{DS}=32V, V_{GS}=0V, T_J=55^\circ C$		-	-	5	
Gate-Source Leakage Current	$V_{GS}=\pm 20V, V_{DS}=0V$	$I_{GSS}$	-	-	$\pm 100$	<b>nA</b>
Gate Resistance	$V_{DS}=0V, V_{GS}=0V, f=1MHz$	$R_g$		1.7		<b>Ω</b>
Total Gate Charge ( 4.5V )	$V_{DS}=20V$ $V_{GS}=4.5V$ $I_D=12A$	$Q_g$	-	5.8	-	<b>nC</b>
Gate-Source Charge		$Q_{GS}$	-	3	-	
Gate-Drain Charge		$Q_{gd}$	-	1.2	-	
Turn-on delay time	$V_{DD}=15V$ $V_{GS}=10V$ $R_G=3.3\Omega$ $I_D=1A$	$t_{d(on)}$	-	14.3	-	<b>ns</b>
Rise Time		$T_r$	-	5.6	-	
Turn-Off Delay Time		$t_{d(OFF)}$	-	20	-	
Fall Time		$t_f$	-	11	-	
Input Capacitance	$V_{DS}=15V$ $V_{GS}=0V$ $f=1.0MHz$	$C_{iss}$	-	690	-	<b>μF</b>
Output Capacitance		$C_{oss}$	-	193	-	
Reverse Transfer Capacitance		$C_{rss}$	-	38	-	
Continuous Source Current <sup>1,5</sup>	$V_G=V_D=0V$ , Force Current	$I_S$	-	-	30	<b>A</b>
Diode Forward Voltage <sup>2</sup>	$V_{GS}=0V, I_S=1A, T_J=25^\circ C$	$V_{SD}$	-	-	1	<b>V</b>

Note :

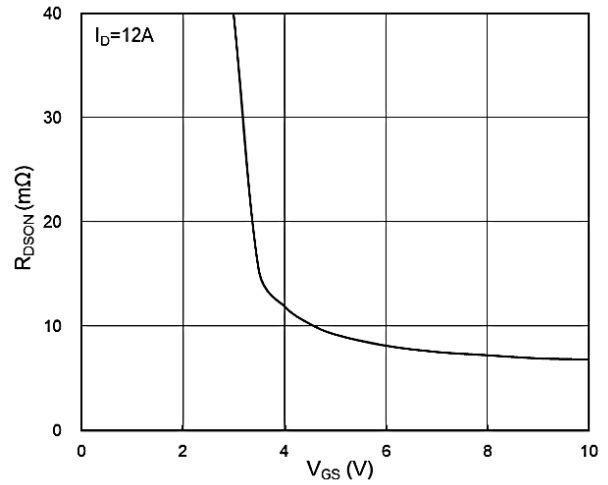
- 1、 The data tested by surface mounted on a 1 inch 2 FR-4 board with 20Z copper.
- 2、 The data tested by pulsed , pulse width  $\leq 300\mu s$  , duty cycle  $\leq 2\%$
- 3、 The EAS data shows Max. rating . The test condition is  $V_{DD}=25V, V_{GS}=10V, L=0.1mH, I_{AS}=31A$
- 4、 The power dissipation is limited by 150°C junction temperature
- 5、 The data is theoretically the same as ID and IDM , in real applications , should be limited by total power dissipation.

**Ratings and Characteristic Curves**

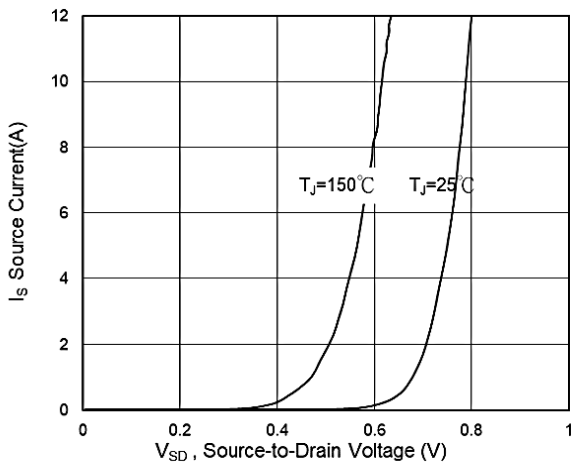
**Typical Characteristics**



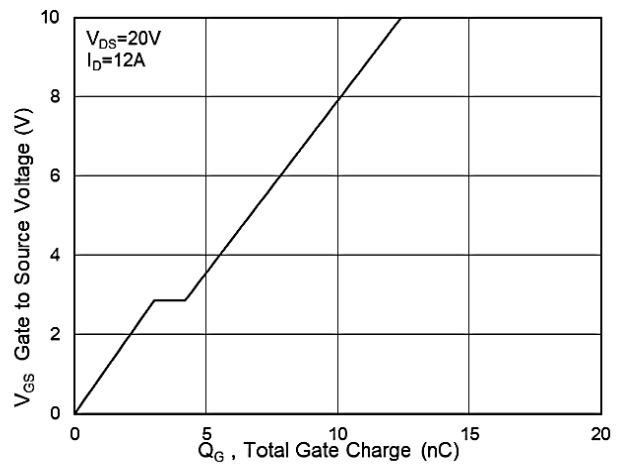
**Fig.1 Typical Output Characteristics**



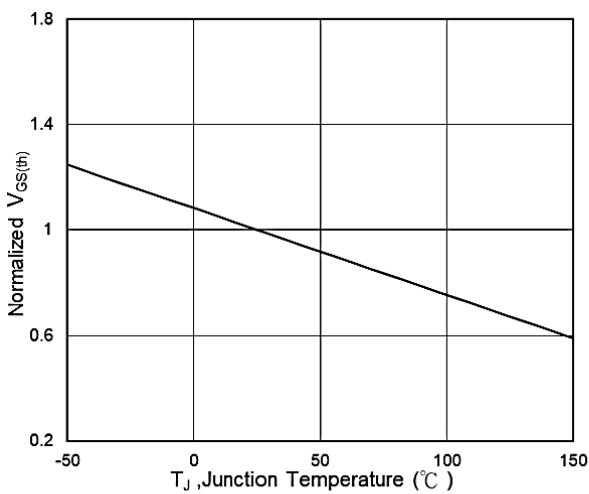
**Fig.2 On-Resistance vs G-S Voltage**



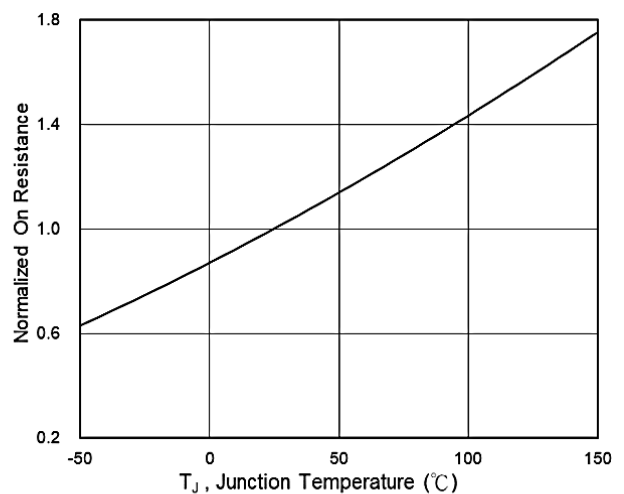
**Fig.3 Source Drain Forward Characteristics**



**Fig.4 Gate-Charge Characteristics**

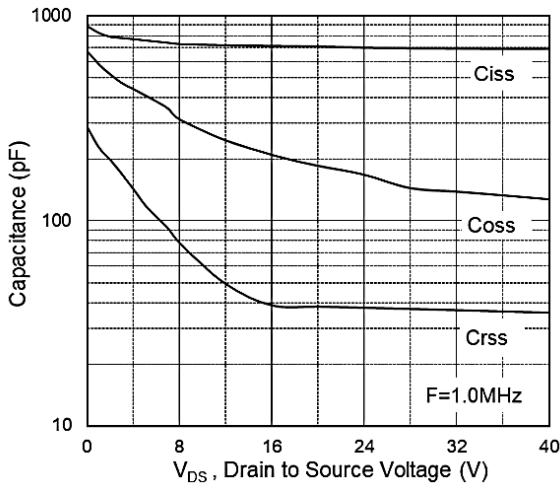


**Fig.5 Normalized  $V_{GS(th)}$  vs  $T_J$**

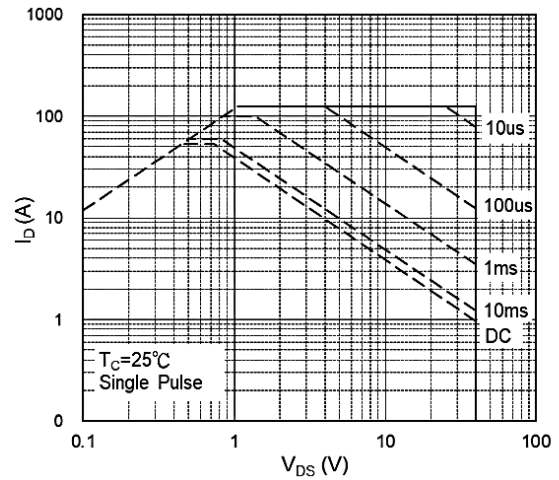


**Fig.6 Normalized  $R_{DS(on)}$  vs  $T_J$**

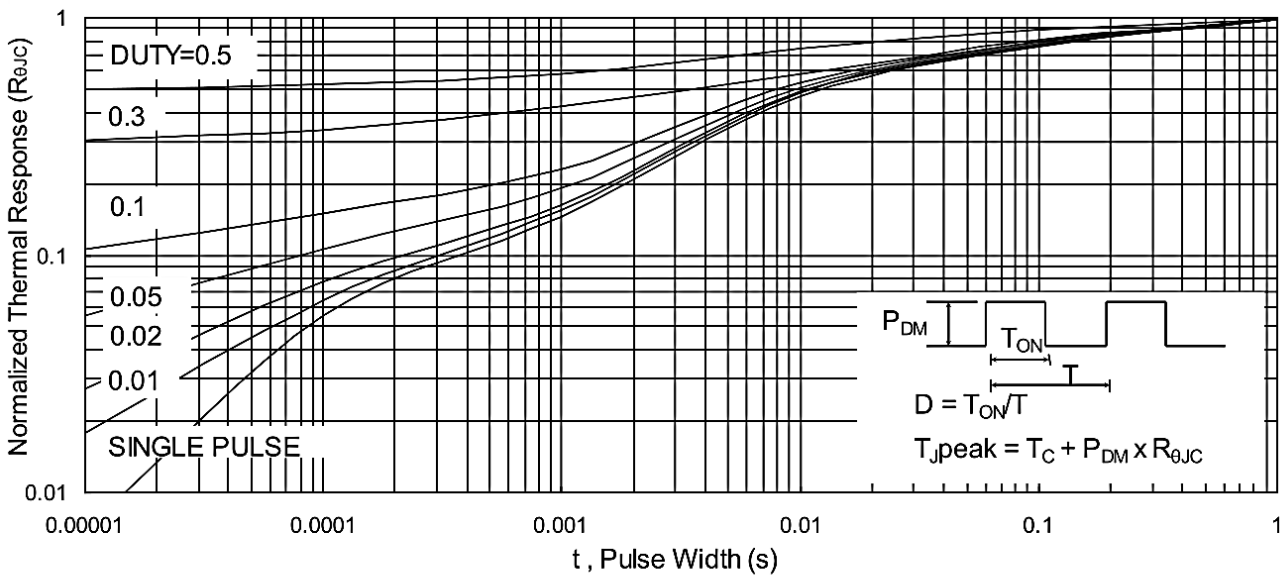
**Ratings and Characteristic Curves**



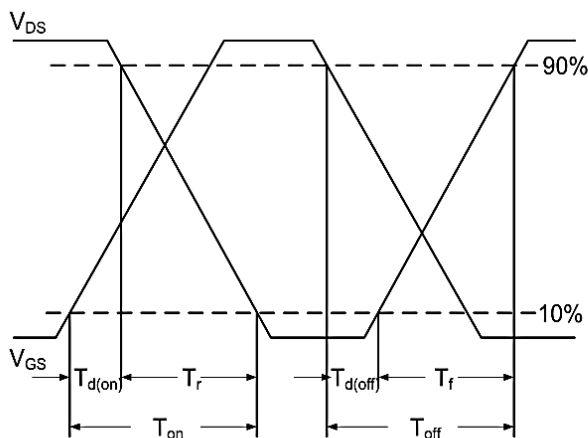
**Fig.7 Capacitance**



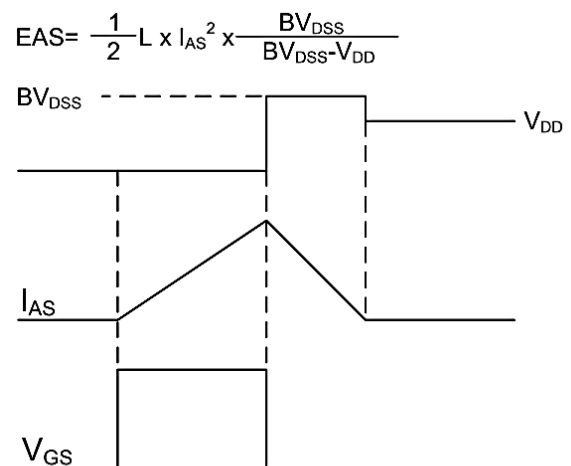
**Fig.8 Safe Operating Area**



**Fig.9 Normalized Maximum Transient Thermal Impedance**

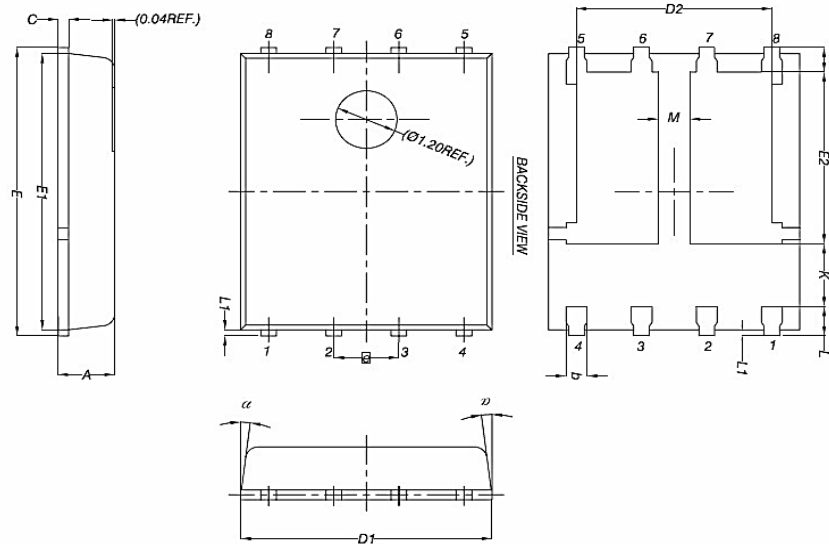


**Fig.10 Switching Time Waveform**



**Fig.11 Unclamped Inductive Waveform**

**PDFN5\*6-8L**



Symbol	Common		
	mm		
	Mim	Nom	Max
A	0.90	1.00	1.10
b	0.33	0.41	0.51
C	0.20	0.25	0.30
D1	4.80	4.90	5.00
D2	3.61	3.81	3.96
E	5.90	6.00	6.10
E1	5.70	3.30	3.45
E2	3.38	3.05	3.20
e	1.27BSC		
H	0.41	0.51	0.61
K	1.10	--	--
L	0.51	0.61	0.71
L1	0.06	0.13	0.20
M	0.50	--	--
a	0°	--	12°