

60V N-CHANNEL ENHANCEMENT MODE MOSFET

MAIN CHARACTERISTICS

I_D	50A
V_{DSS}	60V
$R_{DS(on)-typ}(@V_{GS}=10V)$	< 20mΩ (Type: 13.5 mΩ)

Application

- ◆ Battery protection
- ◆ Load switch
- ◆ Uninterruptible power supply

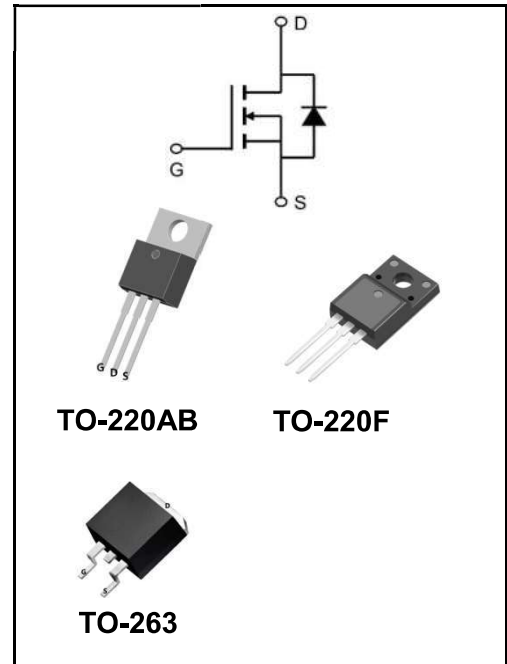

Product Specification Classification

Part Number	Package	Marking	Pack
YFW50N06AT	TO-220AB	YFW 50N06AT XXXXX	1000PCS/Box
YFW50N06AF	TO-220F	YFW 50N06AF XXXXX	1000PCS/Box
YFW50N06AS	TO-263	YFW 50N06AS XXXXX	800PCS/Reel

Maximum Ratings at Tc=25°C unless otherwise specified

Characteristics	Symbols	Value	Units
Drain-Source Voltage	V_{DS}	60	V
Gate - Source Voltage	V_{GS}	±20	V
Continuous Drain Current, $V_{GS} @ 10V^1 @ T_C=25^\circ C$	I_D	50	A
Continuous Drain Current, $V_{GS} @ 10V^1 @ T_C=100^\circ C$	I_D	34	A
Pulsed Drain Current ²	I_{DM}	100	A
Single Pulse Avalanche Energy ³	E_{AS}	40	mJ
Avalanche Current	I_{AS}	28	A
Total Power Dissipation ⁴ @ $T_C=25^\circ C$	P_D	74	W
Storage Temperature Range	T_{STG}	-55 to +150	°C
Operating Junction Temperature Range	T_J	-55 to +150	°C
Thermal Resistance, Junction-to-Ambient ¹	$R_{\theta JA}$	62	°C/W
Thermal Resistance Junction-Case ¹	$R_{\theta JC}$	1.68	°C/W

Maximum Ratings at Tc=25°C unless otherwise specified

Characteristics	Test Condition	Symbols	Min	Typ	Max	Units
Drain-Source Breakdown Voltage	$V_{GS}=0V, I_D=250\mu A$	BV_{DSS}	60	-	-	V
Static Drain-Source On-Resistance ²	$V_{GS}=10V, I_D=20A$	$R_{DS(ON)}$	-	13.5	20	mΩ
Gate -Threshold Voltage	$V_{DS}=V_{GS}, I_D=250\mu A$	$V_{GS(th)}$	1.2	-	2.5	V
Drain -Source Leakage Current	$V_{DS}=48V, V_{GS}=0V, T_J=25^\circ C$	I_{DSS}	-	-	1	μA
	$V_{DS}=48V, V_{GS}=0V, T_J=55^\circ C$		-	-	5	
Gate-Source Leakage Current	$V_{GS}=\pm 20V, V_{DS}=0V$	I_{GSS}	-	-	±100	nA
Forward Transconductance	$V_{DS}=5V, I_D=20A$	g_{FS}	-	25	-	S
Total Gate Charge(4.5V)	$V_{DS}=48V$ $V_{GS}=4.5V$ $I_D=15A$	Q_g	-	29.3	-	nC
Gate-Source Charge		Q_{GS}	-	7.1	-	
Gate-Drain Charge		Q_{GD}	-	7.6	-	
Turn-on delay time	$V_{DD}=30V$ $V_{GS}=10V$ $R_G=3.3$ $I_D=15A$	$t_{d(on)}$	-	7.2	-	ns
Rise Time		T_r	-	50	-	
Turn-Off Delay Time		$t_{d(OFF)}$	-	36.4	-	
Fall Time		t_f	-	7.6	-	
Input Capacitance	$V_{DS}=15V$ $V_{GS}=0V$ $f=1.0MHz$	C_{iss}	-	2423	-	pF
Output Capacitance		C_{oss}	-	145	-	
Reverse Transfer Capacitance		C_{rss}	-	97	-	
Continuous Source Current ^{1,5}	$V_G=V_D=0V$, Force Current	I_S	-	-	45	A
Diode Forward Voltage ²	$V_{GS}=0V, I_S=1A, T_J=25^\circ C$	V_{SD}	-	-	1	V
Reverse Recovery Time	$I_F=15A, dI/dt=100A/\mu s,$ $T_J=25^\circ C$	t_{rr}	-	16.3	-	nS
Reverse Recovery Charge		Q_{rr}	-	11	-	nC

Note :

- 1.The data tested by surface mounted on a 1 inch² FR-4 board with 2OZ copper.
- 2.The data tested by pulsed , pulse width $\cong 300\mu s$, duty cycle $\cong 2\%$
- 3.The EAS data shows Max. rating . The test condition is $V_{DD}=25V, V_{GS}=10V, L=0.1mH, I_{AS}=28A$
- 4.The power dissipation is limited by 150°C junction temperature
- 5.The data is theoretically the same as ID and IDM , in real applications , should be limited by total power dissipation.

Ratings and Characteristic Curves

Typical Characteristics

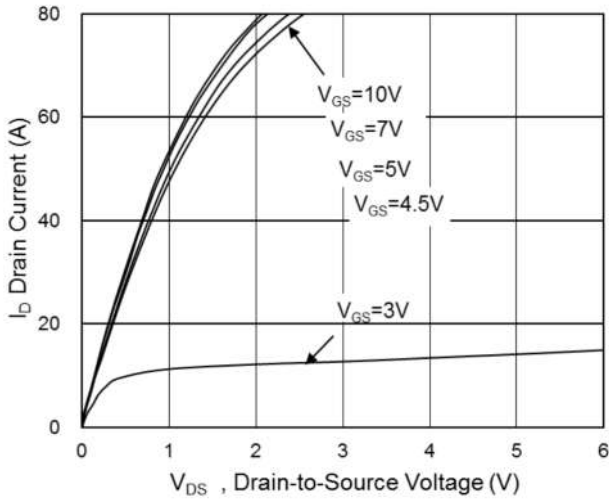

Fig.1 Typical Output Characteristics

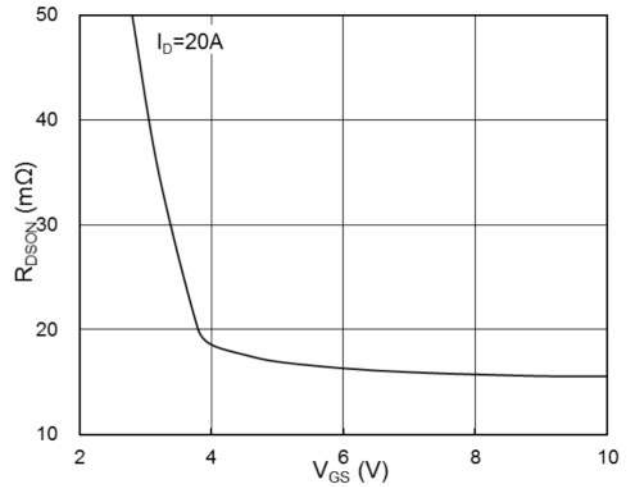

Fig.2 On-Resistance vs Gate-Source Voltage

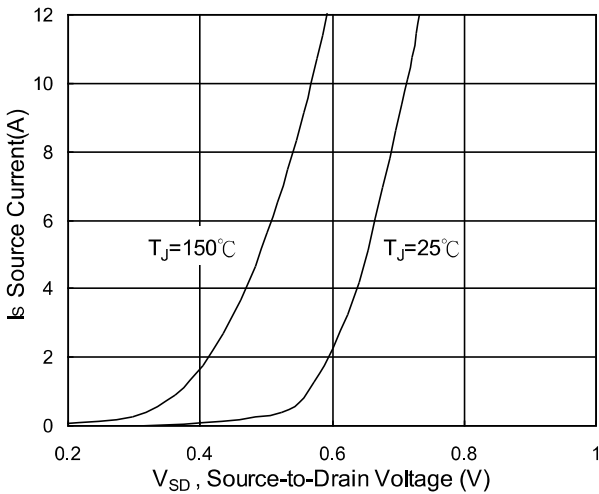

Fig.3 Forward Characteristics of Reverse

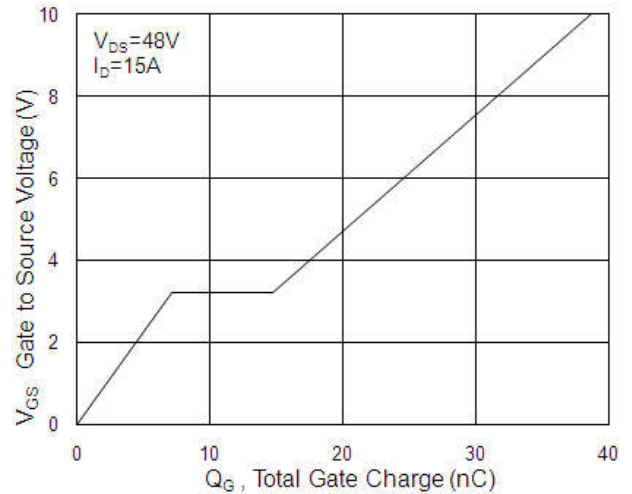

Fig.4 Gate-Charge Characteristics

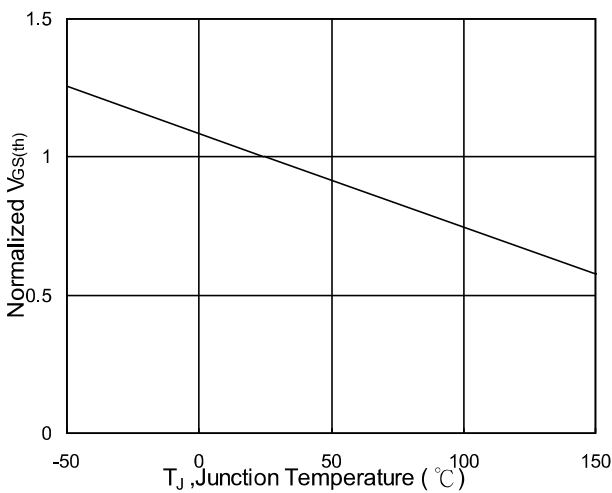

Fig.5 Normalized $V_{GS(th)}$ vs T_J

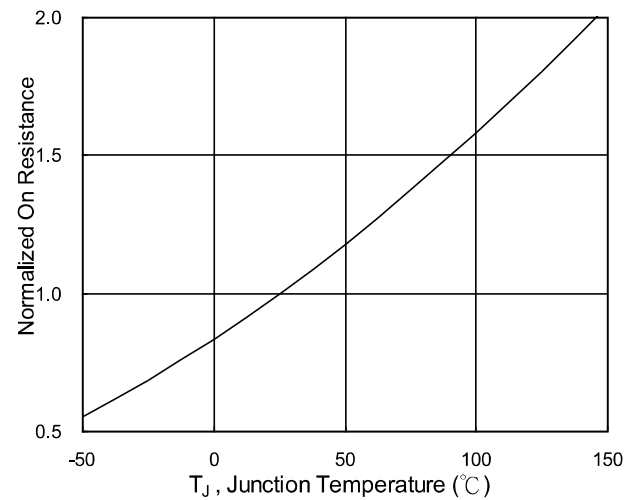

Fig.6 Normalized $R_{DS(on)}$ vs T_J

Ratings and Characteristic Curves

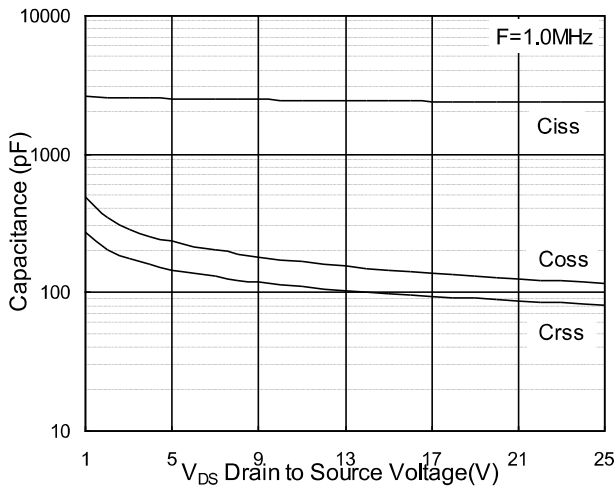

Fig.7 Capacitance

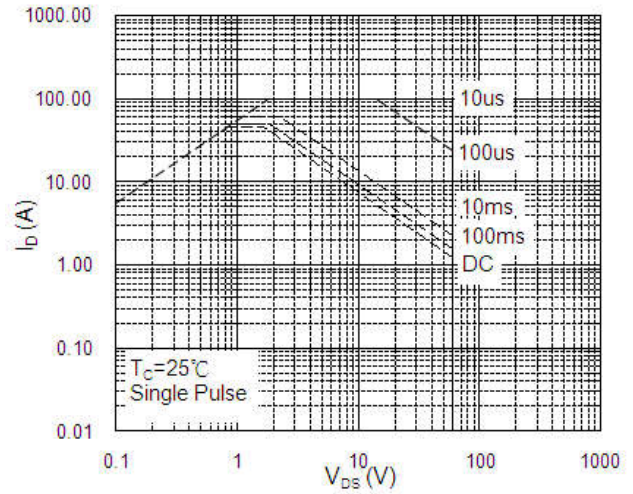

Fig.8 Safe Operating Area

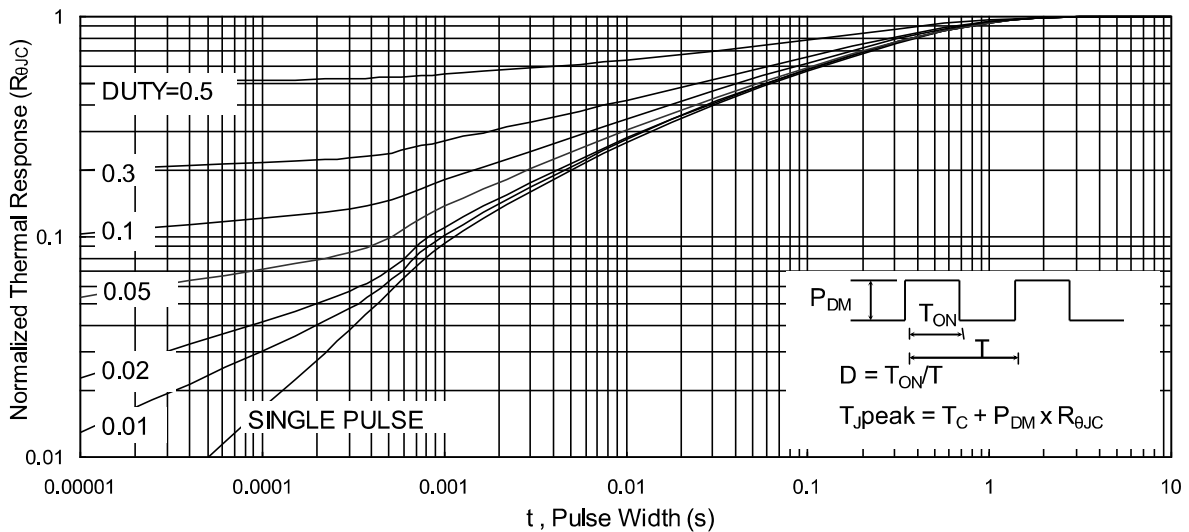

Fig.9 Normalized Maximum Transient Thermal Impedance

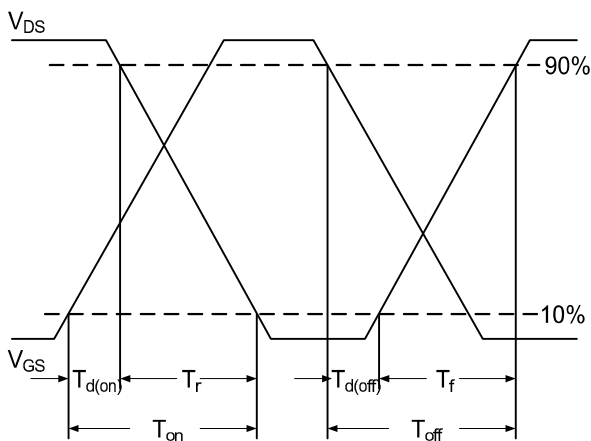

Fig.10 Switching Time Waveform

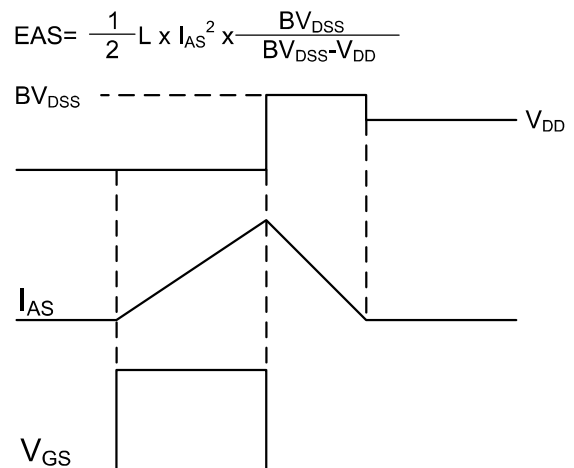

Fig.11 Unclamped Inductive Switching Waveform

Package Outline Dimensions Millimeters

TO-220AB

Dim.	Min.	Max.
A	10.15	10.35
B	2.65	2.95
C	3.70	3.90
D	28.5	29.5
E	1.30	1.45
F	6.35	6.55
G	2.9	3.3
H	15.0	16.0
I	0.38	0.42
J	4.45	4.55
K	1.25	1.35
L	Typ 5.08	
M	Typ 2.54	
N	3.1	3.3
O	0.76	0.84
All Dimensions in millimeter		

TO-220F

Dim.	Min.	Max.
A	9.95	10.25
B	2.95	3.25
C	1.25	1.45
D	12.95	13.25
E	0.50	0.65
F	3.1	3.3
G	1.30	1.45
H	Typ 2.54	
I	Typ 5.08	
J	4.60	4.75
K	2.50	2.65
L	6.35	6.55
M	15.4	16.0
N	2.75	3.05
O	0.48	0.52
P	0.76	0.84
All Dimensions in millimeter		

Package Outline Dimensions Millimeters

TO-263

	Dim.	Min.	Max.
	A	10.1	10.2
	B	7.4	7.6
	C	1.3	1.5
	D	0.55	0.75
	E	5.0	6.0
	F	1.4	1.6
	G	0.78	0.86
	H	1.2	1.3
	I	Typ2.54	
	J	8.4	8.6
	K	4.45	4.55
	L	1.25	1.35
	M	0.02	0.1
	N	2.4	2.8
O	0.36	0.40	
All Dimensions in millimeter			