

Plastic-Encapsulate MOSFETs

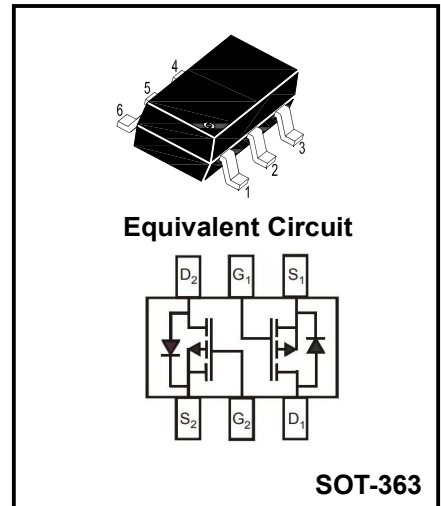

P-CHANNEL MOSFET

$V_{(BR)DSS}$	$R_{DS(on)MAX}$	I_D
-50 V	8Ω@-10V	-0.13A
	10Ω@ -5V	

DESCRIPTION

These miniature surface mount MOSFETs reduce power loss conserve energy, making this device ideal for use in small power management circuitry.

FEATURE

- ◆Energy Efficient
- ◆Low Threshold Voltage
- ◆High-speed Switching
- ◆Miniature Surface Mount Package Saves Board Space

APPLICATION

DC-DC converters, load switching, power management in portable and battery-powered products such as computers, printers, cellular and cordless telephones.

MARKING

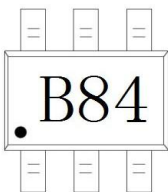

MAXIMUM RATINGS (Ta=25°C unless otherwise noted)

Parameter	Symbol	Value	Unit
Drain-Source Voltage	V_{DS}	-50	V
Gate-Source Voltage	V_{GS}	±20	V
Continuous Drain Current	I_D	-0.13	A
Pulsed Drain Current (note 1) @tp <10 μs	I_{DM}	-0.52	A
Power Dissipation	P_D	225	mW
Thermal Resistance from Junction to Ambient (note 2)	$R_{θJA}$	556	°C/W
Junction Temperature	T_J	150	°C
Storage Temperature	T_{STG}	-55~+150	°C
Maximum Lead Temperature for Soldering Purposes , Duration for 5 Seconds	T_L	260	°C

Ta=25°C unless otherwise specified

Parameter	Symbol	Test Condition	Min	Typ	Max	Unit
STATIC CHARACTERISTICS						
Drain-source breakdown voltage	$V_{(BR)DSS}$	$V_{GS} = 0V, I_D = -250\mu A$	-50			V
Zero gate voltage drain current	I_{DSS}	$V_{DS} = -50V, V_{GS} = 0V$			-15	μA
		$V_{DS} = -25V, V_{GS} = 0V$			-0.1	μA
Gate-body leakage current	I_{GSS}	$V_{GS} = \pm 20V, V_{DS} = 0V$			± 5	μA
Gate threshold voltage (note 3)	$V_{GS(th)}$	$V_{DS} = V_{GS}, I_D = -250\mu A$	-0.9	-1.6	-2	V
Drain-source on-resistance (note 3)	$R_{DS(on)}$	$V_{GS} = -5V, I_D = -0.1A$		5.8	10	Ω
		$V_{GS} = -10V, I_D = -0.1A$		4.5	8	Ω
Forward transconductance (note 1)	g_{FS}	$V_{DS} = -25V; I_D = -100mA$	50			mS
DYNAMIC CHARACTERISTICS (note 4)						
Input capacitance	C_{iss}	$V_{DS} = 5V, V_{GS} = 0V, f = 1MHz$		30		pF
Output capacitance	C_{oss}			10		pF
Reverse transfer capacitance	C_{rss}			5		pF
SWITCHING CHARACTERISTICS (note 4)						
Turn-on delay time	$t_{d(on)}$	$V_{DD} = -15V,$ $R_L = 50\Omega, I_D = -2.5A$		2.5		ns
Turn-on rise time	t_r			1		ns
Turn-off delay time	$t_{d(off)}$			16		ns
Turn-off fall time	t_f			8		ns
SOURCE-DRAIN DIODE CHARACTERISTICS						
Continuous Current	I_S				-0.13	A
Pulsed Current	I_{SM}				-0.52	A
Diode forward voltage (note 3)	V_{SD}	$I_S = -0.13A, V_{GS} = 0V$			-2.2	V

Notes :

1. Repetitive rating : Pulse width limited by junction temperature.
2. Surface mounted on FR4 board , $t \leq 10s$.
3. Pulse Test : Pulse Width $\leq 300\mu s$, Duty Cycle $\leq 2\%$.
4. Guaranteed by design, not subject to producing.

Typical Characteristics

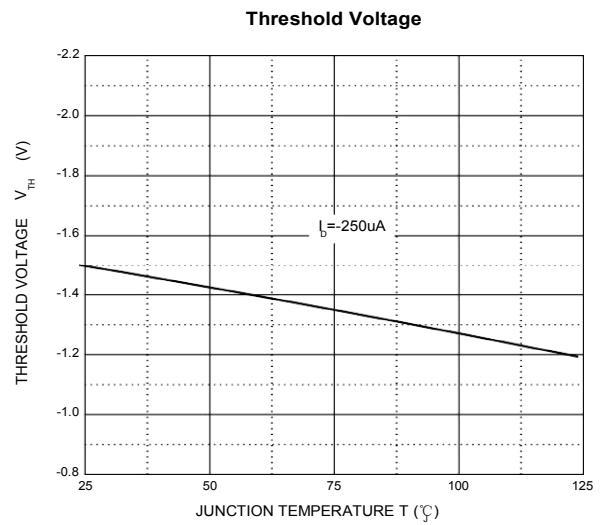
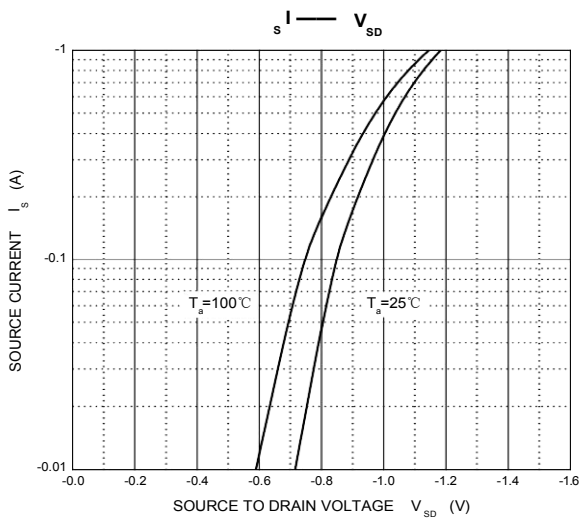
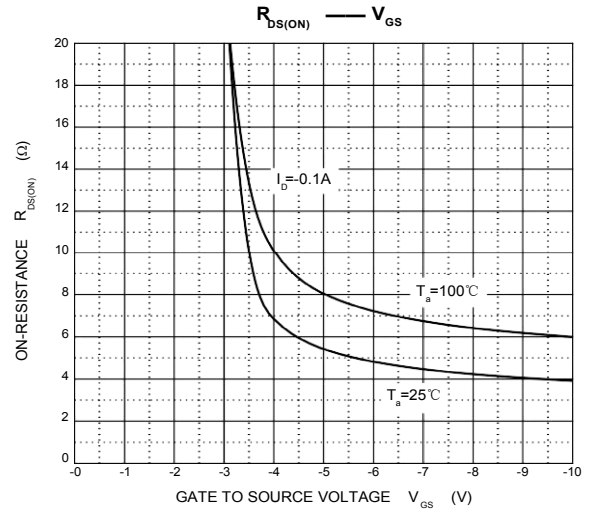
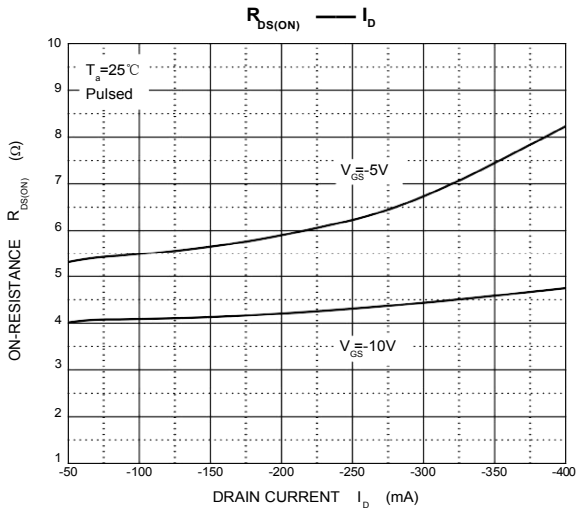
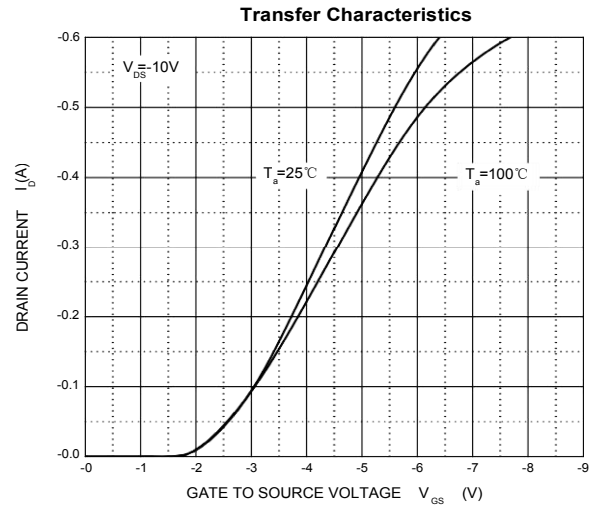
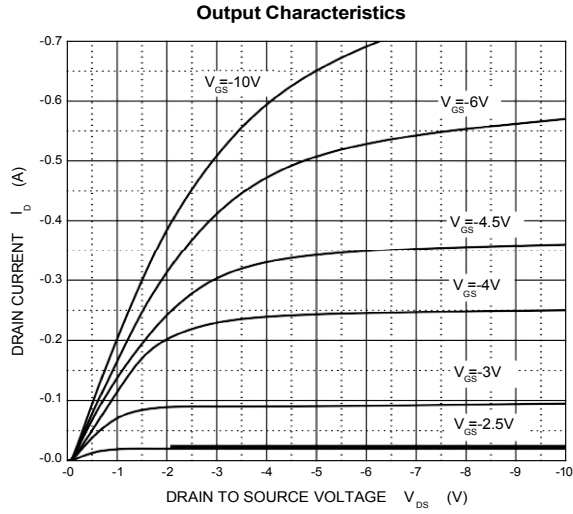

Package Outline SOT-363

Plastic surface mounted package; 3 leads

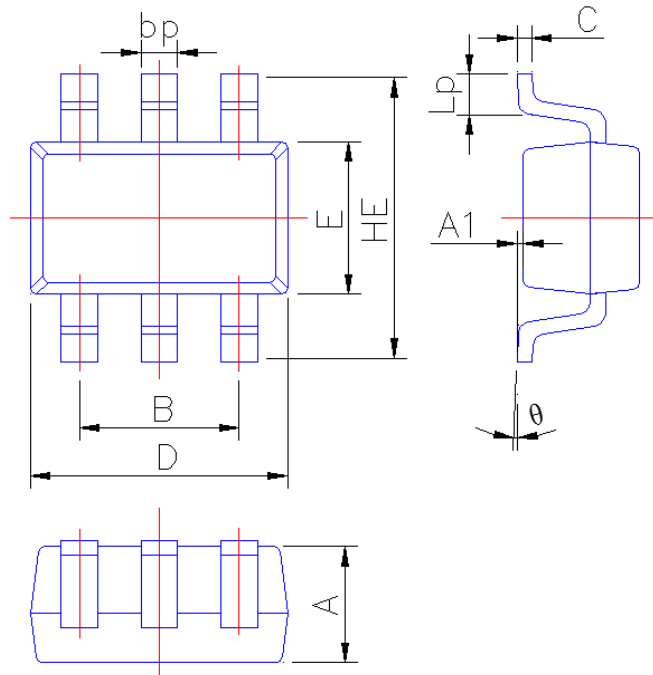

Symbol	Dimension in Millimeters	
	Min	Max
A	0.90	1.00
A1	0.010	0.100
B	1.20	1.40
bp	0.25	0.45
C	0.09	0.15
D	2.00	2.20
E	1.15	1.35
HE	2.15	2.55
Lp	0.25	0.46
θ	0°	6°

Summary of Packing Options

Package	Package Description	Packing Quantity	Industry Standard
SOT-363	Tape/Reel, 7" reel	3000	EIA-481-1