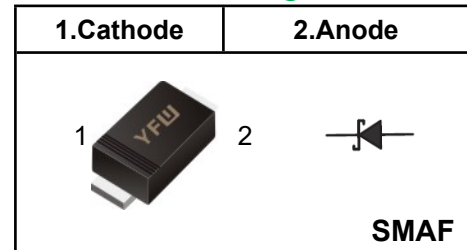


**Surface Mount Schottky Barrier Rectifier**
**Reverse Voltage - 45V**
**Forward Current - 3 A**
**FEATURES**

- ◆Metal silicon junction, majority carrier conduction
- ◆For surface mounted applications
- ◆Low power loss, high efficiency
- ◆High forward surge current capability
- ◆For use in low voltage, high frequency inverters, free wheeling, and polarity protection applications
- ◆Lead free in comply with EU RoHS 2011/65/EU directives

**MECHANICAL DATA**

- ◆Case: SMAF
- ◆Terminals: Solderable per MIL-STD-750, Method 2026
- ◆Approx. Weight: 27mg / 0.00095oz

**Pinning**

**Marking Code**

<b>SSL345F</b>	<b>SL345</b>
----------------	--------------

**Absolute Maximum Ratings and Electrical characteristics**

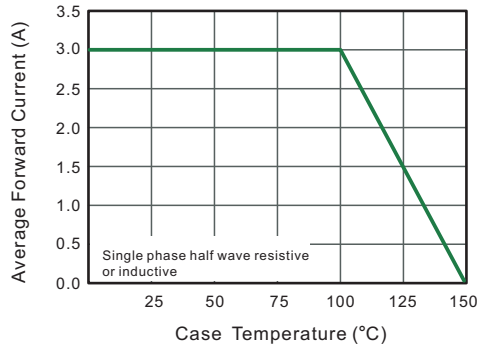
Ratings at 25 ° ambient temperature unless otherwise specified.Single phase, half wave, 60Hz resistive or inductive load, for capacitive load, derate by 20 %

Parameter	Symbols	SSL345F	Units
Maximum Repetitive Peak Reverse Voltage	$V_{RRM}$	45	<b>V</b>
Maximum RMS voltage	$V_{RMS}$	32	<b>V</b>
Maximum DC Blocking Voltage	$V_{DC}$	45	<b>V</b>
Maximum Average Forward Rectified Current	$I_{F(AV)}$	3.0	<b>A</b>
Peak Forward Surge Current, 8.3ms Single Half Sine-wave Superimposed On Rated Load (JEDEC method)	$I_{FSM}$	80	<b>A</b>
Maximum Instantaneous Forward Voltage at 3 A	$V_F$	0.45	<b>V</b>
Maximum Instantaneous Reverse Current at Rated DC Reverse Voltage <small><math>T_A = 25^{\circ}C</math> <math>T_A = 100^{\circ}C</math></small>	$I_R$	0.3 5	<b>mA</b>
Typical Junction Capacitance <sup>(1)</sup>	$C_j$	300	<b>pF</b>
Typical Thermal Resistance <sup>(2)</sup>	$R_{\theta JA}$	60	<b>°C/W</b>
Operating Junction Temperature Range	$T_j$	-55 ~ +150	<b>°C</b>
Storage Temperature Range	$T_{stg}$	-55 ~ +150	<b>°C</b>

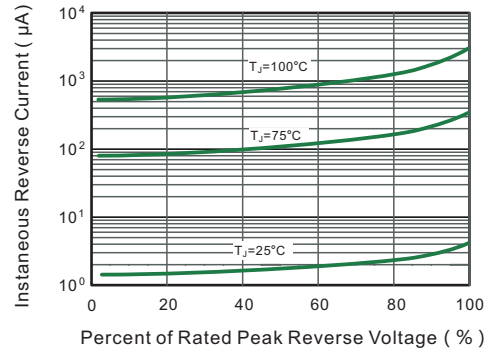
(1) Measured at 1 MHz and applied reverse voltage of 4 V D.C

(2) P.C.B. mounted with 2.0" X 2.0" (5 X 5 cm) copper pad areas.

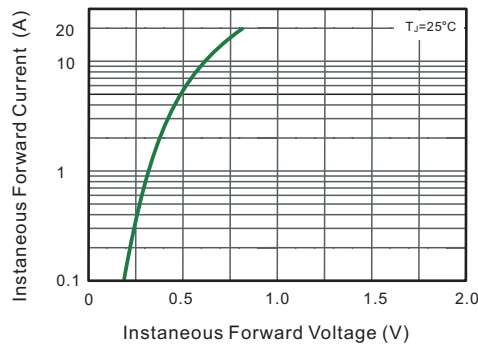
**Fig.1 Forward Current Derating Curve**



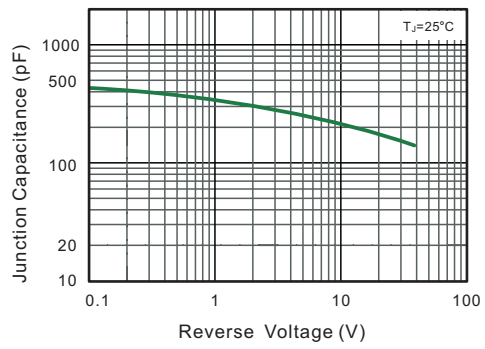
**Fig.2 Typical Reverse Characteristics**



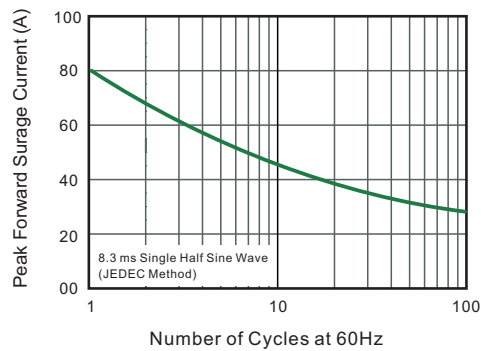
**Fig.3 Typical Forward Characteristic**



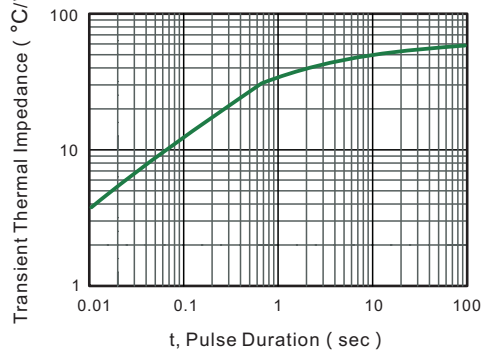
**Fig.4 Typical Junction Capacitance**



**Fig.5 Maximum Non-Repetitive Peak Forward Surge Current**

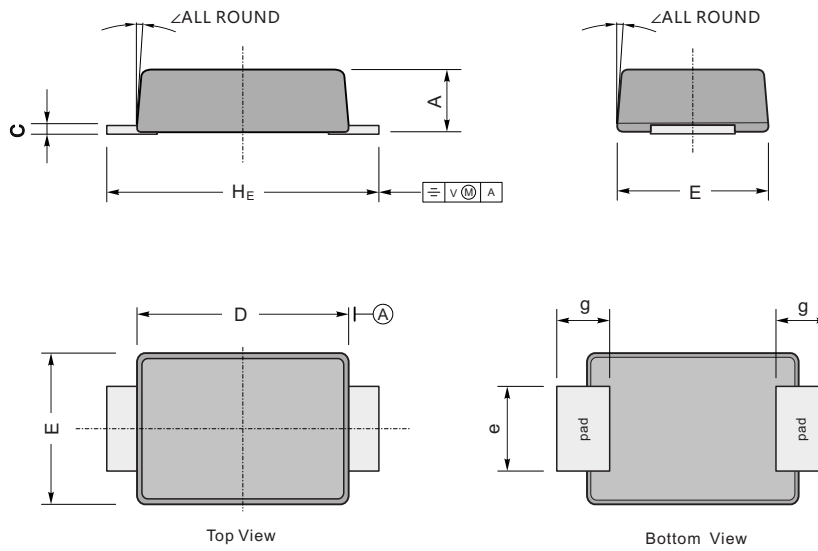


**Fig.5- Typical Transient Thermal Impedance**



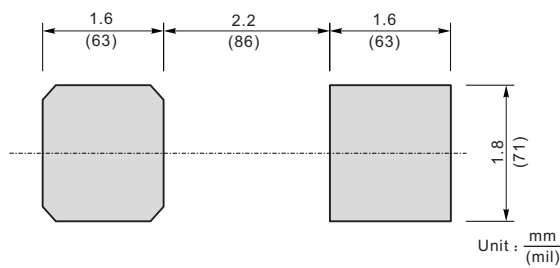
**Package Outline SMAF**

Plastic surface mounted package; 2 leads



UNIT		A	C	D	E	e	g	H <sub>E</sub>	$\sphericalangle$
mm	max	1.1	0.20	3.7	2.7	1.6	1.2	4.9	7°
	min	0.9	0.12	3.3	2.4	1.3	0.8	4.4	
mil	max	43	7.9	146	106	63	47	193	
	min	35	4.7	130	94	51	31	173	

**The recommended mounting pad size**



**Summary of Packing Options**

Package	Packing Description	Packing Quantity	Industry Standard
SMAF	Tape/Reel, 13" reel	10000	EIA-481-1
	Tape/Reel, 7" reel	3000	EIA-481-1