

■ NPN Transistor

■ Features

- Collector Current Capability  $I_c=50\text{mA}$
- Collector Emitter Voltage  $V_{CE0}=9\text{V}$

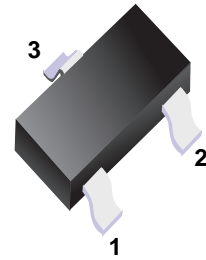

1.Base  
2.Emitter  
3.Collector

■ Simplified outline(SOT-323)

■ Absolute Maximum Ratings  $T_a = 25^\circ\text{C}$

Parameter	Symbol	Rating	Unit
Collector - Base Voltage	$V_{CBO}$	15	V
Collector - Emitter Voltage	$V_{CEO}$	9	
Emitter - Base Voltage	$V_{EBO}$	1.5	
Collector Current - Continuous	$I_c$	50	mA
Collector Power Dissipation	$P_c$	100	mW
Junction Temperature	$T_J$	150	°C
Storage Temperature Range	$T_{stg}$	-55 to 150	

■ Electrical Characteristics  $T_a = 25^\circ\text{C}$

Parameter	Symbol	Test Conditions	Min	Typ	Max	Unit
Collector- base breakdown voltage	$V_{CBO}$	$I_c = 10 \mu\text{A}, I_E = 0$	15			V
Collector-base cut-off current	$I_{CBO}$	$V_{CB} = 12 \text{V}, I_E = 0$			10	$\mu\text{A}$
Collector- emitter cut-off current	$I_{CEO}$	$V_{CE} = 9 \text{V}, I_E = \infty$			1	mA
Emitter cut-off current	$I_{EBO}$	$V_{EB} = 1.5 \text{V}, I_c = 0$			10	$\mu\text{A}$
Collector-emitter saturation voltage	$V_{CE(sat)}$	$I_c = 50 \text{mA}, I_B = 5 \text{mA}$			0.6	V
Base - emitter saturation voltage	$V_{BE(sat)}$	$I_c = 50 \text{mA}, I_B = 5 \text{mA}$			1.2	
DC current gain	$h_{FE}$	$V_{CE} = 5 \text{V}, I_c = 20 \text{mA}$	50		250	
Collector output capacitance	$C_{ob}$	$V_{CB} = 5 \text{V}, I_E = 0, f = 1 \text{MHz}$			1.4	pF
Transition frequency	$f_T$	$V_{CE} = 5 \text{V}, I_c = 20 \text{mA}$	6			GHz
Power gain	PG	$V_{CE} = 5 \text{V}, I_c = 20 \text{mA}, f = 900 \text{MHz}$	10			dB
Noise figure	NF	$V_{CE} = 5 \text{V}, I_c = 5 \text{mA}, f = 900 \text{MHz}$			2.5	

■ Classification of  $h_{fe}$

Marking	YK
---------	----

■ Typical Characteristics

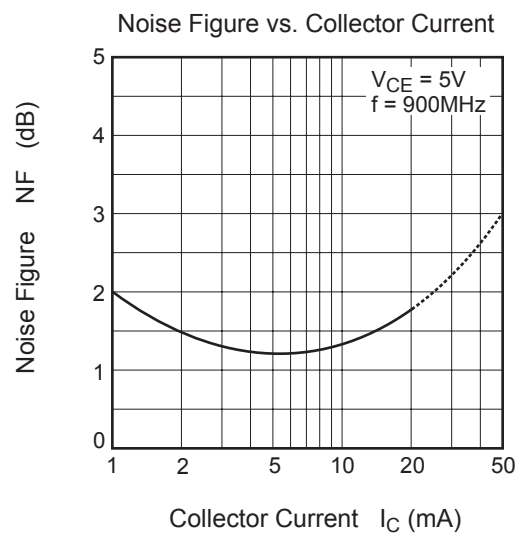
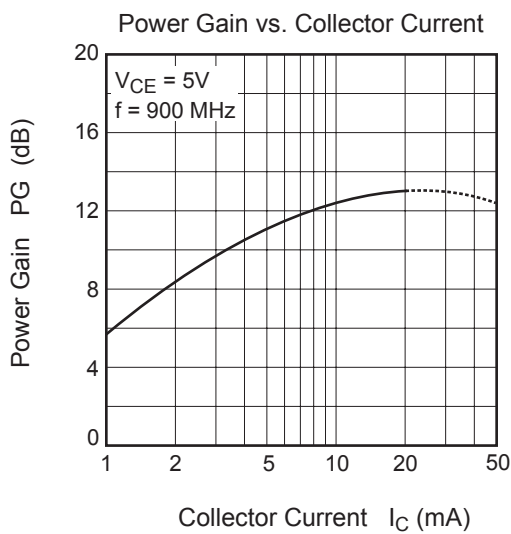
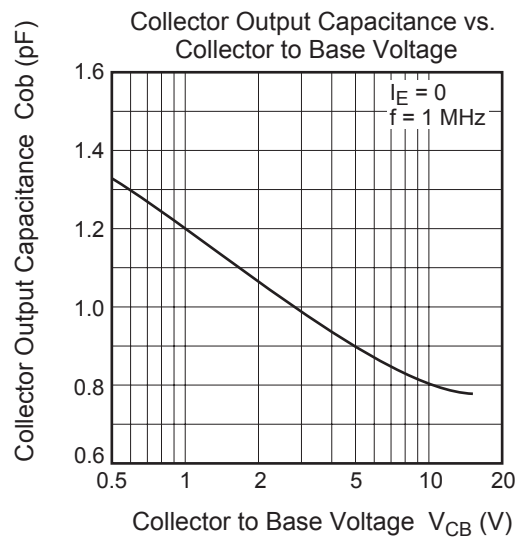
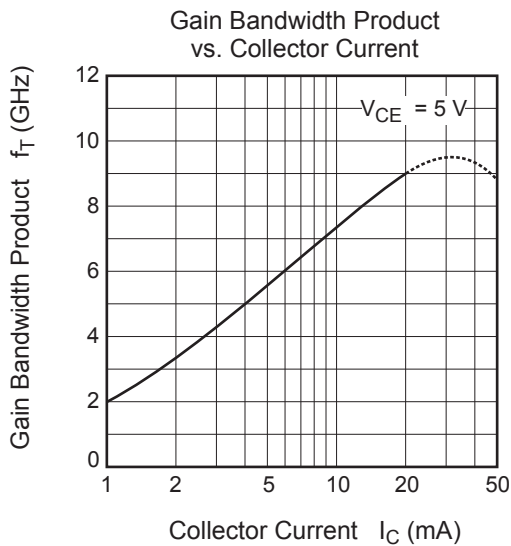
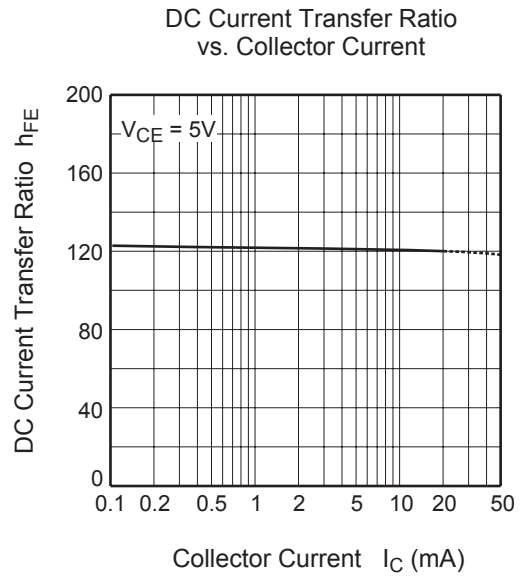
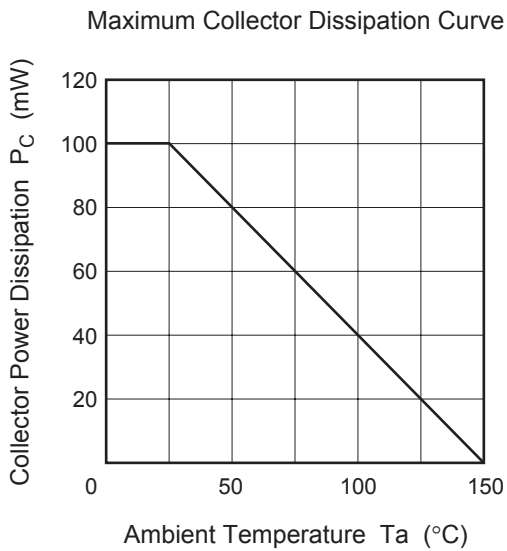

■ Typical Characteristics

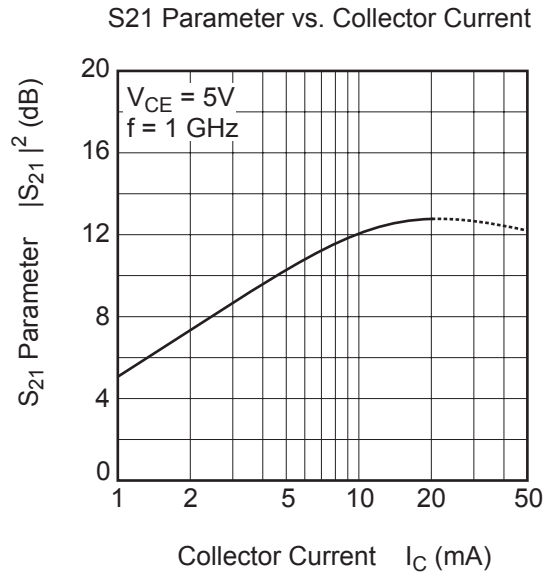

S11 Parameter vs. Frequency

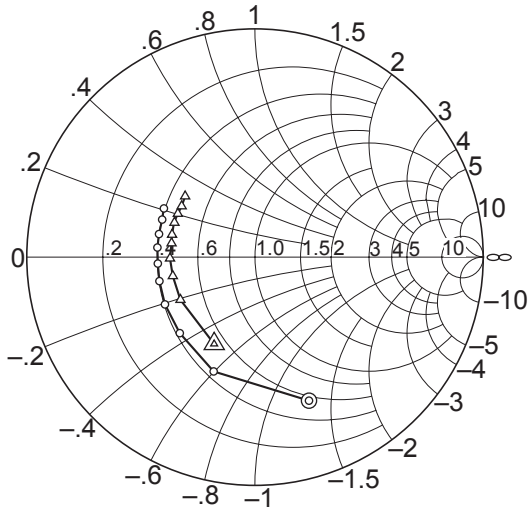

Condition:  $V_{CE} = 5\text{ V}$ ,  $Z_o = 50\ \Omega$   
200 to 2000 MHz (200 MHz step)  
 ○ — ○ ( $I_C = 5\text{ mA}$ )  
 △ — △ ( $I_C = 20\text{ mA}$ )

S21 Parameter vs. Frequency

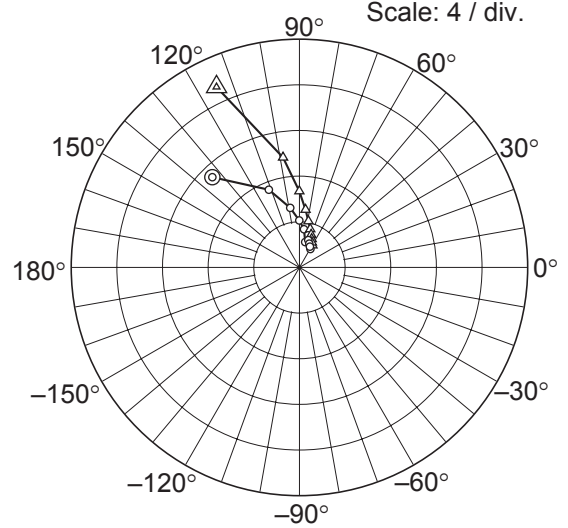

Condition:  $V_{CE} = 5\text{ V}$ ,  $Z_o = 50\ \Omega$   
200 to 2000 MHz (200 MHz step)  
 ○ — ○ ( $I_C = 5\text{ mA}$ )  
 △ — △ ( $I_C = 20\text{ mA}$ )

S12 Parameter vs. Frequency

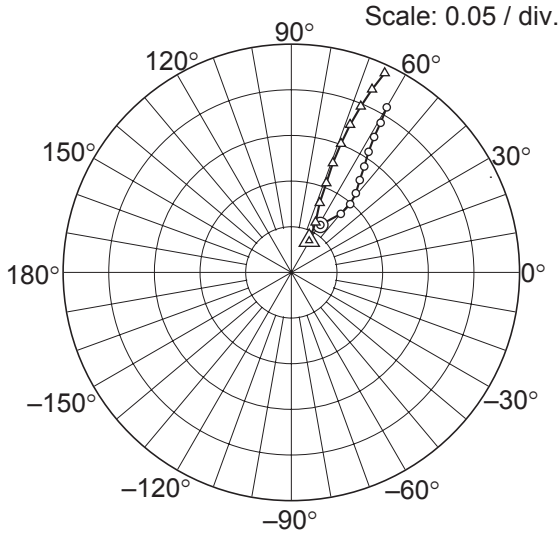

Condition:  $V_{CE} = 5\text{ V}$ ,  $Z_o = 50\ \Omega$   
200 to 2000 MHz (200 MHz step)  
 ○ — ○ ( $I_C = 5\text{ mA}$ )  
 △ — △ ( $I_C = 20\text{ mA}$ )

S22 Parameter vs. Frequency

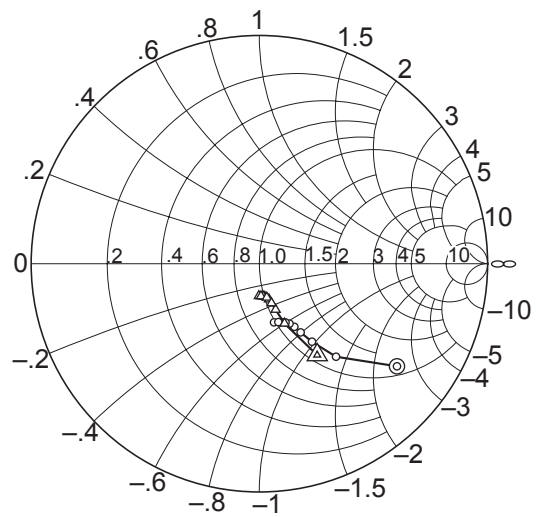

Condition:  $V_{CE} = 5\text{ V}$ ,  $Z_o = 50\ \Omega$   
200 to 2000 MHz (200 MHz step)  
 ○ — ○ ( $I_C = 5\text{ mA}$ )  
 △ — △ ( $I_C = 20\text{ mA}$ )

**S Parameter**

 ( $V_{CE} = 5\text{ V}$ ,  $I_C = 5\text{ mA}$ ,  $Z_O = 50\ \Omega$ , Emitter common)

Freq. (MHz)	S11		S21		S12		S22	
	MAG.	ANG.	MAG.	ANG.	MAG.	ANG.	MAG.	ANG.
200	0.672	-69.4	10.99	134.0	0.0610	58.8	0.752	-26.7
400	0.533	-109.9	7.32	111.5	0.0841	49.9	0.528	-50.5
600	0.469	-134.7	5.28	98.8	0.0989	49.3	0.412	-56.0
800	0.446	-152.3	4.12	90.2	0.112	50.9	0.351	-59.0
1000	0.432	-165.9	3.37	83.2	0.126	53.5	0.316	-61.0
1200	0.427	-176.2	2.88	77.2	0.141	55.5	0.294	-63.3
1400	0.430	174.1	2.52	72.1	0.157	57.4	0.282	-66.0
1600	0.433	166.5	2.26	67.5	0.174	58.6	0.274	-69.1
1800	0.439	158.0	2.04	63.3	0.191	59.2	0.269	-72.0
2000	0.453	151.9	1.88	59.2	0.209	60.0	0.265	-76.0

**S Parameter**

 ( $V_{CE} = 5\text{ V}$ ,  $I_C = 20\text{ mA}$ ,  $Z_O = 50\ \Omega$ , Emitter common)

Freq. (MHz)	S11		S21		S12		S22	
	MAG.	ANG.	MAG.	ANG.	MAG.	ANG.	MAG.	ANG.
200	0.421	-115.2	17.40	114.7	0.0399	50.6	0.474	-57.7
400	0.377	-150.2	9.74	98.5	0.0609	64.2	0.284	-67.2
600	0.370	-167.0	6.68	90.1	0.0822	67.8	0.213	-70.5
800	0.373	-179.1	5.09	84.0	0.105	68.6	0.180	-72.9
1000	0.371	170.6	4.13	79.0	0.128	69.2	0.161	-74.9
1200	0.377	164.9	3.49	74.3	0.151	68.9	0.151	-77.6
1400	0.384	156.9	3.04	70.3	0.174	68.3	0.146	-80.7
1600	0.388	150.7	2.71	66.8	0.197	67.3	0.143	-83.5
1800	0.392	145.3	2.45	63.3	0.219	66.2	0.142	-87.2
2000	0.406	139.0	2.25	59.5	0.241	64.9	0.141	-91.0

Package Outline

SOT-323

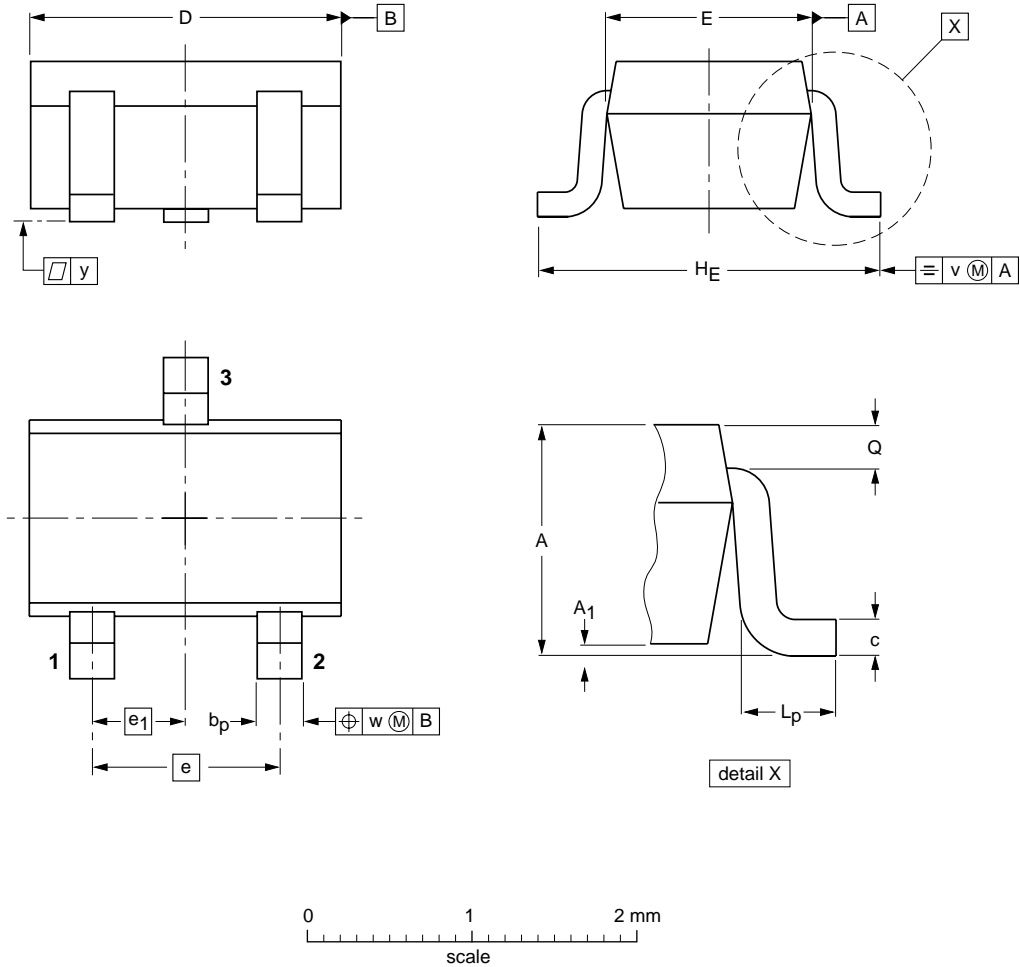

DIMENSIONS (mm are the original dimensions)

UNIT	A	A <sub>1</sub> max	b <sub>p</sub>	c	D	E	e	e <sub>1</sub>	H <sub>E</sub>	L <sub>p</sub>	Q	v	w
mm	1.1 0.8	0.1	0.4 0.3	0.25 0.10	2.2 1.8	1.35 1.15	1.3	0.65	2.2 2.0	0.45 0.15	0.23 0.13	0.2	0.2

Summary of Packing Options

Package	Package Description	Packing Quantity	Industry Standard
SOT-323	Tape/Reel, 7" reel	3000	EIA-481-1