

16A 4Quadrants TRIACs

Product Summary

Symbol	Value	Unit
$I_{T(AV)}$	16	A
$V_{DRM} V_{RRM}$	600/800	V
V_{TM}	1.5	V

Features

With high ability to withstand the shock loading of arge current, Provide high dv/dt rate with strong resistance to electromagnetic interference

Application

Power charger, T-tools, massager, solid staterelay, AC Motor speed regulation and so on.

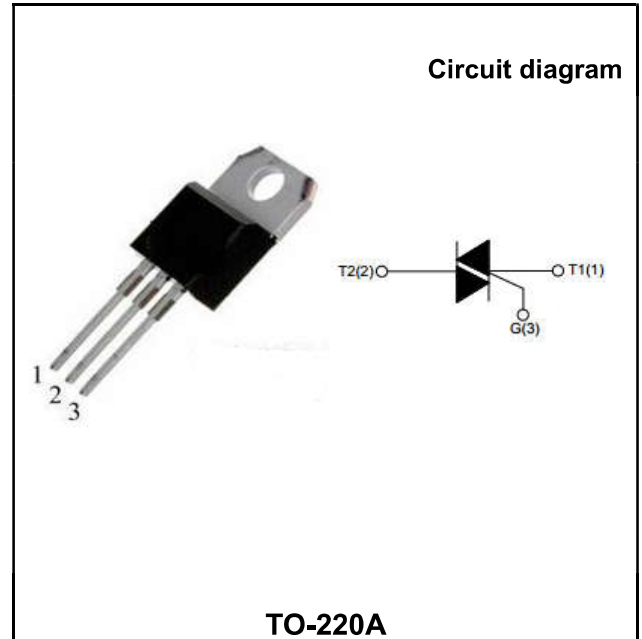

Order Information

Part Number	Package	Marking	packing	packing Quantity
BTA16	TO-220A	BTA16 XXXX	Box	1000PCS/Box

Absolute maximum ratings (Ta=25°C unless otherwise noted)

Parameter	Symbol	Value	Unit
Repetitive peak off-state voltage	V_{DRM}	600/800	V
Repetitive peak reverse voltage	V_{RRM}	600/800	V
RMS on-state current	$I_{T(RMS)}$	16	A
Non repetitive surge peak on-state current (full cycle, F=50Hz)	I_{TSM}	160	A
I^2t value for fusing (tp=10ms)	I^2t	140	A ² s
Critical rate of rise of on-state current ($I_G = 2 \times I_{GT}$)	di/dt	50	A/us
Peak gate current	I_{GM}	4	A
Average gate power dissipation	$P_G(AV)$	1	W
Junction Temperature	T_J	-40~+125	°C
Storage Temperature	T_{STG}	-40 ~+150	°C

Electrical characteristics (TA=25°C, unless otherwise noted)

Parameter	Symbol	Test Condition	Value		Unit	
			C	B		
Gate trigger current	I_{GT}	$V_D=12V, RL=33\Omega, T_j=25^\circ C, Fig.6$	I - II - III	≤ 25	≤ 50	mA
			IV	≤ 50	≤ 100	
Gate trigger voltage	V_{GT}	I - II - III - IV	≤ 1.3		V	
Gate non-trigger voltage	V_{GD}	$V_D=V_{DRM}, T_j=125^\circ C$	≥ 0.2		V	
Holding current	I_H	$I_T=500mA, Fig. 6$	≤ 25	≤ 50	mA	
Latching current	I_L	$I_G=1.2I_{GT}, Fig. 6$	I - III - IV	≤ 40	≤ 60	mA
			II	≤ 80	≤ 120	mA
Critical-rate of rise of commutation voltage	dV_D/dt	$V_D=2/3V_{DRM}, T_j=125^\circ C$	≥ 200	≥ 400	V/us	

STATIC CHARACTERISTICS

Forward "on" voltage	V_{TM}	$I_{TM}=23A, t_p=380us, Fig.4$	≤ 1.50		V	
Repetitive Peak Off-State Current	I_{DRM}	$V_D=V_{DRM} V_R=V_{RRM}$	$T_j=25^\circ C$	≤ 5	≤ 5	uA
Repetitive Peak Reverse Current	I_{RRM}		$T_j=125^\circ C$	≤ 1	≤ 1	mA

THERMAL RESISTANCES

Thermal resistance	$R_{th(j-c)}$	Junction to case	TYP.	2.1	$^\circ C/W$
	$R_{th(j-a)}$	Junction to ambient	TYP.	60	$^\circ C/W$

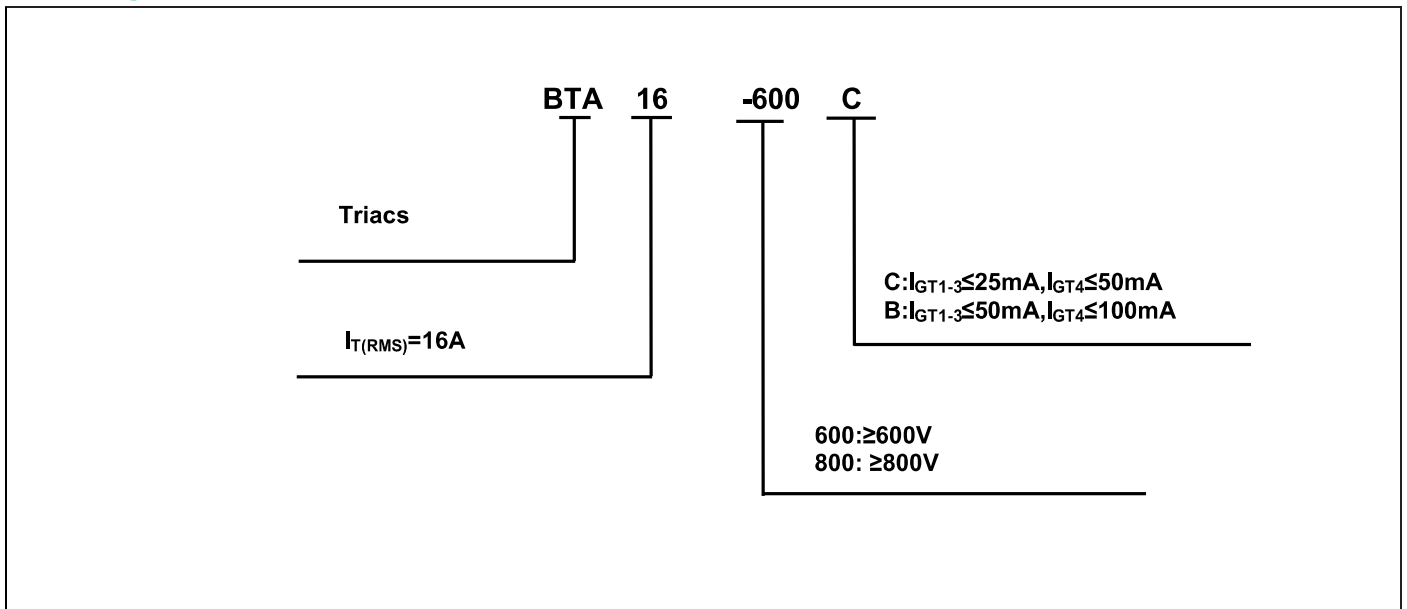
Ordering Information

Typical Characteristics

FIG1 Maximum power dissipation versus RMS on-state current

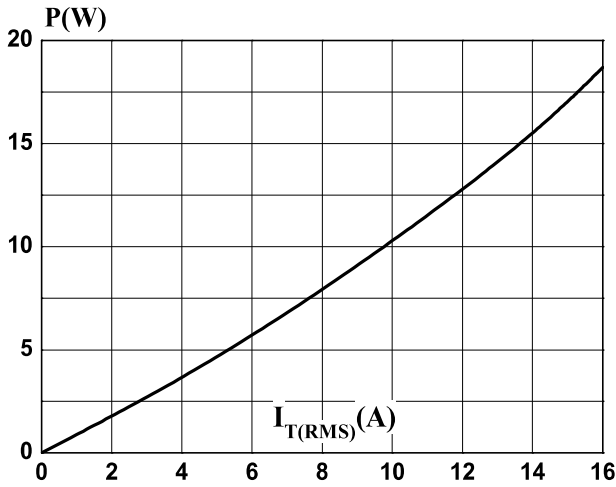

FIG2 RMS on-state current versus case temperature

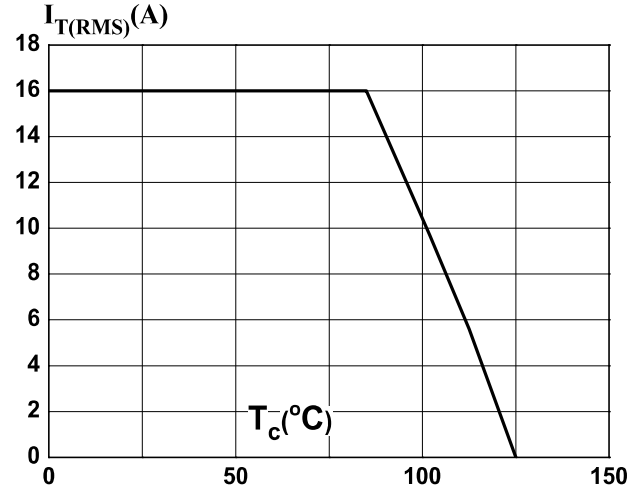

FIG3 Surge peak on-state current versus number of cycles

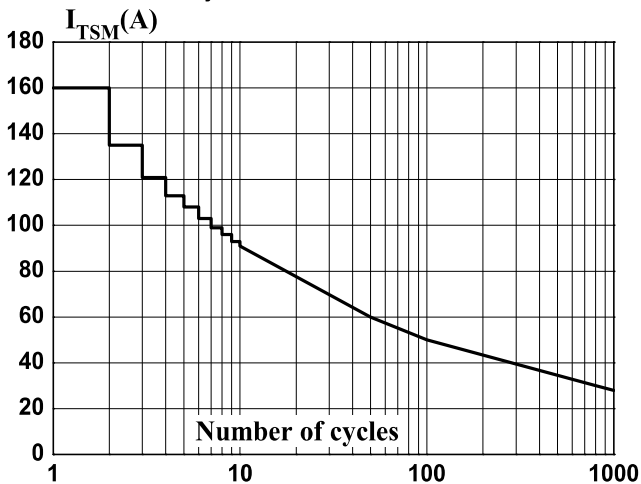

FIG4 On-state characteristics (maximum values)

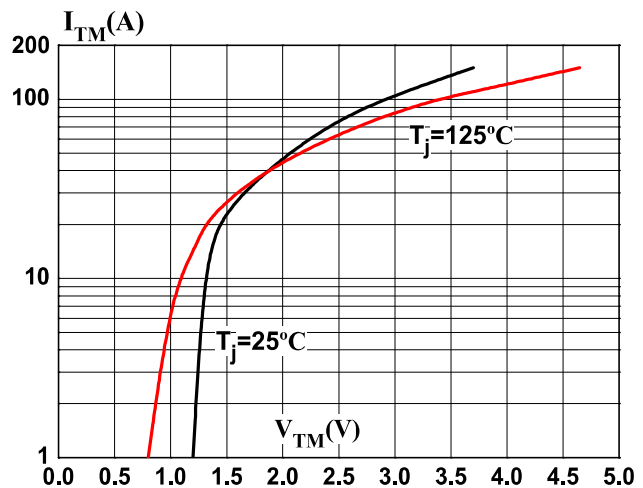

FIG5 Non-repetitive surge peak on-state current for a sinusoidal pulse with width $t_p < 20\text{ms}$, and corresponding value of I^2t ($dI/dt < 100\text{A}/\mu\text{s}$)

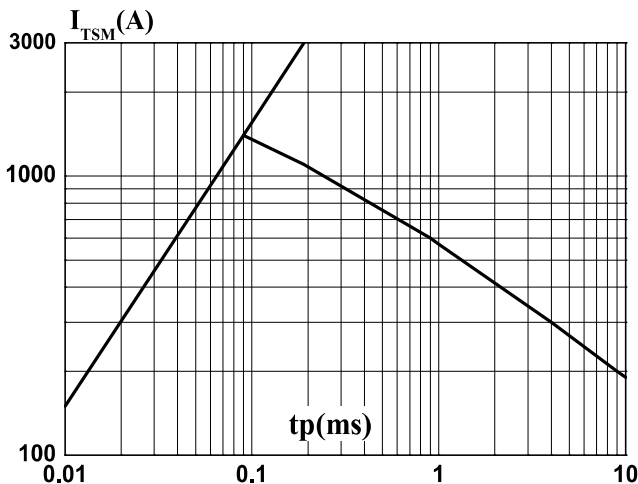
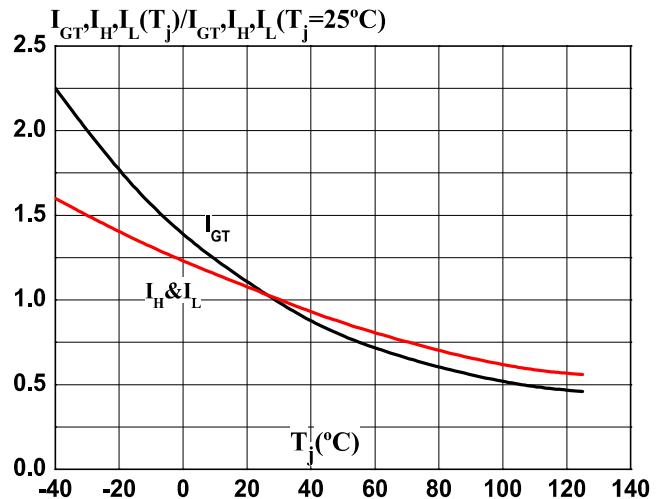
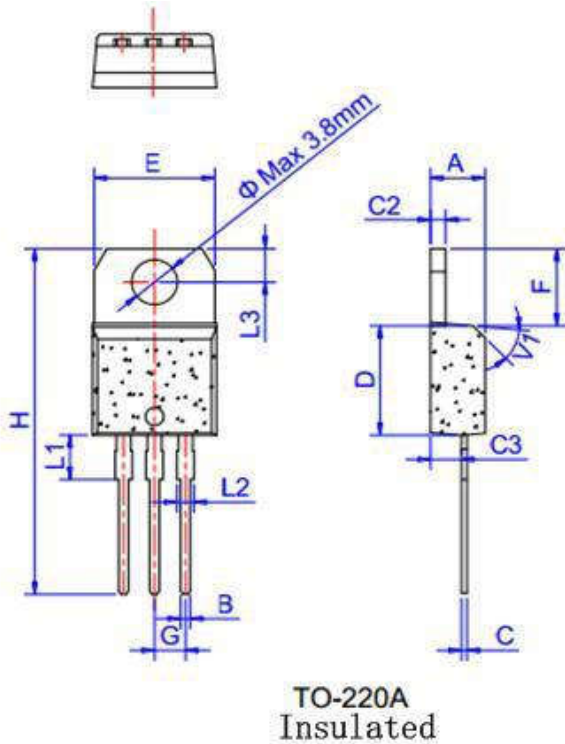

FIG6 Relative variations of gate trigger current, holding current and latching current versus junction temperature



Package Information

TO-220A(Ins)



Ref.	Dimensions					
	Millimeters			Inches		
	Min.	Typ.	Max.	Min.	Typ.	Max.
A	4.40		4.60	0.173		0.181
B	0.61		0.88	0.024		0.035
C	0.46		0.70	0.018		0.028
C2	1.21		1.32	0.048		0.052
C3	2.40		2.72	0.094		0.107
D	8.60		9.70	0.339		0.382
E	9.80		10.4	0.386		0.409
F	6.55		6.95	0.258		0.274
G		2.54			0.1	
H	28.0		29.8	1.102		1.173
L1		3.75			0.148	
L2	1.14		1.70	0.045		0.067
L3	2.65		2.95	0.104		0.116
V1		45°			45°	