

3-Terminal 1.0A Positive Voltage Regulator

Description

The 78M08AS three-terminal positive regulators are available in the TO-263 package with several fixed output voltages making it useful in a wide range of applications.

Features

- ◆ Output Current up to 1.0A
- ◆ Output Voltages of 8V
- ◆ Thermal Overload Protection
- ◆ Short Circuit Protection
- ◆ Output Transistor Safe Operating area (SOA)Protection

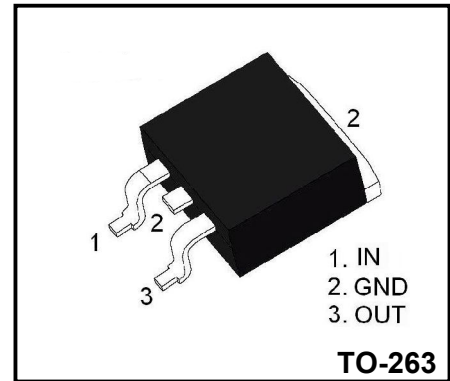

Internal Block Diagram

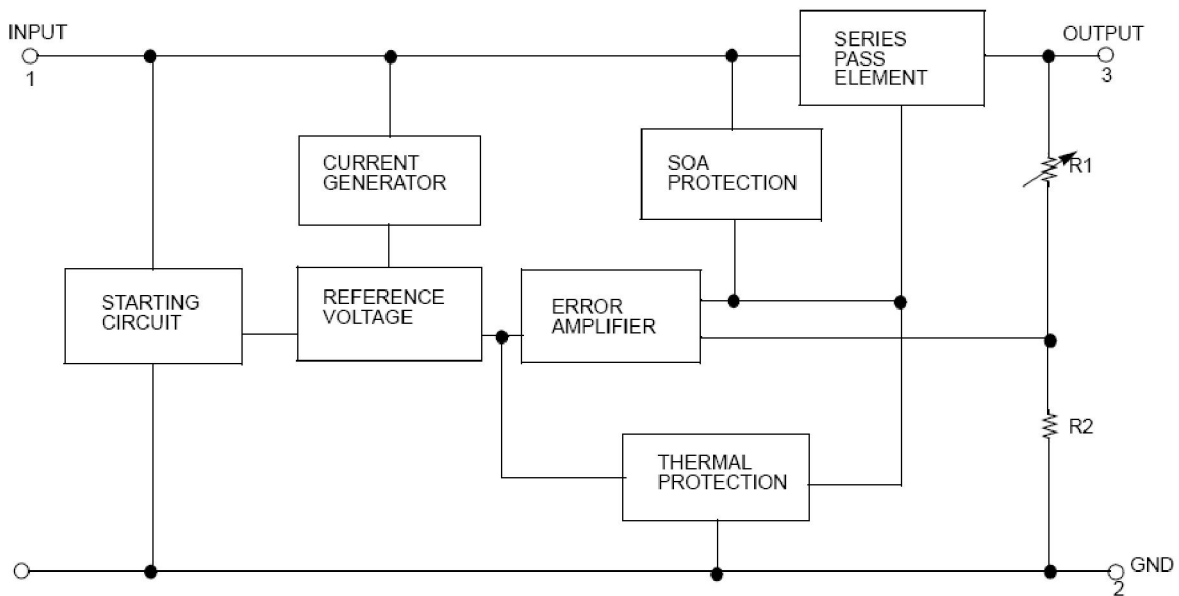

Absolute Maximum Ratings

Parameter	Symbol	Value	Unit
Input Voltage	V_{IN}	30	V
Out put Voltage	V_O	8	V
Operating Temperature Range	T_{OPR}	0 ~ + 125	°C
Storage Temperature Range	T_{STG}	-55 ~ + 150	°C

Electrical Characteristics

 (Refer to the test circuits, $I_o=500mA$, $V_i=14V$, $C_1=0.33\mu F$, $C_o=0.1\mu F$ unless otherwise specified)

Parameter	Symbol	Conditions	Value			Unit
			Min	Typ	Max	
Output Voltage	V_o	$T_J = +25^\circ C$	7.68	8.0	8.32	V
		$I_o = 5mA \sim 1A$ $V_i = 10.5 \sim 23V$	7.6	8.0	8.4	
Line Regulation(Note)	ΔV_o	$T_J = 25^\circ C$	$V_i = 10.5V \sim 25V$		160	mV
			$V_i = 11.5V \sim 17V$		80	
Load Regulation(Note)	ΔV_o	$T_J = 25^\circ C$	$I_o = 5mA \sim 1.0A$		200	mV
			$I_o = 250mA \sim 750mA$		100	
Quiescent Current	I_Q	$T_J = 25^\circ C$			8.0	mA
Quiescent Current Change	ΔI_Q	$I_o = 5mA \sim 1.0A$			0.5	mA
		$V_i = 10.5 \sim 25V$			1.0	
Output Voltage Drift	$\Delta V / \Delta T$	$I_o = 5mA$		-0.8		mV/ $^\circ C$
Output Noise Voltage	V_N	$f = 10HZ \sim 100KHZ$		52		μV
Ripple Rejection	RR	$f = 120Hz$, $V_i = 11.5 \sim 21.5V$		80		dB
Dropout Voltage	V_D	$I_o = 1A$, $T_J = 25^\circ C$		2		V
Short Circuit Current	I_{SC}	$V_i = 35V$, $T_J = 25^\circ C$		230		mA
Peak Current	I_{PK}	$T_J = 25^\circ C$		1.6		A

Notes:

 Load and line regulation are specified at constant junction temperature. Change in V_o due to heating effects must be taken into account separately. Pulse testing with low duty is used.

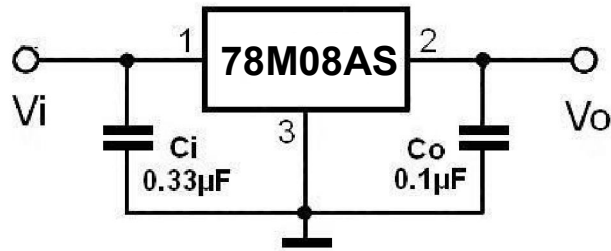

Figure.1 DC Parameter

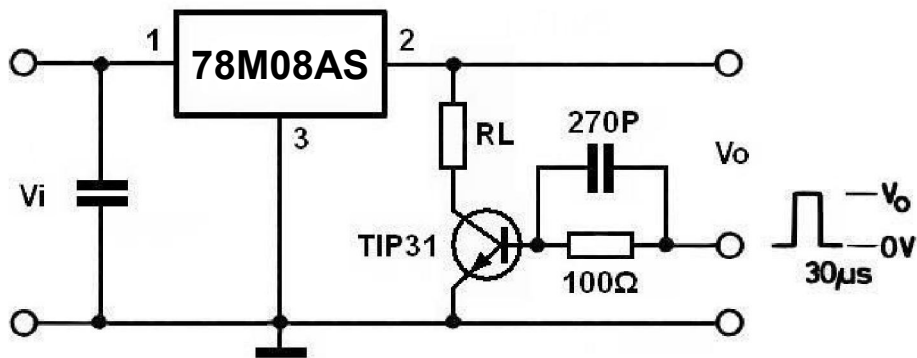

Figure.2 Load Regulation

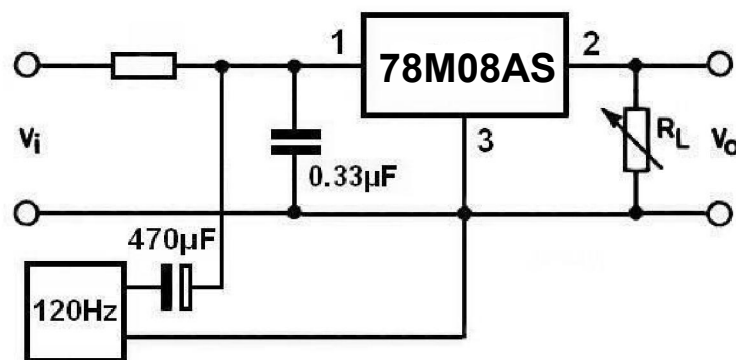

Figure.3 Ripple Rejection

Typical Characteristics

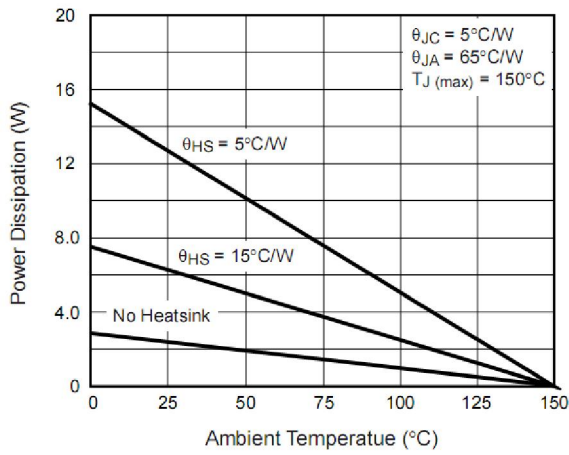

Figure. 4 Power Dissipation vs. Ambient Temperature

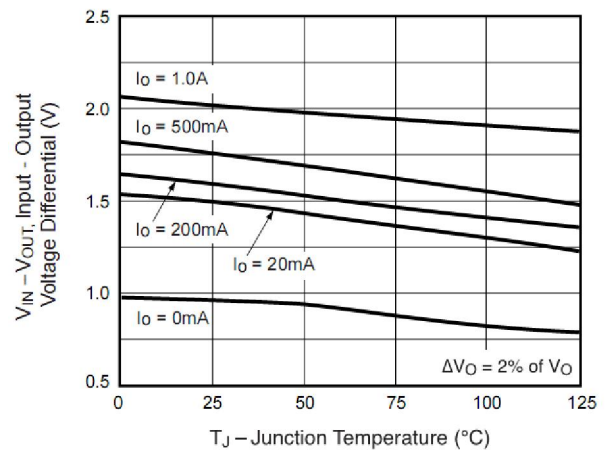

Figure.5 Dropout Voltage vs. Junction Temperature

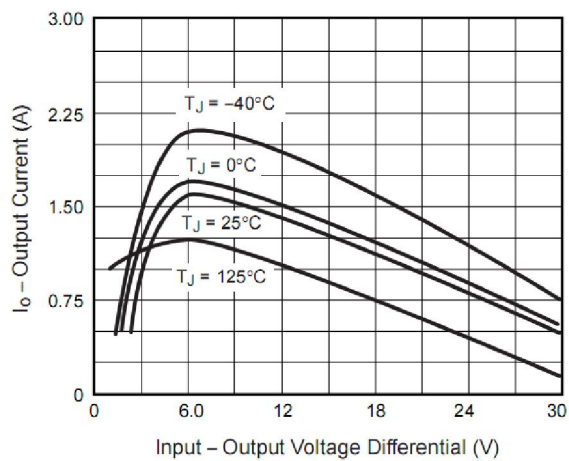

Figure.6 Peak Output Current

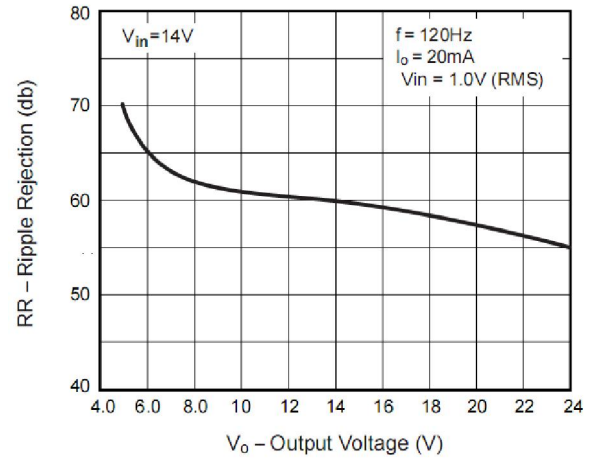

Figure.7 Ripple Rejection Ratio vs. Output Voltage

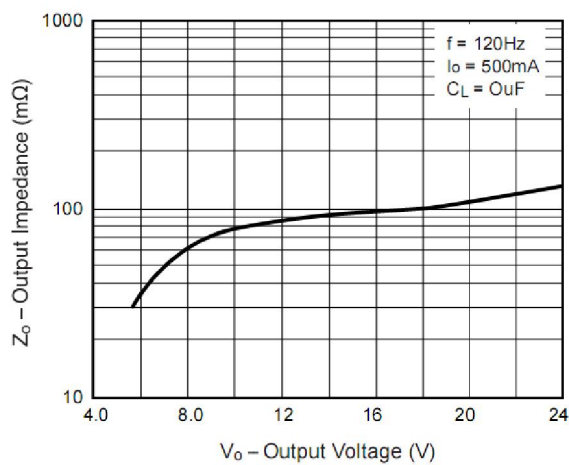

Figure.8 Output Impedance (mΩ) vs. Output Voltage

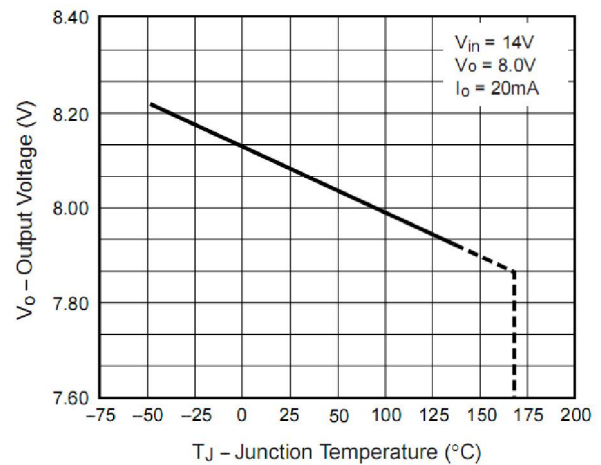

Figure.9 Output Voltage vs. Junction Temperature

Typical Characteristics

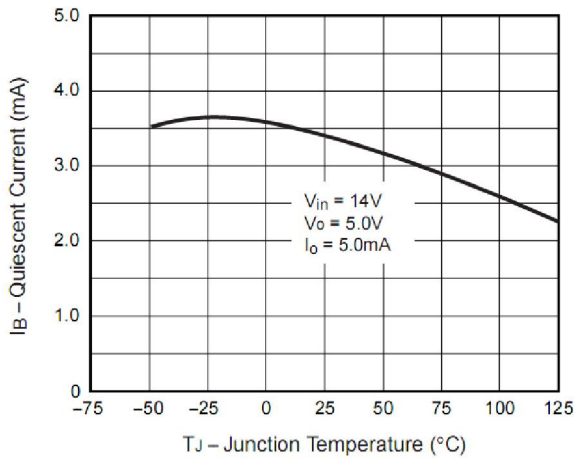

Figure.10 Quiescent Current vs. Junction Temperature

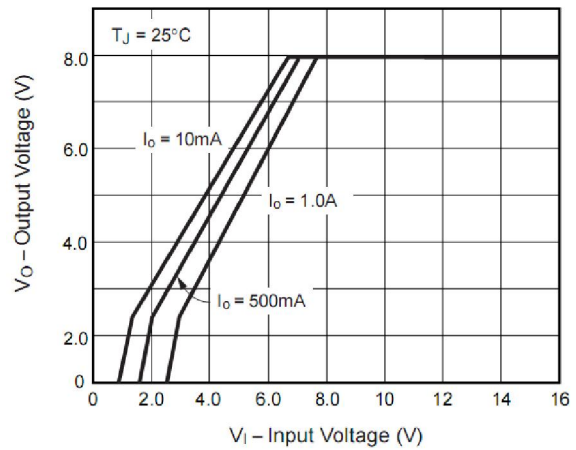

Figure.11 Output Voltage vs. Input Voltage

Package Dimensions TO-263

Dim	Millimeter		Inches	
	Min.	Max.	Min.	Max.
A	4.30	4.70	0.169	0.185
A1	0.00	0.15	0.000	0.006
A2	4.30	4.55	0.169	0.179
B	1.10	1.50	0.043	0.059
b	0.70	0.90	0.028	0.035
b1	1.20	1.50	0.047	0.059
c	0.30	0.60	0.012	0.024
c1	1.17	1.37	0.046	0.054
D	9.90	10.20	0.390	0.402
E	8.50	8.90	0.335	0.350
e	2.44	2.64	0.096	0.104
e1	4.88	5.28	0.192	0.208
L	15.00	15.30	0.591	0.602
L1	5.20	5.40	0.205	0.213
L2	2.40	2.60	0.094	0.102
L3	1.60	1.80	0.063	0.071

Product Specification Classification

Part Number	Package	Marking	Pack
78M08AS	TO-263	78M08AS XXXXX	800PCS/Reel