

**VOLTAGE RANGE: 50 - 1000V**  
**CURRENT: 1.0 A**

### Features

- Glass Passivated Die Construction
- Diffused Junction
- Ultra-Fast Recovery Time for High Efficiency
- Low Forward Voltage Drop, High Current Capability, and Low Power Loss
- Ideally Suited for Automated Assembly
- Plastic Material: UL Flammability Classification Rating 94V-0

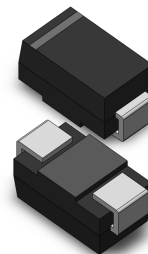

### Mechanical Data

- Case: SMA/DO-214AC, Molded Plastic
- Terminals: Solder Plated, Solderable per MIL-STD-750, Method 2026
- Polarity: Cathode Band or Cathode Notch
- Marking: Type Number
- Weight: 0.064 grams (approx.)

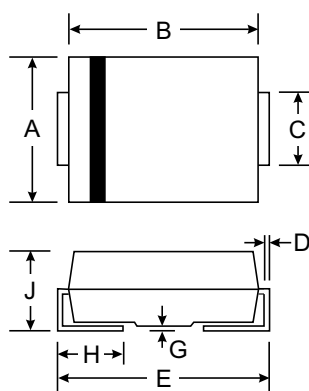

SMA(DO-214AC)		
Dim	Min	Max
A	2.29	2.92
B	4.00	4.60
C	1.27	1.63
D	0.15	0.31
E	4.80	5.59
G	0.10	0.20
H	0.76	1.52
J	2.01	2.62
All Dimensions in mm		

### Maximum Ratings and Electrical Characteristics $T_A = 25^\circ\text{C}$ unless otherwise specified

Single phase, half wave, 60Hz, resistive or inductive load. For capacitive load, derate current by 20%.

Characteristic	Symbol	UF1A	UF1B	UF1D	UF1G	UF1J	UF1K	UF1M	Unit
Maximum repetitive peak reverse voltage	$V_{RRM}$	50	100	200	400	600	800	1000	V
Maximum RMS voltage	$V_{RMS}$	35	70	140	280	420	560	700	V
Maximum DC blocking voltage	$V_{DC}$	50	100	200	400	600	800	1000	V
Maximum average forward rectified current at $T_A=65^\circ\text{C}$ (NOTE 1)	$I_{(AV)}$	1.0							A
Peak forward surge current 8.3ms single half sine-wave superimposed on rated load (JEDEC Method) $T_L=25^\circ\text{C}$	$I_{FSM}$	25.0							A
Maximum instantaneous forward voltage at 1.0A	$V_F$		1.0		1.4		1.7		V
Maximum DC reverse current at rated DC blocking voltage $T_A=25^\circ\text{C}$ / $T_A=125^\circ\text{C}$	$I_R$	5.0 / 100.0							$\mu\text{A}$
Maximum reverse recovery time (NOTE 2)	$t_{rr}$		50				75		ns
Typical thermal resistance (NOTE 4)	$R_{\theta JA}$	180							K/W
Operating junction and storage temperature range	$T_J, T_{STG}$	-50 to +150							$^\circ\text{C}$

- Note:**
1. Averaged over any 20ms period.
  2. Measured with  $I_F=0.5\text{A}$ ,  $I_R=1\text{A}$ ,  $I_{rr}=0.25\text{A}$ .
  3. Measured at 1MHz and applied reverse voltage of 4.0V D.C.
  4. Thermal resistance junction to ambient, 6.0 mm<sup>2</sup> copper pads to each terminal.

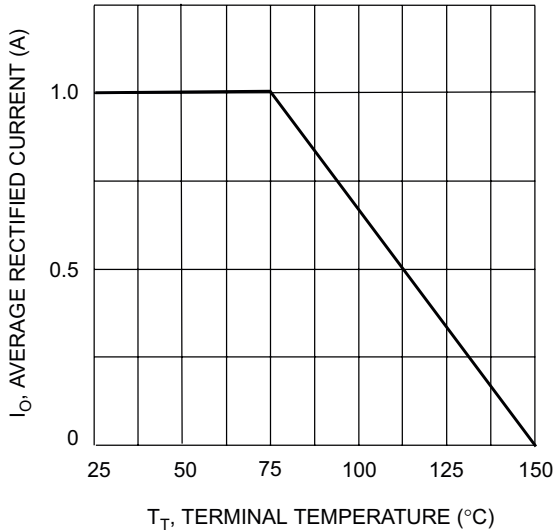

Fig. 1 Forward Current Derating Curve

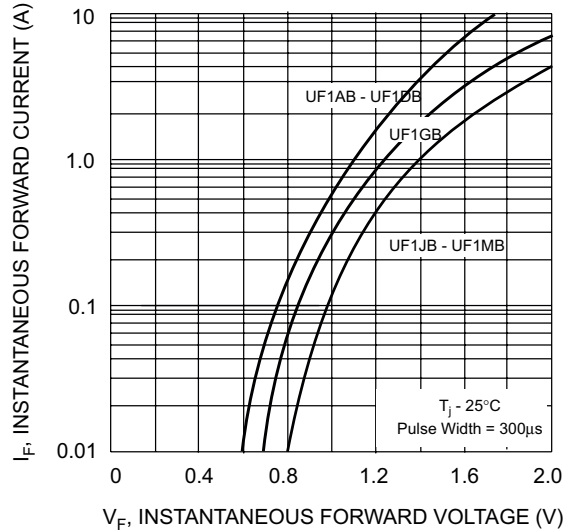

Fig. 2 Typical Forward Characteristics

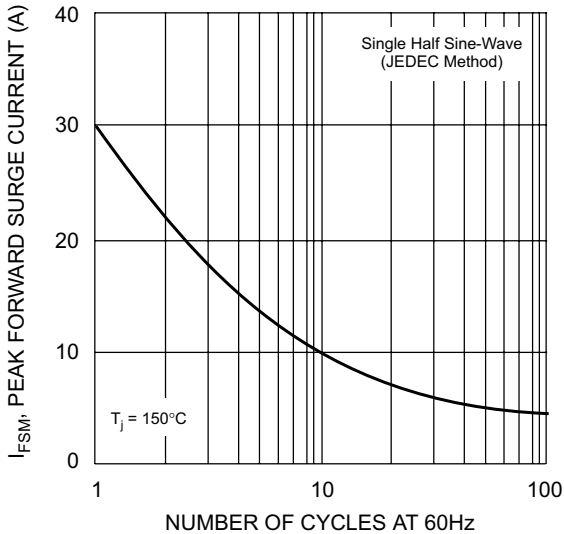

Fig. 3 Forward Surge Current Derating Curve

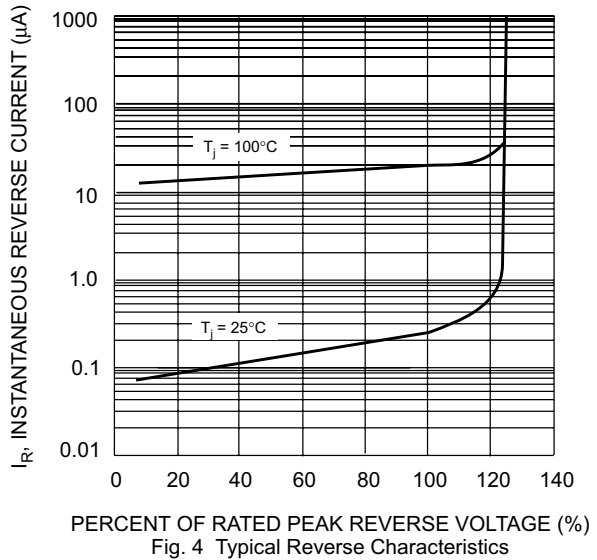
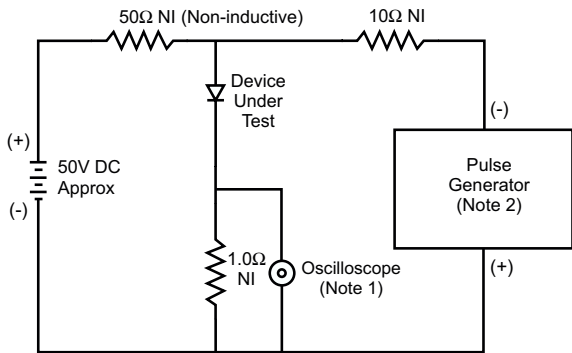
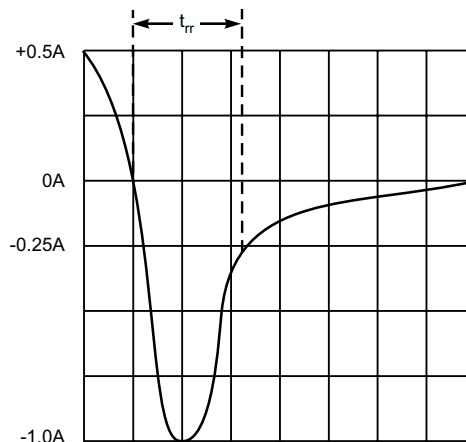

Fig. 4 Typical Reverse Characteristics



Notes:

1. Rise Time = 7.0ns max. Input Impedance = 1.0M $\Omega$ , 22pF.
2. Rise Time = 10ns max. Input Impedance = 50 $\Omega$ .



Set time base for 50/100 ns/cm

Fig. 5 Reverse Recovery Time Characteristic and Test Circuit