

CRYSTAL SPECIFICATION



Customer : _____
Customer P/N : _____
Agent : _____
Agent Code : _____
SIWARD P/N : XTL5A1100-M118-056

Customer Approval :

希華晶體科技股份有限公司
SIWARD CRYSTAL TECHNOLOGY CO., LTD.

業務部/ SALE DEPARTMENT
TEL: (04)25347909
FAX: (04)25327885 / 25337396
URL HTTP://www.siward.com.tw

DATE : 2014/06/16

Approved By : Steve Chen

品質保證部/ QUALITY ASSURANCE DEPT.
TEL: (04)25347909 EXT 1340/1341

Checked By : Tom Tang

研發部/R & D DEPT.
TEL: (04)25347909 EXT 1521

Designer : Sally Lin

Address: 1-1, LANE 111, JUNG-SHAN RD., SEC.3, TANTZU HSING, TAICHUNG 427, TAIWAN, R.O.C.

Rev.	Description of Revision History	Date	Designer	Checked By
1	New Publication	2014/06/16	Sally Lin	Tom Tang

CRYSTAL SPECIFICATION

- 1. Description : Quartz Crystal
 - 2. Nominal Frequency : 26.000000 MHz
 - 3. Center Frequency : 26.000000 MHz
 - 4. Dimension & Drawing No. : SXT-2520 ; SXD-00311
 - 5. Oscillation Mode : Fundamental
 - 6. Cutting Mode : AT cut
 - 7. Packing Style : TP-159
 - 8. Measurement Instrument : S&A 250B(Measured FL)
 - 9. Electrical Characteristics :
- [1] Operating Conditions :

Item	Symbol	MIN.	TYP.	MAX.	Unit	Condition
Operating Temperature Range	Topt	-30		85	°C	
Storage Temperature Range	Tstg	-40		85	°C	
Load Capacitance	CL		7		pF	
Drive Level	DL			100	μW	

[2] Frequency Stability :

Item	Symbol	MIN.	TYP.	MAX.	Unit	Condition
Tolerance	dF/Fo	-10		10	ppm	Refer to Center Frequency @25±3°C @Offset +10ppm
Stability Over Temperature(1)	dF/F25	-10		10	ppm	@-25°C~85°C
Nonlinearity	dF/F25	-0.5		0.5	ppm	Freq. perturbation over operation temp. / step:2°C . (Temp. curve fit 3rd order)
Trim Sensitivity Over Load	TS	25.2	28	30.8	ppm/pF	@CL
Aging	dF/F30	-1		1	ppm	+/-1ppm@1Yr ; +/-1.5ppm@2Yrs ; +/-2.5ppm@5Yrs ; +/-5ppm@10Yrs

dF/Fo: Frequency Deviation Refer to Center Frequency

dF/F25: Frequency Deviation Refer to 25 °C Frequency

[3] Electrical Performance :

Item	Symbol	MIN.	TYP.	MAX.	Unit	Condition
Equivalent Series Resistance	ESR			30	Ω	@Series
Shunt Capacitance	C0			5	pF	
SPUR	SPUR	500			Ω	@Fo+/-1MHz
Insulation Resistance	IR	500			MΩ	@DC 100 Volt
FDDL	dF/F25			2	ppm	@0.01~100μW / Step:10
DLD2	ΔR			2.5	Ω	@0.01~100μW / Step:10
FDLDH	dF/F25			0.7	ppm	@0.01~100μW / Step:10
DLDH2	ΔR			1.5	Ω	@0.01~100μW / Step:10

10. Marking : Laser

<p>*Y->Last 1 digit of the year *WW->Week of the year *Z -> Lot *## -> Option Code(Alphabet & Number 2 digits or blank.) (For T-Sensor)</p>	<div style="border: 1px solid black; padding: 10px; width: fit-content; margin: auto;"> <p>26000## ○ SYWWZ</p> </div>
--	---

11. Remark :

<p>* Compliant with RoHS and Siward QAD-S-116 Standard.</p>

■Note

1.General cleaning solutions or ultrasonic cleaning method may be used to clean our products. However, under certain circumstances, ultrasonic cleaning machine could generate resonance at the oscillation frequency of our products and thus deteriorate the electrical characteristics in devices, and even damage the overall structure of devices. Therefore, verification test is recommended before cleaning.

2.Avoid mounting and processing by Ultrasonic welding this method has a possibility of an excessive vibration spreading inside the crystal products and becoming the cause of characteristic deterioration and not oscillating.

■ Hysteresis Specifications

Item	Min	Nom	Max	Units	Notes
Full cycle temperature hysteresis	-0.5		+0.5	ppm	Difference in freq. measurement at any temperature when undergoing a thermal cycle over the entire operation temperature range from -40°C to 85°C for per 2 degree test.
Small cycle temperature hysteresis	-0.05		+0.05	ppm	Difference in freq. measurement at any temperature when undergoing a thermal cycle of a temperature range of 5°C for per 1 degree test.

■ Curve Fitting Parameters Specifications

S curve (fL) 3rd order curve fitting coefficient requirement over operation temperature under per 2 °C test. [f (T) = C3*(T-T0)^3 + C2*(T-T0)^2 + C1*(T-T0) + C0 ; T0 = 25 °C]

Item	Min	Nom	Max	Units	Notes
C1	-0.35	-0.225	-0.1	ppm/°C	
C2	-12	-8.5	-5	10 ⁻⁴ ppm/°C ²	
C3	8.7	9.9	11	10 ⁻⁵ ppm/°C ³	

■ Freq. slope Specifications

Freq. slope error between measured S curve (fL) data and 3rd order curve fitting data over operation temperature under per 2 °C test.

Item	Min	Nom	Max	Units	Notes
Slope1	-0.05		0.05	ppm	@ -10°C ~60°C
Slope2	-0.1		0.1	ppm	@ -30°C ~85°C

■ G sensitivity Specifications

Item	Min	Nom	Max	Units	Notes
G sensitivity			2	ppb/G	Gamma vector of all three axes from 30Hz to 1.5KHz.

■ Thermistor Specifications

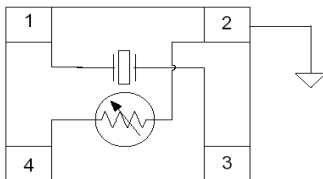

Size: 0201

Item	MIN.	TYP.	MAX.	Unit	Condition
Resistance		100		kΩ	25°C
B-constant		4250		K	25-50°C
Tolerance	-1.0		+1.0	%	

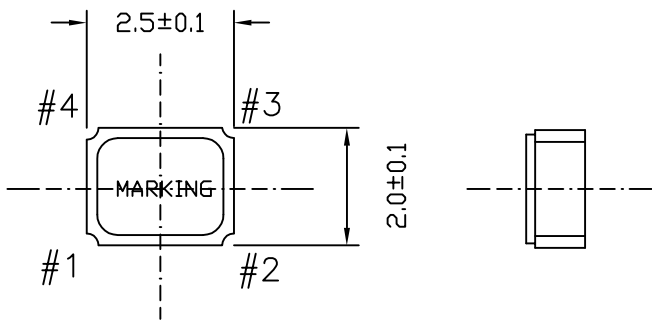

PIN NO.	PIN LAYOUT
#1	Crystal
#2	GND
#3	Crystal
#4	SENSOR

TOP VIEW

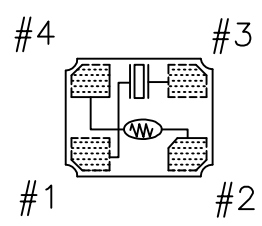
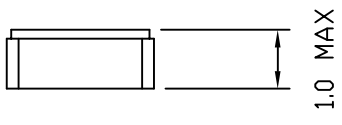

LAND PATTERN (REFERENCE)

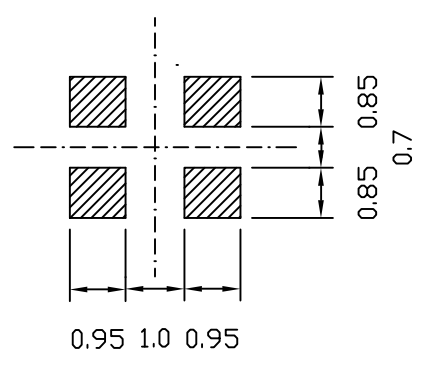
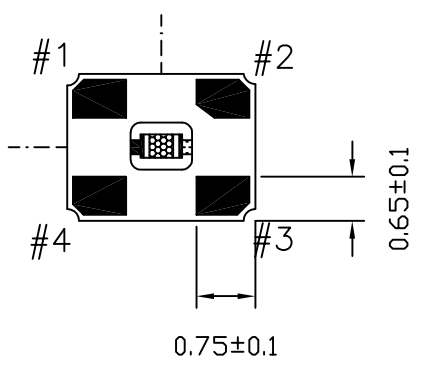

			DRAWING NAME	SXT-2520		
			DRAWING NO.	SXD-00311		
1	NEW EDITION	11.05.20	SCALE		UNIT	mm
NO.	MODIFY CONTENTS	DATE	APPROVE	<i>Jason</i>	DESIGNER	<i>Edward</i>

1. CARRIER TYPE

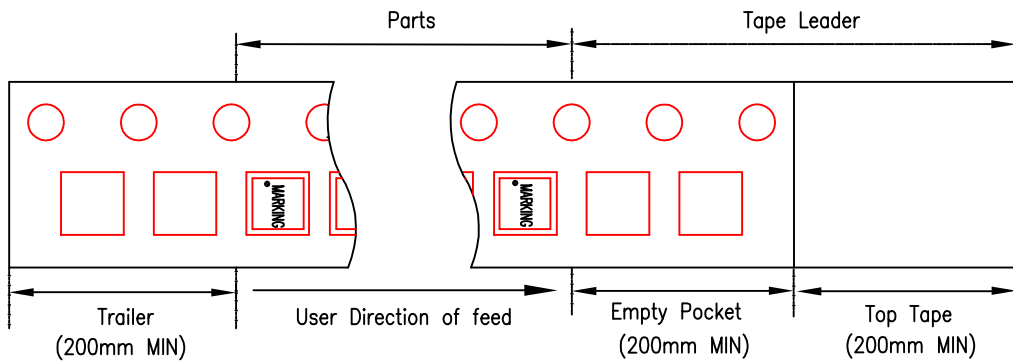
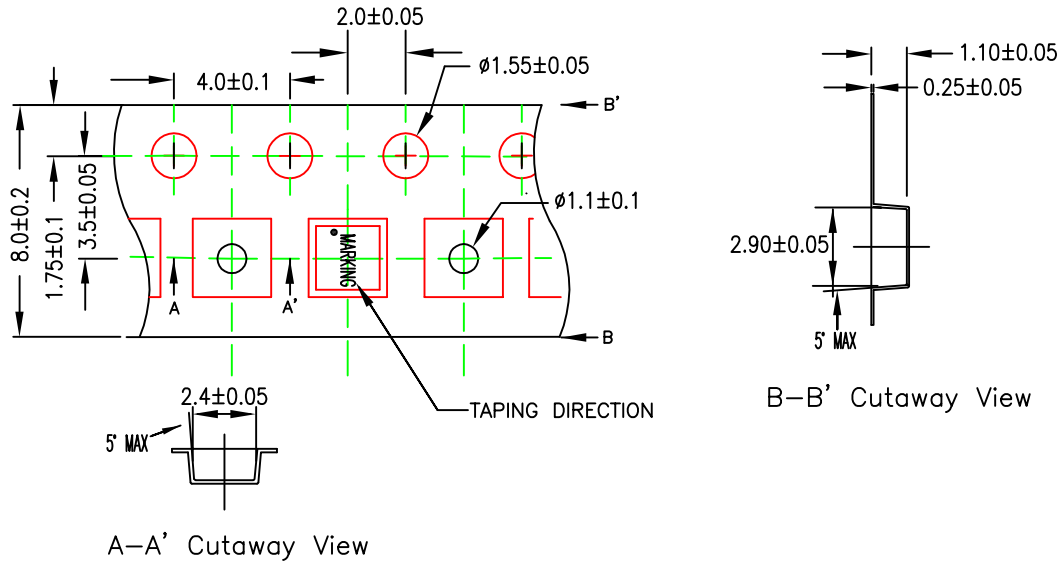

2. REEL : 3000PCS

C. ENLARGE

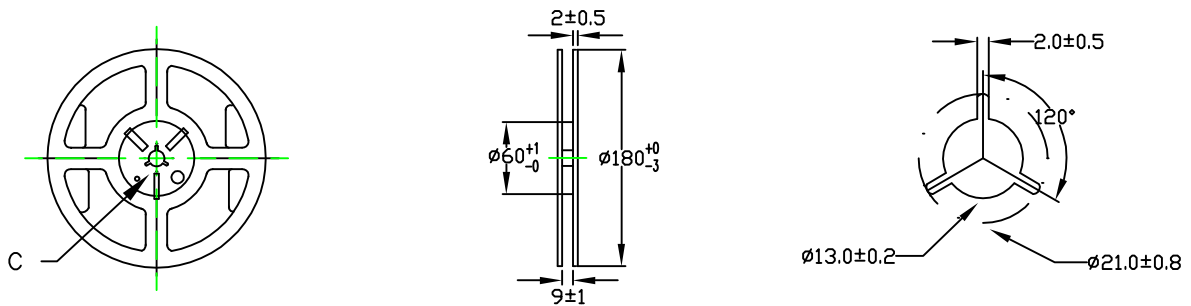

			DRAWING NAME	SXT-2520 REEL PACKING		
			DRAWING NO.	TP-159		
1	NEW EDITION	11.05.31	SCALE		UNIT	mm
NO.	MODIFY CONTENTS	DATE	APPROVE	<i>Jason</i>	DESIGNER	<i>John</i>