

VOLTAGE RANGE: 200 - 1000V

CURRENT: 8.0A

Features

- Glass passivated chip junctions
- High Speed recovery time for switching mode application
- High Forward Surge Capability
- Low Reverse Current
- Lead free in compliance with EU RoHS 2011/65/EU directive

Mechanical Data

- Circuit figure: Single positive
- Leads: Solderable per mil-std-202, Method 208
- Polarity: as marked
- Mounting torque: 5 in-lbs maximum
- Terminals: Puretin plated
- Weight: TO-220AC 1.80 grams

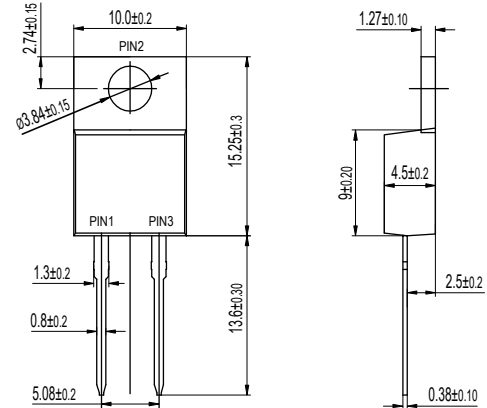
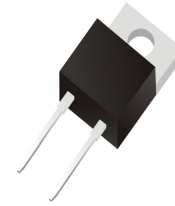

TO-220AC

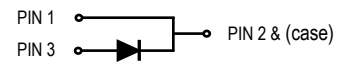

Maximum Ratings And Electrical Characteristics $T_A = 25^\circ\text{C}$

RATINGS	SYMBOL	MUR 820	MUR 830	MUR 840	MUR 860	MUR 880	MUR 8100	UNIT
Maximum repetitive reverse voltage	VRRM	200	300	400	600	800	1000	V
Maximum RMS voltage	VRMS	140	210	280	420	560	700	V
Maximum DC blocking voltage	VDC	200	300	400	600	800	1000	V
Maximum average forward current	I _{AV}	8						A
Peak forward surge current, 8.3ms single half sine-wave superimposed on rated load	I _{FSM}	125						A
Typical thermal resistance per diode (Note 1)	R _{θ-JC}	2.5						°C/W
Operating junction temperature range	T _J	-55 to +150						°C
Storage temperature range	T _{STG}	-55 to +150						°C
Maximum forward voltage per leg at 8A	V _F	1.00	1.30		1.70			V
Maximum average reverse current at rated DC blocking voltage T _J =25°C T _J =125°C	I _R	5 250						μA
Maximum reverse recovery time (Note 2)	T _{RR}	50				100		nS

Notes: 1. Thermal resistance from junction to case.
2. Test conditions: I_F=0.5A, I_R=1.0A, I_{RR}=0.25A.

FIG. 1 - TYPICAL FORWARD CURRENT DERATING CURVE

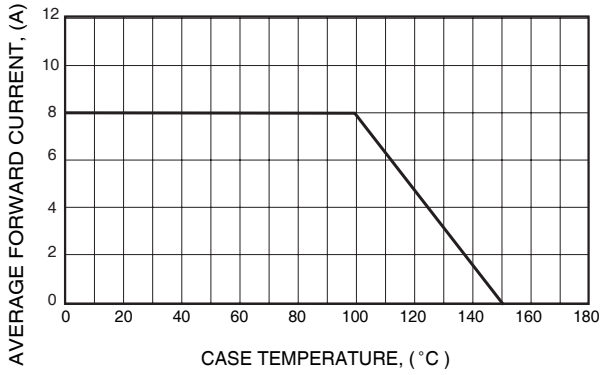

FIG. 3 - MAXIMUM NON-REPETITIVE FORWARD SURGE CURRENT

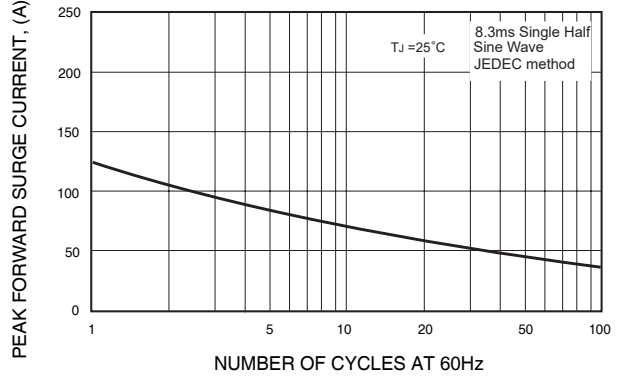

FIG. 4 - TYPICAL REVERSE CHARACTERISTICS

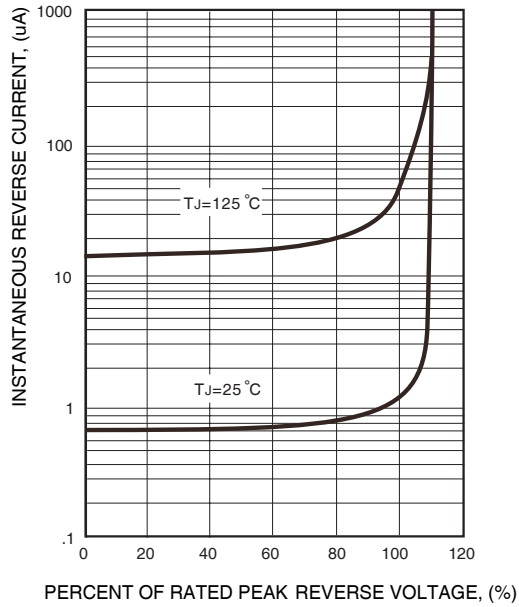

FIG. 2 - TYPICAL INSTANTANEOUS FORWARD CHARACTERISTICS

